





# Corvette

Dealer Order Guide inserts are your first look at Chevrolet Passenger Car models for 1998. Overall improvements, changes and deletions are highlighted. Use these inserts to assist you in ordering your initial shipments. Note: This information is preliminary and is subject to change.

**FOCUS: Corvette coupe**

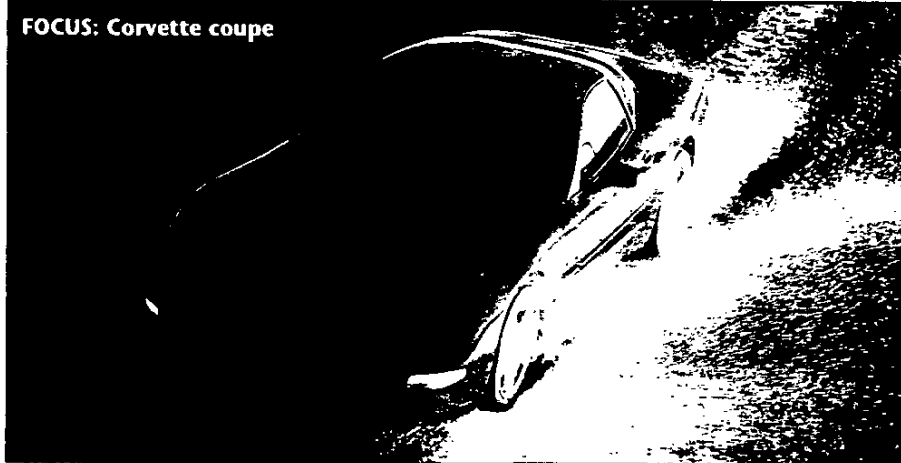

**FOCUS: Corvette coupe**

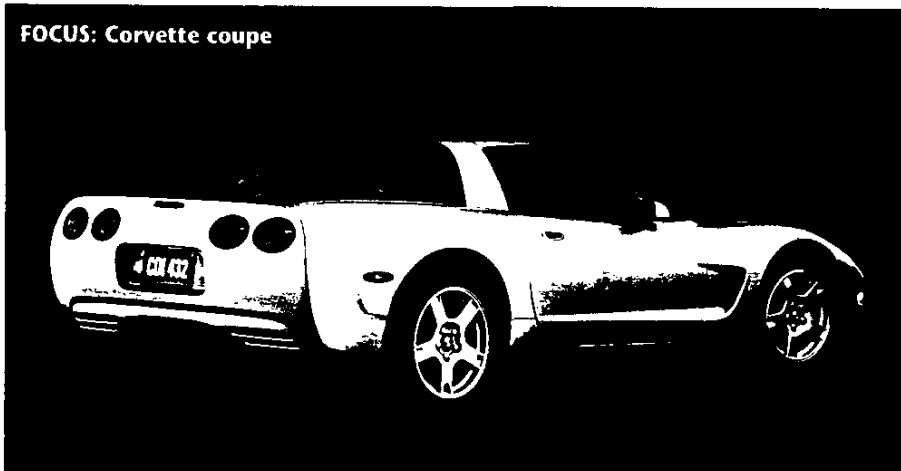

**Corvette at a glance**

*The fifth-generation Corvette is designed to meet the demands of today's driving enthusiast. New for 1998 is the stunning Corvette convertible with an easy-folding top and integral trunk.*

*For 1998, Corvette remains a showcase of power, image and value.*

Corvette



### Corvette coupe (images above)

The Focus vehicle is the model chosen for its saleability. It is equipped with the product features that customers want most. Generally, it is the "volume" vehicle that comprises the majority of the build. You'll want to be sure you have several of these models in stock. NOTE: Model, PEG and optional equipment may vary in your locality. Use the Retail Sales Analyst's (RSA) to verify or select your dealership's Focus vehicle content.

The Focus vehicle for 1998 is Corvette coupe. Introduced in January as a 1997 model and the first all-new Corvette since 1984, this fifth-generation Corvette returns for 1998 with even more appeal. This model represents the best opportunity for high-volume Corvette sales at your dealership.

**Ordering Recommendations:**  
Recommended Corvette coupe content, based on anticipated national sales volume, is listed below to assist your dealership in ordering.

See page 4 for additional standard feature details.

#### Suggested Individual Options:

- Transparent Removable Roof Panel
- Electric Dual-Zone Air Conditioning
- Memory Package
- 6-Speed Manual Transmission
- Foglamps
- 6-Way Adjustable Power Passenger Seat
- Remote Compact Disc Changer

Popular Colors: Torch Red, Arctic White, Sebring Silver Metallic and Black.



### Corvette convertible (not shown)

The Feature vehicle is the "image" model Chevrolet will profile most in its advertising. Generally, this vehicle does the best job of capturing attention and creating consumer awareness.

The Feature vehicle for 1998 is the new, fifth-generation Corvette convertible. This model features a manually operated full-folding top (with standard heated glass rear window) that stows out of sight. Other standard features include:

- 5.7 Liter LS1 Aluminum Small Block V8 with Sequential Fuel Injection
- 4-Speed Automatic Transmission
- Traction Control
- Electronically Tuned AM/FM Stereo with Cassette Player, Bose Speakers and Digital Clock
- PASS-Key II Theft-Deterrent System
- Power Door Locks
- Power Windows with Driver's and Passenger Express-Down Feature
- Remote Function Actuation (RFA) Keyless Entry.

Lead Color: Torch Red.

© 1997. All information correct at time of printing.

**Trim Colors**

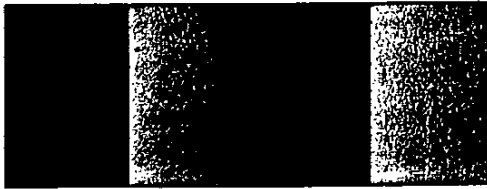

Leather seating surfaces available in Black, Light Gray, Firethorn Red and Light Oak.

**Seat Styles**



- A. Standard bucket seats with leather seating surfaces.
- B. Optional Sport bucket seats with leather seating surfaces and inflatable lumbar support.

**Wheels**

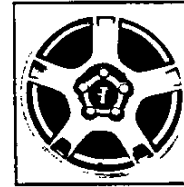

Corvette standard cast-aluminum wheel (17" front/18" rear).

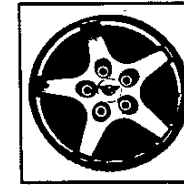

Corvette optional bronze-tone magnesium wheel (17" front/18" rear).

**Most Popular Exterior Colors with Corresponding Interior Color Availability**

INTERIOR MATERIAL COLORS				
	Black	Light Gray	Firethorn Red	Light Oak
EXTERIOR COLORS				
Torch Red	✓	✓		✓
Black	✓	✓	✓	✓
Arctic White	✓	✓	✓	✓
Light Carmine Red Metallic	✓	✓	✓	✓

See order guide for color availability by model.

**Most Popular Exterior Colors by Percentage**

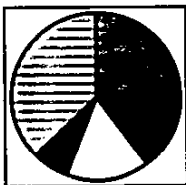

Clockwise, at left, are the four most anticipated popular Corvette colors for 1998, based on national sales volume. They are listed for reference only. To identify the top-selling colors in your area, by model, use the Retail Sales Analysis (RSA).

Torch Red	22%
Black	18%
Arctic White	16%
Light Carmine Red Metallic	7%
Other colors	37%

NOTE: New Corvette exterior colors are Light Pewter Metallic, Sport Gold Metallic and Medium Purple Pearl Metallic.



# Corvette

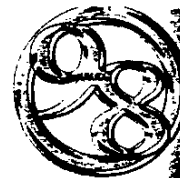

S.P.A.C.E. is an acronym to help organize and explain key features and benefits in five major categories a customer needs and wants. Overall improvements, changes and deletions are highlighted. Please review the supplied information, keeping in mind that this material is provided to you before production start-up — and is liable to change.

## S.P.A.C.E. *New-for-'98 features appear in bold.*



### SAFETY

• **AUTOMATIC DAYTIME RUNNING LAMPS** — make it easier for others to see your vehicle during the day. • **4-WHEEL ANTI-LOCK DISC BRAKE SYSTEM** — the Bosch anti-lock brake system (ABS5) helps reduce wheel lockup and helps the driver maintain steering control while braking, even on slippery surfaces. • **DRIVER AND PASSENGER AIR BAGS** — help reduce the chance of injury in certain moderate to severe frontal collisions. Always wear safety belts, even with air bags. • **SAFETY-CAGE CONSTRUCTION** — surrounds the entire passenger compartment. • **HIGH-STRENGTH PERIMETER FRAME** — helps improve structural rigidity and deliver a smooth ride. • **PASS-Key II THEFT-DETERRENT SYSTEM** — assures that only the owner's specially coded key starts the car.



### PERFORMANCE

• **5.7 LITER V8 LS1 ENGINE** — featuring 345 hp @ 5600 rpm and 350 lb.-ft. torque @ 4400 rpm, this small block engine boasts an all-aluminum block with a great power-to-engine weight ratio. • **ADVANCED FULLY INDEPENDENT SLA (SHORT/LONG ARM) SUSPENSION** — a preferred design for high-performance sports and racing cars. • **TWO SUSPENSION OPTIONS AVAILABLE** — Z51 Performance Handling Package and F45 Real Time Damping. • **LONGER WHEELBASE, WIDER TRACK** — an 8.3-inch longer wheelbase and a wider track (compared to fourth-generation models) helps provide greater stability. • **ELECTRONIC THROTTLE CONTROL** — an exclusive "drive-by-wire" system that provides a crisp response to driver input. • **GOODYEAR EAGLE F1 GS EXTENDED-MOBILITY TIRES** — may be driven up to 200 miles at 55 mph completely deflated, virtually eliminating the need for a spare.



### APPEARANCE

• **THREE NEW EXTERIOR COLORS** — Medium Purple Pearl Metallic, Sport Gold Metallic and Light Pewter Metallic. • **ONE NEW INTERIOR COLOR** — Light Oak (leather). • **MAGNESIUM WHEELS OPTION** — new bronze-tone lightweight wheels are available for both models. • **CONVERTIBLE MODEL** — has a simplified top operation, integral trunk compartment and heated-glass rear window. • **BASECOAT/CLEARCOAT PAINT** — not only provides a durable, lustrous finish, but reduces the severity of water-spotting and etching from acid rain. • **CORROSION-PROOF BODY PANELS** — Corvette models feature composite outer-body panels that will never rust. • **IMPACT-ABSORBING FRONT AND REAR 5-MPH BUMPERS** — with resilient covers, to resist minor dents and dings.



### COMFORT AND CONVENIENCE

• **ONE-PIECE ROOF PANEL** — magnesium frame helps make the panel light and easy to remove. • **REMOTE FUNCTION ACTUATION (RFA) SYSTEM** — lets driver automatically lock and unlock doors, turn on interior lights or unlock the rear hatch from up to 30 feet away. • **ADDITIONAL INTERIOR ROOM, ESPECIALLY IN THE FOOTWELL AREA** — the longer wheelbase, wider stance and rear-mounted transmission all contribute to more interior room and comfort than offered by earlier Corvette designs. • **WIDER DOOR OPENINGS** — for easier entry and exit, compared to the fourth-generation Corvette.



### EASY-TO-OWN

• **10,000-MILE RECOMMENDED OIL CHANGE INTERVAL** — for extended driving time between oil changes.\* • **ENGINE AIR FILTER MONITOR** — senses air restriction and indicates when to replace the engine air filter. • **SCOTCHGARD™ PROTECTOR** — on floor carpeting and mats, resists stains and makes cleanup easy. • **EXTENDED-LIFE AUTOMATIC TRANSMISSION FLUID** — never needs changing under normal driving conditions.\* • **PLATINUM-TIP SPARK PLUGS** — can last up to 100,000 miles.\* • **EXTENDED-LIFE ENGINE COOLANT** — has a first scheduled replacement interval of 5 years/150,000 miles, whichever comes first.\* • **GENUINE CUSTOMER CARE** — a 3-year/36,000-mile, no deductible, Bumper to Bumper limited warranty, 24-Hour Roadside Assistance via a toll-free hot line and Courtesy Transportation, if your vehicle ever needs warranty work.

\*Maintenance needs vary with different uses and driving conditions. See owner's manual for more information.

At participating dealerships.

Corvette

© 1997. All information subject to change without notice.

## Competitive Models

- Porsche 911
- Toyota Supra Turbo
- BMW Z3
- Mitsubishi 3000GT VR4
- Porsche Boxster.

## New for 1998

- The all-new 1998 Corvette convertible is a true convertible. It features a heated back glass, integral trunk (big enough for two sets of golf clubs) and upper-body modifications to accommodate the manually operated, easily folded convertible top. A five-bow pressurized design eliminates the need for latches at the rear of the top. The design also makes the top easy to raise or lower. The driver simply pushes a button which automatically lowers the windows part-way via the driver's Express-Down feature. The top is then easily lowered by the driver from outside the vehicle.
- An all-new air filter-life monitor senses air restriction and notifies the owner when it's time for a filter replacement.
- New magnesium bronze-tone wheels are available on all models for 1998. These wheels weigh less than standard aluminum wheels and offer a unique appearance.

Corvette

Feature Availability		
	Corvette coupe	Corvette convertible
<b>INTERIOR</b>		
Air Bag - Driver and Passenger	S	S
Air Conditioning - with CFC-Free Refrigerant	S	S
- Electric Dual-Zone	O	O
Console - Center with Cup Holder, Ashtray, Convenience Tray and Cassette/CD Storage	S	S
Defogger - Rear-Window	S	S
Door Locks - Power	S	S
Gauges, Analog - Speedometer, Fuel, Tachometer and Odometer	S	S
Low Tire Pressure Warning System	S	S
Luggage Shade and Parcel Net - Luggage-Area	O	NA
Memory Package - "Remembers" Outside Mirrors, Radio, Heater/Defroster/Air Conditioning and Driver Power-Seat Settings	O	O
PASS-Key II Theft-Deterrent System	S	S
Remote Function Actuation System (includes Keyless Entry)	S	S
Scotchgard™ Protector (on floor covering)	S	S
Seat - 6-Way Power Driver	S	S
- 6-Way Power Passenger	O	O
- Bucket, with Leather Seating Surfaces	S	S
- Sport Bucket, Adjustable with Leather Seating Surfaces (includes Inflatable Lumbar Support)	O	O
Speed Control - Electronic with Resume Speed	S	S
Steering Column - Tilt-Wheel™ Adjustable	S	S
Stereo - AM/FM with Cassette Player and Bose Speakers	S	S
- AM/FM with CD Player and Bose Speakers	O	O
- 12-Disc Remote CD Changer	O	O
Windows - Power with Driver's and Passenger Express-Down Feature	S	S
Wipers - Intermittent Variable	S	S
<b>EXTERIOR</b>		
Convertible Top - Manual with Heated Rear Glass Window	NA	S
Daytime Running Lamps - Automatic	S	S
Exhaust System - Aluminized Stainless-Steel	S	S
Foglamps	O	O
Mirrors - Outside Dual Body-Color Heated Remote Electric	S	S
Moldings - Body-Side	O	O
Paint - Basecoat/Clearcoat	S	S
Tires - Front, Extended Mobility P245/45ZR-17	S	S
- Rear, Extended Mobility P275/40ZR-18	S	S
Wheels - Cast Aluminum, 17" Front/18" Rear	S	S
- Magnesium, 17" Front/18" Rear	O	O
<b>FUNCTIONAL</b>		
Air Filter-Life Monitor	S	S
Brakes - Bosch 4-Wheel Anti-Lock (ABS)	S	S
- Power, Front and Rear Disc	S	S
Engine - 5.7 Liter LS1 Aluminum Small Block V8 SFI	S	S
Fuel Capacity - 19.1-Gallon	S	S
Suspension - 4-Wheel Independent SLA	S	S
Suspension - Z51 Performance Handling Package	O	O
Suspension - F45 Real Time Damping	O	O
Transmission - 4-Speed Electronically Controlled Automatic	S	S
- 6-Speed Manual	O	O

S — Standard. O — Optional (see your order guide for feature availability). NA — Not available.

# CORVETTE

## STANDARD EQUIPMENT SUMMARY

		1YY07	1YY67
<b><u>CHASSIS</u></b>			
AXLE RATIO:	2.73 (W/OPTIONAL M96 TRANSMISSION 3.42 AXLE IS STANDARD)	S	S
BRAKES:	4-WHEEL ANTI-LOCK/DISC FRONT AND REAR	S	S
ENGINE:	5.7 LITER SF1 V8	S	S
ENGINE ACCESS	REAR OPENING HOOD W/UNDERHOOD LAMP	S	S
IGNITION SYSTEM:	DISTRIBUTORLESS OPTI-SPARK	S	S
SPRINGS:	TRANSVERSE FIBERGLASS LEAF SPRINGS	S	S
STEERING:	SPEED SENSITIVE VARIABLE ASSIST RACK AND PINION	S	S
TRACTION CONTROL:	IMPROVES TRACTION AND ENHANCES VEHICLE STABILITY	S	S
TRANSMISSION:	4-SPEED AUTOMATIC W/BRAKE TRANS SHIFT INTERLOCK	S	S
<b><u>INTERIOR</u></b>			
AIR CONDITIONING:	MANUAL	S	S
CONSOLE:	CENTER WITH CUPHOLDER, ASHTRAY, COIN TRAY, CASSETTE AND CD STORAGE	S	S
DEFOGGER:	REAR WINDOW	S	S
	SIDE WINDOWS	S	S
GLASS:	TINTED, SOLAR-RAY	S	S
GAGES	ELECTRONIC WHITE ANALOG GAGES AND MULTI-LANGUAGE DRIVER INFORMATION CENTER	S	S
KEYLESS ENTRY:	PASSIVE/ACTIVE REMOTE	S	S
MIRRORS:	REARVIEW, DAY/NIGHT WITH READING LAMPS	S	S
LIGHTING:	COURTESY INTERIOR, CARGO, CONSOLE AND GLOVEBOX	S	S
LOCKS:	POWER	S	S
	PASSKEY II THEFT DETERRENT SYSTEM	S	S
RADIO:	ELECTRONICALLY TUNED AM/FM STEREO RADIO W/SEEK-SCAN, DIGITAL CLOCK, STEREO CASSETTE TAPE AND BOSE SPEAKERS	S	S
RESTRAINT SYSTEM:	DRIVER AND FRONT PASSENGER AIR BAGS	S	S
FABRIC PROTECTOR:	SEAT AND FLOOR COVERING	S	S
SEATS:	LEATHER SEATING SURFACE BUCKET WITH LATERAL SUPPORT AND BACK ANGLE ADJUSTMENT	S	S
	POWER 6-WAY DRIVER SEAT	S	S
STEERING:	TILT WHEEL, SPORT, LEATHER WRAPPED	S	S
STORAGE:	LOCKABLE GLOVEBOX, CENTER CONSOLE AND THREE REAR COMPARTMENTS	S	S
VISORS:	DUAL LIGHTED MIRRORS	S	S
SPEED CONTROL:	ELECTRONIC WITH RESUME SPEED	S	S
WARNING LIGHT:	LOW OIL LEVEL	S	S
WINDOWS:	POWER WITH DRIVER AND PASSENGER EXPRESS DOWN	S	S

# CORVETTE

## STANDARD EQUIPMENT SUMMARY

1YY07 1YY67

### EXTERIOR

BODY STRUCTURE:	UNIFRAME-DESIGN W/CORROSION-RESISTANT COATING	S	S
HATCH:	REAR, FULL FRAMED W/INTERIOR REMOTE RELEASE	S	-
HEADLAMPS:	POWER-OPERATED RETRACTABLE HALOGEN	S	S
INDUCTION SYSTEM:	OUTSIDE AIR	S	S
INSULATION:	INSULATION PKG, ACOUSTIC	S	S
LIGHTS:	DAYTIME RUNNING	S	S
MIRRORS:	DUAL BODY COLORED, ELECTRIC, HEATED	S	S
PAINT:	BASE-COAT/CLEAR-COAT	S	S
ROOF PANEL:	ONE-PIECE REMOVABLE FIBERGLASS	S	-
TIRES:	P245/45ZR-17 FRONT, EXTENDED MOBILITY SPEED RATED EAGLE		
	F-1 GS TIRES	S	S
	P275/40ZR-18 REAR, EXTENDED MOBILITY SPEED RATED EAGLE		
	F-1 GS TIRES	S	S
WIPERS:	INTERMITTENT	S	S
WHEELS:	ALUMINUM 17 X 8.5 FRONT 5-SPOKE	S	S
	ALUMINUM 18 X 9.5 REAR 5-SPOKE	S	S

\*38.060

**MODEL 1YY07**

**CORVETTE COUPE**

\*Includes Destination and Handling Charges

<b>1SA</b>
<b>Base Equipment Group</b> <span style="float: right;"><b>x</b></span>

**ADDITIONAL OPTIONS**

**OPTION**

- ACKNOWLEDGMENTS:**
- R8S Multiple Order Numbers
  - R8T Preliminary Invoice
- AIR CONDITIONING:** Electronic Dual Zone
- AXLE:** 3.15 Performance Ratio (N/A MN6 Transmission)
- CONTINUOUSLY VARIABLE REAL TIME DAMPING:**
- The Handling Package for Ultimate Driver Comfort and Control through the use of a Driver Adjustable Ride Control System (Incls Standard Suspension Components and Delphi Adjustable Ride Control System) (N/A Z51 Performance Handling Package)
- EMISSIONS: (MUST SPECIFY) (Refer Emission Requirements Tab Section)**
- FE9 Federal Emission Requirements
  - NG1 New York, Massachusetts or Connecticut Emission Requirements
  - YF5 California Emission Equipments
  - NB8 CA, NY, MA or CT Emission Override (Reqs FE9 Emissions)
  - NC7 Federal Emission Override (Reqs YF5 or NG1 Emissions)
- FLOOR MATS:** Front
- FOG LAMPS**
- LICENSE PLATE FRAME:** Front
- LUGGAGE SHADE AND PARCEL NET**
- MOLDINGS:** Body Side
- MEMORY PACKAGE:** Remembers Settings for OSRV Mirrors, Radio, HVAC, and Driver Power Seat Settings (Reqs CJ2 Air Conditioning)
- Z51 PERFORMANCE HANDLING PACKAGE:** Performance Oriented Package For the Gymkhana/Autocross Enthusiast (Incls Stiffer Springs and Stabilizer Bars) (w/o MN6 Transmission Reqs G92 Axle) (N/A F45 Continuously Variable Real Time Damping)
- RADIO EQUIPMENT:**
- UN0 Delco Electronically Tuned AM/FM Stereo Radio, w/Seek-Scan, Automatic Tone Control, Compact Disc Player, Digital Clock, Theft Lock, and Speed Compensated Volume. Bose Speaker System
  - U1S Compact Disc Changer, Remote
- ROOF:**
- C2L Roof Package Includes Standard Solid Panel and Blue Transparent Panel
  - CC3 Top, Blue Transparent (Incl w/C2L Roof Package)
- SEATS: (MUST SPECIFY)**
- AR9 Bucket (Standard)
  - AQ9 Adjustable Bucket (Reqs AG2 Power Seat)
  - AG2 **SEATS, ADDITIONAL:** Power, 6-Way Passenger
- TRANSMISSION: (MUST SPECIFY)**
- MX0 4-Speed Automatic w/Brake Trans Shift Interlock
  - MN6 6-Speed Manual



# CORVETTE COUPE

## INTERIOR AND EXTERIOR COLOR AVAILABILITY CHART

**Please Note:** Below are the interior trim color and exterior paint combinations *recommended* by Chevrolet.  
However, any available interior trim color may be ordered with one of these exterior colors if that particular combination is desired by the customer.

TRIM LEVEL Seat Type	(a) SEAT Opt	INTERIOR COLORS			
		Black	Lt Gray	Firethorn Red	Light Oak
Leather Adjustable Sport Bucket	AR9	193	923	943	673
Leather Adjustable Sport Bucket	(b) AQ9	193	923	943	673
Exterior Colors Solid Paint	Color Code	RECOMMENDED INTERIOR TRIM COLORS			
Black	41U	x	x	x	x
Blue, Nassau (Met)	23U	x	x		x
Green, Fairway (Met)	87U	x	x		x
Pewter, Lt (Met)	11U	x	x	x	
Purple, Pearl, Med (Met)	95U	x	x		x
Red, Lt Carmine (Met)	53U	x	x	x	x
Red, Torch	70U	x	x		x
Silver, Sebring (Met)	13U	x	x	x	
White, Arctic	10U	x	x	x	x

(a) Seat Option AR9 or AQ9 Must Be Specified

(b) Reqs AG2 Power Seat

\*44,990 **MODEL 1YY67**

## CORVETTE CONVERTIBLE

\*Includes Destination and Handling Charges

<b>Base Equipment Group</b>	<b>1SB</b>
	<b>X</b>

### ADDITIONAL OPTIONS

#### OPTION

##### ACKNOWLEDGMENTS:

R8S Multiple Order Numbers

R8T Preliminary Invoice

CJ2 **AIR CONDITIONING:** Electric Dual Zone

G92 **AXLE:** 3.15 Performance Ratio (N/A MN6 Transmission)

F45 **CONTINUOUS VARIABLE REAL TIME DAMPING:**

The Handling Package for Ultimate Driver Comfort and Control through the use of a Driver Adjustable Ride Control System (Incls Standard Suspension Components and Delphi Adjustable Ride Control System) (N/A Z51 Performance Handling Package)

**EMISSIONS: (MUST SPECIFY) (Refer Emission Requirements Tab Section)**

FE9 Federal Emission Requirements

NG1 New York, Massachusetts or Connecticut Emission Requirements

YF5 California Emission Equipments

NB8 CA, NY, MA or CT Emission Override (Reqs FE9 Emissions)

NC7 Federal Emission Override (Reqs YF5 or NG1 Emissions)

B34 **FLOOR MATS:** Front

T96 **FOG LAMPS**

V49 **LICENSE PLATE FRAME:** Front

B84 **MOLDINGS:** Body Side

AAB **MEMORY PACKAGE:** Remembers Settings for OSRV Mirrors, Radio, HVAC, and Driver Power Seat (Reqs CJ2 Air Conditioning)

Z51 **PERFORMANCE HANDLING PACKAGE:** Performance Oriented Package For The Gymkhana/Autocross Enthusiast (Incls Stiffer Springs and Stabilizer Bars) (w/o MN6 Transmission Reqs G92 Axle) (N/A F45 Continuously Variable Real Time Damping)

##### RADIO EQUIPMENT:

UN0 Delco Electronically Tuned AM/FM Stereo Radio, w/Seek-Scan, Automatic Tone Control, Compact Disc Player, Digital Clock, Theft Lock, and Speed Compensated Volume w/Bose Speaker System

U1S Compact Disc Changer, Remote

##### SEATS: (MUST SPECIFY)

AR9 Bucket (Standard)

AQ9 Adjustable Bucket (Reqs AG2 Power Seat)

AG2 **SEATS, ADDITIONAL:** Power, 6-Way Passenger

##### TRANSMISSION: (MUST SPECIFY)

MX0 4-Speed Automatic w/Brake Trans Shift Interlock

MN6 6-Speed Manual

# CORVETTE CONVERTIBLE

## INTERIOR AND EXTERIOR COLOR AVAILABILITY CHART

**Please Note:** Below are the interior trim color and exterior paint combinations *recommended* by Chevrolet. However, any available interior trim color may be ordered with one of these exterior colors if that particular combination is desired by the customer.

TRIM LEVEL Seat Type	(a) SEAT Opt	INTERIOR COLORS			
		Black	Lt Gray	Firethorn Red	Light Oak
Leather Bucket	AR9	193	923	943	673
Leather Adjustable Sport Bucket	(b) AQ9	193	923	943	673
Exterior Color Solid Paint	Color Code	RECOMMENDED INTERIOR TRIM COLORS			
Black	41U	16T/41T/67T	16T/41T	16T/41T	16T/41T/67T
Blue, Nassau (Met)	23U	16T/41T	16T/41T		16T/41T/67T
Green, Fairway (Met)	87U	16T/41T/67T	16T/41T		16T/41T/67T
Pewter, Lt (Met)	11U	16T/41T	16T/41T	16T/41T	
Purple, Pearl, Med (Met)	95U	16T/41T/67T	16T/41T		16T/41T/67T
Red, Lt. Carmine (Met)	53U	16T/41/67T	16T/41T	16T/41T/67T	16T/41T/67T
Red, Torch	70U	16T/41T/67T	16T/41T		16T/41T/67T
Silver, Sebring (Met)	13U	16T/41T	16T/41T	16T/41T	
White, Arctic	10U	16T/41T/67T	16T/41T	16T/41T	16T/41T/67T

(a) Seat Option AR9 or AQ9 Must Be Specified

(b) Reqs AG2 Power Seat

Convertible Top Option Must Be Specified in "Plus" (+) Option Section of Order Worksheet.

WHITE..... 16T

BLACK.....41T

LIGHT OAK.....67T

# MANUFACTURERS MOTOR VEHICLE SPECIFICATIONS

METRIC (U.S. CUSTOMARY)

# 1998

Manufacturer	CHEVROLET MOTOR DIVISION GENERAL MOTORS CORPORATION	Vehicle Line	CORVETTE	
Mailing Address	30007 VAN DYKE WARREN, MI 48090-9065	Issued	Revised	

Direct questions concerning these specifications to the manufacturer listed above.

The information contained herein is prepared, distributed by, and is solely the responsibility of the vehicle manufacturing company to whose products it relates. This specification form was developed by the vehicle manufacturing companies under the auspices of the American Automobile Manufacturers Association.

The General Specifications herein are those in effect at date of compilation and are subject to change without notice or incurring obligation by the manufacturer.

## AAMA

American Automobile Manufacturers Association

Blank Forms Provided by Technical Affairs Division

# Specifications

## METRIC

### Table of Contents

---

1	Vehicle Models/Origin	ø	Indicates Format Change
2	Power Teams		From Previous Year
3	Engine		
4	Lubrication System		
4	Diesel System		
5	Cooling System		
6	Fuel System		
7	Vehicle Emission Control		
7	Exhaust System		
8-10	Transmission, Axles and Shafts		
11	Suspension		
12-13	Brakes, Tires and Wheels		
14	Steering		
15-16	Electrical		
17	Body – Miscellaneous Information		
17	Frame		
18	Glass		
18	Headlamps		
19	Climate Control System		
20-21	Convenience Equipment		
21	Trailer Towing		
22-24	Vehicle Dimensions		
25	Vehicle Fiducial Marks		
26	Vehicle Mass		
27	Optional Equipment Differential Mass (Weight)		
28-34	Vehicle Dimensions Definitions – Key Sheets		
35	Index		

---

#### NOTE:

1. This form uses both SI Metric units and U.S. Customary units. The metric unit of measure is presented first, and the U.S. Customary unit follows in parentheses.
2. UNLESS OTHERWISE INDICATED:
  - a. Specifications apply to standard models without optional equipment. Significant deviations are noted.
  - b. Nominal design dimensions are used throughout these specifications.
  - c. All linear dimensions are in millimeters (inches), and all mass (weight) specifications are in kilograms (pounds).
3. The General Specifications herein are those in effect at date of compilation and are subject to change without notice or incurring obligation by the manufacturer.
4. Additional Vehicle Dimensions (based in part on SAE J1100 "Motor Vehicle Dimensions") may be available from the manufacturer.

# MVMA Specifications

Vehicle Line CORVETTE  
 Model Year 1998 Issued \_\_\_\_\_ Revised (●) \_\_\_\_\_

METRIC (U.S. Customary)

## Vehicle Origin

Design & development (company)	G.M. Midsize Car Division
Where built (country)	U.S.A.
Authorized U.S. sales marketing representative	Chevrolet Motor Division

## Vehicle Models

Model Description & Drive (FWD / RWD / AWD / 4WD)*	Introduction Date	Make, Vehicle Models, Series, Body Type (Mfr's Model Code)	No. of Designated Seating Positions (Front / Rear)	Max. Trunk/Cargo Load-Kilograms (Pounds)	EPA Fuel Economy (City/Hwy)
CORVETTE 2-Door Coupe (RWD)		1YY07	2 (2/0)	45.4 (100)	17/24

\* FWD - Front Wheel Drive RWD - Rear Wheel Drive AWD - All Wheel Drive 4WD - Four Wheel Drive

# MVMA Specifications

Vehicle Line CORVETTE  
 Model Year 1998 Issued \_\_\_\_\_ Revised (●) \_\_\_\_\_

## METRIC (U.S. Customary)

### Power Teams

SAE J1349 Net bhp (brake horsepower) and Net Torque corrected to 77°F/25°C and 29.61 in. Hg/100 kPa atmospheric pressure.

		A	B	C	D	
<b>E N G I N E</b>	Engine Code	LS1	LS1	LS1		
	Displacement Liters (in <sup>3</sup> )	5.7 (346)	5.7 (346)	5.7 (346)		
	Induction system (FI, Carb, etc.)	Sequential Fuel Injection	Sequential Fuel Injection	Sequential Fuel Injection		
	Compression ratio	10.1:1	10.1:1	10.1:1		
	SAE Net at RPM	Power kW (bhp)	257 (345) @ 5600	257 (345) @ 5600	257 (345) @ 5600	
		Torque N • m (lb. ft.)	475 (350) @ 4400	475 (350) @ 5600	475 (350) @ 5600	
	Exhaust single, dual	Dual	Dual	Dual		
<b>T R A N S</b>	Transmission/ Transaxle	M30	MM6	M30		
	Effective Final Drive / Axle Ratio (std. first)	2.73	3.42	3.15		

### Series Availability

### Power Teams (A - B - C - D)

Model	Code	Standard	Optional
CORVETTE			
2-Door Hatchback	1YY07	B	A,B,C

# MVMA Specifications

Vehicle Line CORVETTE  
 Model Year 1997 Issued Revised (●)

## METRIC (U.S. Customary)

Engine Description 5.7 LITER LS1  
 Engine Code

### Engine - General

Type & description (inline, V, angle, flat, location, front, mid, rear, transverse, longitudinal, sohc, dohc, ohv, hemi, wedge, pre-chamber, etc.)	90 deg. V, Front, Longitudinal, OHV	
Manufacturer	General Motors Powertrain Group	
No. of cylinders	Eight	
Bore	99.0 mm	
Stroke	92.0 mm	
Bore Spacing (C/L to C/L)	111.8 mm	
Cylinder block material & mass kg. (lbs.) (machined)	Aluminum, 48.6 (107.1)	
Cylinder block deck height	234.7 mm	
Cylinder block length	519.0 mm	
Deck clearance (minimum) (above or below block)	Not Applicable	
Cylinder head material & mass kg. (lbs.)	Aluminum, 9.2 (20.3)	
Cylinder head volume cm <sup>3</sup> (inches <sup>3</sup> )	66.9 (4.08)	
Cylinder liner material	Cast Iron	
Head gasket thickness (compressed)	1.33 mm	
Minimum combustion chamber total volume cm <sup>3</sup> (inches <sup>3</sup> )	64.9 (3.96)	
Cyl. no. system (front to rear)*	L. Bank	1-3-5-7
	R. Bank	2-4-6-8
Firing order	1-8-7-2-6-5-4-3	
Intake manifold material & mass kg. (lbs.)**	Composite, 7.2 (15.9)	
Exhaust manifold material & mass kg. (lbs.)**	Stainless Steel, Right: 5.3 (11.7), Left: 5.2 (11.5)	
Knock sensor (number & location)	Two - Valley	
Fuel required unleaded, diesel, etc.	Unleaded	
Fuel antiknock index (R + M) + 2	87	
Engine Mounts	Quantity	Two
	Material and type (elastomeric, hydroelastic, hydraulic damper, etc.)	Hydraulic Damper
	Added isolation (sub-frame, crossmember, etc.)	One Crossmember
Total dressed engine mass (wt) dry***	Automatic: 208.4 kg ; Manual: 226.1 kg	

### Engine - Pistons

Material & mass, g (weight, oz.) - piston only	Aluminum, 44 (15.5)
--	---------------------

### Engine - Camshaft

Location	In Cylinder Block "V" Above Crankshaft	
Material & mass kg (weight, lbs.)	Steel, 4.4 (9.7)	
Drive type	Chain / belt	Chain
	Width / pitch	5.72/9.53 mm

\* Rear of engine - drive takeoff. View from drive takeoff end to determine left & right side of engine.

\*\* Finished state.

\*\*\* Dressed engine mass (weight) includes the following: All those items necessary to make the engine a complete ready-to-run unit.



# MVMA Specifications

Vehicle Line CORVETTE  
 Model Year 1998 Issued \_\_\_\_\_ Revised (●) \_\_\_\_\_

## METRIC (U.S. Customary)

Engine Description 5.7 LITER V8 LS1  
 Engine Code \_\_\_\_\_

### Engine - Valve System

Hydraulic lifters (std., opt., n.a.)	Standard
Valves	Number intake / exhaust
	Head O.D. intake / exhaust
	Eight/Eight
	50.8 / 39.4 mm

### Engine - Connecting Rods

Material & mass kg., (weight, lbs.)*	Powder Metal, 0.62 (1.4)
Length (axes C/L to C/L)	154.9 mm

### Engine - Crankshaft

Material & mass kg., (weight, lbs.)*	Cast Nodular Iron, 23.0 (50.7)
End thrust taken by bearing (no.)	Three
Length & number of main bearings	Five
Seal (material, one, two piece design, etc.)	Front
	Rear
	Teflon, One Piece
	Teflon, One Piece

### Engine - Lubrication System

Normal oil pressure kPa (psi) at engine rpm	415 (60) @ 5000
Type oil intake (floating, stationary)	Stationary
Oil filter system (full flow, part, other)	Full Flow
Capacity of c/case, less filter-refill-L (qt.)	5.6 (Six)

### Engine - Diesel Information (NOT APPLICABLE)

Diesel engine manufacturer	
Glow plug, current drain at 0°F.	
Injector nozzle	Type
	Opening pressure kPa (psi)
Pre-chamber design	
Fuel Injection pump	Manufacturer
	Type
Fuel injection pump drive (belt, chain, gear)	
Supplementary vacuum source (type)	
Fuel heater (yes/no)	
Water separator, description (std., opt.)	
Turbo manufacturer	
Oil cooler-type (oil to engine coolant; oil to ambient air)	
Oil filter	

### Engine - Intake System (NOT APPLICABLE)

Turbo charger - manufacturer	
Super charger - manufacturer	
Intercooler	

\* Finished State

# MVMA Specifications

Vehicle Line CORVETTE  
 Model Year 1998 issued \_\_\_\_\_ Revised (●) \_\_\_\_\_

## METRIC (U.S. Customary)

Engine Description  
 Engine Code

5.7 LITER V8 LS1

### Engine - Cooling System

Coolant recovery system (std., opt., n.a.)		Standard
Coolant fill location (rad., bottle)		Bottle
Radiator cap relief valve pressure kPa (psi)		103.0 (15.0)
Circulation thermostat	Type (choke, bypass)	Choke
	Starts to open at °C (°F)	86.0 (187.0)
Water pump	Type (centrifugal, other)	Centrifugal
	GMP 1000 pump rpm	10.5
	Number of pumps	One
	Drive (V-belt, other)	Poly V-Belt
	Bearing type	Double Row (Ball)
	Impeller material	Steel
Housing material		Cast Aluminum
By-pass recirculation type (inter., ext.)		Internal
Cooling System capacity	With heater - L (qt.)	Not Applicable
	With air conditioner - L (qt.)	MM6 11.8 M30 11.5
	Opt. equipment specify - L (qt.)	Not Applicable
Water jackets full length of cyl. (yes, no)		Yes
Water all around cylinder (yes, no)		Yes
Water jackets open at head face (yes, no)		No
Radiator core	Std., A/C, HD	A/C, Standard
	Type (cross-flow, etc.)	Cross-Flow
	Construction (fin & tube mechanical, braze, etc.)	Fin & Tube
	Material, mass kg (wgt., lbs.)	Aluminum Header, Tubes and Fins. 4.08 kg (10.0)
	Width	600.0 mm (23.6 in.)
	Height	438.0 mm (17.24 in.)
	Thickness	24 mm (All)
Fins per inch		3.0 (16.9 fpi)
Radiator end tank material		Plastic
Fan	Std., elec., opt.	Electric, Standard
	Number of blades & type (flex, solid, material)	Five-Blades and Ring Shroud, Plastic
	Number & location (front, rear of radiator)	Two Fans, Rear of Radiator
	Diameter & projected width	312 mm
	Ratio (fan to crankshaft rev.)	--
	Fan cutout type	Temperature and Pressure Sensor
	Drive type (direct, remote)	Direct
	RPM at idle (elec.)	2100
	Motor rating (wattage/elec.)	150 W - 2200 RPM
	Motor switch (type & location/elec.)	Temperature Sensor Located on Engine Pressure Sensor on A/C Liquid Tube
	Switch point (temp./pressure/elec.)	Various
Fan shroud (material)		Plastic

# MVMA Specifications

Vehicle Line CORVETTE  
 Model Year 1998 Issued \_\_\_\_\_ Revised (●) \_\_\_\_\_

## METRIC (U.S. Customary)

Engine Description  
 Engine Code

5.7 LITER V8 LS1

### Engine - Fuel System (See Supplemental page for details of Fuel Injection, Supercharger, Turbocharger, etc. if used.)

Induction type: carburetor, fuel injection system, etc.		Sequential Fuel Injection
Manufacturer		Bosch
Carburetor no. of barrels		Not Applicable
Idle A/F mix.		Preset - No Adjustment
Fuel injection	Point of injection (no.)	At Ports
	Constant, pulse, flow	Pulse
	Control (electronic, mech.)	Electronic - On Board Computer
	System pressure kPa (psi)	400.0 (58.0)
Idle speed-rpm (spec. neutral or drive and propane if used)	Manual	PCM Controlled
	Automatic	PCM Controlled
Intake manifold heat control (exhaust or water thermostatic or fixed)		None
Air cleaner type		Replaceable Paper Element
Fuel filter (type/location)		Inline / Replaceable / Near Fuel Tank
Fuel pump	Type (elec. or mech.)	Electric
	Location (eng., tank)	Tank
	Pressure range kPa (psi)	400 kPa
	Flow rate at regulated pressure L (gal)/hr @ kPa (psi)	29 gm/sec @ 400 kPa

### Fuel Tank

Capacity refill L (gallons)		75.7 (19.1)
Location (describe)		Under Rear Deck - Rear of Seat Back Between Side Rail and Tunnel
Attachment		Held By Aluminum Plate
Material & Mass kg. (weight lbs.)		Density Polyethylene 5.1 Kg each
Filler pipe	Location & material	Left Side Rear of Door
	Connection to tank	Left Side of Left Tank
Fuel line (material)		Aluminum
Fuel hose (material)		Viton
Return line (material)		Aluminum
Vapor line (material)		Aluminum
Extended range tank	Opt., n.s.	Not Applicable
	Capacity L (gallons)	Not Applicable
	Location & material	Not Applicable
	Attachment	Not Applicable
Auxiliary tank	Opt., n.s.	Not Applicable
	Capacity L (gallons)	Not Applicable
	Location & material	Not Applicable
	Attachment	Not Applicable
	Selector switch or valve	Not Applicable
Separate fill		Not Applicable

# MVMA Specifications

Vehicle Line CORVETTE  
 Model Year 1998 Issued \_\_\_\_\_ Revised (●) \_\_\_\_\_

## METRIC (U.S. Customary)

Engine Description  
 Engine Code

5.7 LITER V8 LS1

### Vehicle Emission Control

Type (air injection, engine modifications, other)		See Below	
Exhaust Emission Control	Air injection	Pump or pulse	Pump
		Driven by	Electric
		Air distribution (head, manifold, etc.)	Exhaust Manifold (Computer Command Control)
		Point of entry	Exhaust Manifold
	Exhaust Gas Recirculation	Type (controlled flow, open orifice, other)	Not Applicable
		Exhaust source	Not Applicable
		Point of exhaust injection (spacer, carburetor, manifold, other)	Intake Manifold
	Catalytic Converter	Type	Three-Way
		Number of	Two
		Locations(s)	Under Floor
		Volume L (in <sup>3</sup> )	1.4 (85.0)
		Substrate type	Monolith
		Noble metal type	Platinum, Rhodium
Noble metal concentration (g/cm <sup>3</sup> )		0.001917	
Crankcase Emission Control	Type (ventilates to atmosphere, induction system, other)		Induction System
	Energy source (manifold vacuum, carburetor, other)		Manifold Vacuum
	Discharges to (intake manifold, other)		Intake Manifold
	Air inlet (breather cap, other)		Throttle Body
Evaporative Emission Control	Vapor vented to (crankcase, canister, other)	From Fuel Tank To	Canister
		From Carburetor To	Not Applicable
	Vapor storage provision		Canister
Electronic system	Closed loop (yes/no)		Yes
	Open loop (yes/no)		No

### Engine - Exhaust System

Type (single, single with cross-over, dual, other)		Dual
Muffler no. & type, Muffler volume (liters), Material & Mass kg. (weight lbs.)		Reverse Flow, 10.9 Liters each Two, Aluminized Stainless Steel
OD		H-Pipe 63.5
Exhaust pipe	Branch o.d., wall thickness	
	RH/LH	63.5 x 1.5 mm (2.5" x 0.060 in.)
	Material & Mass kg. (weight lbs.)	Aluminized Stainless Steel
Intermediate pipe	o.d. & wall thickness	RH - LH
	Material	Aluminized Stainless Steel RH/LH 63.5 x 1.5 mm (2.5" x 0.060")
Tail pipe	o.d. & wall thickness	Single Wide Wall, 44.5 x 1.5 mm (1.75" x 0.060")
	Material	Aluminized Stainless Steel/RH & LH Outer
Exhaust System/Includes Take Down Pipes, Catalytic Converts, Intermediate Pipes, Mufflers and Tailpipes Mass KG (Weight #'s)		37.9 KG (83.38 Lbs.)

# MVMA Specifications

Vehicle Line CORVETTE  
 Model Year 1998 Issued \_\_\_\_\_ Revised (●) \_\_\_\_\_

## METRIC (U.S. Customary)

Engine Description  
 Engine Code

5.7 LITER V8 LT1

### Transmissions/Transaxle (Std., Opt., N.A.)

Manual 4-speed (manufacturer/country)	Not Applicable
Manual 5-speed (manufacturer/country)	Not Applicable
Manual 6-speed (manufacturer/country)	Borg-Warner / USA
Automatic (manufacturer/country)	Not Applicable
Automatic overdrive (manufacturer/country)	GM Powertrain Group, USA

### Manual Transmission/Transaxle

Number of forward speeds	Six	
Gear ratios	1st	2.66
	2nd	1.78
	3rd	1.30
	4th	1.00
	5th	0.74
	6th	0.50
	Reverse	2.90
Synchronous meshing (specify gears)	All Forward Gears and Reverse	
Shift lever location	Chassis Mounted	
Trans. case material & mass kg. (lbs.)*	Aluminum, 56.2 (124.0)	
Lubricant	Capacity L (qts.)	3.8 (4.01)
	Type recommended	Dexron III

### Clutch (Manual Transmission)

Clutch manufacturer	Luk, Inc.	
Clutch type (dry, wet; single, multiple disc)	297 mm Type - Dry Clutch - Push Type, Single Disc	
Linkage (hydraulic, cable, rod, lever, other)	Hydraulic Pre-Filled	
Max. pedal effort (nom. spring load) N (lbs.)	Depressed	145 N (32.6 lbs.)
	Released	90 N (20.2 lbs.)
Assist (spring, power/percent, nominal)	Spring	
Type pressure plate springs	Diaphragm	
Total spring load (nominal) N (lbs.)	11,500 N (Static) (2584 lbs.)	
Clutch facing	Facing mfg. & material coding	Valeo F-808
	Facing material & construction	Non-Asbestos Woven, Bonded Steel Backing
	Rivets per facing	32
	Outside x inside dia. (nominal)	297 x 198 mm (11.69 x 7.80 in.)
	Total eff. area cm <sup>2</sup> (in. <sup>2</sup> )	384.9 cm <sup>2</sup> (59.6")
	Thickness (pressure plate side/ty wheel side)	3.4 / 3.4 mm (0.134 / 0.134 in.)
	Rivet depth (pressure plate side/ty wheel side)	2.5 mm (0.098 in.)
Engagement cushion method	Cushion Springs	
Release bearing type & method lub.	Angular Contact Ball Bearing	
Torsional damping method, springs, hysteresis	Coil Spring Clutch Disc With Friction Damper	

\* Includes shift linkage, lubricant, and clutch housing. If other specify.

# MVMA Specifications

Vehicle Line CORVETTE  
 Model Year 1998 Issued \_\_\_\_\_ Revised (●) \_\_\_\_\_

## METRIC (U.S. Customary)

Engine Description  
 Engine Code

5.7 LITER V8 LS1

### Automatic Transmission/Transaxle

Trade Name		Hydra-Matic 4L60E
Type and special features (describe)		Four-Speed Automatic Overdrive 4th Gear. Lock Up Torque Converter Clutch
Shift mechanics		Hydraulic Clutches / Electronic Controls
Gear selector	Location (column, floor, other)	On Floor Console
	Ltr./No. designation (e.g. PRND21)	P-R-N-(D)-D-2-1
	Shift interlock (yes, no, describe)	Yes (Brake Interlock)
Gear ratios	1st	3.06
	2nd	1.63
	3rd	1.00
	4th	0.70 (Computer Controlled Torque Converter Clutch)
	5th	Not Applicable
	6th	Not Applicable
	Reverse	2.29
Final drive ratio		2.73 or 3.15
Max. upshift vehicle speed - drive range km/h (mph)		One-Two = 77 (48) Three-Four = 235 (146) Two-Three = 145 (90)
Max. upshift engine speed RPM		6000
Max. kickdown speed - drive range km/h (mph)		Four-Three = 216 (134) Three-Two = 126 (78) Two-One = 61 (38)
Min. overdrive speed km/h (mph)		56 (35)
Torque converter	Type	Three Element with Converter Clutch
	Torus design	Full function
	Number of elements	Three
	Max. ratio at stall	1.91
	Type of cooling (air, liquid)	Liquid
	Nominal diameter	298 mm
Capacity factor "K"		95
Pump type		Variable Displacement Vane
Lubricant	Capacity refill L (qts.)	4.8 (5.07)
	Type recommended	Dexron III
Oil cooler (std., opt., N.A., internal, external, air, liquid)		Standard, External, Liquid
Transmission mass kg (lbs.) & case material**		71.2 (dry) Cast Aluminum

### All Wheel / 4 Wheel Drive

(Not Applicable)

Description & type (part-time, full-time, 2/4 shift while moving, mechanical, elect., chain/gear, etc.)		
Transfer case	Manufacturer and model	
	Type and location	
Low-range gear ratio		
System disconnect (describe)		
Center differential	Type (bevel, planetary, w or w/o viscous bias, torsen, etc.)	
	Torque split (% front/rear)	

\* Input speed  $\div \sqrt{\text{torque}}$

\*\* Dry weight including torque converter. If other, specify.

# MVMA Specifications

Vehicle Line CORVETTE  
 Model Year 1998 Issued Revised (●)

## METRIC (U.S. Customary)

Engine Description 5.7 LITER V8 LS1  
 Engine Code

### Axle Ratio and Tooth Combinations

(See 'Power Teams' for axle ratio usage)

		AUTOMATIC - M30		MANUAL - MM6
Axle ratio (or overall top gear ratio)		2.73 (1.91)	3.15 (2.20)	3.42 (1.71)
Ring gear o.d.		205 (8.)		
No. of teeth	Pinion	15	13	12
	Ring gear	41	41	41

### Rear Axle Unit

Description		Getrag 625
Limited slip differential (type)		Disc Clutches
Drive pinion	Type	Hypoid
	Offset	44.45 (1.75)
No. of differential pinions		Two
Pinion / differential	Adjustment (shim, etc.)	Shim
	Bearing adjustment	Shim
Driving wheel bearing (type)		Not Available
Lubricant	Capacity L. (pt.)	1.7L (3.6)
	Type recommended	GL-5 Gear Lubricant EOW-90 w/ 0.12L 9985412 Limited Slip Friction Modifier

### Propeller Shaft - Rear Wheel Drive

Manufacturer		Type (straight tube, tube-in-tube, internal-external damper, etc.)		Straight Tube, External Damper (Auto)		Manual (No Dampner)	
Outer diam. x length* x wall thickness	Manual 4-speed transmission		Not Available				
	Manual 5-speed transmission		Not Available				
	Manual 6-speed transmission		55 mm x 1460.7 x 2.45 (2.16 x 57.50 x .096)				
	Overdrive						
	Automatic transmission		Aluminum 55 mm x 1503.8 x 2.45 (2.16 x 59.20 x .096)				
Intermediate bearing	Type (plain, anti-friction)		Not Available				
	Lubrication (fitting, prepack)		Not Available				
Slip yoke	Type		Splined				
	Number of teeth		Manual Trans		Automatic Trans - 26		
	Spline o.d.		28.38 (1.12 in.)				
Universal joints	Make and mfg. no.	Front	Not Available				
		Rear	Not Available				
	Number used		Two				
	Type (ball and trunnion, cross)						
	Rear attach (u-bolt, clamp, etc.)		Bolt				
Bearing	Type (plain, anti-friction)						
	Lubrication (fitting, prepack)						
Drive taken through (torque tube, arms or springs)			Torque Tube				
Torque taken through (torque tube, arms or springs)			Torque Tube				

\* Centerline to centerline of universal joints, or to centerline of rear attachment.

# MVMA Specifications

Vehicle Line CORVETTE  
 Model Year 1998 Issued \_\_\_\_\_ Revised (●) \_\_\_\_\_

## METRIC (U.S. Customary)

Model Code/Description And/Or  
 Engine Code/Description

2 DOOR 1YY07 HATCHBACK COUPE

### Suspension - General Including Electronic Controls

Car leveling	Standard/optional/not available		Not Applicable	
	Manual/automatic control		Not Applicable	
	Type (air/hydraulic)		Not Applicable	
	Primary/assist spring		Not Applicable	
	Rear only/4 wheel leveling		Not Applicable	
	Single/dual rate spring		Not Applicable	
	Single/dual ride heights		Not Applicable	
	Provision for jacking		See Page 11A	
Shock absorber damping controls	Standard/option/not available		Optional	
	Manual/automatic control		Automatic Control, 3 Programs	
	Number of damping rates		Variable Valving	
	Type of actuation (manual/electric motor/air, etc.)		Electric Motor	
	Sensors	Lateral acceleration		Not Applicable
		Deceleration		Not Applicable
		Acceleration		Not Applicable
Road surface		Yes		
Shock absorber (front & rear)	Type	FE1, FE3 - Monotube	F45 - Multitube	
	Make	Base	Sachs OPT: Delphi	
	Piston diameter	46.0 mm (1.81 in.)	36.0 mm, 45.0 mm	
	Rod diameter	10.0 mm (0.393 in.)	11.0 mm	

### Suspension - Front

Type and description		See Page 11A
Travel	Full jounce (define load condition)	90.0 mm (3.46 in.), Metal to Metal
	Full rebound	90.0 mm (3.58 in.)
Spring	Type (coil, leaf, other & material)	Monoleaf, Filament Wound Glass - Epoxy Composite
	Insulators (type & material)	Pivot: Rubber Mounted
	Size (Leaf: length & width; Coil: design height & i.d.; Bar: length & diameter)	Leaf: 1152 mm x 90 mm Coil & Bar - Not Applicable
	Spring rate N/mm (lb./in.)	FE1 & F45 - 77.2, 79.8; FE3 - 92.2 N/mm
	Rate at wheel N/mm (lb./in.)	FE1 & F45 - 18.5, 18.7; N/mm, FE3 - 20.0 n/M
Stabilizer	Type (link, linkless, frameless)	Link - B/JNT Composite Material
	Material & O.D. bar/tube, wall thickness	FE1 & F45 - 23 DIA Tube, 3.8 Wall FE3 - 25.4 DIA Tube, 4.0 Wall

### Suspension - Rear

Type and description		See Page 11A	
Travel	Full jounce (define load condition)	96 mm	
	Full rebound	90 mm	
Spring	Type (coil, leaf, other & material)	Monoleaf, Filament Wound Glass - Epoxy Composite	
	Size (Leaf: length & width; Coil: design height & i.d.; Bar: length & diameter)	Leaf: 1273.5 mm x 90.0 mm Coil & Bar - Not Applicable	
	Spring rate N/mm (lb./in.)	FE1, F45 - 103 N/mm, FE3 - 113 N/mm	
	Rate at wheel N/mm (lb./in.)	FE1, F45 - 23.2 N/mm, FE3 - 25.2 N/mm	
	Insulators (type & material)	Neoprene	
	If leaf	No. of leaves	Monoleaf
		Shackle (comp. or tens.)	Tension
Stabilizer	Type (link, linkless, frameless)	Ball Joint Link	
	Material & O.D. bar/tube, wall thickness	Material: SAE 4130, Bar Size: FE1 - 19.1 mm x 2.0 mm, FE3 - 21.7 x 3.0	
Track bar (type)		None	



# MVMA Specifications

Vehicle Line CORVETTE  
Model Year 1998 Issued \_\_\_\_\_ Revised (●) \_\_\_\_\_

## METRIC (U.S. Customary) SUPPLEMENTAL PAGE

---

### PROVISIONS FOR JACKING:

*Place Jackhead Between Locator Triangles on Rocker Flange Nearest to Tire Being Changed. Make Sure Jack is Under The Steel Flange.*

### SUSPENSION - FRONT

*Independent SLA, Aluminum Upper and Lower Control Arms and Steering Knuckle, Transverse Composite Monoleaf Spring and Steel Stabilizer, Tubular Steel Stabilizer Bar.*

### SUSPENSION - REAR

*Independent SLA, Aluminum Upper and Lower Control Arms and Steerng Knuckle, Transverse Composite Monoleaf Spring, Tubular Steel Stabilizer Bar, Steel Steering Link.*

# MVMA Specifications

Vehicle Line CORVETTE  
 Model Year 1998 issued \_\_\_\_\_ Revised (●) \_\_\_\_\_

## METRIC (U.S. Customary)

Model Code/Description And/Or  
 Engine Code/Description

2-DOOR HATCHBACK COUPE 1YY07

### Brakes - Service

Description		Hydraulic Power Brake Front and Rear Disc		
Manufacturer and brake type (std., opt., n.a.)	Front (disc or drum)	PBR Pin Guided Aluminum Caliper		
	Rear (disc or drum)	PBR Pin Guided Aluminum Caliper		
Valving type (proportion, delay, metering, other)		Proportioning Valve		
Power brake (std., opt., n.a.)		Standard		
Booster type (remote, integral, vac., hyd., etc.)		Vac 220.0 mm Tandum 613.10 cm <sup>2</sup>		
Vacuum	Source (inline, pump, etc.)	Engine Plenum		
	Reservoir (volume in. <sup>3</sup> )	Not Applicable		
	Pump-type (elec., gear or belt driven)	Not Applicable		
Traction assist	Operational speed range	All Speeds		
	Type (engine or brake intervention)	Engine and Brake Intervention		
Antilock device	Front/rear (std., opt., n.a.)	Standard Front and Rear		
	Manufacturer	Bosch ABS/ASR V/Delphi		
	Type (electronic, mech.)	Electrohydraulic		
	Number sensors or circuits	(Four) Wheel Sensors		
	Number antilock hydraulic circuits	Four (Two Front and Two Rear) Hydraulic		
	Integral or add-on system	Add-On		
	Yaw control (yes, no)	Yes		
Hyd. power source (elec., vac., mtr., pwr., strg.)		Electronic Motor Pump		
Effective area cm <sup>2</sup> (in. <sup>2</sup> )*		Front Linings 144 (22.3); Rear Linings 56 (8.7) (W/O Grooves)		
Gross Lining area cm <sup>2</sup> (in. <sup>2</sup> )** (F/R)		Front Linings 146 (22.6); Rear Linings 56 (8.7) (W/O Grooves)		
Swept area cm <sup>2</sup> (in. <sup>2</sup> )** (F/R) Axle Sums		Front 1696 (263); Rear 1018 (158)		
Rotor	Outer working diameter	F/R	Front 320 mm; Rear 300 mm	
	Inner working diameter	F/R	Front 220 mm; Rear 240 mm	
	Thickness	F/R	Front 32 mm; Rear 26 mm	
	Material & type (vented/solid)	F/R	HCR Iron Vent Front & Rear	
Drum	Diameter & width	F/R	Not Applicable	
	Type and material	F/R	Not Applicable	
Wheel cylinder bore		Front Dual Piston 40.5 mm (1.6 in.) Rear 45.0 mm (1.8 in.)		
Master cylinder	Bore/stroke	F/R	Front 25.4 / 20.6 mm (.93/.80 in.) Rear 25.4 / 12.6 mm	
Pedal arc ratio		4.0:1		
Line press. at 445 N (100 lb.) pedal load [kPa (psi)]		W/Power Front (1250), Rear (750)		
Lining clearance		F/R	Front and Rear Self Adjusting	
Brake lining	Front wheel	Bonded or riveted (rivets/seg.)		Integral Mold
		Rivet Size		Not Applicable
		Manufacturer		Japan Brake Industries
		Lining code *****		JB NF42FF
		Material		Non-Asbestos Organic
	Rear wheel	****	Primary or out-board	Front 161 x 50 x 9.5 mm (5.31 x 1.57 x 0.37 in.)
		Size	Secondary or in-board	Front 161 x 50 x 9.5 mm (5.31 x 1.57 x 0.37 in.)
		Shoe thickness (no lining)		5.0 mm (0.236 in.)
		Bonded or riveted (rvts/seg.)		Integral Mold
		Manufacturer		Japan Brake Industries
Rear wheel	Lining code *****		JB NF42FF	
	Material		Non-Asbestos Organic	
	****	Primary or out-board	105 x 30 x 10.5 mm (4.25 x 1.38 x 0.33 in.)	
	Size	Secondary or in-board	105 x 30 x 10.5 mm (3.70 x 1.38 x 0.33 in.)	
	Shoe thickness (no lining)		5.0 mm	

\* Excludes rivet holes, grooves, chamfers, etc.

\*\* Includes rivet holes, grooves, chamfers, etc.

\*\*\* Total swept area for four brakes. (Drum brake: Widest lining contact width for each brake x its contact circumference.)  
 (Disc brake: Square of Outer Working Dia. minus Square of inner Working Dia. multiplied by Pi/2 for each brake.)

\*\*\*\* Size for drum brakes includes length x width x thickness. \*\*\*\*\*Manufacturer I.D., catalog for formulation designation and coefficient of friction classification.

# MVMA Specifications

Vehicle Line CORVETTE  
 Model Year 1998 Issued \_\_\_\_\_ Revised (●) \_\_\_\_\_

## METRIC (U.S. Customary)

Model Code/Description And/Or  
 Engine Code/Description

2-DOOR HATCHBACK COUPE 1YY07

### Tires And Wheels (Standard)

Tires	Size (service description)		P245/45ZR17 Front; P275/40ZR18 Rear. Base	
	Type (bias, radial, steel, nylon, etc.)		High Speed Steel Belted Radial Eagle F1 GS (Goodyear), Unidirectional & Symmetrical	
	Inflation pressure (cold) for recommended max. vehicle load	Front kPa (psi)	240	207
		Rear kPa (psi)	240	207
Rev./mile at 70 km/h (45 mph)		806 Front; 777 Rear		
Wheels	Type & material		Aluminum Alloy Road Wheels Magnesium for Europe, Japan	
	Rim (size & flange type)		17 x 8.5 Front, 18 x 9.5 Rear	
	Wheel offset		56.0 mm Alum 60.0 Mg Frt., 61.0 mm Alum 65.0 Mg Rear	
	Attachment	Type (bolt or stud & nut)	Stud	
		Circle diameter	120.7 mm (4.75 in.)	
Number & size		Five Hex Nuts, One Anti-Theft: M12 x 1.5 - 6H		
Spare	Tire and wheel		No Spare	
	Storage position & location (describe)		Not Applicable	

### Tires And Wheels (Optional)

Tire size (service description)		
Type (bias, radial, steel, nylon, etc.)		
Wheel (type & material)		Magnesium Alloy Road Wheels
Rim (size, flange type and offset)		17 x 8.5 Front, 18 x 9.5 Rear
Tire size (service description)		
Type (bias, radial, steel, nylon, etc.)		
Wheel (type & material)		
Rim (size, flange type and offset)		
Tire size (service description)		
Type (bias, radial, steel, nylon, etc.)		
Wheel (type & material)		
Rim (size, flange type and offset)		
Tire size (service description)		
Type (bias, radial, steel, nylon, etc.)		
Wheel (type & material)		
Rim (size, flange type and offset)		
Spare tire and wheel size		
(if configuration is different than road tire or wheel, describe optional spare tire and/or wheel location & storage position)		Same As Standard

### Brakes - Parking

Type of control		Hand
Location of control		Center Console
Operates on		Rear Wheels
If separate from service brakes	Type (internal or external)	Internal
	Drum diameter	190 mm
	Lining size (length x width x thickness)	400 x 25 x 3 mm

# MVMA Specifications

Vehicle Line CORVETTE  
 Model Year '998 Issued \_\_\_\_\_ Revised (●) \_\_\_\_\_

## METRIC (U.S. Customary)

Model Code/Description And/Or  
 Engine Code/Description

2-DOOR HATCHBACK COUPE 1YY07

### Steering

Manual (std., opt., n.a.)		Not Available		
Power (std., opt., n.a.)		Standard		
Speed-sensitive (std., opt., n.a.)		Standard		
4-wheel steering (std., opt., n.a.)		Not Available		
Adjustable steering wheel/column (tilt, telescope, other)	Type	Tilt		
	Manufacturer	Delphi Saginaw Steering Systems		
	(std., opt., n.a.)	Standard		
Wheel diameter** (W9) SAE J1100	Manual	Not Available		
	Power	380.0 mm (15.0 in.)		
Turning diameter m (ft.)	Outside front	Wall to wall (l. & r.)	12.6 (41.3)	
		Curb to curb (l. & r.)	12.2 (40.0)	
	Inside rear	Wall to wall (l. & r.)	Not Available	
		Curb to curb (l. & r.)	Not Available	
Scrub Radius*				
Manual	Gear	Type	Not Available	
		Manufacturer	Not Applicable	
	Ratios	Gear	Not Applicable	
		Overall	Not Applicable	
	No. wheel turns (stop to stop)		Not Applicable	
Power	Type (coaxial, elec. hyd., etc.)		Alloy Rack and Pinion Hydraulic	
	Manufacturer		Delphi Saginaw Steering Systems	
	Gear	Type	End Take-Off	
		Ratios	Overall	16.2:1
	Pump (drive)		Accessory Belt Driven, Lt. Wt. Transverse Compact Pump	
	No. wheel turns (stop to stop)		2.66 Turns	
Linkage	Type		End Take-Off	
	Location (front or rear of wheels, other)		Front of Wheel	
	Tie rods (one or two)		Two	
Steering axis	Inclination at camber (deg.)			
	Bearings (type)	Upper	Plastic lined lube for life	
		Lower	Plastic lined lube for life	
		Thrust	Lower Ball Joint	
Steering spindle/knuckle & joint type		Upper and Lower Ball Joints		

\* The horizontal distance in the front elevation between wheel centerline and kingpin (ball joint) axis at ground.

\*\* See Page 23.

# MVMA Specifications

Vehicle Line CORVETTE  
 Model Year 1998 Issued \_\_\_\_\_ Revised (●) \_\_\_\_\_

## METRIC (U.S. Customary)

Model Code/Description And/Or  
 Engine Code/Description

2-DOOR HATCHBACK COUPE 1YY07

### Wheel Alignment

Front wheel at curb mass (wt.)	Service checking	Caster (deg.)	6.1 (±) 0.5
		Camber (deg.)	-0.2 (±) 0.5
		Toe-in outside track mm (in.)	0.04 (±) 0.1 Toe in each Wheel
	Service reset*	Caster (deg.)	0.04 (±) 0.1 Toe in each Wheel
		Camber (deg.)	0.04 (±) 0.1 Toe in each Wheel
		Toe-in mm (in.)	0.04 (±) 0.1 Toe in each Wheel
	Periodic M.V. insp.	Caster (deg.)	0.04 (±) 0.1 Toe in each Wheel
		Camber (deg.)	0.04 (±) 0.1 Toe in each Wheel
		Toe-in mm (in.)	0.04 (±) 0.1 Toe in each Wheel
Rear wheel at curb mass (wt.)	Service checking	Camber (deg.)	0.18 (±) 0.5
		Toe-in outside track mm (in.)	0.0 (±) 0.1 Each Wheel
	Service reset*	Camber (deg.)	0.0 (±) 0.1 Each Wheel
		Toe-in mm (in.)	0.0 (±) 0.1 Each Wheel
	Periodic M.V. insp.	Camber (deg.)	0.0 (±) 0.1 Each Wheel
		Toe-in mm (in.)	0.0 (±) 0.1 Each Wheel

\* Indicates pre-set, adjustable, trend set or other.

### Electrical - Instruments and Equipment

Speedometer	Type (analog, digital, std., opt.)	Analog, Standard	
	Trip odometer (std., opt., n.a.)	Standard	
Head-up display	Standard, optional, not available		Not Available
	Type	Secondary, opto-electronic	Not Available
	Speedometer	Digital	Not Available
	Status/warning indicators	Turn signals, high beam, low fuel, check gauges	Not Available
	Brightness control	Day / night mode, adjustable	Not Available
EGR maintenance indicator		Not Available	
Charge indicator	Type	Analog Display, Digital	
	Warning device (light, audible)	Standard - Warning Audible, Digital, Check Gage Light	
Temperature indicator	Type	Analog Display, Digital	
	Warning device (light, audible)	Standard - Warning Audible, Digital, Check Gage Light	
Oil pressure indicator	Type	Analog Display	
	Warning device (light, audible)	Standard - Warning Audible, Digital, Check Gage Light	
Fuel indicator	Type	Analog	
	Warning device (light, audible)	Standard - Warning - Reserve, Low, Audible, Check Gage Light	
Windshield wiper	Type (standard)	Intermittent Control System	
	Type (optional)	Not Available	
	Blade length	508.0 mm (22 in.)	
	Swept area cm <sup>2</sup> (in. <sup>2</sup> )	6920 (1072.9)	
Windshield washer	Type (standard)	Push Button - Manual	
	Type (optional)	Not Available	
	Fluid level indicator (light, audible)	Not Available	
Rear window wiper, wiper/washer (std., opt., n.a.)		Not Available	
Horn	Type	Air Horn	
	Number used	Two	
Other		See Page 15A	

# MVMA Specifications

Vehicle Line CORVETTE

Model Year 1998

Issued \_\_\_\_\_

Revised (●) \_\_\_\_\_

## METRIC (U.S. Customary) SUPPLEMENTAL PAGE

---

These Lights in the IP Cluster:

- Traction Light
- Check Gages Light
- Security Light
- Check Engine
- Shift One to Four Light
- ABS Light
- Safety Belt Light
- Park Brake Light
- Air Bag Light

The Center of the Cluster Shows:

- Speedometer
- Odometer
- Fuel Gage
- Driver Information Center
- Volt Gage
- Oil Pressure Gage
- Coolant Temperature Gage

These Telltales illuminate in The Driver Information Center (DIC)

- Low Oil Pressure
- High Oil Temperature Reduce Engine RPM
- Engine Protection Reduce Engine RPM
- Upshift Now
- Coolant Over Temp
- Reduced Engine Power
- Maximum Speed XX MPH
- Shocks Inoperative / Service Ride Control
- High Trans Temp
- Flat Tire - LF, RF, LR or RR
- High Tire Pressure - LF, RF, LR or RR
- Low Tire Pressure - LF, RF, LR or RR
- Low Oil Level
- Low Coolant Level
- Low Voltage
- High Voltage
- Low Brake Fluid
- Change Oil Now
- Service Traction System
- Service Column Lock
- Pull Key - Wait 10 Sec.
- Service Ride Control
- Change System Fault
- Service Vehicle Soon
- Low Fuel
- Low Washer Fluid
- Hatch Ajar
- Door Ajar
- Tonneau Ajar
- Reserve Fuel
- Change Oil Soon
- Cruise Set XX MPH
- Cruise Off
- Brake Before Shift
- Traction System on or off
- Traction System Active
- Service ABS

# MVMA Specifications

Vehicle Line CORVETTE  
 Model Year 1998 Issue# \_\_\_\_\_ Revised (●) \_\_\_\_\_

## METRIC (U.S. Customary)

Engine Code/Description 5.7 LITER V8 LS1

### Electrical - Supply System

Battery	Manufacturer	Delphi Energy & Engine Management Systems
	Model, std., (opt.)	655
	Voltage	12
	Amps at 0° F. cold crank	525
	Minutes-reserve capacity	90
	Amps/hrs.-20 hr. rate	54
	Location	Engine Compartment Directly Behind Right Wheel Opening
Alternator	Manufacturer	Valeo
	Rating (idle/max. rpm)	70-110 Amps @ 1600-6000 grpm
	Ratio (alt. crank/rev.)	2.79:1
	Output at idle (rpm, park)	70 Amps @ 1600 grpm
	Optional (type & rating)	Not Available
Regulator	Type	Integral with Alternator

### Electrical - Starting System

Motor	Manufacturer	Delphi
	Current drain _____ °C (°F)	350 Amps
	Power rating kw (hp)	1.6 (2.1)
Motor drive	Engagement type	Positive Shift Solenoid
	Pinion engages from (front, rear)	Front

### Electrical - Ignition System

Type	Electronic (std., opt., n.a.)	Standard	
	Other (specify)	Coil-Near Plug	
Coil	Manufacturer	Nippondenso	
	Model	5-099700-456	
	Current	Engine stopped - A	--
		Engine idling - A	--
Spark plug	Manufacturer	Delphi - E	
	Model	41-831	
	Thread (mm)	14.0	
	Tightening torque N-m (lb. ft.)	9-20 (7-15)	
	Gap	1.5 mm	
	Number per cylinder	One	
Distributor	Manufacturer	Not Applicable	
	Model	Not Applicable	

### Electrical - Suppression

Locations & type	Internal Generator Capacitor, Non-Metallic High-Tension Cables, Resistor Spark Plugs, Ignition Coil By-Pass Capacitor, Internal AC Blower Motor & A/C Compression Diode, with Radio Provisions .
------------------	--

# MVMA Specifications

Vehicle Line CORVETTE  
 Model Year 1998 Issued \_\_\_\_\_ Revised (●) \_\_\_\_\_

## METRIC (U.S. Customary)

Model Code/Description

2-DOOR HATCHBACK COUPE 1Y07

### Body

Structure	Integral Perimeter Frame - Birdcage Forms Strong Unitized Body Structure. Aerodynamically Shaped Body with Deeply Angled Windshield (64 deg.). All Major Body Panels SMC Reinforced Composite with Molded-In Coating. Single Lift Off Roof Panel (Coupe) Effective Pass; Compartment insulation, Tinted Glass All Around. "Unibase" Paint Process. Final Clear Coat Paint Finish.
Bumper system front -rear	Front - Full-Width Polypropylene Foam Energy Absorber Backed Up by an Impact Bar of Strong Continuous Glass Fiber Plastic. Body Color, Glass-Reinforced Rim Fascia. Rear-Full Width Polypropylene Foam Energy absorber. Body Color, Glass-Reinforced Rim Fascia. Extruded Aluminum Impact Bar.
Anti-corrosion treatment	All Encompassing Corrosion Protection Including Extensive Use of Aluminum; Galvanization; Use of Specially Treated Fasteners; Austenitic Stainless Steel or Specially Coated Brackets, Clamps, Clips and Braces; Use of Aluminized Steel, Dip Painted; Use of Materials that Resist Corrosion.

### Body - Miscellaneous Information

Type of finish (lacquer, enamel, other)	Water Borne High Solids Base Coat Enamel with High Solids Clear Coat	
Hood	Material & mass	Sheet Moulded Compound with Steel Reinforcements. 33.6 kg (74.1 lbs.)
	Hinge location (front, rear)	Front
	Type (counterbalance, prop)	Forward Hinged Hood
	Release control (internal, external)	Interior
Trunk lid	Material & mass	Not Applicable
	Type (counterbalance, other)	Not Applicable
	Internal release control (elec., mech., n.a.)	Not Applicable
Hatchback lid	Material & mass	Tempered, Tinted Safety Glass 19.05 kg. (42.0 lbs.)
	Type (counterbalance, other)	Dual Gas Struts
	Internal release control (elec., mech., n.a.)	Electric Release, Standard (Driver Door and Console Glove Box and Key Fob).
Tailgate	Material & mass	Not Applicable
	Type (drop, lift, door)	Not Applicable
	Internal release control (elec., mech., n.a.)	Not Applicable
Vent window control (crank, friction, pivot, power)	Front	Not Available
	Rear	Not Available
Window regulator type (cable, tape, flex drive, etc.)	Front	Drive
	Rear	Not Available
Seat cushion type (e.g., 60/40 bucket, bench, wire, foam, etc.)	Front	Bucket Seat, Leather Seating Surface
	Rear	Not Available
	3rd seat	Not Available
Seat back type (e.g., 60/40 bucket, bench, wire, foam, etc.)	Front	Bucket Seat, Leather Seating Surface
	Rear	Not Available
	3rd seat	Not Available

### Frame

Type and description (separate frame, unitized frame, partially-unitized frame)	All-Welded Steel Body-Frame Construction, 100% Galvanized Bolt-On Front Crossmember to Allow Bottom Loaded Engine.
---	--



# MVMA Specifications

Vehicle Line CORVETTE  
 Model Year 1998 issued \_\_\_\_\_ Revised (●) \_\_\_\_\_

## METRIC (U.S. Customary)

Model Code/Description

2-DOOR HATCHBACK COUPE 1YY07

### Restraint System

Seating Position			Left	Center	Right
Active	Type & description (lap & shoulder belt, lap belt, etc.)  Standard / Optional	First seat	3-Point Active Lap & Shoulder Belt		3-Point Active Lap & Shoulder Belt
		Second seat			
		Third seat			
Passive	Type & description (air bag, motorized-2-point belt, fixed belt, knee bolster, manual-lap belt)  Standard / Optional	First seat	Air Bag Standard		Air Bag Standard
		Second seat			
		Third seat			
<b>Glass</b>		<b>SAE Ref.No.</b>			
Windshield glass exposed surface area cm <sup>2</sup> (in. <sup>2</sup> )		S1	8710.0 (1350.0)		8710 (1350)
Side glass exposed surface area cm <sup>2</sup> (in. <sup>2</sup> ) - total 2 sides		S2	4007.2 (621.1)		4007.2 (621.1)
Backlight glass exposed surface area cm <sup>2</sup> (in. <sup>2</sup> )		S3	6205.0 (971.8)		2554.8 (397.0)
Total glass exposed surface area cm <sup>2</sup> (in. <sup>2</sup> )		S4	18922.2 (2932.9)		15272.0 (2367.1)
Windshield glass (type/thickness)			Curved - Laminated Plate - Tinted - 5.4 mm		
Side glass (type/thickness)			Curved - Temperature Plate - Tinted - 5.0 mm		
Backlight glass (type/thickness)			Curved - Tempered Plate - Tinted (Hatchback) 4.0 mm Glass		
Tinted (yes/no, location)					
Solar control (yes/no, coated/batched, location)					

### Headlamps

Description (sealed beam, halogen, replaceable bulb, etc.)	Sealed Beam
Shape	Rectangular
Lo-beam type (2A1, 2B1, 2C1, etc.)	2B1 on Both - One Capsule Per Side
Quantity	
Hi-beam type (1A1, 2A1, 1C1, 2C1, etc.)	
Quantity	

# MVMA Specifications

Vehicle Line CORVETTE  
 Model Year 1998 Issued \_\_\_\_\_ Revised (●) \_\_\_\_\_

## METRIC (U.S. Customary)

Engine Code/Description

2-DOOR HATCHBACK COUPE 1YY07

### Climate Control System

Air conditioning (std., opt., man., auto.)		Manual A/C Standard Automatic A/C, Optional
Condenser	Type	Header Tube and Center
	Eff. face area (sq. mm.)	245,420
	Fins per inch	16.9 Fins/Inch
Evaporator	Type	Staggered Rib, Plate Type
	Eff. face area (sq. mm.)	48,387
	Fins per inch	14 Fins/Inch
Heater core	Material	Aluminum
	Eff. face area (sq. mm.)	29,060
	Fins per inch	11 Fins/Inch
Compressor	Type	Piston Type, Wobble Plate, Variable Displacement
	Displacement (cc.)	179 cc (LS1)
	Manufacturer	Delphi Thermal Systems
	A/C pulley ratio	1.43:1 (LS1)
Accumulator	Type	Accumulator/Dehydrator
	Height (mm.)	231
	Diameter (mm.)	93
Receiver	Type	Not Available
	Height (mm.)	Not Available
	Diameter (mm.)	Not Available
Refrigerant control (CCOT, TVS, etc.)		VDOT
Heater water valve (yes / no)		No
Refrigerant (R - 12, R - 134a, etc.)		R-134a
Charge level (lbs. - oz.)		1.625
Cold engine lockout switch (yes / no)		No
Wide open throttle cutout switch (yes / no)		No

# MVMA Specifications

Vehicle Line CORVETTE  
 Model Year 1998 Issued \_\_\_\_\_ Revised (●) \_\_\_\_\_

## METRIC (U.S. Customary)

Model Code/Description

2-DOOR HATCHBACK COUPE 1YY07

### Convenience Equipment (standard, optional, n.a.)

	Clock (digital, analog)	
	Compass / thermometer	Thermometer on C68
	Console (floor, overhead)	Standard Floor
	Defroster, electric windshield	Not Available
	Defroster, electric backlight	Standard
Electronic	Diagnostic monitor (integrated, individual)	Standard - ALCL (Assembly Line Communications Link); Integrated
	Instrument cluster (list instruments)	Speedo, Tach, Coolant Temps, Oil Pressure, Volts, Fuel
	Keyless entry	Passive, Active Standard
	Tripminder (avg. spd., fuel)	Range, Average and Instant MPG
	Voice alert (list items)	Not Available
	Other	Analog instrumentation Standard
	Fuel door lock (remote, key, electric)	Electric
Integrated Child Seating	Std/opt. & location in vehicle	
	Number of occupants	
	Occupant weight/height (min. & max.)	
	Restraint system description (3 or 5-point belts/booster seat capability)	
Lamps	Auto head on/off delay, dimming	Not Available
	Cornering	Not Available
	Courtesy (map, reading)	Standard - Floor, ISRVM
	Door lock, ignition	Not Available
	Engine compartment	Standard
	Fog	Optional
	Glove compartment	Standard - In Glove Box & I/P
	Trunk	Std. - Two Lamps Mounted in Rear Quarter
	Illuminated entry system (list lamps, activation)	Courtesy Lamps
	Other	Not Applicable
Mirrors	Day / night (auto., man.)	Standard, Manual
	L.H. (remote, power, heated)	Power Standard, Heated
	R.H. (convex, remote, power, heated)	Power Standard, Heated
	Visor vanity (RH / LH, illuminated)	Standard, Illuminated
	Navigation system (describe)	None
	Parking brake-auto release (warning light)	Manual Release, Tell-Tale-Standard

# MVMA Specifications

Vehicle Line CORVETTE  
 Model Year 1998 Issued \_\_\_\_\_ Revised (●) \_\_\_\_\_

## METRIC (U.S. Customary)

Model Code/Description

2-DOOR HATCHBACK COUPE 1YY07

Convertible 1YY67

### Convenience Equipment (standard, optional, n.a.)

Power equipment	Deck lid (release, pull down)		Standard - Electric Hatch Release (Two Remote Locations), I/P, Door Key
	Door locks (manual, automatic, describe system)		Standard Deck Lid Hatch Standard Door Locks
	Seats	2 - 4 - 6 way, etc.	Six-Way Optional
		Reclining (R.H., L.H.)	Manual Standard
		Memory (R.H., L.H., preset recline)	Optional
		Support (lumbar, hip, thigh, etc.)	Power Lumbar Optional
		Heated (R.H., L.H., other)	Not Available
	Side windows		Standard
	Vent windows		Not Available
	Rear windows		
Convertible Deck Lid		Standard - Power Release (2 Remote Locations) I/P & Door Key	
Radio systems	Antenna (location, w/rip, w/shield, power)		Windshield, Rear Glass or Power Antenna
	Standard	AM, FM, stereo, tape, compact disc, graphic equalizer, theft deterrent, radio prep package, headphone jacks, etc.	AM/FM Stereo Cassette / Bose
	Optional		AM/FM Stereo / Compact Disc / Bose Remote 12 Disc CD Changer in Rear Storage Well
	Speaker (number, location)		Bose - Four Front, Two Rear
Roof: open air or fixed (flip-up, sliding, *T*)			Single, Full Width Lift - Off Roof Panel Conv. Fldg. Top
Speed control device			Standard - Electronic Speed & Cruise Control W/Resume Feature
Speed warning device (light, buzzer, etc.)			Not Available
Tachometer (rpm)			7,000 W/LS1
Telephone system (describe)			Cellular Phone Power Connector under passenger foot floor
Theft deterrent system			"VATS" Pass Key (Personal Automobile Security System) Includes Special Module with Resistor Decoder and Ignition Key with Embedded Pellets of Specified Resistance. Built-In Time Lag. Forces Delay Between Attempts to Start Vehicle with Improper Key. Also Includes Anti-Theft Horn Alarm System with Starter Enable & Fuel (Doors and Hatch).

### Trailer Towing

(Not Applicable)

Towing capable	Yes / No	
Engine / transmission / axle	Std. / Opt.	
Tow class (I, II, III)*	Std. / Opt.	
Max. gross trailer wgt. (lbs.)	Std / Opt.	
Max. trailer tongue load (lbs.)	Std. / Opt.	
Towing package available	Yes / No	

\* Class I - 2,000 lbs. Class II - 3,500 lbs. Class III - 5,000 lbs.

# MVMA Specifications

Vehicle Line CORVETTE  
 Model Year 1998 issued \_\_\_\_\_ Revised (●) \_\_\_\_\_

## METRIC (U.S. Customary) Vehicle Dimensions

See Key Sheets for definitions

All dimensions to ground are for comparative purposes only. Dimensions are to be shown for all base body models of each vehicle line. SAE Ref. no. refers to the definition published in SAE Recommended Practice J1100 "Motor Vehicle Dimensions," unless otherwise specified.

Model Code/Description

SAE  
 Ref.  
 No.

COUPE

### Width

Tread (front)	W101	1575.6 (62.03)
Tread (rear)	W102	1578.4 (64.4)
Vehicle width	W103	1869.6 (73.6)
Body width at SgRP (front)	W117	1853.2 (72.9)
Vehicle width (front doors open)	W120	3979.84 (156.7)
Vehicle width (rear doors open)	W121	--
Tumble-home (degrees)	W122	31.3
Outside mirror width	W410	2080.9 (81.93)

### Length

Wheelbase	L101	2655.5 (104.5)
Vehicle length	L103	4565.6 (179.7)
Overhang (front)	L104	987.6 (38.8)
Overhang (rear)	L105	908.5 (35.8)
Upper structure length	L123	2696.7 (106.2)
Rear Wheel C/L "X" coordinate	L127	4073 (160)

### Height \*\*

Passenger distribution (front/rear)	PD1 2,3	PD1 = Front, PD2, 3NA
Trunk/cargo load		--
Vehicle height	H101	1211.3 (47.7)
Cowl point to ground	H114	815.1 (32.1)
Deck point to ground	H138	948.5 (37.3)
Rocker panel-front to ground	H112	128.0 (5.0)
Rocker panel-rear to ground	H111	131.3 (5.2)
Windshield slope angle (degrees)	H122	63.9
Backlight slope angle (degrees)	H121	75.3

### Ground Clearance \*\*

Front bumper to ground	H102	92.8 (3.7)
Rear bumper to ground	H104	343.6 (13.5)
Bumper to ground front at curb mass (wt.)	H103	106.9 (4.2)
Bumper to ground rear at curb mass (wt.)	H105	361.7 (14.2)
Angle of approach (degrees)	H106	8.82
Angle of departure (degrees)	H107	19.14
Ramp breakover angle (degrees)	H147	10.96
Axle differential to ground (front/rear)	H153	111.7 (4.4)
Min. running ground clearance	H156	36.7 (1.44)
Location of min. running ground clear.		Oil Drain Plug

\*\* All Vehicle Height And Ground Clearance Are Made Using EPA Loaded Vehicle Weight, Loading Conditions. EPA loaded vehicle weight is the base vehicle weight plus all coolant and fluids necessary for operation plus 100% of the fuel capacity, plus the weight of all options and accessories which weigh three pounds or more and which are sold on at least 33% of the car line, plus two occupants.

All linear dimensions are in millimeters (inches).

# MVMA Specifications

Vehicle Line CORVETTE  
 Model Year 1998 issued \_\_\_\_\_ Revised (●) \_\_\_\_\_

## METRIC (U.S. Customary)

### Vehicle Dimensions

See Key Sheets for definitions

#### Model Code/Description

SAE  
Ref.  
No.

2-DOOR HATCHBACK COUPE 1YY07

#### Front Compartment

SgRP front, "X" coordinate	L31	3138.4 (124)
Effective head room	H61	961.9 (37.8)
Max. effective leg room (accelerator)	L34	1085.8 (42.7)
SgRP to heel point	H30	187.2 (7.4)
SgRP to heel point	L53	900.8 (35.5)
Back angle (degrees)	L40	24.5
Hip angle (degrees)	L42	94.7
Knee angle (degrees)	L44	130.5
Foot angle (degrees)	L46	87.0
Design H-point front travel	L17	205.7 (8.1)
Normal driving & riding seat track trvl.	L23	188.8 (7.4)
Shoulder room	W3	1405.4 (55.3)
Hip room	W5	1377.8 (54.2)
Upper body opening to ground	H50	1111.2 (43.7)
Steering wheel maximum diameter*	W9	381.5 (15)
Steering wheel angle (degrees)	H18	16.4
Accel. heel pt. to steer. whl. cntr.	L11	558.7 (22.0)
Accel. heel pt. to steer. whl. cntr.	H17	396.5 (15.6)
Undepressed floor covering thickness	H67	16.0 (0.63)

Front Compartment Interior Dimensions are Measured with the Seating Reference Point (SgRP) \_\_\_\_\_ mm forward and \_\_\_\_\_ mm Upward of Rearmost Position.

#### Rear Compartment

SgRP point couple distance	L50	
Effective head room	H83	
Min. effective leg room	L51	
SgRP (second to heel)	H31	
Knee clearance	L48	
Shoulder room	W4	
Hip room	W6	
Upper body opening to ground	H51	
Back angle (degrees)	L41	
Hip angle (degrees)	L43	
Knee angle (degrees)	L45	
Foot angle (degrees)	L47	
Depressed floor covering thickness	H73	

#### Luggage Compartment

Usable luggage capacity L (cu. ft.)	V1	Not Applicable
Liftover height	H195	935.2 (36.8)

#### Interior Volumes (EPA Classification)

Vehicle class		Mini-Compact
Interior volume index including trunk/cargo (cu. ft.)**	E1	Not Applicable
Trunk/cargo index (cu. ft.)	V13	Not Applicable

\* See page 14.

\*\* See definition page 33.

All linear dimensions are in millimeters (inches) unless otherwise noted.

\*\*\* EPA Loaded Vehicle Weight, Loading Conditions

# MVMA Specifications

Vehicle Line CORVETTE  
 Model Year 1998 issued            Revised (●)           

## METRIC (U.S. Customary) Vehicle Dimensions

See Key Sheets for definitions

Model Code/Description

2-DOOR HATCHBACK COUPE 1YY07

Station Wagon/MPV\*  
 -Third Seat

SAE  
 Ref.  
 No. NOT APPLICABLE)

Seat facing direction	SD1	
SgRP couple distance	L85	
Shoulder room	W85	
Hip room	W86	
Effective leg room	L86	
Effective head room	H86	
SgRP to heel point	H87	
Knee clearance	L87	
Back angle (degrees)	L88	
Hip angle (degrees)	L89	
Knee angle (degrees)	L90	
Foot angle (degrees)	L91	

### Station Wagon/MPV\* - Cargo Space (NOT APPLICABLE)

Cargo length (open front)	L200	
Cargo length (open second)	L201	
Cargo length (closed front)	L202	
Cargo length (closed second)	L203	
Cargo length at belt (front)	L204	
Cargo length at belt (second)	L205	
Cargo width (wheelhouse)	W201	
Rear opening width at floor	W203	
Opening width at belt	W204	
Min. rear opening width above belt	W205	
Cargo height	H201	
Rear opening height	H202	
Tailgate to ground height	H250	
Front seat back to load floor height	H197	
Cargo volume index m <sup>3</sup> (ft. <sup>3</sup> )	V2	
Hidden cargo volume index m <sup>3</sup> (ft. <sup>3</sup> )	V4	
Cargo volume index-rear of 2-seat	V10	
Cargo volume index*	V8	
Cargo width at floor*	W500	
Maximum cargo height*	H505	

### Hatchback - Cargo Space

Cargo length at front seatback height	L208	1242.4 (48.9)
Cargo length at floor (front)	L209	1305.5 (51.4)
Cargo length at second seatback height	L210	Not Applicable
Cargo length at floor (second)	L211	Not Applicable
Front seatback to load floor height	H197	471.7 (18.6)
Second seatback to load floor height	H198	Not Applicable
Cargo volume index m <sup>3</sup> (ft. <sup>3</sup> )	V3	0.701 m <sup>3</sup> (24.75)
Hidden cargo volume index m <sup>3</sup> (ft. <sup>3</sup> )	V4	Not Applicable
Cargo volume index - rear of 2-seat	V11	Not Applicable

All linear dimensions are in millimeters (inches) unless otherwise noted.  
 \* MPV - Multipurpose Vehicle  
 \*\* EPA Loaded Vehicle Weight, Loading Conditions

# MVMA Specifications

Vehicle Line CORVETTE  
 Model Year 1998 Issued \_\_\_\_\_ Revised (●) \_\_\_\_\_

## METRIC (U.S. Customary)

Model Code/  
Description

2-DOOR HATCHBACK COUPE 1YY07

### Vehicle Fiducial Marks

Fiducial Mark Number*	Define Coordinate Location	
Front	<p>X - Fiducial mark to vertical zero grid line - front measured horizontally, from the zero grid line to the front fiducial mark located on top of the front seat adjuster mounting bolt.</p> <p>Y - Fiducial mark to centerline of car - front, width measurement made from centerline car to fiducial mark located on top of the front seat adjuster mounting bolt.</p> <p>Z - Fiducial mark to horizontal zero grid line - front, measured vertically from zero grid line to front fiducial mark located on top of the front seat adjuster mounting bolt.</p>	
Rear	<p>X - Fiducial mark to vertical zero grid line - rear, measured horizontally from the zero grid line to rear fiducial mark located on the rail (compartment pan - longitudinal.)</p> <p>Y - Fiducial mark to centerline of car - rear, width measurement made from centerline of car to fiducial mark located on the rail (compartment pan - longitudinal.)</p> <p>Z - Fiducial mark to horizontal zero grid line - rear, measured vertically from the zero grid line to rear fiducial mark located on the rail (compartment pan - longitudinal.)</p>	
NOTE: Provide 3 of 4 Fiducial Mark Locations		
Front	W21**	-555.0 (-21.8)
	L54**	2715.0 (106.8)
	H81**	364.3 (14.3)
	H161**	187.5 (7.4)
	H163**	169.7 (6.7)
Rear	W22**	Not Applicable
	L55**	Not Applicable
	H82**	Not Applicable
	H162**	Not Applicable
	H164**	Not Applicable

\* Reference - SAE Recommended Practice, J182a, Motor Vehicle Fiducial Marks.

\*\* Reference - SAE Recommended Practice J1100 - Motor Vehicle Dimensions.

\*\*\* EPA Loaded Vehicle Weight, Loading Conditions

All linear dimensions are in millimeters (inches) unless otherwise noted.



**MVMA Specifications  
METRIC (U.S. Customary)**

Vehicle Line CORVETTE  
Model Year 1998 Issued \_\_\_\_\_ Revised (●) \_\_\_\_\_

Code	Model	VEHICLE MASS (WEIGHT)				ETWC** Code	% PASS MASS DISTRIBUTION			
		CURB MASS. kg. (lb.)*			Shipping Mass kg (lb)***		Pass in Front		Pass in Rear	
		Front	Rear	Total			Front	Rear	Front	Rear
1YY07		772	728	1500	1452	V	30.0	70.0	-	-
	2-DOOR COUPE (LS1 & M30)	(1702)	(1605)	(3307)	(3201)					

\* Reference - SAE J1100 Motor vehicle dimensions, curb weight definition.  
\*\* ETWC - Equivalent Test Weight Class - basis for U.S. Environmental Protection Agency emission certifications.  
Refer to ETWC code legend below for test weight class.

- |          |          |          |           |
|----------|----------|----------|-----------|
| A = 1000 | I = 2000 | Q = 3000 | Y = 4000  |
| B = 1125 | J = 2125 | R = 3125 | Z = 4250  |
| C = 1250 | K = 2250 | S = 3250 | AA = 4500 |
| D = 1375 | L = 2375 | T = 3375 | BB = 4750 |
| E = 1500 | M = 2500 | U = 3500 | CC = 5000 |
| F = 1625 | N = 2625 | V = 3625 | DD = 5250 |
| G = 1750 | O = 2750 | W = 3750 | EE = 5500 |
| H = 1875 | P = 2875 | X = 3875 | FF = 5750 |

\*\*\* Shipping Mass (weight) = Curb Weight Less:  
48 (106)

---



---



---

**MVMA Specifications**  
**METRIC (U.S. Customary)**

Vehicle Line CORVETTE  
Model Year 1998      Issued \_\_\_\_\_      Revised (●) \_\_\_\_\_

		Optional Equipment Differential Mass (weight)*			
Code	Equipment	MASS, kg. (lb.)			Remarks Restrictions, Requirements
		Front	Rear	Total	
AQ9	Custom Adjustable Seats	1.4 (3.0)	3.4 (7.5)	4.8 (10.5)	Power Adjust for Backrest Lateral Restrains, Lumbar Support and Back
B16	Leather Seat Trim	.6 (1.3)	1.0 (2.2)	1.6 (3.5)	As Required (Special Contour Bucket Seat)
CC3	Removable Plastic Roof Panel	-0.6 (-1.3)	-1.4 (-3.1)	-2.0 (-4.4)	Acrylic Plastic, Lighter, Blue Tinted for Glare and Sun Load Control, Coated for Scratch Resistance. N/A. on Convertible
CJ2	Automatic Electronic Dual Zone Climate Control	1.0 (2.2)	--	1.0 (2.2)	Automatic Temperature Control
DL8	Mirror O/S LH & RH, Remote Control Elec. Heated				
ML9	Manual Transmission	-10.8 (-23.8)	-8.8 (-19.4)	-19.6 (-43.2)	
UU8	Daphi/Bose	1.4	2.4	3.8	Includes Specific AM/FM Stereo Radio
UX0	Premium Audio System	(3.0)	(5.3)	(8.3)	w/Cassette Player, Bose Power Amplified, Direct Reflecting Speakers (One in Each Door and at Each Side of Luggage Area). Also Features Dolby Sound, Dynamic Noise Reduction and Automatic Suppression Sys.
Z07	Bilstein Selective Ride Control System; Stiffer Springs, Shocks, Stabilizer Bars & Bushings. Heavy Duty Brakes, Engine Oil Cooler, Heavy Duty Power Steering Cooler.	8.4 (18.4)	2.6 (5.8)	11.0 (24.2)	(1YY07 Only; Auto Trans. Requires G92 Axle)

\* Also see Engine - General Section for dressed engine mass (weight.)

# Specifications METRIC

## Exterior Vehicle And Body Dimensions - Key Sheet

Exterior Width Dimensions

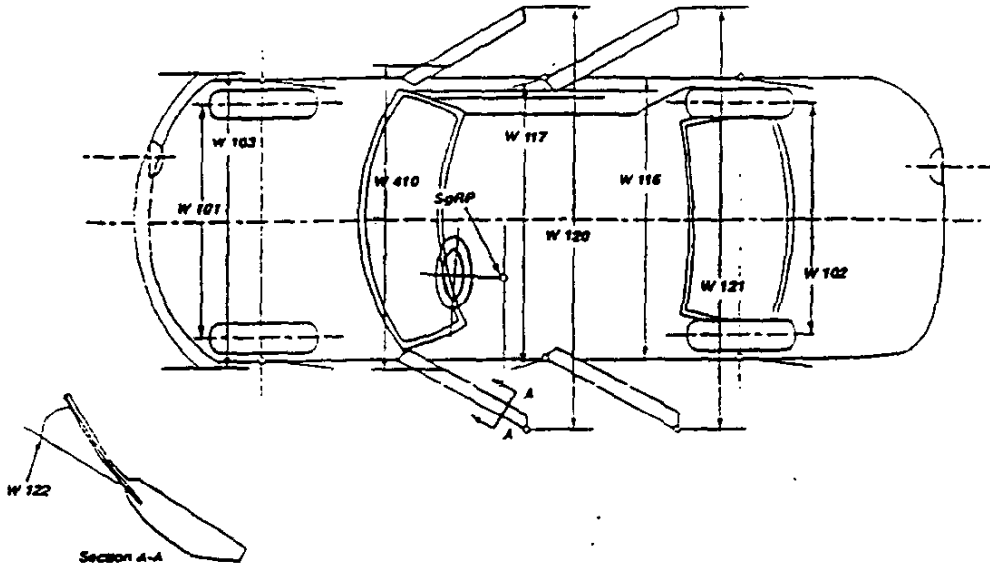

Exterior Length & Height Dimensions

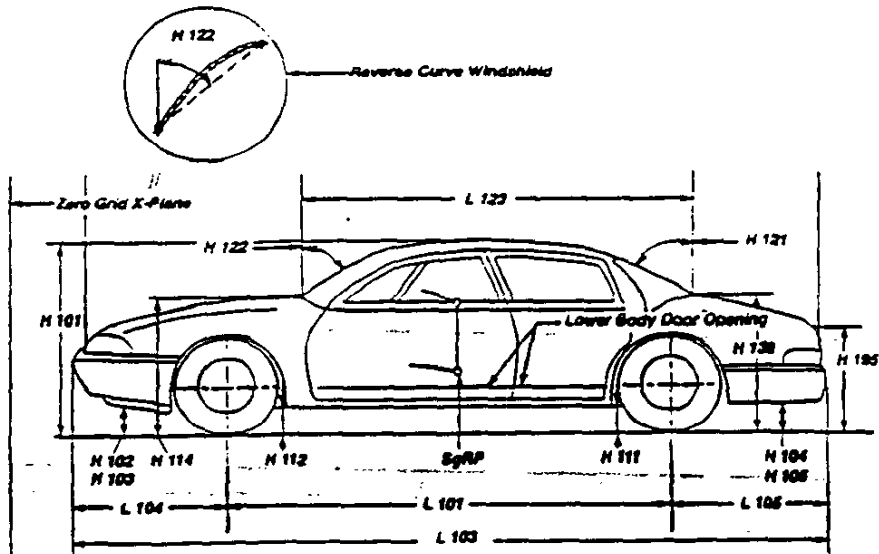

Ground Clearance Dimensions

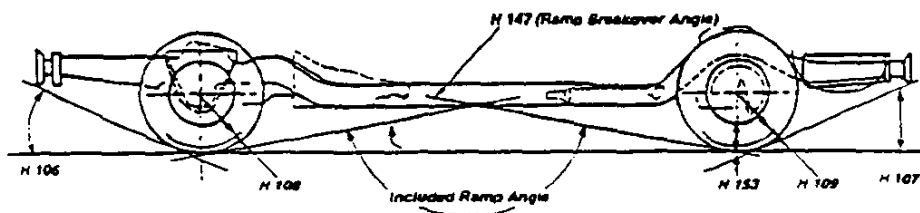

# Specifications

## METRIC

### Interior Vehicle And Body Dimensions - Key Sheet

Interior Length Dimensions

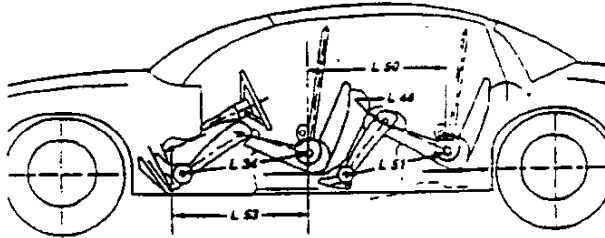

Interior Height Dimensions

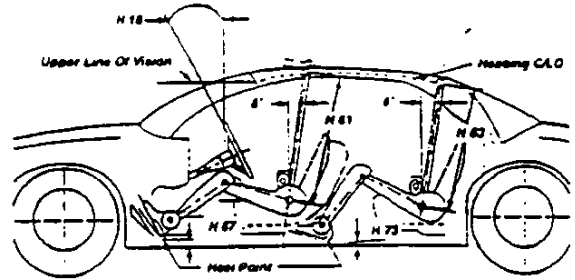

Interior Height Dimensions

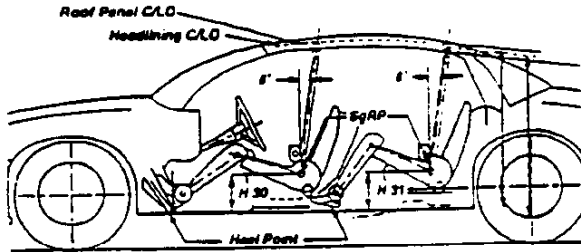

Interior Length Dimensions

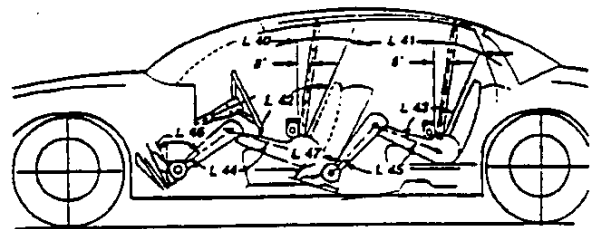

Interior Width Dimensions

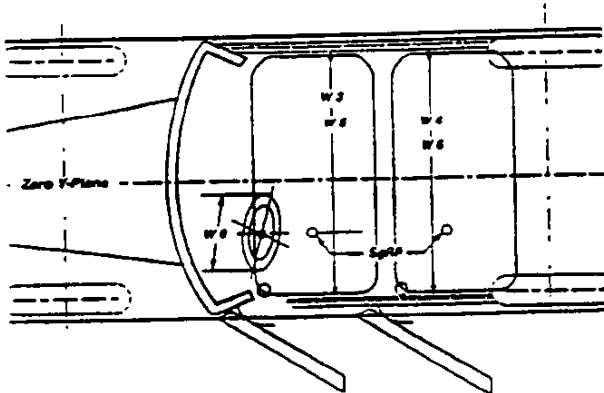

Interior Height Dimensions

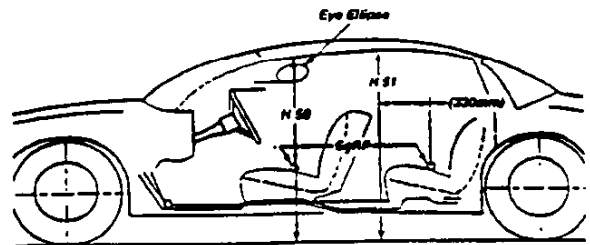

# Specifications METRIC

## Interior Vehicle And Body Dimensions - Key Sheet

Interior Dimensions, Station Wagon Third Seat

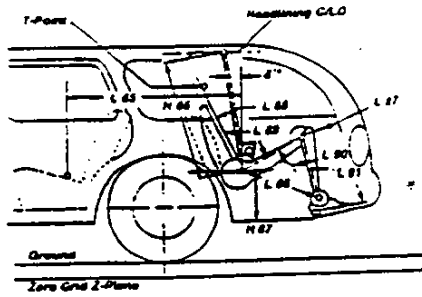

Interior Dimensions

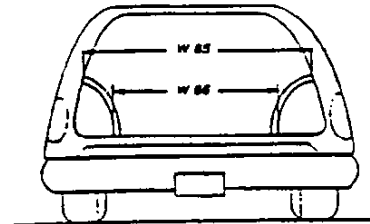

Cargo Space Dimensions

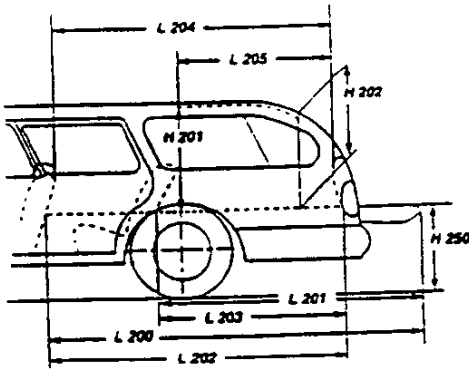

Cargo Space Dimensions

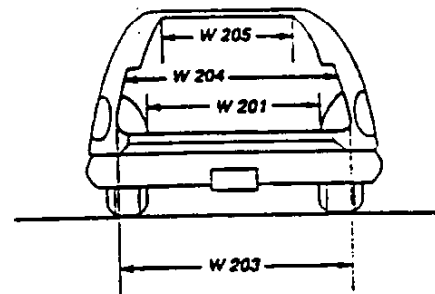

Cargo Space Dimensions

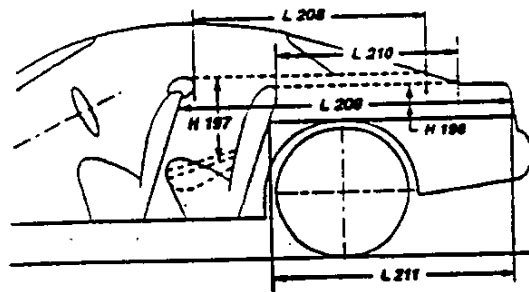

Multipurpose Vehicle Cargo Space

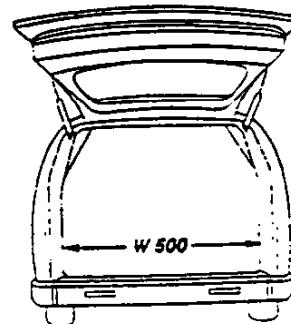
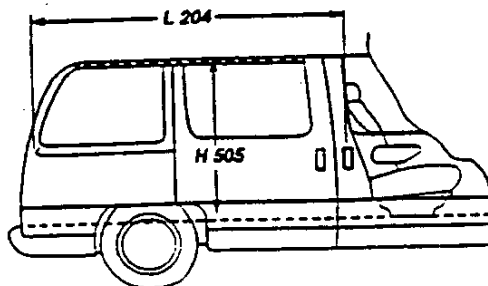

# Specifications

## METRIC

### Exterior Vehicle And Body Dimensions - Key Sheet Dimensions Definitions

#### Seating Reference Point

SEATING REFERENCE POINT means the manufacturer's design reference point which -

- (a) Establishes the rearmost normal design driving or riding position of each designated seating position in a vehicle;
- (b) Has coordinates established relative to the design vehicle structure;
- (c) Simulates the position of the pivot center of the human torso and thigh; and
- (d) is the reference point employed to position the two dimensional templates described in SAE Recommended Practice J826, "Devices for Use in Defining and Measuring Vehicle Seating Accommodations."

#### Width Dimensions

- W101 TREAD-FRONT. The dimension measured between the tire centerlines at the ground.
- W102 TREAD-REAR. The dimension measured between the tire centerlines at the ground. In case of dual wheels, the dimension will be measured to the centerline of the inner and wheel assemblies.
- W103 VEHICLE WIDTH. The maximum dimension measured between the widest point on the vehicle, excluding exterior mirrors, flexible mud flaps, marker lamps, but including bumpers, moldings, sheet metal protrusions or dual wheels, if standard equipment.
- W117 BODY WIDTH AT SgRP-FRONT. The dimension measured laterally between the widest points on the body at the SgRP-front, excluding door handles, applied moldings, or appliques.
- W120 VEHICLE WIDTH-FRONT DOORS OPEN. The dimension measured between the widest point on the rear doors in maximum hold-open position.
- W121 VEHICLE WIDTH-REAR DOORS OPEN. The dimension measured between the widest point on the rear doors in maximum hold-open position. For vehicles with a rear door on only one side, this dimension is to the zero "Y" plane.
- W122 TUMBLE-HOME, STRAIGHT SIDE GLASS. The angle measured from a vertical to the outside surface of the front door glass at the SgRP "X" plane;  
CURVED SIDE GLASS. The angle measured from a vertical to a chord extending from the upper DLO to the lower DLO at the outside surface of the front door glass at the front SgRP "X" plane.
- W410 OUTSIDE MIRROR WIDTH: The dimension between the widest point on the outside mirrors. The standard right and left mirror adjusted for normal driving will be shown unless otherwise noted. When only one outside mirror is standard, the dimension will be to the zero "Y" plane.

#### Length Dimensions

- L101 WHEELBASE (WB). The dimension measured longitudinally between front and rear-wheel centerline. In case of dual rear axles, the dimension shall be to the midpoint of the centerlines of the rear wheels.
- L103 VEHICLE LENGTH. The maximum dimension measured longitudinally between the foremost point and the rearmost point on the vehicle, including bumper, bumper guards, tow hooks and/or rub strips, if standard equipment.
- L104 OVERHANG-FRONT. The dimension measured longitudinally from the centerline of the front wheels to the foremost point on the vehicle including bumper, bumper guards, tow hook and/or rub strips, if standard equipment.
- L105 OVERHANG-REAR. The dimension measured longitudinally from the centerline of the rear wheels; or in the case of dual rear axles, the dimension shall be the midpoint of the centerlines of the rear wheels, to the rearmost point on the vehicle including rear bumpers, bumper guards, tow hooks and rub strips, if standard equipment.

- L123 UPPER STRUCTURE LENGTH. The dimension measured longitudinally from the cowl point to the deck point.
- L127 REAR WHEEL CENTERLINE "X" COORDINATE or in the case of dual rear axles, the coordinate shall be the midpoint of the distance between the rear axle centerlines.

#### Height Dimensions

- H101 VEHICLE HEIGHT. The dimension measured vertically from the highest point on the vehicle body to ground.
- H111 ROCKER PANEL-REAR TO GROUND. The dimension measured vertically from the bottom of the rocker or side quarter panel at the front of the rear wheel opening, excluding flanges, to ground.
- H112 ROCKER PANEL-FRONT TO GROUND. The dimension measured vertically from the foremost point on the bottom of the rocker panels, excluding flanges, to ground.
- H114 COWL POINT TO GROUND. Measured at zero "Y" plane.
- H121 BACKLIGHT SLOPE ANGLE. The angle between the vertical reference line and the surface of backlight at vehicle zero "Y" plane. For curve backlight, the angle is to chord of backlight arc from lower DLO to upper DLO.
- H122 WINDSHIELD SLOPE ANGLE. The angle between the vertical reference line and a chord of the windshield arc running from the lower DLO to the upper DLO at the vehicle zero "Y" plane. In the case of wrap over glass, the angle to be measured will be formed by a chord 457 mm (18.0 in.) long drawn from the lower DLO to the intersecting point on the windshield.
- H138 DECK POINT TO GROUND. Measured at zero "Y" plane.
- H109 STATICLOAD-TIRE RADIUS-REAR. Specified by the manufacturer in accordance with composite TIRE SECTION STANDARD.

#### Ground Clearance Dimensions

- H102 FRONT BUMPER TO GROUND. The minimum dimension measured vertically from the lowest point on the front bumper to ground, including bumper guards, if standard equipment.
- H103 FRONT BUMPER TO GROUND-CURBMASS(WT.). Measured in the same manner as H102.
- H104 REAR BUMPER TO GROUND. The minimum dimension measured vertically from the lowest point on the rear bumper to ground, including bumper guards, if standard equipment.
- H105 REAR BUMPER TO GROUND-CURBMASS(WT.). Measured in the same manner as H104.
- H106 ANGLE OF APPROACH. The angle measured between a line tangent to the front tire static loaded radius arc and the initial point of structural interference forward of the front tire to ground. The limiting structural component shall be designated.
- H107 ANGLE OF DEPARTURE. The angle measured between a line tangent to the rear tire static loaded radius arc and the initial point of structural interference rearward of the rear tire to ground. The limiting component shall be designated.
- H147 RAMP BREAKOVER ANGLE. The angle measured between two lines tangent to the front and rear tire static loaded radius and intersecting at a point on the underside of the vehicle which defines the largest ramp over which the vehicle can roll.
- H153 REAR AXLE DIFFERENTIAL TO GROUND. The minimum dimension measured from the rear axle differential to ground.
- H156 MINIMUM RUNNING GROUND CLEARANCE. The minimum dimension measured from the sprung vehicle to ground. Specify location.

# Specifications

## METRIC

### Interior Vehicle And Body Dimensions - Key Sheet

#### Dimensions Definitions

##### Glass Areas

- S1 Windshield area.
- S2 Side windows area. Includes the front door, rear door, vents, and rear quarter windows on both sides of the vehicle.
- S3 Backlight areas.
- S4 Total area. Total of all areas (S1 + S2 + S3).

##### Fiducial Mark Dimensions

- Fiducial Mark - Number 1**
- L54 "X" coordinate.
- W21 "Y" coordinate.
- H81 "Z" coordinate.
- H161 Height "Z" coordinate to ground at curb weight.
- H163 Height "Z" coordinate to ground.
- Fiducial Mark - Number 2**
- L55 "X" coordinate.
- W22 "Y" coordinate.
- H82 "Z" coordinate.
- H162 Height "Z" coordinate to ground at curb weight.
- H164 Height "Z" coordinate to ground.

##### Front Compartment Dimensions

- L11 ACCELERATOR WHEEL POINT TO STEERING WHEEL CENTER. The dimension measured horizontally from the AHP to the intersection of the steering column centerline and a plane tangent to the upper surface of the steering wheel rim.
- L17 DESIGN-H-POINT-FRONT TRAVEL. The dimension measured horizontally between the design H-point-front in the foremost and rearmost seat track positions. (See SAE J1100)
- L23 NORMAL DRIVING AND RIDING SEAT TRACK TRAVEL. The dimension measured horizontally between a point on the design H-point travel line from the SgRP to the displaced point on the design H-point travel line with the seat moved to the foremost seat position, but not to include seat track travel used for purposes other than normal driving and riding positions. (See SAE J1100).
- L31 SgRP-Front, "X" Coordinated.
- L34 MAXIMUM EFFECTIVE LEG ROOM-ACCELERATOR. The dimension measured along a line from the ankle pivot center to the SgRP-front plus 254 mm (10.0 in.) measured with right foot on the underdepressed accelerator pedal. For vehicles with SgRP to heel (H30) greater than 18 in., the accelerator pedal may be depressed as specified by the manufacturer. If the accelerator is depressed, the manufacturer shall place foot flat on pedal and note the depression of the pedal.
- L40 BACK ANGLE-FRONT. The angle measured between a vertical line through the SgRP-front and the torso line. If the seatback is adjustable, use the normal driving and riding position specified by the manufacturer.
- L42 HIP ANGLE-FRONT. The angle measured between torso line and thigh centerline.
- L44 KNEE ANGLE-FRONT. The angle measured between thigh centerline and lower leg centerline measured on the right leg.
- L46 FOOT ANGLE-FRONT. The angle measured between the lower leg centerline and a line tangent to the ball and heel of the bare foot flesh line measured on the right leg. Ref SAE J826.
- L53 SgRP-FRONT TO HEEL. The dimension measured horizontally from the SgRP-front to the accelerator heel point.
- W3 SHOULDER ROOM-FRONT. The minimum dimension measured laterally between the trimmed surfaces on the "X" plane through the SgRP-front at height between the belt line and 254 mm (10.0 in.) above the SgRP-front, excluding the door assist strap and attaching parts.

- W5 HIP ROOM-FRONT. The minimum dimension measured laterally between the trimmed surfaces of the "X" plane through the SgRP-front within 25 mm (1.0 in.) below and 76 mm (3.0 in.) above the SgRP-front and 76 mm (3.0 in.) fore and aft of the SgRP-front.
- W9 STEERING WHEEL MAXIMUM OUTSIDE DIAMETER. Define if other than round.
- H7 ACCELERATOR HEEL POINT TO THE STEERING WHEEL CENTER. The dimension measured vertically from the AHP-front to the intersection of the steering column centerline to a plane tangent to the upper surface of the steering wheel rim.
- H18 STEERING WHEEL ANGLE. The angle measured from a vertical to the surface plane of the steering wheel.
- H30 SgRP-FRONT TO HEEL. The dimension measured vertically from the SgRP-front to the accelerator heel point.
- H50 UPPER BODY OPENING TO GROUND-FRONT. The dimension measured vertically from the trimmed body opening to the ground on the SgRP-front "X" plane.
- H61 EFFECTIVE HEAD ROOM-FRONT. The dimension measured along a line 8 deg. rear of vertical from the SgRP-front to the headlining plus 102 mm (4.0 in.).
- H67 FLOOR COVERING THICKNESS - UNDEPRESSED - FRONT. The dimension measured vertically from the surface of the underdepressed floor covering to the underbody sheet metal at the accelerator heel point.

##### Rear Compartment Dimensions

- L41 BACK ANGLE-SECOND. The angle measured between a vertical line through the SgRP-second and the torso line.
- L43 HIP ANGLE-SECOND. The angle measured between torso line and thigh centerline.
- L45 KNEE ANGLE-SECOND. The angle measured between thigh centerline and lower leg centerline.
- L47 FOOT ANGLE-SECOND. The angle measured between the lower leg centerline and a line tangent to the ball and heel of the three-dimensional devices bare foot flesh line (Reference J826).
- L48 KNEE CLEARANCE-SECOND. The minimum dimension measured from the knee pivot center to the back of the front seatback minus 51 mm (2.0 in.).
- L50 SgRP COUPLE DISTANCE-SECOND. The dimension measured horizontally from the driver SgRP-front to the SgRP-second.
- L51 MINIMUM EFFECTIVE LEG ROOM-SECOND. The dimension measured along a line from the ankle pivot center to the SgRP-second plus 254 mm (10.0 in.).
- W4 SHOULDER ROOM-SECOND. The minimum dimension measured laterally between door or quarter trimmed surfaces on the "X" plane through the SgRP-second at height between 254-406 mm (10.0-16.0 in.) above the SgRP-second, excluding the door assist straps and attaching parts.
- W6 HIP ROOM-SECOND. Measured in the same manner as W5.
- H31 SgRP-SECOND TO HEEL. The dimension measured vertically from the SgRP-second to the two dimensional device heel point on the depressed floor covering.
- H51 UPPER BODY OPENING TO GROUND-SECOND. The dimension measured vertically from the trimmed body opening to the ground on the "X" plane 330 mm (13.0 in.) forward of the SgRP-second.
- H63 EFFECTIVE HEAD ROOM-SECOND. The dimension measured along a line 8 deg. rear of vertical from the SgRP to the headlining, plus 102 mm (4.0 in.).
- H73 FLOOR COVERING-DEPRESSED-SECOND. The dimension measured vertically from the heel point to the underbody sheet metal.

# Specifications

## METRIC

### Interior Vehicle And Body Dimensions - Key Sheet Dimensions Definitions

#### Luggage Compartment Dimensions

V1 USABLE LUGGAGE CAPACITY-Total of volumes of individual pieces of standard luggage set plus H-boxes stowed in the luggage compartment in accordance with the procedure described in paragraph 8.2 of SAE-J1100a.

#### Interior Volumes (EPA Classification)

The interior index is listed for each body style except two seaters. The interior Volume Index estimates the space in a car. It is based on four measurements - head room, shoulder room, hip room, and leg room - for the front and rear seats, plus trunk capacity.

The Trunk/Cargo Index is an estimate of the size of the trunk/cargo space. In station wagons and hatchbacks it is an estimate of the space behind the second seat.

#### Station Wagon/MPV - Third Seat Dimensions

- L85 SgRP COUPLE DISTANCE-THIRD. The dimension measured horizontally from the SgRP-second to the SgRP-third.
- L86 EFFECTIVE LEG ROOM-THIRD. The dimension measured along a line from the ankle pivot center to the SgRP-third plus 254 mm (10.0 in).
- L87 KNEE CLEARANCE-THIRD. The minimum dimension from the knee pivot center to the back of second seatback minus a constant of 51 mm (2.0in.). With rear-facing third seat, dimension is measured to closure.
- L88 BACK ANGLE-THIRD. Measured in the same manner as L41.
- L89 HIP ANGLE-THIRD. Measured in the same manner as L43.
- L90 KNEE ANGLE-THIRD. Measured in the same manner as L45.
- L91 FOOT ANGLE-THIRD. Measured in the same manner as L47.
- W85 SHOULDER ROOM-THIRD. Measured in the same manner as W4.
- W86 HIP ROOM-THIRD. Measured in the same manner as W5.
- H86 EFFECTIVE HEAD ROOM-THIRD. The dimension, measured along a line 8 deg. from the SgRP-third to the headlining rear of vertical plus a constant of 102 mm (4.0 in.).
- H87 SgRP-THIRD TO HEEL POINT
- SD1 SEAT FACING DIRECTION-THIRD.

#### Station Wagon/MPV - Cargo Space Dimensions

- L200 CARGO LENGTH-OPEN-FRONT. The minimum dimension measured longitudinally from the back of the front seatback at the height of the undepressed floor covering to the rearmost point on the undepressed floor covering on the open tailgate or cargo surface if the rear closure is a conventional door type tailgate at the zero "Y" plane.
- L201 CARGO LENGTH-OPEN-SECOND. The dimension measured longitudinally from the back of the second seatback at the height of the undepressed floor covering on the open tailgate or cargo floor surface if the rear closure is a conventional door type tailgate, at the zero "Y" plane.

- L202 CARGO LENGTH-CLOSED-FRONT. The minimum dimension measured horizontally from the back of the front seat at the height of the undepressed floor covering to the rearmost point on the undepressed floor covering on the closed tailgate or taildoor for station wagons, trucks and mpv's at the zero "Y" plane.
- L203 CARGO LENGTH-CLOSED-SECOND. The dimension measured horizontally from the back of the second seat at the height of the undepressed floor covering to the rearmost point on the undepressed floor covering on the closed tailgate or taildoor for station wagons, trucks and mpv's at the zero "Y" plane.
- L204 CARGO LENGTH AT BELT-FRONT. The minimum dimension measured horizontally from the back of the front seatback at the seatback top to the foremost normal surface of the closed tailgate or inside surface of the cab backpanel at the height of the belt, on the zero "Y" plane.
- L205 CARGO LENGTH AT BELT-SECOND. The minimum dimension measured horizontally from the back of the second seatback top to the foremost normal surface of the closed tailgate at the height of the belt, on the zero "Y" plane.
- W201 CARGO WIDTH-WHEELHOUSE. The minimum dimension measured laterally between the trimmed wheelhousings at floor level. For any vehicle not trimmed, measure to the sheet metal.
- W203 REAR OPENING WIDTH AT FLOOR. The minimum dimension measured laterally between the limiting interferences of the rear opening at floor level.
- W204 REAR OPENING WIDTH AT BELT. The minimum dimension measured laterally between the limiting interferences of the rear opening at belt height or top of pick up box.
- W205 REAR OPENING WIDTH ABOVE BELT. The minimum dimension measured laterally between the limiting interferences of the rear opening above the belt height.
- W500 CARGO WIDTH AT FLOOR. The maximum dimension measured laterally between the limiting interferences at the floor level. This dimension shall include ribs and pillars, but will exclude wheelhouses.
- H197 FRONT SEATBACK TO LOAD FLOOR HEIGHT. The dimension measured vertically from the horizontal tangent to the top of the seatback to the undepressed floor covering.
- H201 CARGO HEIGHT. The dimension measured vertically from the top of the undepressed floor covering to the headlining at the rear wheel "X" coordinate on the zero "Y" plane.
- H202 REAR OPENING HEIGHT. The dimension measured vertically from the top of the undepressed floor covering to the upper trimmed opening on the zero "Y" plane with rear door fully open.
- H250 TAILGATE TO GROUND CURB MASS (WT.) The dimension measured vertically from the top of the undepressed floor covering on the lowered tailgate to ground on the zero "Y" plane.
- H505 MAXIMUM CARGO HEIGHT. The maximum vertical dimension rear of the front seat from the cargo floor to roof bow or headlining at the zero "Y" plane.



# Specifications

## METRIC

### Interior Vehicle And Body Dimensions - Key Sheet

#### Dimensions Definitions

<p>V2 STATION WAGON Measured in inches:</p> $\frac{W4 \times H201 \times L204}{1728} - ft^3$ <p>Measured in mm:</p> $\frac{W4 \times H201 \times L204}{10^9} - m^3(cubicmeter)$	<p>L208 CARGO LENGTH AT FRONT SEATBACK HEIGHT. The minimum horizontal dimension from the "X" plane tangent to the rearmost surface of the driver's seatback to the inside limiting interference of the hatchback door on the vehicle zero "Y" plane.</p> <p>L209 CARGO LENGTH AT FLOOR-FRONT. The minimum horizontal dimension measured at floor level from the rear of the front seatback to the normal limiting interference of the hatchback door on the vehicle zero "Y" plane.</p> <p>L210 CARGO LENGTH AT SECOND SEATBACK HEIGHT. The minimum dimension measured from the "X" plane tangent to the rearmost surface of second seatback or the load floor which is towed at least one half of the H198 dimension height above the rear load floor, to the rearmost inside limiting interference on the zero "X" plane.</p> <p>L211 CARGO LENGTH AT FLOOR-SECOND SEATBACK. The minimum horizontal dimension measured at floor level from the rear of the second seatback or load floor panel to the normal limiting interference of the hatchback door on the vehicle zero "Y" plane.</p> <p>H197 FRONT SEATBACK TO LOAD HEIGHT. The dimension measured vertically from the horizontal tangent to the top of the seatback to the undepressed floor covering.</p> <p>H198 SECOND SEATBACK TO LOAD FLOOR HEIGHT. The dimension measured vertically from the second seatback to the undepressed floor covering.</p> <p>V3 HATCHBACK. Measured in inches:</p> $\frac{L208 - L209}{2} \times W4 \times H197 - ft^3$ <p>Measured in mm:</p> $\frac{L208 - L209}{2} \times W4 \times H197 - m^3(cubicmeter)$
<p>V4 HIDDEN LUGGAGE CAPACITY-REAR OF FRONT SEAT. The total volumes of individual pieces of one set of standard luggage stowed in any hidden cargo area below the load floor rear of the front seat.</p>	<p>V4 HIDDEN LUGGAGE CAPACITY-REAR OF FRONT SEAT. The total volumes of individual pieces of one set of standard luggage stowed in any hidden cargo area below the load floor rear of the front seat.</p>
<p>V5 TRUCKS AND MPV'S WITH OPEN AREA. Measured in inches:</p> $\frac{L506 \times W505 \times H503}{1728} - ft^3$ <p>Measured in mm:</p> $\frac{L506 \times W500 \times H503}{10^9} - m^3(cubicmeter)$	<p>V11 HATCHBACK CARGO VOLUME INDEX. Usable luggage (one (1) stand and luggage set) below floor: Measured in inches:</p> $\frac{L210 - L211}{2} \times W4 \times H198 - ft^3$ <p>Measured in mm:</p> $\frac{L210 - L211}{2} \times W4 \times H198 - m^3(cubicmeter)$
<p>V6 TRUCKS AND MPV'S WITH CLOSED AREA. Measured in inches:</p> $\frac{L204 \times W500 \times H505}{1728} - ft^3$ <p>Measured in mm:</p> $\frac{L204 \times W500 \times H505}{10^9} - m^3(cubicmeter)$	<p>V10 STATION WAGON CARGO VOLUME INDEX. Measured in inches:</p> $\frac{H201 \times L205 \times \frac{W4 - W201}{2}}{1728} - ft^3$ <p>Measured in mm:</p> $\frac{H201 \times L205 \times \frac{W4 - W201}{2}}{10^9} - m^3(cubicmeter)$

#### Hatchback - Cargo Space Dimensions

All Hatchback cargo dimensions are to be taken with the front seat in full down and rear position, and the rear seat folded down. The hatchback door is in the closed position. (For electronically adjusted seats, see the manufacturer's specifications for Design "H" Point).

# Specifications

## METRIC

### Index

Subject	Page No.	Subject	Page No.
Alternator	16	Origin	1
Axle, Drive, Front, Rear, All Four	2, 9, 10	Passenger Capacity	1
Axle Shafts	10	Passenger Mass Distribution	26
Battery	16	Pistons	3
Body and Miscellaneous Information	17	Power Brakes	12
Brakes-Parking Service	12, 13	Power Engine	2
Camber	15	Power Steering	14
Camshaft	3	Power Teams	2
Capacities		Propeller Shaft	10
Cooling System	5	Pumps-Fuel	6
Fuel Tank	6	Water	5
Lubricants		Radiator-Cap, Hoses, Core	5
Engine Crankcase	4	Ratios-Axle, Transaxle	2, 9, 10
Transmission/Transaxle	8, 9	Compression	2
Rear Axle	10	Steering	14
Carburetor	2, 6	Transmission/Transaxle	2, 8, 9
Caster	1, 15	Rear Axle	2, 10
Climate Control System	1	Regulator-Alternator	16
Clutch-Pedal Operated	1	Restraint System	18
Coil, Ignition	1	Rims	13
Connecting Rods	1	Rods-Connecting	4
Convenience Equipment	10, 11	Scrub Radius	14
Cooling System	1	Seats	17
Crankshaft	1, 4	Shock Absorbers, Front & Rear	11
Cylinders and Cylinder Head	3	Spark Plugs	16
Diesel Information	4	Speedometer	15
Dimension Definitions		Springs-Front & Rear Suspension	11
Key Sheet-Exterior	28, 31, 32	Stabilizer (Sway Bar)-Front & Rear	11
Key Sheet-Interior	29, 30, 32, 33, 34	Starting System	16
Electrical System	15, 16	Steering	14
Emission Controls	7	Suppression-Ignition, Radio	16
Engine-General		Suspension-Front & Rear	11
Bore, Stroke, Type	3	Tail Pipe	7
Compression Ratio	2	Theft Protection	21
Displacement	2, 3	Thermostat, Cooling	5
Firing Order, Cylinder Numbering	3	Tires	13
General Information, Power & Torque	2	Toe-in	15
Intake System	4	Torque Converter	9
Power Teams	2	Torque-Engine	2, 8, 9
Exhaust System	7	Trailer Towing	21
Equipment Availability, Convenience	10	Transaxle	9
Fan, Cooling	5	Transmission-Types	2, 8, 9
Filters - Engine Oil, Fuel System	4	Transmission-Automatic	2, 9
Four Wheel Drive	10	Transmission-Manual	2, 8
Frame	17	Transmission-Ratios	2, 8, 9
Front Suspension	11	Tread	22
Front Wheel Drive Unit	10	Trunk Cargo Load	1
Fuel Economy, EPA	1	Trunk Luggage capacity	23
Fuel Injection	6	Turning Diameter	14
Fuel System	6	Unitized Construction	18
Fuel Tank	6	Universal Joints, Propeller Shaft	10
Glass	18	Valve System	4
Headlamps	18	Vehicle Dimensions	
Headroom-Body	23, 24	Width	22
Heights	22	Length	22
Horns	15	Height	22
Horsepower-Brake	2	Ground Clearance	22
Ignition System	16	Front Compartment	23
Inflation-Tires	13	Rear Compartment	23
Interior Volumes	23	Luggage Compartment	23
Instruments	15	Station Wagon-Third Seat	24
Legroom	23, 24	Station Wagon-Cargo Space	24
Lengths	22	Hatchback-Cargo Space	24
Leveling, Suspension	11	Fiducial Marks	25
Lifters, Valve	4	Voltage Regulator	16
Linings-Clutch, Brake	8, 12	Water Pump	5
Lubrication-Engine Transmission/Transaxle	4, 8, 9	Weights	26, 27
Luggage Compartment	23	Wheel Alignment	15
Models	1	Wheelbase	22
Motor Starting	16	Wheels & Tires	13
Muffler	7	Wheel Spindle	14
		Widths	22
		Windshield	18
		Windshield Wiper and Washer	15

1000

1000

1000

1000

1000

1000

1000

1000

1000

1000

1000