

4-SPEED TRANSMISSION I.D. CHART

Early models have only these tapped holes

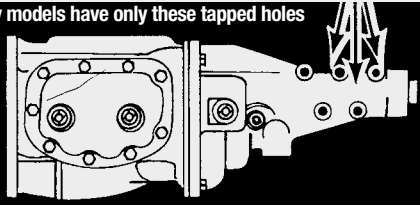

BORG-WARNER T-10, GM AS-3 (410)
9 bolt curved bottom side cover

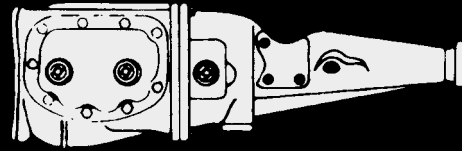

BORG-WARNER T-10, SUPER T-10, FORD/MERCURY (411)
9 bolt curved bottom side cover

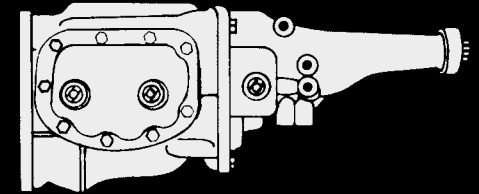

BORG-WARNER T-10, FORD/MERCURY (412)
9 bolt curved bottom side cover

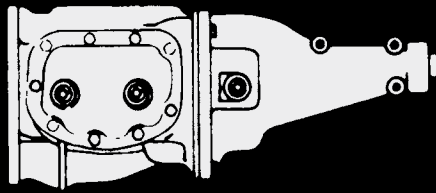

BORG-WARNER T-10 FORD/MERCURY (413)
9 bolt curved bottom side cover

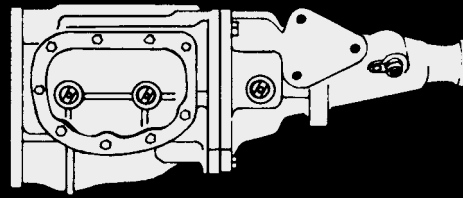

BORG-WARNER T-10, FORD/MERCURY (414)
9 bolt curved bottom side cover

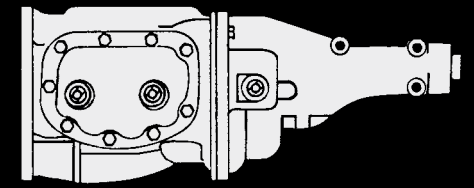

BORG-WARNER T-10 (415)
4 bolt side cover with round gear selection shafts

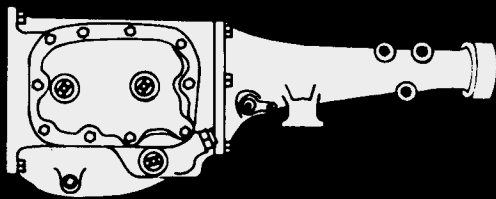

NEW PROCESS, MOPAR A-BODY (421)
10 bolt side cover

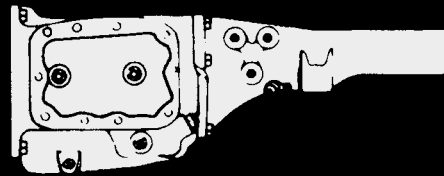

NEW PROCESS, MOPAR B-BODY (422)
10 bolt side cover

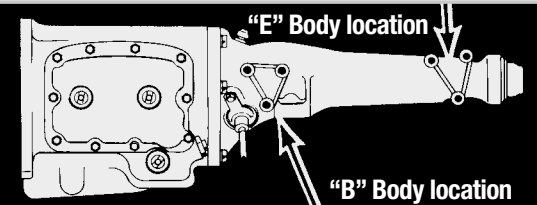

NEW PROCESS, MOPAR (423)
10 bolt side cover

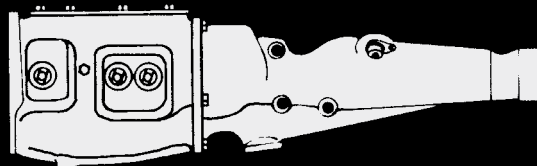

FORD T & C, FORD/MERCURY (431)
10 bolt top cover

Tapped on Falcon/Comet

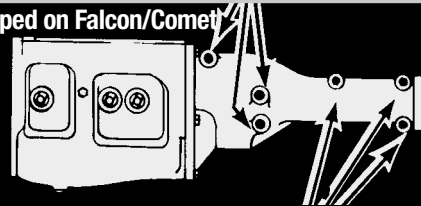

FORD 3+1 OVERDRIVE T & C, FORD/MERCURY (432)
10 bolt top cover

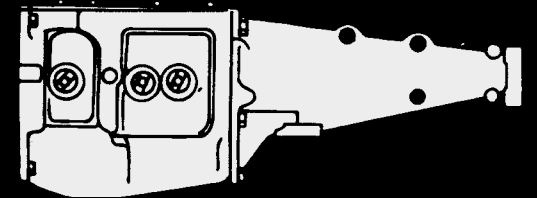

FORD T & C, FORD/MERCURY (433)
10 bolt top cover



4-SPEED TRANSMISSION I.D. CHART (continued)

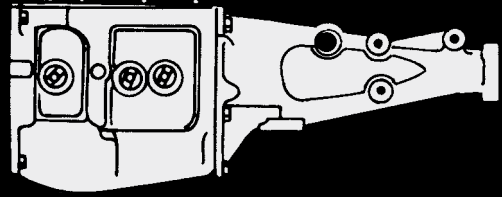

FORD T & C, FORD/MERCURY (434)
10 bolt top cover

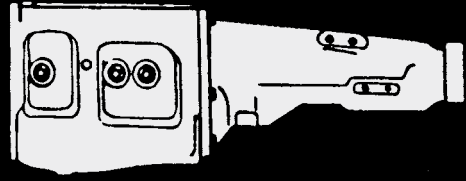

FORD 3+1 OVERDRIVE FORD/MERCURY (435)

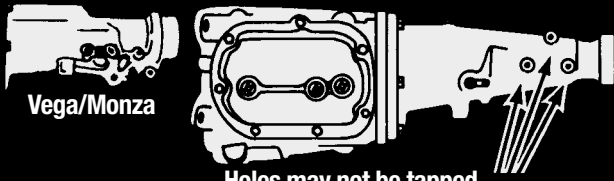

Vega/Monza
SAGINAW, G.M. (441)
7 bolt side cover
Holes may not be tapped

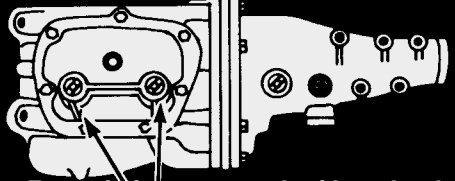

Transmission arms attach with stud and nut*
MUNCIE M-20/M-21 EARLY, G.M. (451)
7 bolt side cover used from 1963-68

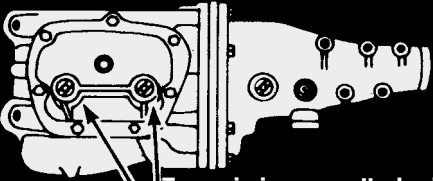

Transmission arms attach with bolt*
MUNCIE M-20/M-21, G.M. (452)
7 bolt side cover 1969 and later

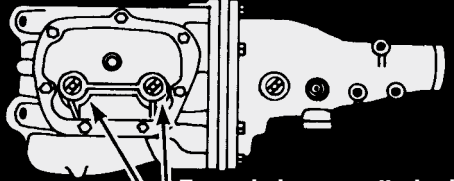

Transmission arms attach with bolt
MUNCIE M-22 (453)
G.M. 7 bolt side cover 1970, 454 Chevelle

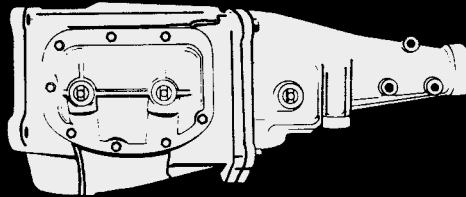

RICHMOND/BORG-WARNER SUPER T-10, (AS-9) 1974 and later (454)
9 bolt curved bottom side cover

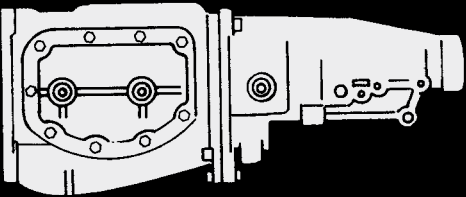

BORG-WARNER TORQUE TUBE TAILSHAFT, G.M. (455)
81-82 CAMARO/FIREBIRD 9 bolt side cover

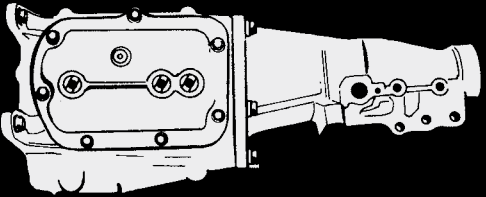

SAGINAW TORQUE TUBE TAILSHAFT, G.M., 81-82 CAMARO/FIREBIRD (456)
7 bolt side cover

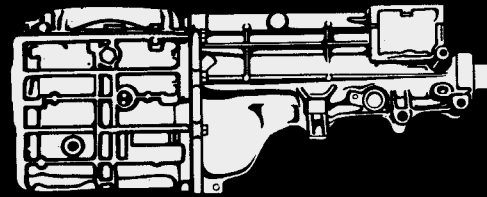

BORG-WARNER T-4 (464)
Internal Rail

*** MUNCIE Shaft Identification**

The above Muncie 4 speed transmissions can be distinguished from the style of the transmission arm attachment. Pre '69 Muncie's use a stud & nut at the indicated attachment point, while '69 and later Muncie's use a bolt as illustrated on the right.

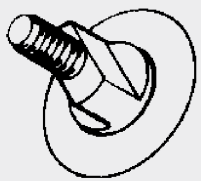

PRE '69 MUNCIE & ALL BORG-WARNER SHAFTS



'69 & LATER MUNCIE

