

CHEVROLET

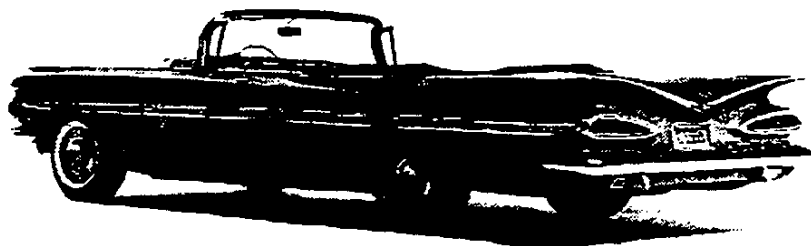

1959 Chevrolet, Impala two-door convertible, V-8

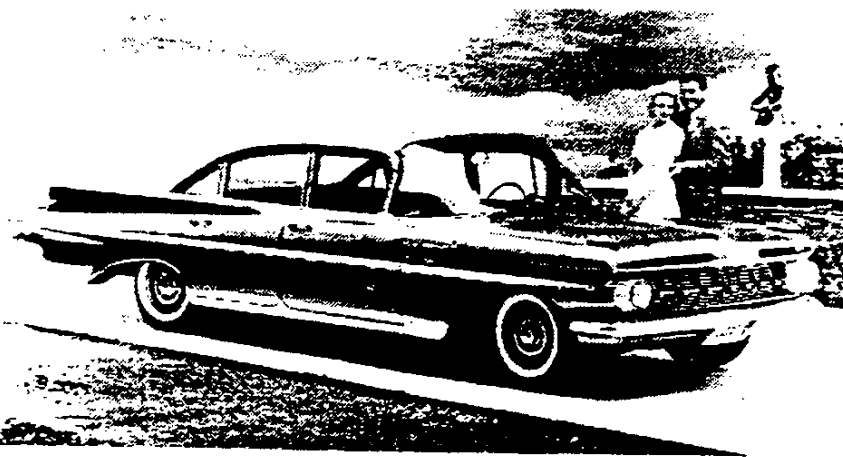

1959 Chevrolet, Bel Air four-door sedan, 6-cyl (AA)

1959

11

1959
CHEVROLET PASSENGER CAR
SPECIFICATIONS

CHEVROLET ENGINEERING CENTER



ENGINEERING PRODUCT INFORMATION DEPARTMENT
WARREN, MICHIGAN • OCTOBER, 1958

INTRODUCTION

AUTOMOBILE SPECIFICATIONS...

In the automobile industry, a specification is defined as any item in a detailed description of a mechanism. Usually the description is composed of separate specifications in tabular question and answer form.

Specifications of this nature, however, are not required in the manufacture of an automobile. All the information necessary for this process is given by the Engineering Department to the manufacturing and assembling plants in the forms of drawings and parts lists. But drawings and parts lists usually are not made available to other people who require information of the vehicle, since these records must be interpreted. Moreover, they and other engineering records are much too numerous or voluminous for convenient reference. Therefore, a special interpretation is made by the Engineering Department in the form of a specifications list or book, the contents of which are determined by the nature of questions people ask the Engineering Department concerning the vehicle.

As has been the experience of most manufacturers, originally the questions asked were few in number and were answered individually at the time they were asked. Through the years, however, many questions were asked quite frequently and, for convenience, the answers were recorded in the form of specifications. Others, which arose because of heightened interest and because of advancements in design, were added from time to time. As the automobile grew into a necessary means of transportation --- as its component units were advanced in design and as new ones were added --- and as manufacturers were forced to make more detailed comparisons of their vehicles with those of their competitors to satisfy an increasingly technically minded public --- more and more questions concerning the various characteristics of vehicles were answered in the form of specifications.

THE PURPOSE OF CHEVROLET SPECIFICATIONS...

The Chevrolet Engineering Department has always been willing to answer questions of a technical nature concerning Chevrolet products and for the past thirty years has endeavored to anticipate such questions by preparing a specifications book each new model year.

This current book has been prepared to answer all the questions concerning the Chevrolet 1959 products that we believe may be asked.

It is intended primarily as a convenient and authoritative source of information for all Chevrolet executives, engineers, sales and service representatives, plant managers, and other personnel who must be in a position to answer such questions, and also as a common source of those Chevrolet specifications that are needed in advertisements, vehicle comparisons, trade publications, license applications and in correspondence with governments, firms, educational institutions, and individuals throughout the world who require a wide variety of information about Chevrolet products for diverse purposes.

VEHICLES AND EQUIPMENT SPECIFIED...

The specifications are those of all standard left drive passenger and delivery cars which have been designed to be manufactured for the domestic (U.S.A.) open market. Included also are the specifications of the RPO (Regular Production Option) units which are intended for use with these vehicles. All data are for vehicles with regular equipment, except where noted as RPO.

No information is furnished concerning right drive vehicles of equipment manufactured for export, nor any vehicles or equipment built on COPO's (Central Office Production Orders) or any other special orders. Accessories released through the Parts and Accessories Department, however, are listed although specifications are not included. This publication covers all passenger cars, including the Corvette. Also covered are Sedan Delivery and Sedan Pickup models.

Except where noted, all information was derived directly from official Chevrolet Engineering Department drawings, parts lists, and test reports, or was calculated from these records.

ABBREVIATIONS...

The data are presented in a condensed tabular form which necessitates the use of abbreviations or symbols in some cases. These are shown on a separate page.

DIMENSIONS...

The dimensions shown are of three types:

Type #1. Those dimensions where very accurate fits are essential in the parts concerned, such as bearing surfaces and splines, and where dimensions usually are expressed on drawings in decimals with very close limits.

Type #2. Those dimensions where accuracy of fit is of less importance, as in structural members such as frame parts, I-beam axles, or in fuel tanks; also, dimensions for the purpose of identification, such as cylinder bore, or diameter of the wheel cylinder piston, where dimensions are expressed in fractions or integers with fractions and to which fairly large tolerances ($\pm/64$, $\pm/32$, $\pm/16$) are applied.

Type #3. Those dimensions, such as wheelbases, ground clearances, body size dimensions, and turning diameters, which are subject to large manufacturing variations.

In this book, the dimensions of type #1 are quoted with limits exactly as on the drawings while the dimensions of types #2 and #3 are quoted without manufacturing tolerances.

Unless specified otherwise all dimensions are in inches.

LOCATION OR POSITION OF PARTS...

When referring to the location or position of any engine part or vehicle unit, the practice throughout the automotive industry is that such reference is made from the driver seat position. Any views shown or references made, which are contrary to the above rule, are clearly labelled or explained in the text of the specifications.

ORGANIZATION OF BOOK...

Every effort has been made to facilitate the finding of information. The sequence followed in presenting the information is that of the G. M. Uniform Parts Classification major groupings, modified to facilitate usage by the reading majority, who are unacquainted with this classification. The title page for each section lists the subjects in the order in which they occur in that section. The title for each section, such as CHASSIS, is printed at the bottom of each page beside the page number. The index lists the details covered by the title headings.

Tabs are provided for conveniently locating basic sections such as BODY AND SHEET METAL and ENGINES AND CLUTCHES.

REVISIONS...

All revisions and the dates on which they are made will be indicated at the bottom of the page on which they occur. Where it is necessary to indicate a change in an individual specification, a symbol will be placed in the proximity of the revised specification. This symbol also will be repeated at the bottom of the page with a description of the revision. The following symbols have been established for this purpose: o, x, +, v, *, -. They may be used singly, in multiples or in combinations.

Subsequent revisions on a revised page will be made in the same manner as described above. However, to emphasize and clarify the later changes, all symbols and descriptions pertaining to previous revisions will be removed and a note added including the previous date of change preceded by the word "Revised".

ADDRESS ALL INQUIRIES TO
ENGINEERING PRODUCT
INFORMATION DEPARTMENT

Room 3-312, Chevrolet
Engineering Center
Box 246 North End Station
Detroit 2, Michigan
Or Call

Jefferson 9-5000, Extension 3005 or 3006

ABBREVIATIONS AND SYMBOLS

AC Spark Plug Division ----- AC
 Acting ----- Act
 Adjustment ----- Adj
 After Bottom Center ----- ABC
 After Top Center ----- ATC
 Aluminum ----- Al
 Ampere ----- Amp
 Approximately ----- Approx
 Assembly ----- Assem
 Automatic ----- Auto
 Auxiliary ----- Aux
 Average ----- Avg

Barometric ----- Bar
 Barrel ----- Bbl
 Battery ----- Bat
 Bearing ----- Brg
 Before Bottom Center ----- BBC
 Before Top Center ----- BTC
 Before Top Dead Center --- BTDC
 Bolt Circle ----- BC
 Bracket ----- Brkt
 Brake Horsepower ----- BHP
 Bushing ----- Bush

Cab-Over-Engine ----- COE
 Candle Power ----- CP
 Camshaft ----- Cam
 Capacity ----- Cap
 Carburetor ----- Carb
 Cast Iron ----- CI
 Center of Gravity ----- CG
 Change ----- Chg
 Circumference ----- Circum
 Column ----- Col
 Commercial ----- Comm
 Compression ----- Comp
 Conditioning ----- Cond
 Connecting ----- Conn
 Continue ----- Cont
 Conventional & Convertible -- Conv
 Central Office Production Order --
 ----- COPO
 Cross Member ----- CM
 Cubic Feet ----- Cu Ft
 Cubic Inches ----- Cu In
 Cylinder ----- Cyl

Daylight Opening ----- DLO
 Decalcomania ----- Decal
 Degree ----- Deg
 Delivery ----- Del
 Designation ----- Design
 Diameter ----- Dia
 Dimension ----- Dim
 Displacement ----- Displ
 Distributor ----- Distr
 Division ----- Div
 Double ----- Dbl
 Double Row ----- DR
 Drawing ----- Dwg

Each ----- Ea
 Effective ----- Eff
 Electric ----- Elect
 Engine ----- Eng
 Equipment ----- Equip
 Equivalent ----- Equiv
 Etcetera ----- Etc
 Except ----- Exc
 Exhaust ----- Exh
 Exterior ----- Ext

Factory Optional Accessory - FOA
 Fahrenheit ----- F
 Feet ----- Ft
 Feet Per Minute ----- Ft/Min
 Figure ----- Fig
 Foot Pounds ----- Ft-Lb
 Front ----- Fr

Gallon ----- Gal
 Gallons Per Minute ----- GPM
 General Motors ----- GM
 Generator ----- Gen
 Governor ----- Gov

Heavy Duty ----- HD
 Horsepower ----- Hp
 Hot Rolled ----- HR
 Hour ----- Hr
 Housing ----- Hsg
 Hydraulic ----- Hyd

Identification ----- Id
 Ignition ----- Ign
 Inches ----- In
 Inches Cubed ----- In³
 Inches to the Fourth Power --- In⁴
 Included ----- Incl
 Inside Diameter ----- ID
 Instrument ----- Inst
 Intermediate ----- Inter

Joint ----- Jt

Kilometer ----- Kilo

Laminated Safety Plate ----- LSP
 Left ----- L
 Left Hand ----- LH
 Light ----- Lt
 Limited Production Option --- LPO
 Lubricate ----- Lub

Material ----- Matl
 Maximum ----- Max
 Medium ----- Med
 Members ----- Mbrs
 Mercury ----- Hg
 Mile ----- Mi
 Miles Per Hour ----- MPH
 Millimeter ----- MM
 Minutes & Minimum ----- Min
 Miscellaneous ----- Misc
 Model, Modified & Modulus -- Mod
 Mounting ----- Mtg

Negative ----- Neg
 New Departure ----- ND
 Nominal ----- Nom
 Number ----- No

Odometer ----- Odorn
 Operation ----- Oper
 Opposite ----- Opp
 Optional ----- Opt
 Ounce ----- Oz
 Outside Diameter ----- OD
 Overdrive ----- Od

Page ----- P
 Pages ----- Pp
 Passenger ----- Pass
 Piece ----- Pc
 Pint ----- Pt
 Pitch Diameter ----- PD
 Ply Rating ----- Pr
 Pound ----- Lb
 Pounds Per Square Inch ----- PSI
 Power ----- Pwr
 Powerglide ----- PG
 Preliminary ----- Prelim
 Pressure ----- Press
 Product or Production ----- Prod
 Projected ----- Proj
 Propeller ----- Prop

Quality ----- Qual
 Quantity ----- Quan
 Quart ----- Qt
 Quarter ----- Qtr

Radiator ----- Rad
 Radius & Roller ----- R
 Rear ----- Rr
 Reference ----- Ref
 Regular & Regulator ----- Reg
 Regular Production Option -- RPO
 Reinforce & Reinforcement - Reinf
 Required ----- Req'd
 Retaining ----- Ret
 Reverse & Revolutions ----- Rev
 Revolutions Per Mile ----- Rev/Mi
 Revolutions Per Minute ----- RPM
 Right ----- Rt
 Rubber ----- Rub

Safety Solid Plate ----- SSP
 Saginaw ----- Sag
 Section ----- Sect
 Sedan ----- Sed
 Sheet ----- Sh
 Single Row ----- SR
 Society of Automotive Engineers --
 ----- SAE
 Society of Fuse Engineers --- SFE
 Speedometer ----- Speedo
 Spherical ----- Spher
 Spring ----- Spr
 Square ----- Sq
 Square Inches ----- Sq. In
 Standard ----- Std
 Steel ----- Stl
 Steering ----- Strg
 Suspension ----- Susp

Tachometer ----- Tach
 Temperature ----- Temp
 That Is ----- ie
 Theoretical ----- Theo
 Thread ----- Thd
 Tolerance ----- Tol
 Transmission ----- Trans
 Turboglide ----- TG

 Vacuum ----- Vac
 Velocity ----- Vel
 Visibility Area ----- VA
 Volume ----- Vol

 Wagon ----- Wgn
 Weight ----- Wt
 Wheel ----- Whl
 Windshield ----- W/S

SYMBOLS

And ----- &
 At ----- @
 By, Times ----- x
 Center Line ----- C
 Degrees ----- °
 Divided By ----- ÷
 Inches or Seconds ----- ''
 Minus ----- -
 Minutes ----- '
 Number or Pounds ----- #
 Per ----- /
 Per Cent ----- %
 Plus ----- +
 To (Range) ----- -
 To (Ratio) ----- :

GENERAL

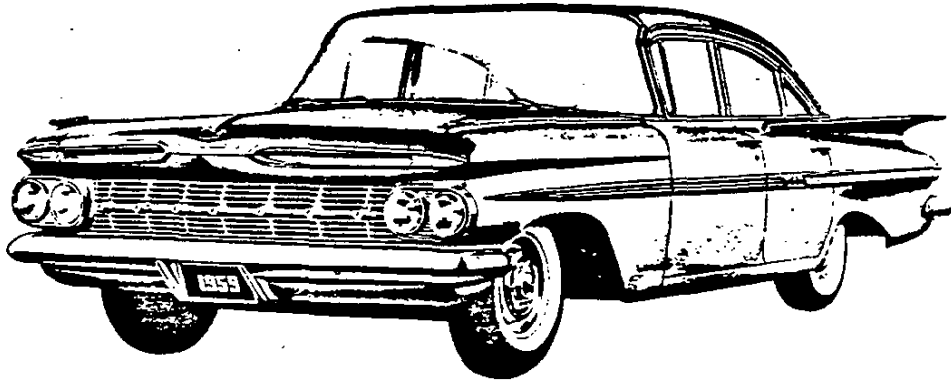

MODEL IDENTIFICATION	2
SERIAL NUMBERS AND IDENTIFICATION	4
REGULAR EQUIPMENT - EXTERIOR	6
REGULAR EQUIPMENT - INTERIOR	7
OPTIONAL EQUIPMENT	8
DEALER INSTALLED ACCESSORIES	9
VEHICLE WEIGHTS	10
TAXI-CAB EQUIPMENT	12
POLICE CAR EQUIPMENT	13
AIR CONDITIONING	14

MODEL IDENTIFICATION

BISCAYNE SERIES



Model 11-1211;11-1221—2-door, 6-passenger, 4 window Sedan, luggage compartment in rear.

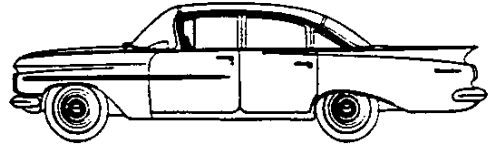

Model 11-1219 — 4-door, 6-passenger, 6 window Sedan, luggage compartment in rear.

BEL AIR SERIES

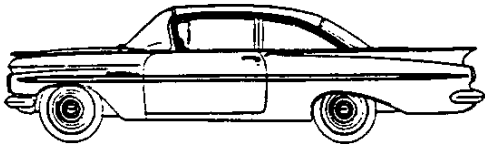

Model 15-1611 — 2-door, 6-passenger, 4 window Sedan, luggage compartment in rear.

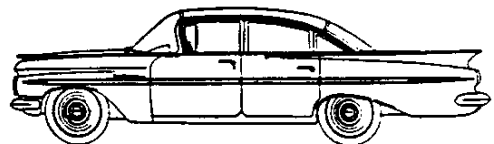

Model 15-1619 — 4-door, 6-passenger, 6 window Sedan, luggage compartment in rear.

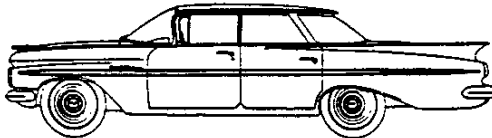

Model 15-1639—4-door, 5-passenger, 4-window Sport Sedan, luggage compartment in rear.

IMPALA SERIES



Model 17-1837 — 2-door, 5-passenger, 4 window Sport Coupe, luggage compartment in rear.

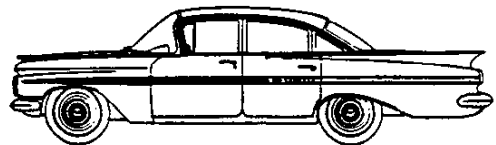

Model 17-1819 — 4-door, 6-passenger, 6 window Sedan, luggage compartment in rear.



Model 17-1867 — 2-door, 5-passenger, 4 window Convertible, luggage compartment in rear.

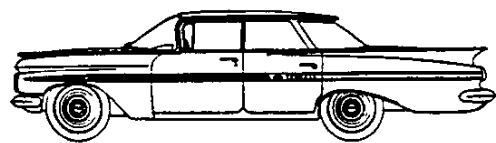

Model 17-1839 — 4-door, 5-passenger, 4-window Sport Sedan, luggage compartment in rear.

MODEL IDENTIFICATION

STATION WAGON SERIES

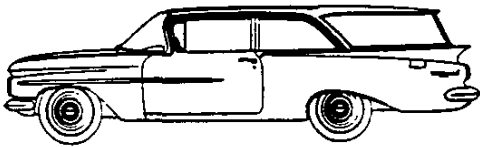

Model 11-1215 Brookwood — 2-door, 6 passenger, 6 window Station Wagon, drop gate in rear with retractable window.

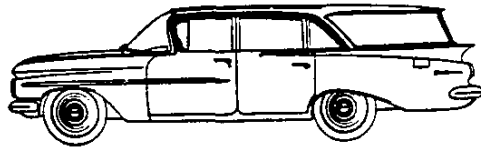

Model 11-1235 Brookwood — 4-door, 6 passenger, 8 window Station Wagon, drop gate in rear with retractable window.

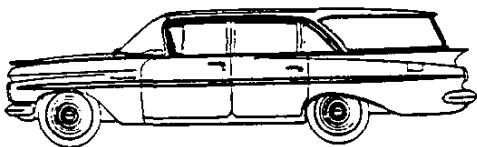

Model 15-1635 Parkwood — 4-door, 6 passenger, 8 window Station Wagon, drop gate in rear with retractable window.

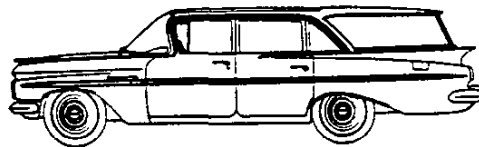

Model 15-1645 Kingswood — 4-door, 9 passenger, 8 window Station Wagon, drop gate in rear with retractable window.



Model 17-1835 Nomad — 4-door, 6-passenger, 8 window Station Wagon, drop gate in rear with retractable window.

COMMERCIAL MODELS

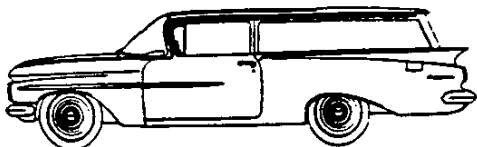

Model 11-1270 El Camino — 3-door, 3-passenger, 2-window Sedan Delivery, swing up door in rear.

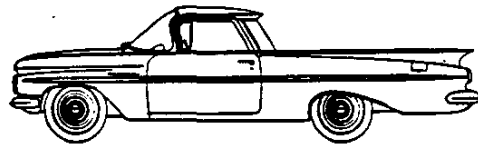

Model 11-1280 El Camino — 2-door, 3-passenger, 2 window Sedan Pickup, drop gate in rear.

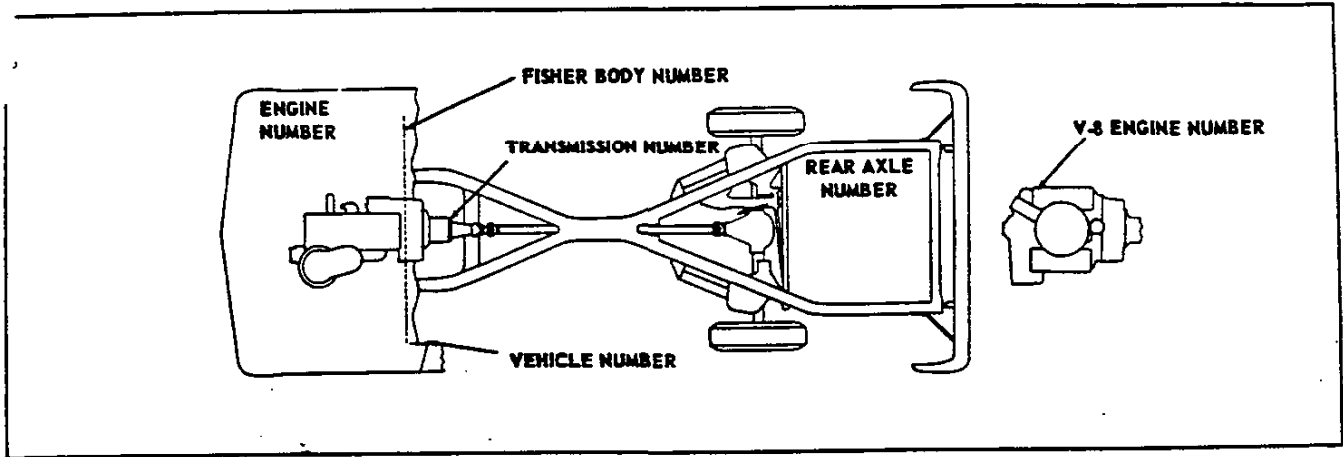

SERIAL NUMBERS AND IDENTIFICATION

VEHICLE SERIAL NUMBER

6-Cylinder Example:

Series	Model year	Assembly plant	Unit number
A	59	T	100025

8-Cylinder Example:

Series	Model year	Assembly plant	Unit number
B	59	T	100026

With 6-Cylinder Engine:

Series	Model year	Assembly plant	Unit number
A	1100 (except 1170-1180)	A-Atlanta	
C	1500	B-Baltimore	
E	1700	F-Flint	
G	1170-1180	J-Janesville	
		K-Kansas City	

With 8-Cylinder Engine:

Series	Model year	Assembly plant	Unit number
B	1200 (except 1270-1280)	L-Los Angeles	
D	1600	N-Norwood	
F	1800	O-Oakland	
H	1270-1280	S-St. Louis	
		T-Tarrytown	

Starting Unit Number ----- 100001
and up at each assembly plant regardless of series.
Location ----- Stamped
on plate attached to left front body hinge pillar.

ENGINE IDENTIFICATION

Example: F 1210 CD

Source	Production	Type
Designation	Month & Date	Designation
F	1210	CD
Assembly Plant:	F - Flint	T - Tonawanda

6-Cylinder: (235)

- A - Regular production engine with 3-speed or overdrive
- AE - Regular with heavy-duty clutch (1119-1519 taxi cab)
- B - Regular with Powerglide

8-Cylinder Engine (283)

- C - Regular production engine
- CD - Regular with overdrive
- CF - Regular with 4-barrel carburetor equip.
- CG - Regular with 4-bbl. carb. & overdrive
- CH - Regular with fuel injection
- CJ - Regular with fuel injection & Hi-lift cam
- D - Regular with Powerglide
- DB - Regular with 4 bbl. carb. & Powerglide
- DE - Regular with air suspension & Powerglide
- DF - Regular with air susp., 4 bbl. carb. & PG
- DK - Regular with air cond. & PG
- DL - Regular with air cond., PG & air susp.
- DM - Regular with air cond., PG & 4 bbl. carb.
- DN - Regular with a/c PG, 4 bbl. carb., & air susp.
- DP - Regular with fuel injection & PG

- E - Regular with Turboglide
- EB - Regular with 4 bbl. carb. & Turboglide
- EC - Regular with fuel injection & Turboglide
- ED - Regular with air suspension & Turboglide
- EF - Regular with air susp. 4 bbl. carb. & TG
- EG - Regular with air cond. & TG
- EH - Regular with air cond., TG, & air susp.
- EJ - Regular with air cond. TG, & 4-bbl. carb.
- EK - Reg. with air cond. TG, 4-bbl. carb. & air susp.
- F - 348 optional engine
- FA - 348 with triple 2-bbl. carb. equip.
- FB - 348 with triple 2-bbl. carb. & Hi-lift cam
- FD - 348 with 4-bbl. carb. & Hi-lift cam
- FE - 348 with triple 2-bbl. carb. & Hi-lift cam
- FG - 348 with 4-bbl. carb. & Hi-lift cam
- G - 348 with Powerglide
- GB - 348 with triple 2-bbl. carb. & PG
- GD - 348 with 4-bbl. carb. Hi-lift cam & PG
- H - 348 with Turboglide
- HA - 348 with triple 2-bbl. carb. & TG

Location:

- 6 cylinder engine ----- Stamped on pad on right side of cylinder block, to rear of distributor.
- 8 cylinder engine ----- Stamped on pad at front right side of cylinder block.

TRANSMISSION IDENTIFICATION

Example: Plant & Type Month Day of Shift
 Designation Month
 M 11\$ 26\$ D¢

Prefix	Plant	Type
M	Muncie	3-speed & O.D.
S	Saginaw	3-speed & O.D.
C	Cleveland	Powerglide
B	Toledo	Turboglide

Location, 3-Speed ----- Stamped on rear face of case on upper right corner.
 Powerglide ----- Stamped on rear flange of governor cover.
 Turboglide ----- Stamped on boss on lower right rear of case.

REAR AXLE IDENTIFICATION

Example: AA 212

Plant and Type	Production	Date
Designation	Month \$	Day\$
AA	2	12

Gear & Axle Buffalo

AA -----	BA --	348 4-sp; 348 PG & hi-lift cam
AB -----	BB -----	348 TG & PG; 348 3-sp
AD -----	BD ---	Taxi cab, 3.36:1 ratio W/PG
AG -----	BG -----	Taxi cab, 3.55:1 ratio
AK -----	BK -----	Limited slip, 3.55:1 ratio
AM -----	BM -----	Limited slip, 3.36:1 ratio
AW -----	BW -----	W-engine, 3.08:1 ratio
AX -----	BX -----	Limited slip, 3.08:1 ratio
FH -----	BH -----	Limited slip, 3.70:1 ratio

Location ----- Stamped front right side of differential carrier.

¢ - D denotes day shift; N denotes night. (PG & TG only)
 \$ - Month: 1 denotes January etc.; 01 denotes 1st day etc.

**1959 PASSENGER CAR
REGULAR EQUIPMENT - EXTERIOR**

ITEM		MODELS	
Front and rear bumpers with twin vertical guards		All	
Dual headlights			
Twin parking and direction signal lights			
Twin tail, stop and direction signal lights			
Rear license lamps (two)		All except Station Wagons\$	
Deck lid emblem			
Hub caps		All	
Push-button door handles			
Outside key locks below front door handles			
Dual windshield wipers, electric, single-speed			
Dual horns			
Anodized Aluminum	Grille body and screen		1700-1800
	Air inlet frames and screens		
	Tail light bezels		
	Tail light dividing strips	1100-1200 exc. 1180-1280	
	Body side molding		
	Headlight bezels		
Parking light bezels		All	
Chevrolet script on hood		1500-1600-1700-1800	
Chevrolet script and "V" on hood (283 V-8 only)			
Chevrolet script, "V", and crossed flags on hood (348 V-8 only)			
Front fender ornaments		1700-1800	
Front fender crown moldings			
Twin back-up lights		All except Station Wagons Station Wagons\$	
Gasoline filler behind rear license area			
Gasoline filler door on left hand rear quarter panel		1500-1600‡	
Series script on front fenders		1100-1200-1700-1800#	
Series script on rear door or rear quarter panel		1719-1819-1737-1837-1739-1839	
Simulated exhaust port above rear window		All	
Deck lid or tailgate medallion		1170-1270	
Outside rear view mirror - L.H.		All	
Bonderized body and sheet metal		1545-1645	
Electric rear window regulator		All Station Wagons except 1545-1645	
Manual rear window regulator			
Bright-metal Moldings	Windshield reveal	All	
	Deck lid or tailgate peak		
	Rear quarter panel peak		
	Ventipane channel and post	1500-1600-1700-1800-1180-1280	
	Body side, double with insert area		
	Drip cap	1180-1280-1500-1600-1700-1800 except 1767-1867-1170-1270	
	Windshield pillar		
	Rear window upper, side, and lower	All except Station Wagons and Convertible*	
	Door upper frame and rear quarter window reveal	1719-1819-1735-1835	
	Roof side and rail	1737-1837-1739-1839-1180-1280	
	Roof rear	1739-1839-1180-1280	
	Belt reveal	1700-1800-1180-1280	
	Deck lid center	1700-1800 except 1735-1835	
	Rear license opening		
	Tailgate window reveal, side, and top	All Station Wagons	
	Tailgate pillar cap	1535-1635-1545-1645-1735-1835	
	Tailgate window lower reveal		
Rear quarter window reveal			
Pickup box rail	1180-1280		

\$ - And models 1170-1270; 1180-1280

‡ - And models 1180-1280

- Except 1180-1280

* - And models 1170-1270

**1959 PASSENGER CAR
REGULAR EQUIPMENT - INTERIOR**

ITEM		MODELS	
Instrument Panel	Ignition switch identification plate	1100-1200	
	Anodized aluminum trim molding	1500-1600	
	Anodized aluminum trim molding and plate	1700-1800	
	"Chevrolet" nameplate	1100-1200-1500-1600-1735-1835	
	"Impala" nameplate	1700-1800 except 1735-1835	
	Black plastic control knobs	1100-1200	
	Chrome-capped control knobs	1500-1600-1700-1800	
	Black plastic vent control knobs	All	
	Electric clock	1700-1800	
	Parking brake alarm		
	Glove compartment	Light	1500-1600-1700-1800
		Lock	All
	Cigarette lighter	1500-1600-1700-1800	
	Ash tray	All	
3-Position ignition lock and starter switch			
Steering Wheel	Deep hub, perforated spokes, half-circle horn ring	1700-1800	
	Deep hub, dual solid spokes, half-circle horn ring	1500-1600	
	Deep hub, dual solid spokes, horn button	1100-1200	
Crank type front ventipanes	All		
Coat hooks	All except 1767-1867-1170-1270-1180-1280		
Door locking knobs	All		
Rear seat speaker grille	1737-1837-1767-1867		
Inside rear view mirror	All except 1170-1270		
Rear window control switch on instrument panel	1545-1645		
Interior Lights	Single dome, center	All except 1739-1839-1737-1837-1767-1867†	
	Dual side rail	1739-1839-1737-1837	
	Dual in dash	1767-1867	
	Third seat, courtesy	1545-1645	
Manual interior light switch integral with headlight switch (main switch)	All		
Automatic interior light switch, front doors only	1500-1600-1700-1800		
Sunshades	Dual	1500-1600-1700-1800	
	Left hand only	1100-1200	
Front and rear seat padding	See page 18 - Body and S.M.		
Aluminum seat end panels	1700-1800		
Armrests front and rear doors or quarter panels	1500-1600-1700-1800		
Ash tray, rear door or quarter panels	1500-1600-1700-1800		
Door remote control handle, conventional type	All except 1700-1800		
Door remote control handle, paddle type	1700-1800		
Floor Covering	Carpet	1700-1800	
	Carpet, vinyl-covered inserts	1500-1600	
	Rubber mat, vinyl-covered	1100-1200	
	Vinyl-type cargo floor and covered wheelhouses	Station Wagons	
	Painted load floor and wheelhouses	1170-1270; 1180-1280	
Bright Metal Moldings	Windshield, upper and side	1737-1837-1739-1839	
	Rear window, upper and side		
	Front door, rear door or rear quarter trim	1700-1800	
	Side roof rails	1737-1837-1739-1839	

† - Also 1170-1270

* - Polyurethane and cotton rear seat cushion on 17-1819; 17-1837; 17-1839; 17-1867

**1959 PASSENGER CAR REGULAR PRODUCTION
OPTIONS AND FACTORY OPTIONAL ACCESSORIES**

GROUP	ITEM	NUMBER	MODELS	
Engine	Air cleaner, oil bath	216	Series 11-15-1700	
	Carburetor (s)ff	Single 4-barrel	410	Series 12-16-1800
		Triple 2-barrel	573-574%	Series 12-16-1800s
	Clutch, heavy-duty	227	Series 11-15-1700	
	Engine, 348 cubic inch V-8	576-577A	Series 12-16-1800s	
	Exhaust, dual	220	Series 12-16-1800	
	Fan, thermostatically controlled	121*		
	Filter, oil	237	All	
	Fuel injection	578	Series 12-16-1800s	
	Generators	35-amp.	338	All
40-amp.		326		
50-amp. (low cut-in)		378		
Transmission	Four-speed	685	Series 12-16-1800s	
	Overdrive	315	All	
	Powerglide	313		
	Turboglide	302	Series 12-16-1800	
Chassis	Axle, rear (limited-slip)	675	All	
	Battery, heavy-duty (11-plate, 70 amp.)	345		
	Brakes, power	412		
	Disks, wheel	117*		
	Springs, rear (heavy-duty)	593		
	Steering, power	324		
	Suspension, air	580	Series 12-16-1800s	
	Tires	7.50 X 14-4 ply (whitewall)	465	All except 11-1215, 35, S;
		8.00 X 14-4 ply (blackwall)	283	15-1635, 45; 17-1835, 67
8.00 X 14-4 ply (whitewall)		588	All	
8.50 x 14-4 ply (blackwall)		366	1170-80; 1270-80	
8.50 x 14-4 ply (whitewall)		368		
Body	Air conditioning	110*	Series 12-16-1800s	
	Cushion, foam rubber front seat	335	Series 11-1200s	
	Deluxe body equipmentff	347		
	Deluxe steering wheel	348	Series 11-1200	
	Glass	Tinted (rear window only)	388	17-1837 only
		Tinted	398	All
	Heater and Defroster	Air flow	101*	
		Recirculating	116*	
	Pad, instrument panel		427	
	Radio and Antenna	Manual	103*	
		Push-button	104*	
	Seat, 6-way power		380	Series 15-16-17-1800
	Taxicab equipment**		330	11-12-15-1619 only
	Top, folding (colors)		470	17-1867 only
	Washer, push-button windshield		109*	All
	Wipers, 2-speed electric †		333	
	Window (s)	Power tailgate	424	15-16-17-1835 only
Power		426	Series 15-16-17-1800	
Seat	RF, auxiliary	263	1170-1270	
	Front, full width	482		

- * - Factory Optional Accessory. Also available as dealer-installed accessory.
- ff - Includes front fender ornaments, front armrests, right hand sunshade, and cigarette lighter.
- † - Includes push-button washers, and overlapping windshield wipers.
- ** - Also includes Chassis and Engine equipment.
- S - Except 1270.
- & - Except 1270-80.
- A - RPO 577 special cam 348 engine, 4-barrel carburetor.
- f - RPO 581 economy carburetor - 1100 series.
- % - RPO 574 triple 2-barrel special cam on 12-16-1800 with 348 engine.

**1959 PASSENGER CAR
DEALER-INSTALLED ACCESSORIES**

ITEM		MODELS	
Air Conditioner	Fresh air (All Weather)	Series 12-16-1800	
	Recirculating (Cool Pack)	All	
Alarm	Parking brake	Series 11-12-15-1600	
	Speed warning	All	
Antenna (radio)	Dummy	All except 11-1215, 35; 15-1635, 45; 17-1835	
	Manual		Left rear
			Right rear
	Right front	All	
Armrests	Front or rear	Series 11-1200	
Ash Tray	Vacuum	All	
Belt	Seat		
Brake	Vacuum power		
Cap	Gasoline tank filler locking		
Carrier	Luggage (rooftop-type)	All except 17-1867; 1170-80; 1270-80	
	Spare wheel (Continental-type)	All except 11-1215, 35; 15-1635, 45; 17-1835 1170-80; 1270-80	
Clock	Electric	Series 11-12-15-1600	
Container	Litter	All	
Compass	Illuminated		
Cover	Accelerator pedal		
	Front seat cushion		
	Wheel (disk-type)		
Deflectors	Rain	All except 17-1837, 39, 67; 1170-80; 1270-80	
Dimmer	Automatic headlight (Autronic Eye)	All	
Dispenser	Tissue	All	
Extension	Front door vent window		
Fan	Thermostatically controlled	1200-1600-1800	
Flasher unit	Traffic hazard	All	
Grille	Rear radio speaker	15-1645	
Guard	Door edge	All	
	Front bumper and grille		
	Gas filler and license plate		
Harness	Seat belt shoulder	11-1211, 19, 21; 15-1611, 19; 1170-80; 1270-80	
	Air flow		
Heater and Defroster	Recirculating	All	
	Ash tray		
Light(s)	Backing	Series 11-12-15-1600	
	Courtesy	All except 17-1867	
	Engine compartment	All	
	Glove compartment	Series 11-1200	
	Luggage compartment	All except 11-1215, 35; 15-1635, 45; 17-1835; 1170-80; 1270-80	
	Spot	Inside-operated	All
		Outside-operated	
		Portable	
Lighter	Cigarette	Series 11-1200	
Lock	Throttle	All	
Mat	Floor (front or rear)		
Mirror	Rear view	Inside (prismatic)	All, except 1170-1270
		Outside (door-mount)	
Moldings	Visor vanity	All	
	Body sill		
Ornaments	Front fender crown	Series 11-1200	
	Hub cap or wheel disk	All	
	Rear fender simulated exhaust		
Pad	Ventilated seat	All	
	Manual *		
Radio	Push-button *	All	
	Signal-seeking *		
	Radiator insect		
Shield	Door handle	17-1837	
	Windshield glare (plastic)		
	Rear window glare (plastic)		
Speaker	Rear radio	All except 1170-80; 1270-80	
Sunshade	Right hand	Series 11-1200	
Tool Kit	Washer	Push-button	All
		Foot-operated	

* - Includes front or rear antenna for sedan and sport models, front antenna only for station wagon models.

VEHICLE WEIGHTS

1100-1200 SERIES BISCAYNE

VEHICLE TYPE		SHIPPING WEIGHT			CURB WEIGHT			LOADED WEIGHT		
Model	Description	Front	Rear	Total	Front	Rear	Total	Front	Rear	Total
1111	2-Door Sedan 6-cylinder	1870	1665	3535	1880	1810	3690	2210	2380	4590
1111P		1950	1690	3640	1960	1840	3800	2290	2410	4700
1211	2-Door Sedan 8-cylinder	1845	1685	3530	1860	1830	3690	2190	2400	4590
1211P		1925	1710	3635	1940	1955	3795	2270	2425	4695
1211T		1855	1700	3555	1870	1845	3715	2195	2420	4615
1119	4-Door Sedan 6-cylinder	1880	1725	3605	1890	1870	3760	2220	2440	4660
1119P		1960	1750	3710	1975	1895	3870	2305	2465	4770
1219	4-Door Sedan 8-cylinder	1880	1720	3600	1890	1870	3760	2220	2440	4660
1219P		1955	1750	3705	1970	1895	3865	2300	2465	4765
1219T		1885	1740	3625	1900	1885	3785	2230	2455	4685
1121	Utility Sedan 6-cylinder	1850	1630	3480	1865	1770	3635	2095	1990	4085
1121P		1930	1655	3585	1945	1800	3745	2180	2015	4195
1221	Utility Sedan 8-cylinder	1845	1645	3490	1860	1785	3645	2090	2005	4095
1221P		1925	1670	3595	1940	1810	3750	2170	2030	4200
1221T		1850	1660	3510	1870	1800	3670	2100	2020	4120
1170	Sedan Delivery 6-cylinder	1885	1855	3640	1805	1975	3780	1885	2515	4400
1170P		1860	1885	3745	1885	2000	3885	1960	2545	4505
1270	Sedan Delivery 8-cylinder	1775	1860	3635	1800	1975	3775	1875	2520	4395
1270P		1855	1885	3740	1880	2000	3880	1955	2545	4500
1270T		1780	1875	3655	1810	1990	3800	1885	2535	4420
1180	Sedan Pickup 6-cylinder	1885	1705	3590	1905	1825	3730	2120	2280	4400
1180P		1960	1735	3695	1985	1850	3835	2200	2305	4505
1280	Sedan Pickup 8-cylinder	1870	1710	3580	1895	1825	3720	2110	2280	4390
1280P		1950	1735	3685	1975	1850	3825	2195	2305	4500
1280T		1875	1725	3600	1905	1840	3745	2120	2295	4415

1500-1600 SERIES BEL AIR

1511	2-Door Sedan 6-cylinder	1870	1645	3515	1885	1790	3675	2215	2360	4575
1511P		1950	1670	3620	1965	1815	3780	2295	2385	4680
1611	2-Door Sedan 8-cylinder	1860	1650	3510	1875	1795	3670	2205	2365	4570
1611P		1940	1680	3620	1955	1825	3780	2285	2395	4680
1611T		1870	1665	3535	1885	1810	3695	2210	2385	4595
1519	4-Door Sedan 6-cylinder	1895	1710	3605	1905	1855	3760	2235	2425	4660
1519P		1975	1735	3710	1985	1880	3865	2315	2450	4765
1619	4-Door Sedan 8-cylinder	1895	1720	3615	1910	1865	3775	2240	2435	4675
1619P		1975	1745	3720	1990	1890	3880	2320	2460	4780
1619T		1905	1735	3640	1920	1880	3800	2250	2450	4700
1539	4-Door Sport Sedan 6-cylinder	1905	1715	3620	1920	1860	3780	2170	2360	4530
1539P		1985	1740	3725	1995	1890	3885	2250	2385	4635
1639	4-Door Sport Sedan 8-cylinder	1895	1735	3630	1915	1875	3790	2165	2375	4540
1639P		1975	1755	3735	1990	1905	3895	2245	2400	4645
1639T		1905	1750	3655	1920	1895	3815	2175	2390	4565

1700-1800 SERIES IMPALA

1719	4-Door Sedan 6-cylinder	1920	1705	3625	1930	1850	3780	2260	2420	4680
1719P		1995	1735	3730	2010	1880	3890	2340	2450	4790
1819	4-Door Sedan 8-cylinder	1900	1720	3620	1915	1865	3780	2245	2435	4680
1819P		1980	1745	3725	1995	1890	3885	2325	2460	4785
1819T		1910	1735	3645	1925	1880	3805	2255	2450	4705
1737	2-Door Sport Coupe 6-cylinder	1900	1670	3570	1915	1810	3725	2215	2260	4475
1737P		1980	1695	3675	1995	1840	3835	2295	2290	4585
1837	2-Door Sport Coupe 8-cylinder	1890	1685	3575	1905	1830	3735	2200	2285	4485
1837P		1970	1715	3685	1985	1860	3845	2280	2315	4595
1837T		1895	1705	3600	1910	1850	3760	2210	2300	4510
1739	4-Door Sport Sedan 6-cylinder	1930	1735	3665	1940	1885	3825	2195	2380	4575
1739P		2010	1765	3775	2020	1910	3930	2275	2405	4680
1839	4-Door Sport Sedan 8-cylinder	1920	1750	3670	1935	1895	3830	2185	2395	4580
1839P		2000	1780	3780	2015	1925	3940	2265	2425	4690
1839T		1925	1770	3695	1940	1915	3855	2190	2415	4605

10-15-58 • Revised 3-23-59

10-GENERAL

1959 CHEVROLET PASSENGER CAR

17-1800 SERIES IMPALA (CON'T.)

1767	Convertible 6-cylinder	1945	1715	3660	1955	1860	3815	2255	2310	4565
1767P		2020	1745	3765	2035	1890	3925	2335	2340	4675
1867	Convertible 8-cylinder	1935	1715	3650	1950	1860	3810	2250	2310	4560
1867P		2020	1740	3760	2035	1885	3920	2330	2340	4670
1867T		1945	1730	3675	1960	1875	3835	2260	2325	4585

1100-1200 SERIES BROOKWOOD

VEHICLE TYPE		SHIPPING WEIGHT			CURB WEIGHT			LOADED WEIGHT		
Model	Description	Front	Rear	Total	Front	Rear	Total	Front	Rear	Total
1115	2-Door Station Wagon 6 cyl.	1805	2065	3870	1830	2180	4010	2150	2760	4910
1115P		1885	2090	3975	1910	2205	4115	2230	2786	5015
1215	2-Door Station Wagon 8 cyl.	1895	2065	3860	1825	2175	4000	2145	2755	4900
1215P		1875	2090	3965	1905	2205	4110	2225	2785	5010
1215T		1805	2080	3885	1830	2195	4025	2150	2775	4925
1135	4-Door Station Wagon 6 cyl.	1835	2120	3955	1860	2235	4095	2180	2815	4995
1135P		1910	2150	4060	1935	2265	4200	2260	2840	5100
1235	4-Door Station Wagon 8 cyl.	1815	2140	3955	1840	2255	4095	2165	2830	4995
1235P		1895	2165	4060	1920	2280	4200	2240	2860	5100
1235T		1825	2155	3980	1850	2270	4120	2170	2850	5020

1500-1600 SERIES PARKWOOD

1535	4-Door Station Wagon 6 cyl.	1840	2125	3965	1865	2240	4105	2195	2810	5005
1535P		1915	2155	4070	1940	2270	4210	2270	2840	5110
1635	4-Door Station Wagon 8 cyl.	1835	2135	3970	1860	2250	4110	2190	2820	5010
1635P		1915	2160	4075	1940	2275	4215	2270	2845	5115
1635T		1840	2150	3990	1870	2265	4135	2200	2835	5035

1500-1600 SERIES KINGSWOOD

1545	4-Door Station Wagon 6 cyl. *	1815	2200	4015	1845	2320	4165	2070	3445	5515
1545P		1905	2225	4130	1925	2350	4275	2150	3475	5625
1645	4-Door Station Wagon 8 cyl. *	1820	2195	4015	1845	2320	4165	2070	3445	5515
1645P		1900	2220	4120	1925	2345	4270	2150	3470	5620
1645T		1830	2210	4040	1845	2335	4180	2075	3460	5535

1700-1800 SERIES NOMAD

1735	4-Door Station Wagon 6 cyl.	1845	2140	3985	1875	2250	4125	2200	2825	5025
1735P		1930	2160	4090	1955	2275	4230	2275	2855	5130
1835	4-Door Station Wagon 8 cyl.	1840	2135	3975	1865	2250	4115	2185	2830	5015
1835P		1920	2160	4080	1945	2275	4220	2265	2855	5120
1835T		1845	2150	3995	1875	2265	4140	2195	2845	5040

SHIPPING WEIGHT: The weight of the basic vehicle with all regular equipment and with grease and oil where required. It does not include the weight of gasoline and water.

CURB WEIGHT: The weight of the empty vehicle ready to drive. It is the shipping weight plus the weights of gasoline and water. For the weight of gasoline add 105 pounds to the sedan delivery, sedan pickup, and station wagons except the 9 passenger models. Add 111 to the 9 passenger station wagon, 123 to all other models. For the weight of water add 35 pounds to the 6 cyl. models, 37 pounds to the 283 V-8 models, and 44 pounds to the 348 V-8 models.

LOADED WEIGHT: The curb weight of the basic vehicle plus a maximum of 150 pounds for each passenger.

Example:

Model 1119 (6 passenger) ----- 3760+900 = 4660

PERFORMANCE WEIGHT: The curb weight of the lowest priced 4-door sedan with regular equipment plus 600 pounds for passengers.

Example:

Model 1119 ----- 3760+600 = 4360

Note: Eight cylinder engine weights shown are for the standard 283 cu. in. V-8. For the optional 348 cu. in. V-8 add 145 pounds to front and total shipping weights, 152 pounds (engine weight plus water) to front and total curb and loaded weights.

P - Powerglide; T - Turboglide * - 9 passenger

TAXI-CAB EQUIPMENT (RPO 330)

MODEL APPLICATION: 4-Door Sedans
 Biscayne 1119 (6 cyl.) & 1219 (V8)
 Bel Air 1519 (6 cyl.) & 1619 (V8)

BODY EQUIPMENT

INTERIOR TRIM

Biscayne
 Standard ----- Cloth/vinyl, gray
 Optional ----- All vinyl, gray
 Bel Air
 Standard ----- Cloth/vinyl, gray
 Optional ----- All vinyl, gray

FLOORS, FRONT AND REAR

Covering ----- Waterproof asphalt im-
 pregnated paper felt, .125 minimum thickness.
 Mats ----- Black rubber (no spatter
 design) .125 minimum thickness. Styling identical
 to regular production including reinforcing patch
 under accelerator pedal. Regular production jute
 backing deleted.

SEAT CUSHIONS AND BACKRESTS

Construction, front and rear ----- Heavy duty
 "S" wire springs, reinforced.

DOORS, FRONT AND REAR

Jamb switches (dome lamp) ----- Furnished on all
 four doors (front jamb switches regular production
 on Bel Air models).
 Armrests ----- Rear armrests
 furnished on Biscayne models (regular production
 on Bel Air models).
 Glass (rolling only) ----- Safety solid plate "Tuflex"
 Rear door hinges ----- 80° wide opening
 type (regular production - 64°).

INSTRUMENT PANEL

Trim molding ----- Imprinted ignition
 lock positions "ACC" - "OFF" "ON" "START"
 Door warning lamp
 Lens ----- Red plastic, 1.125 dia.
 Bracket ----- Bright metal
 Location ----- Under instrument panel,
 left of steering column.
 Switch ----- All door jambs

CHASSIS EQUIPMENT

WHEELS

Type ----- Short spoke disc
 Size ----- 15 x 5K

FUEL TANK (LPO 1151A)

Capacity (gal) ----- 22

TIRES

Type ----- Tubeless, blackwall, rayon
 Size ----- 6.70 x 15-4 pr

SUSPENSION

Coil Springs
 Type ----- Heavy duty
 Front
 6 Cylinder models
 Part number ----- 3746853
 Capacity at ground ----- 1130
 V8 models
 Part number ----- 3752906
 Capacity at ground ----- 1175

Rear

All models
 Part number ----- 3758764
 Capacity at ground ----- 1315

Wheel Bearings

Type
 Front, inner & outer -- Heavy duty, tapered roller
 Rear ----- Heavy duty, roller

Spherical Joints, Front

Type ----- Metal lined

Lower Control Arm Bushings, Rear

Type ----- Heavy duty; inner and outer metal
 sleeves with rubber insert

Shock Absorbers

Type ----- Heavy duty
 Piston Diameter ----- 1.625
 Piston Travel
 Front ----- 4.94
 Rear ----- 8.43

ENGINE EQUIPMENT

ALL MODELS

Clutch Lever Shaft ----- Lubrication fitting
 provided
 Ignition Switch ----- "Accessory" position
 provided in place of "Lock"

SIX CYLINDER MODELS

Spark Plugs ----- AC 46
 Distributor ----- Positive ground
 via wire to coil bracket
 Clutch ----- 11" heavy duty (see
 Engine & Clutch, Page 41)
 Carburetor
 Model
 3-speed ----- 7013955
 Powerglide ----- 7013956

POLICE CAR EQUIPMENT

MODEL APPLICATION: 2-Door Sedan - Biscayne 1111 (6 cyl.)
 - Biscayne 1211 (V8)
 4-Door Sedan - Bel Air 1519 (6 cyl.)
 - Bel Air 1619 (V8)
 4-Door Station Wagon (6 Pass) - Brookwood 1135 (6 cyl.)
 Brookwood 1235 (V8)

BODY EQUIPMENT
 (LPO 1105)

INTERIOR TRIM

Biscayne
 Standard ----- Cloth/vinyl, gray
 Optional ----- All vinyl, gray
Bel Air
 Standard ----- Cloth/vinyl, gray
 Optional ----- All vinyl, gray
Brookwood ----- All vinyl, gray

FLOORS

Covering
 Front, all models ----- Waterproof asphalt impregnated paper felt, .125 minimum thickness.
 Rear, sedans only ----- Same as front
Mats
 Front, all models ----- Black rubber (no spatter design) .125 minimum thickness. Styling identical to regular production including reinforcing patch under accelerator pedal. Regular production jute backing deleted.
 Rear, sedans only ----- Same as front except reinforcing patch is omitted.

SEAT CUSHIONS AND BACKRESTS

Front, all models ----- Heavy duty "S" wire springs, reinforced.
 Rear, sedans only ----- Same as front

SUNSHADE, R.H.

Regular Production ----- Bel Air models; provided on Biscayne & Brookwood models

CHASSIS EQUIPMENT
 (LPO 1108)

WHEELS

Type ----- Short spoke disc
 Size ----- 15x5K

TIRES

Type ----- Tubeless, blackwall rayon
 Size
 Sedans ----- 6.70 x 15-4 pr
 Station wagons ----- 6.70 x 15-6 pr

SUSPENSION

Coil Springs, Front
 Capacity at ground ----- 1150
 Type ----- Heavy duty
Shock Absorbers, Front & Rear
 Type ----- Heavy duty
 Piston Diameter ----- 1.625
 Piston Travel
 Front ----- 4.94
 Rear ----- 8.43
Spherical Joints, Front
 Type ----- Metal lined
Lower Control Arm Bushings, Rear
 Type ----- Heavy duty
Front Stabilizer Bar
 V8 & station wagons ----- Regular production
 6 cyl. sedans ----- Provided

WHEEL BEARINGS

Front, inner and outer - Heavy duty, tapered roller
 Rear ----- Heavy duty, roller

BRAKES

Lining
 Material ----- Sintered iron, segmented
 Method of attachment ----- Riveted
 No. of segments per shoe
 Front
 Primary ----- Six
 Secondary ----- Twelve
 Rear
 Primary ----- Six, Secondary ----- Ten

AIR CONDITIONING EQUIPMENT (FOA 110)

COMPRESSOR

Make ----- Frigidaire
 Type ----- 5 cylinder reciprocating
 Clutch Coil, Ohms (@80°F) ----- 4.18-4.28
 Amperes (@ 80 F) ----- 2.86@12 volts
 Oil. Type ----- Frigidaire 525 viscosity
 Capacity (Oz) ----- 13
 Pulley Diameter (nominal) ----- 5.31
 Ratio (compressor to engine) ----- 1.25:1
 Drive ----- Rotating socket plate

REFRIGERANT

Type ----- Freon 12
 Capacity (lb) ----- 4.5

CONDENSER

Type ----- Tube and fin
 Material ----- Steel brazed with cadmium
 or zinc plate
 Location ----- Mounted in front of radiator
 to radiator support

RECEIVER-DEHYDRATOR

Material ----- Heavy gage drawn steel tube
 Location ----- Right side of condenser
 Function, Receiver ----- Reservoir for storage
 of high pressure liquid
 Dehydrator ----- Accumulate moisture and
 trap foreign material

EVAPORATOR

Location ----- Right cowl plenum chamber
 Core Size (Sq. In) ----- 125.0
 Cooling and Heating Coil Material ----- Copper
 tubes and button fins

TEMPERATURE REGULATOR

Type ----- Hot gas by-pass valve
 Location ----- On compressor

PRESSURE RELIEF VALVE

Opens (approx) ----- 440-450 psi
 Closes (approx) ----- 300 psi

BLOWER MOTOR

Volts ----- 14
 Amperes (cold) ----- 14.3 (max)
 Speed (cold) ----- 3550 rpm

ENGINE IDLE SETTING

Auto Trans in Drive ----- 450 rpm
 Std Trans in Neutral ----- 450 rpm
 Fast Idle "Full On", Compressor Engaged and Trans-
 mission in Neutral ----- 900 rpm

FRONT SPRINGS

For detailed information see Page 3, Chassis Section

SHOCK ABSORBERS, FRONT

Model Number ----- F539G 63A
 Piston Diameter and Travel ----- 1.25; 4.9375

CRANKSHAFT PULLEY

Type ----- Dual groove

WATER PUMP AND FAN PULLEY

Type ----- Dual groove

FAN

Number of Blades ----- 5, staggered
 Diameter ----- 18.00

FAN BLADE CLUTCH

Type ----- Temperature modulated viscous drive
 Fan speed limited at ----- 3100 rpm

COMPRESSOR BELT

Pitch Line Length, 283 Cu In V-8 ----- 58.50
 348 Cu In V-8 ----- 60.00

GENERATOR

Model ----- 1102114
 Amperes ----- 35

VOLTAGE AND CURRENT REGULATOR

Model, 283 Cu In V-8 ----- 1119002
 348 Cu In V-8 ----- 1119235

ENGINES AND CLUTCHES

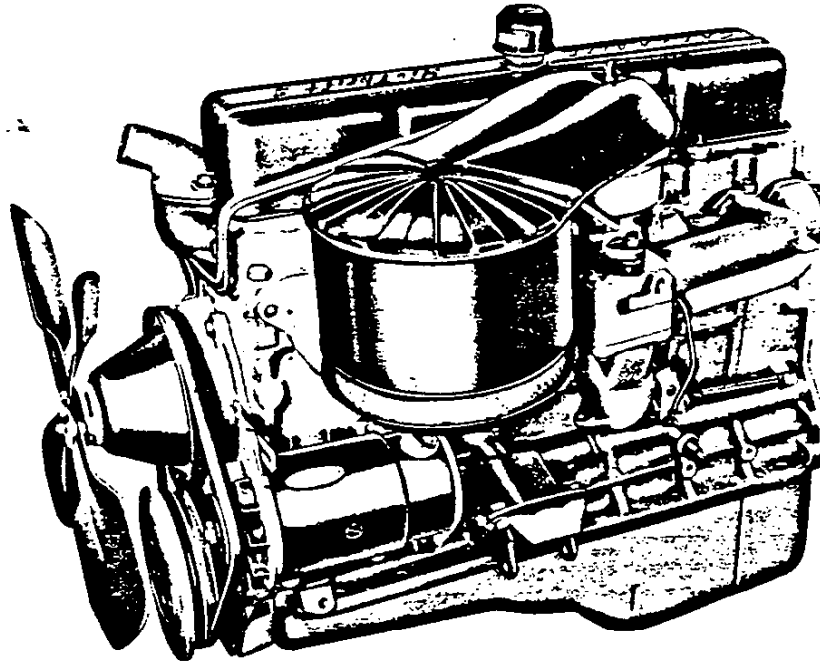

HI-THRIFT SIX CYLINDER ENGINE

HI-THRIFT SIX CYLINDER ENGINE	2
283 CUBIC INCH V-8 ENGINE	10
348 CUBIC INCH V-8 ENGINE	26
CLUTCHES	41

HI-THRIFT SIX CYLINDER ENGINE

GENERAL DATA

Engine		Conventional	Powerglide
Piston displacement (cu. in.)		235.5	
Type		Valve-in-head	
Number of cylinders		6	
Bore and stroke (nominal)		3.56 x 3.94	
Compression ratio		8.25:1	
Taxable (SAE) horsepower		30.4	
Idling speed (RPM)		475 in neutral	425 in drive
Compression press. (PSI) @ cranking speed, engine hot		130	
Dry weight (pounds)	Engine and clutch	605	555
	With transmission	670	775
Lubrication		Full pressure	
Power plant mounting		Three point mounting, two front and one rear; combination compression and shear type	
Measurements (inches)	Fan to rear of clutch housing	41.26	36.37
	Front of cylinder block to rear of clutch housing	34.26	29.37
	Length of cylinder block	27.95	
	Top air cleaner to bottom oil pan	29.30	
	Crankcase vent tube to air cleaner (width)	25.75	

ADVERTISED MAXIMUM ENGINE PERFORMANCE

Engine		Conventional and Powerglide
Carburetor		Single-barrel
Brake horsepower	Gross	135@ 4000 RPM
	Net	115@ 3600 RPM
Torque (lb. ft.)	Gross	217@ 2000-2400 RPM
	Net	197@ 1200-2000 RPM

ENGINE SPEED AND PISTON TRAVEL

Transmission	3-Speed	3-Speed with Overdrive		Powerglide
		O. D. locked out	O. D. locked in	
Rear axle ratio	3.55:1	3.70:1		3.36:1
Tire size	7.50 x 14-4\$			
Crankshaft revolutions per mile	2801.0	2919.3	2043.5	2651.0
Crankshaft RPM@ 1 MPH	Low and rev.	137.3	143.2	100.2(143.2 Rev)
	Second	78.5	81.8	57.3
	Third \ddagger	46.7	48.7	34.1
Piston travel (ft./mile)	1837.5	1915.1	1340.5	1739.1

\ddagger - Also known as N/V factor

+ - Overdrive transmission

\$ - 8.00 x 14-4 pr tires standard on 1767 and station wagon models.

ADVERTISED CAR PERFORMANCE

Transmission	3-Speed	3-Speed with Overdrive (RPO 315)		Powerglide (RPO 313)
		Locked out	Locked in	
Model		1519		
Performance weight (pounds) +	4360	4395		4465
Pounds/gross horsepower	32.30	32.56		33.07
Pounds/cu. in. displacement	18.51	18.66		18.96
Gross horsepower/cu. in. displacement		.573		
Power displacement (cu. ft./mile) %	189.7	197.7	138.4	179.5**
Displacement factor (cu. ft./ton mile) #	87.0	90.0	63.0	80.4**

** - Data computed assuming zero slippage in torque converter.

+ - Curb weight plus 600 # (four 150 # passengers).

% - $\frac{\text{Crankshaft revolutions per mile} \times \text{piston displacement}}{1728}$

- Power displacement divided by performance weight in tons.

HI-THRIFT SIX CYLINDER ENGINE - Continued

HI-THRIFT SIX CYLINDER ENGINE

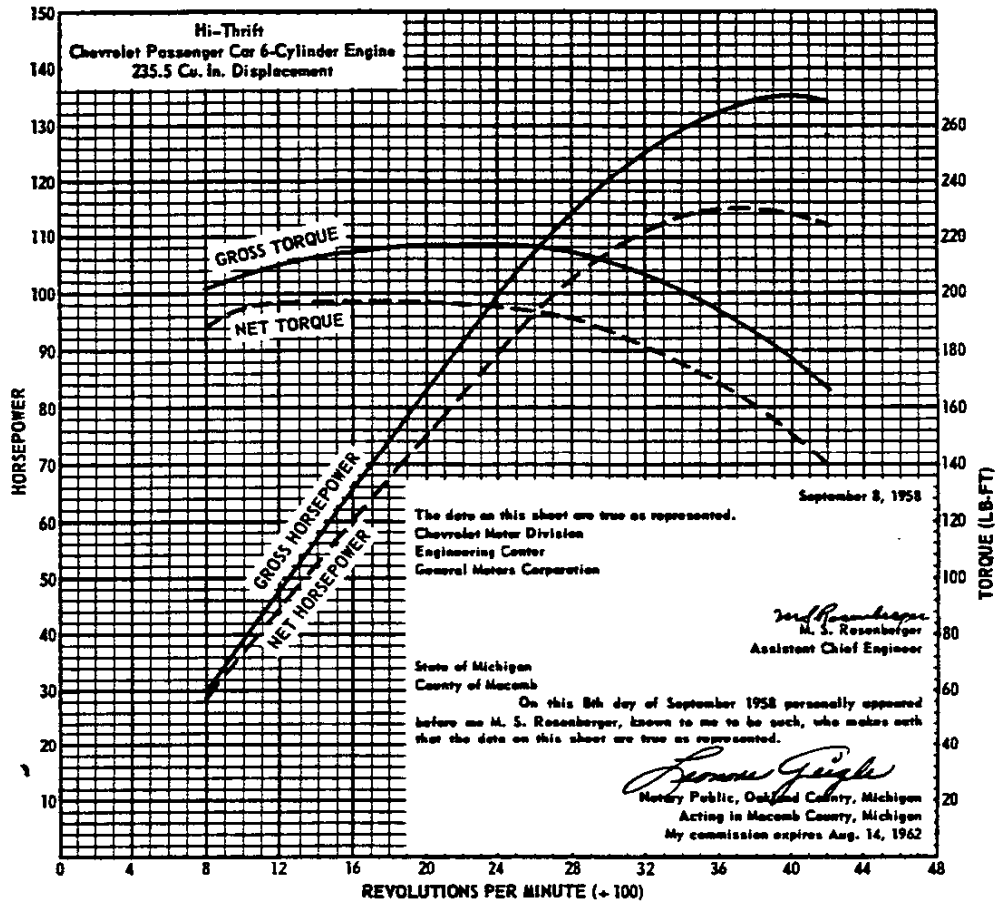

The engine performance curves shown on this sheet are taken from Chevrolet engine test report 18334-20. They represent the full throttle performance of a new Hi-Thrift 135 six cylinder passenger car engine with 235.5 cubic inch displacement, as obtained from dynamometer test data corrected to standard barometric pressure 29.92 inches of mercury and the standard temperature of 60° F.

GROSS POWER and TORQUE were obtained in a regular dynamometer test with the dynamometer exhaust system, no fan, generator not charging, and optimum spark advance.

10-15-58
 4-ENGINES AND CLUTCHES

NET POWER and TORQUE were obtained from a dynamometer test simulating actual operating conditions when the engine is in its vehicle. It includes the use of the regular muffler and pipes, the fan in operation and automatic spark advance. The generator is not charging.

1959 CHEVROLET PASSENGER CAR

HI-THRIFT SIX CYLINDER ENGINE - Continued

CONNECTING RODS - Cont'd

Bearings - Cont'd

Clearance	.0007-.0027
End play	.005-.010
Inside diameter	2.3132
Projected area (Sq. In.)	2.332

VALVES

Inlet

Material	High alloy steel (8645)
Stem to guide clearance	.0010-.0027
Lift	.3275

Exhaust

Material	High alloy steel (21-4N)
Stem to guide clearance	.0010-.0027
Lift	.3275

VALVE SPRINGS

Length and Pressure

Valve closed-inlet & exhaust	1.858 @ 62-68 lb.
Valve opened-inlet & exhaust	1.528 @ 158-168 lb.
Free length-inlet & exhaust	2.16
Valve spring dampers	None

VALVE TIMING (Theoretical)

Intake

Opens	16° BTC
Closes	48° ABC

Exhaust

Opens	46° 30' BBC
Closes	17° 30' ATC

PISTONS

Material ----- Cast alloy aluminum

Type	Flat head, controlled expansion
Weight	18.08 oz.
Top Land Clearance	.033-.042
Skirt Clearance	.0006-.0010
Compression Ring Groove Depth	.199-.205
Oil Ring Groove Depth	.199-.205

PISTON PINS

Material	Chromium steel
Type	Locked in rod
Length	3.168-3.198
Diameter	.8660-.8665
Clearance	.00015-.00025
Direction of Offset	Major thrust side

COMPRESSION RINGS

Type	Upper and lower ----- Thick wall, inside bevel or counterbore
Material	Cast alloy iron
Coating	Wear resistant
Width	.0930-.0935
Wall Thickness	.168-.178
Gap	.007-.017

OIL RINGS

Type	Multi-piece (two chrome rails and one spacer)
Material	----- Steel
Rails	----- Steel
Spacer	----- Stainless Steel
Coating	Upper & lower rails chrome plated O.D.
Width	.224-.231
Gap (rails)	.015-.055
Wall Thickness (rails)	.150-.156

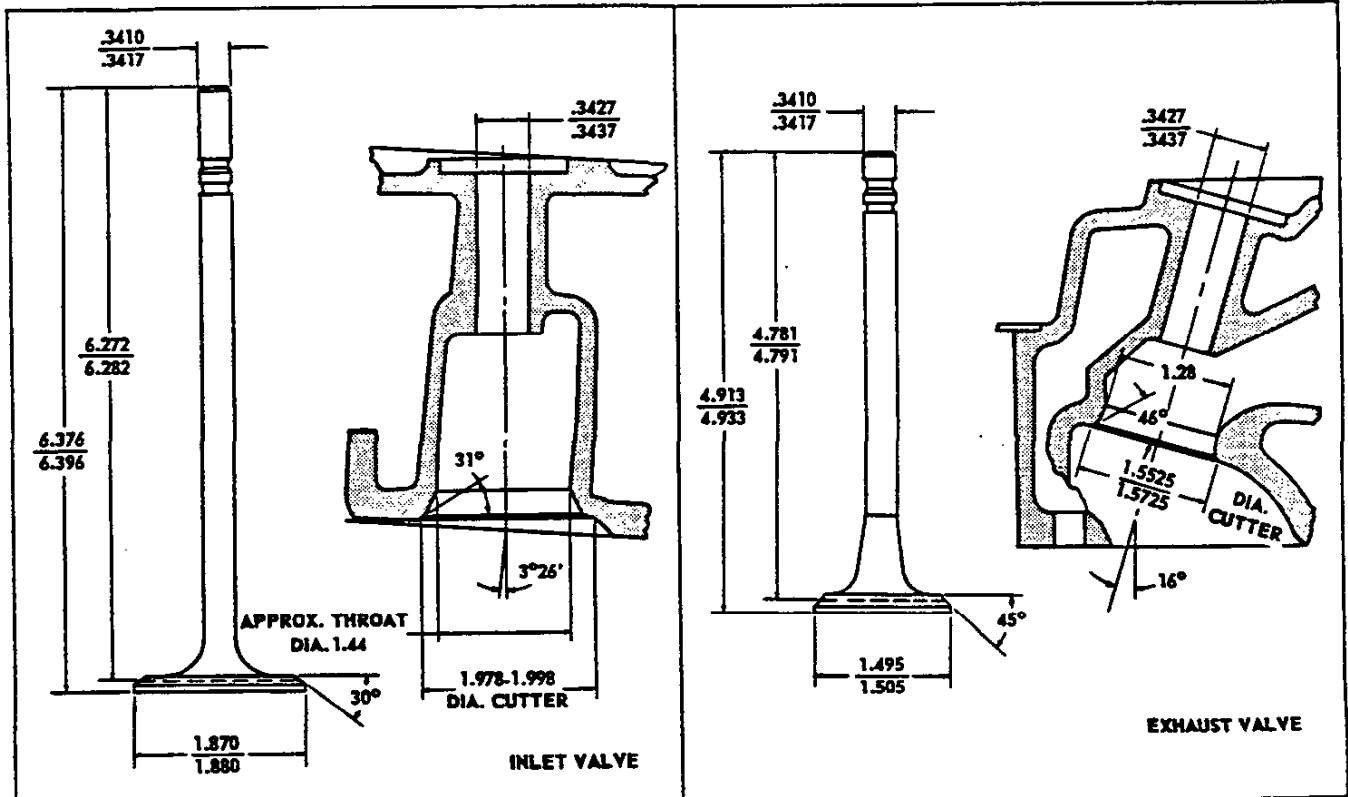

10-15-58

6-ENGINES AND CLUTCHES

1959 CHEVROLET PASSENGER CAR

LUBRICATION SYSTEM

GENERAL

Type ----- Controlled, full pressure
Main Bearings ----- Pressure
Connecting Rods ----- Pressure
Piston Pins ----- Splash
Cylinder Walls ----- Pressure, jet-cross sprayed
Camshaft Bearings ----- Pressure
Hydraulic Lifters ----- Pressure
Timing Gear ----- Nozzle sprayed

OIL PUMP

Type ----- Gear
Normal Oil Pressure ----- 35 PSI @ 2000 RPM
Intake Type ----- Fixed
Capacity (GPM @ engine RPM) 4.01-4.22 @ 1170-1200

CRANKCASE CAPACITY (quarts)

Dry ----- 5.5
Refill ----- 5.0

OIL FILTER (RPO 237)

Make and Type ----- AC, partial flow
Capacity (dry) ----- 1 qt.
Replacement Type ----- Element

OIL PRESSURE GAUGE

Type ----- Electric

LUBRICANT GRADES AND TEMPERATURES

Temperature	Grade
32°F and Above	SAE 20W, SAE 20, SAE 10W-30
0°F and Above	SAE 10W or SAE 10W-30
Below 0°F	SAE 5W or SAE 5W-20

CRANKCASE VENTILATION

Type ----- Road draft

FUEL AND EXHAUST SYSTEM

FUEL TANK

Capacity (gallons)
Station Wagon and Sedan Delivery ----- 17*
All others ----- 20
Filler Location
Station Wagon and Sedan Delivery ----- Behind
LR quarter panel
All others ----- At center of body back lower
panel to rear of hinged license plate bracket

FUEL FILTER

In Fuel Tank ----- Screen
In Carburetor Inlet ----- Sintered bronze filter

FUEL GAUGE (Tank Unit)

Make and Type ----- AC, electric

FUEL PUMP ASSEMBLY

Make ----- AC
Type ----- Mechanical
Location ----- Lower right front corner of engine
Pressure Range ----- 3.50-4.50 PSI

*-9-passenger station wagon has 18 gal. capacity.

CARBURETOR

Make ----- Rochester Products
Model
Regular ----- 7013003
Powerglide ----- 7013000
Type ----- Single barrel, downdraft
SAE Flange Size ----- 1.50
Venturi Inside Diameter ----- 1.34
Choke ----- Automatic
Throttle Bore ----- 1.5625

AIR CLEANER

Type
Regular ----- Oil wetted
RPO 216 ----- Oil bath

EXHAUST SYSTEM

Type ----- Single, diffusion resonance
Muffler ----- Reverse flow
Exhaust Pipe Outside Diameter ----- 2.00
Tailpipe Inside Diameter ----- 1.81

COOLING SYSTEM

GENERAL

Type
Pressure, with full length water jackets around cylinders.

THERMOSTAT

Make ----- Harrison
Type ----- Pellet
Begins to Open @ ----- 167-172°F
Fully Opened @ ----- 192°F

RADIATOR

Make and Type ----- Harrison, tube on center
Core Constant and Thickness
Regular ----- .28 x .55 x 1.75
Powerglide ----- .25 x .55 x 1.75
Frontal Area ----- 390 sq in
Capacity,(quarts)
3-Speed transmission
Less heater ----- 17
With heater ----- 18
Powerglide transmission
Less heater ----- 16.5
With heater ----- 17.5

RADIATOR HOSE

Outlet, lower (radiator to water pump) ----- 1.75 I.D.
Inlet, upper (thermostat hsg. to rad.) ----- 1.50 I.D.

RADIATOR CAP

Type ----- Pressure
Valve Opens at ----- Approx. 13 PSI

WATER PUMP

Type ----- Centrifugal
Capacity ----- 55 GPM @ 4000 RPM
Drive ----- Fan belt
Bearing ----- Permanent lubricated double row ball

HI-THRIFT SIX CYLINDER ENGINE - Continued

COOLING SYSTEM - Continued

FAN

Number of Blades ----- 4, staggered
 Diameter ----- 17.62
 Ratio (fan to engine RPM) ----- .949:1

FAN AND GENERATOR BELT

Number Used ----- One
 Angle of "V" ----- 37°-44°
 Pitch Line Length ----- 40.50
 Width ----- .375
 Fan Pulley Size (pitch diameter) ----- 7.00

ELECTRICAL SYSTEM

GENERATOR

Make and Model ----- Delco-Remy, 1102096
 Type ----- Two brush, shunt wound
 Drive ----- By fan belt
 Pulley size ----- 2.88 P.D.
 Generator RPM/MPH ----- Approx. 107
 Maximum Generator Output RPM (Hot) ----- 2450
 Eng. RPM @ Max. Gen. Output ----- 1065
 Car MPH (high gear) @ Max. Gen. Output ----- 22.9
 Ratio (Generator to engine) ----- 2.30:1
 Rating:
 Amps ----- 30
 Volts ----- 12-15

OPTIONAL GENERATOR EQUIPMENT

35 Amp. (RPO 338) ----- 1102114
 40 Amp. (RPO 326) Medium duty ----- 1105123
 50 Amp. (RPO 378) Low cut-in ----- 1106985

BATTERY

Make and Model ----- Delco, 1980458
 Voltage Rating ----- 12
 Capacity ----- 53 amp hr. at 20 hr. rate
 Plates per Cell ----- 9
 Terminal Grounded ----- Negative
 Location ----- Front of engine compartment near radiator baffle

VOLTAGE AND CURRENT REGULATOR

Make and Model ----- Delco-Remy, 1119001
 Type ----- Vibrator
 Cutout Relay
 Closing voltage @ generator RPM - 11.8-13.5@1300
 Voltage Regulator
 Voltage ----- 13.8-14.8
 Current Regulator
 Amperes ----- 27-33

STARTING MOTOR

Make and Model ----- Delco-Remy, 1107652
 Rotation (Drive end view) ----- Clockwise
 Test Conditions ----- Engine at operating temperature
 No Load Test
 Amps ----- 49-76
 Volts ----- 10.6
 RPM ----- 6200-6900

10-15-58 • Revised 3-23-59
8-ENGINES AND CLUTCHES

Drive

Engagement type ----- Solenoid
 No. of teeth ----- 9
 Gear ratio (flywheel to starter) ----- 18.6:1
 Flywheel tooth face width ----- .4135

STARTING

Ignition Switch ----- 4 positions:
 Locked off, unlocked off, on, and start.

Starting Procedure

Turn ignition key to extreme right after placing shift lever in neutral and depressing clutch
 Powerglide models - Place selector lever in Park or Neutral

DISTRIBUTOR

Make and Model ----- Delco-Remy, 1112403
 Breaker Gap ----- .016-.021
 Cam Angle ----- 28°-35°
 Breaker Arm Tension ----- 19-23 oz.
 Spark Advance Data
 Centrifugal advance begins (RPM) ----- 450-750
 Centrifugal advance max. degrees @ RPM -----
 ----- 24°-28° @ 3500
 Vacuum advance begins (inches Hg) ----- 6
 Vacuum advance max. degrees @ inches Hg -----
 ----- 22 @ 15.5

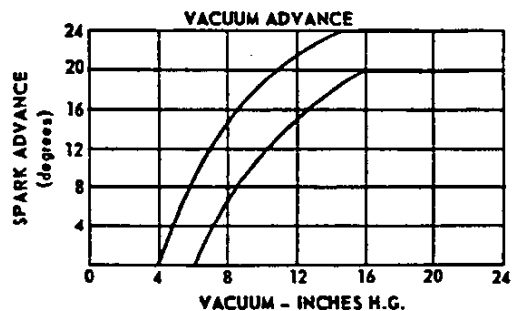
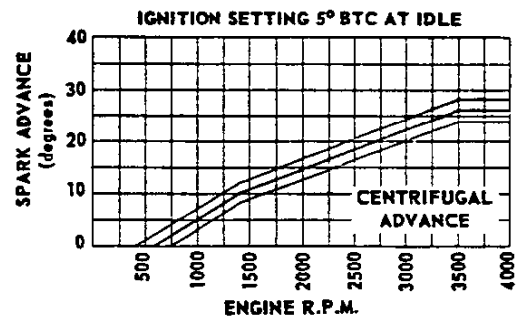

1959 CHEVROLET PASSENGER CAR

COIL
Make ----- Delco Remy
Model ----- 1115120
Amperes Drawn ----- 4.0 engine stopped, 1.8
engine idling (500 RPM)

IGNITION TIMING
Crankshaft Degrees (initial setting) ----- 5°BTC

Mark Location ----- On flywheel
Firing Order ----- 1-5-3-6-2-4

SPARK PLUG
Make and Model ----- AC, 44
Thread Size ----- 14mm
Gap ----- .033-.038
Torque ----- 25 lb. ft.

283 CUBIC INCH V-8 ENGINE

GENERAL DATA

Engine		Conventional	Powerglide	Turboglide
Piston displacement (cu. in.)		283		
Type		Valve-in-head		
Number of cylinders		8		
Bore and stroke (nominal)		3.875 x 3.000		
Compression ratio		8.5:1 @		
Taxable (SAE) horsepower		48		
Idling speed (RPM)		475 in neutral	450 in neutral	
Compression press. (PSI)@ cranking speed, engine hot		150**		
Dry weight (pounds)	Engine and clutch	605	610 ▽	545
	With transmission	665	700 ▽	770
Lubrication		Full pressure		
Power plant mounting		Three point mounting, two front and one rear; combination compression and shear type		
Measurements (inches)	Fan to rear of clutch housing	36.57	31.66	
	Front of cylinder block to rear of clutch housing	29.57	24.66	
	Length of cylinder block	23.28		
	Top air cleaner to bottom oil pan	29.54		
	Exhaust manifold to generator (width)	26.72		

ADVERTISED MAXIMUM ENGINE PERFORMANCE

Engine	Turbo-Fire	Super Turbo-Fire	Ramjet Fuel Injection	Ramjet Fuel Injection Special
Carburetor	2-barrel (Production)	4-barrel (RPO 410)	Fuel injection through nozzles at intake ports (RPO 578)	
Camshaft	Standard			Special
Brake horsepower	Gross	185@ 4600 RPM	230@ 4800 RPM	250@ 5000 RPM
	Net	150@ 4200 RPM	175@ 4400 RPM	225@ 4800 RPM
Torque (lb. ft.)	Gross	275@ 2400 RPM	300@ 3000 RPM	305@ 3800 RPM
	Net	245@ 24-2800 RPM	255@ 2800 RPM	280@ 3400 RPM

ENGINE SPEED AND PISTON TRAVEL

Transmission	3-Speed (Production)	Overdrive (RPO 315)		4-Speed (RPO 685)	Powerglide (RPO 313)*	Turboglide (RPO 302)*
		Locked out	Locked in			
Rear axle ratio	3.55:1	3.70:1		3.55:1	3.36:1	
Tire size	7.50 x 14-4 \$					
Crankshaft revolutions per mile	2801.0	2919.3	2043.5	2801.0	2651.0	
Crankshaft RPM @ 1 MPH	Low	115.3	143.2	100.2	102.7	80.4
	Reverse	130.8		143.2	105.5	80.4
	Second	71.5	81.8	57.3	77.5	
	Third				61.2	
	Direct †	46.7	48.7	34.1	46.7	44.2
Piston travel (ft/mile)	1400.5	1459.7	1021.8	1400.5	1325.5	

* - Data computed assuming zero slippage in torque converter.

** - 160 psi with 4-barrel carburetor and fuel injection with regular cam engines; 140 psi with fuel injection and special cam engine.

▽ - Overdrive transmission

@ - 9.5:1 on Super Turbo-Fire and Fuel Injection; 10.5:1 on Fuel Injection Special engine.

\$ - 8.00 x 14-4 tires standard on 1867, station wagon, Sedan Delivery and Sedan Pick-up.

† - Also known as N/V factor.

10-15-58 • Revised 3-23-59

10- ENGINES AND CLUTCHES

1959 CHEVROLET PASSENGER CAR

ADVERTISED CAR PERFORMANCE

3-Speed Transmission	ENGINE			
	Turbo-Fire	Super Turbo-Fire	Ramjet Fuel Injection	Ramjet Fuel Injection Special
Model	1619			
Performance weight (pounds) +	4375	4390	4420	4420
Pounds per gross horsepower	23.65	19.09	17.68	15.24
Pounds per cu. in. displacement	15.46	15.51	15.62	15.62
Gross horsepower per cu. in. displacement	.654	.813	.883	1.025
Power displacement (cu. ft. mile) @	227.9	227.9	227.9	227.9
Displacement factor (cu. ft./ton mile) #	104.2	103.8	103.1	103.1

3-Speed w/Overdrive Transmission \$

Performance weight (pounds) +	4415	4430		
Pounds per gross horsepower	23.86	19.26		
Pounds per cu. in. displacement	15.60	15.65		
Gross horsepower per cu. in. displacement	.654	.813		
Power displacement (cu. ft./mile) @	166.3	166.3		
Displacement factor (cu. ft./ton mile) #	753.3	75.1		

4-Speed Transmission

Performance weight (pounds) +			4435	4435
Pounds per gross horsepower			17.74	15.29
Pounds per cu. in. displacement			15.67	15.67
Gross horsepower per cu. in. displacement			.883	1.025
Power displacement (cu. ft./mile) @			227.9	227.9
Displacement factor (cu. ft./ton mile) #			102.8	102.8

Powerglide Transmission *

Performance weight (pounds) +	4480	4495	4525	
Pounds per gross horsepower	24.22	19.54	18.10	
Pounds per cu. in. displacement	15.83	15.88	15.99	
Gross horsepower per cu. in. displacement	.654	.813	.883	
Power displacement (cu. ft./mile) @	215.7	215.7	215.7	
Displacement factor (cu. ft./ton mile) #	96.3	96.0	95.3	

Turboglide Transmission *

Performance weight (pounds) +	4400	4415	4445	
Pounds per gross horsepower	23.62	19.20	17.78	
Pounds per cu. in. displacement	15.55	15.60	15.71	
Gross horsepower per cu. in. displacement	.654	.813	.883	
Power displacement (cu. ft./mile) @	215.7	215.7	215.7	
Displacement factor (cu. ft./ton mile) #	98.0	97.7	97.1	

* - Data computed assuming zero slippage in torque converter.

+ - Curb weight plus 600 lb. (weight of four 150 # passengers).

@ - Crankshaft revolutions per mile x piston displacement +2

1728

- Power displacement divided by performance weight in tons.

\$ - Overdrive locked in.

283 CUBIC INCH V-8 ENGINE - Continued

TURBO-FIRE 283 CUBIC INCH V-8 ENGINE

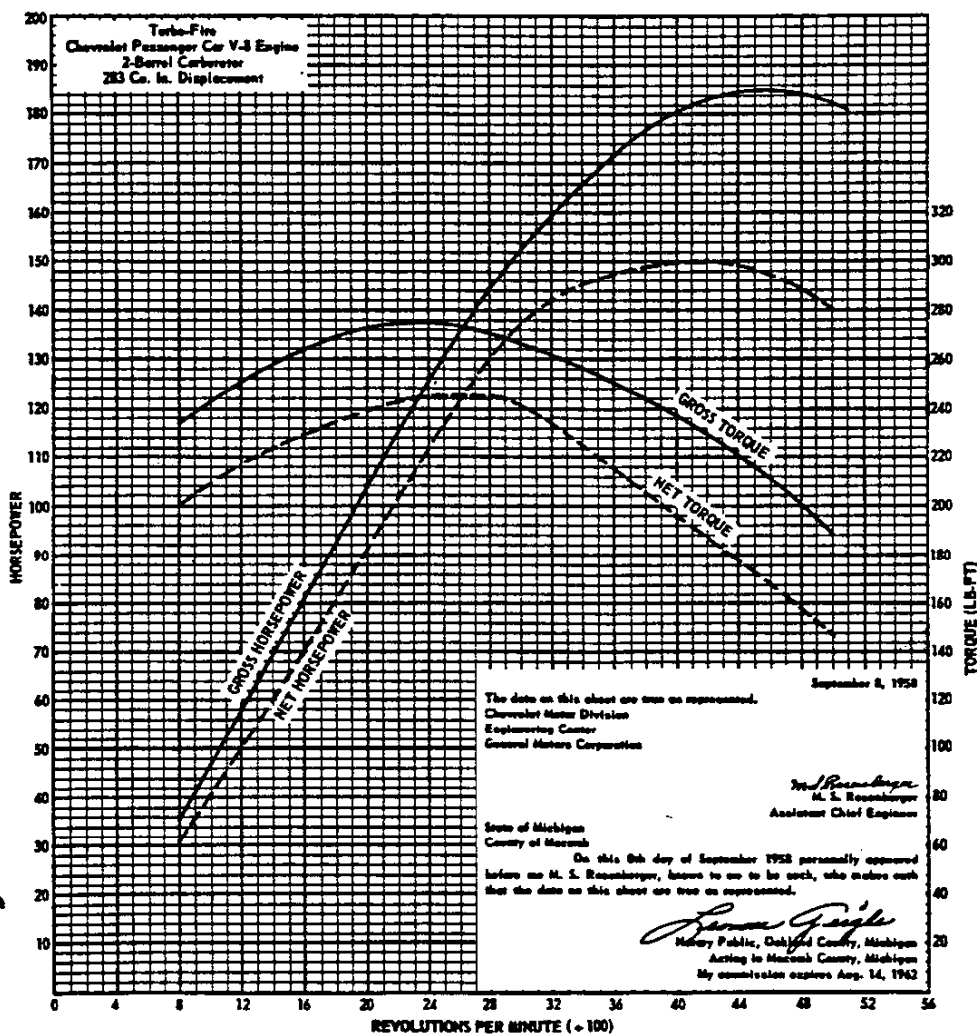

The engine performance curves shown on this sheet are taken from Chevrolet engine test report 17697-25. They represent the full throttle performance of a Turbo-Fire 283 Chevrolet passenger car engine with 283 cubic inch displacement, as obtained from dynamometer test data corrected to standard barometric pressure 29.92 inches of mercury and the standard temperature of 60°F.

GROSS POWER and TORQUE were obtained in a reg-10-15-58
12-ENGINES AND CLUTCHES

ular dynamometer test with the dynamometer exhaust system, no fan, generator not charging, and optimum spark advance.

NET POWER and TORQUE were obtained from a dynamometer test simulating actual operating conditions when the engine is in its vehicle. It includes the use of the regular muffler and pipes, the fan in operation and automatic spark advance. The generator is not charging.

1959 CHEVROLET PASSENGER CAR

SUPER TURBO-FIRE 283 CUBIC INCH V-8 ENGINE

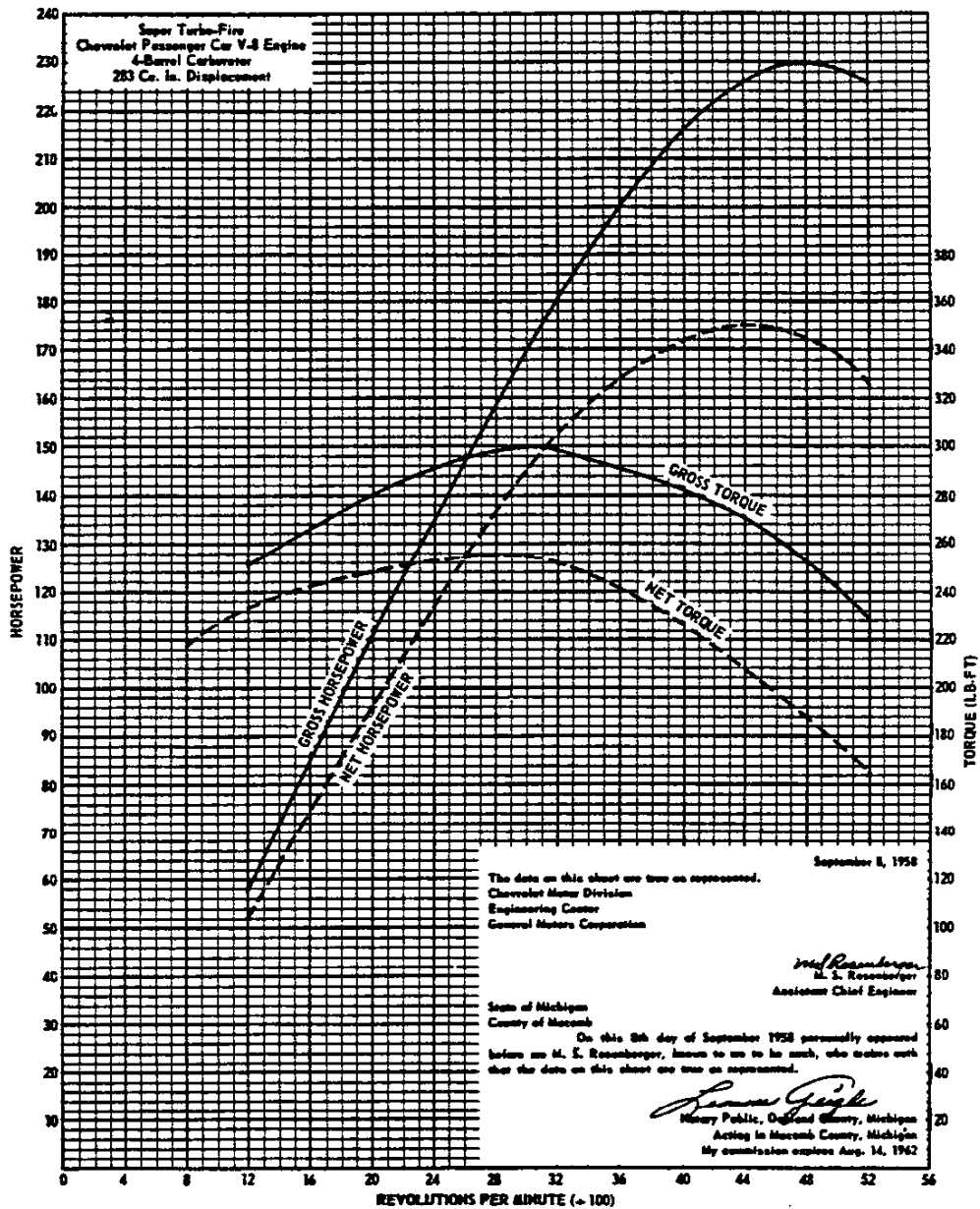

The engine performance curves shown on this sheet are taken from Chevrolet engine test report 18333-10. They represent the full throttle performance of a Super Turbo-Fire Chevrolet passenger car engine with 283 cubic inch displacement, as obtained from dynamometer test data corrected to standard barometric pressure 29.92 inches of mercury and the standard temperature of 60°F.

GROSS POWER and TORQUE were obtained in a regular dynamometer test with the dynamometer exhaust system, no fan, generator not charging, and optimum spark advance.

GROSS POWER and TORQUE were obtained in a regular dynamometer test with the dynamometer exhaust system, no fan, generator not charging, and optimum spark advance.

NET POWER and TORQUE were obtained from a dynamometer test simulating actual operating conditions when the engine is in its vehicle. It includes the use of the regular muffler and pipes, the fan in operation and automatic spark advance. The generator is not charging.

NET POWER and TORQUE were obtained from a dynamometer test simulating actual operating conditions when the engine is in its vehicle. It includes the use of the regular muffler and pipes, the fan in operation and automatic spark advance. The generator is not charging.

NET POWER and TORQUE were obtained from a dynamometer test simulating actual operating conditions when the engine is in its vehicle. It includes the use of the regular muffler and pipes, the fan in operation and automatic spark advance. The generator is not charging.

RAMJET FUEL INJECTION
283 CUBIC INCH V-8 ENGINE

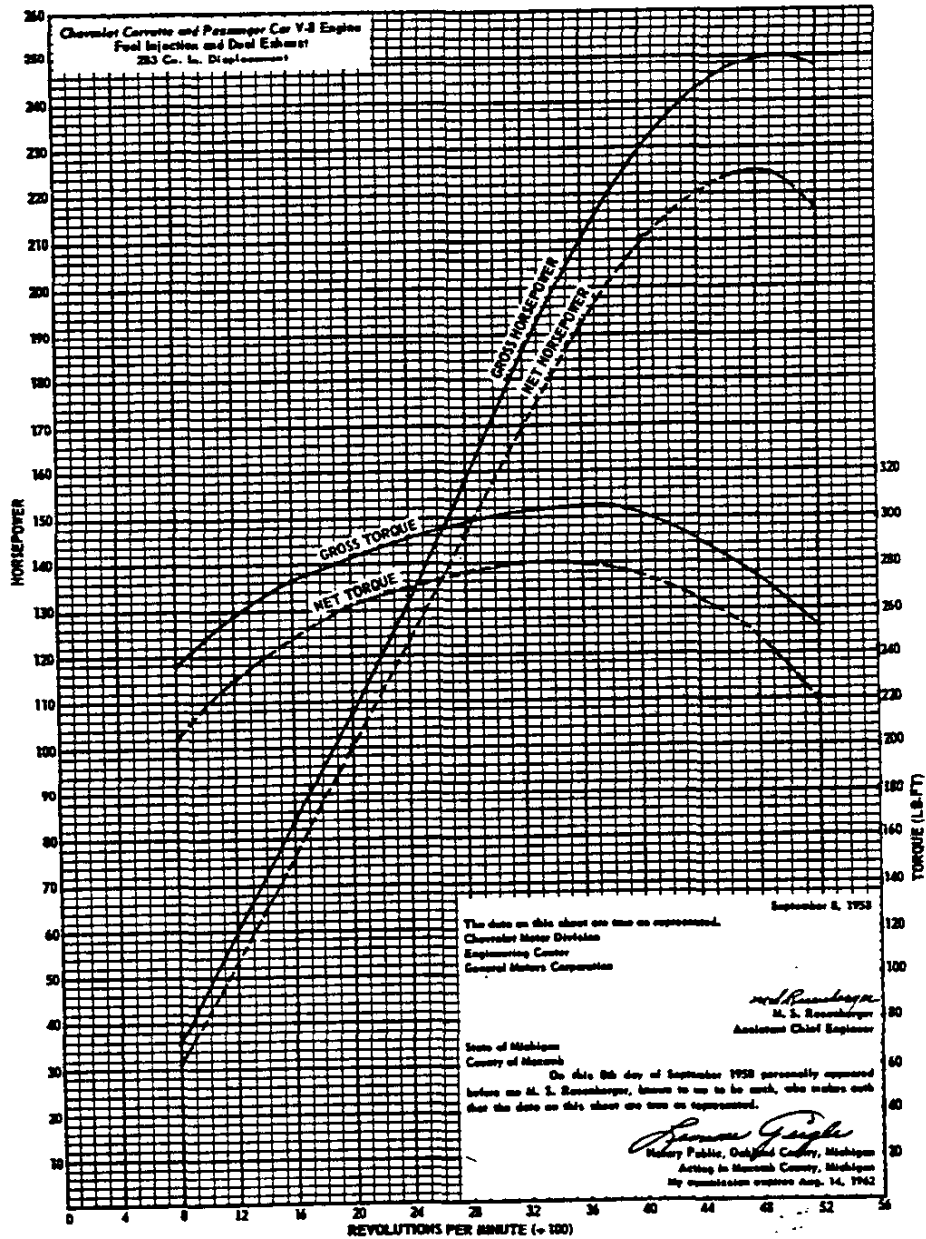

The engine performance curves shown on this sheet are taken from Chevrolet engine test report 17696-12. They represent the full throttle performance of a Chevrolet Corvette and passenger car V-8 engine with 283 cubic inch displacement, as obtained from dynamometer test data corrected to standard barometric pressure 29.92 inches of mercury and the standard temperature of 60°F.

GROSS POWER and TORQUE were obtained in a reg-10-15-58
14-ENGINES AND CLUTCHES

ular dynamometer test with the dynamometer exhaust system, no fan, generator not charging, and optimum spark advance.

NET POWER and TORQUE were obtained from a dynamometer test simulating actual operating conditions when the engine is in its vehicle. It includes the use of the regular mufflers and pipes, the fan in operation and automatic spark advance. The generator is not charging.

1959 CHEVROLET PASSENGER CAR

**RAMJET FUEL INJECTION
283 CUBIC INCH V-8 ENGINE
(With Special Camshaft)**

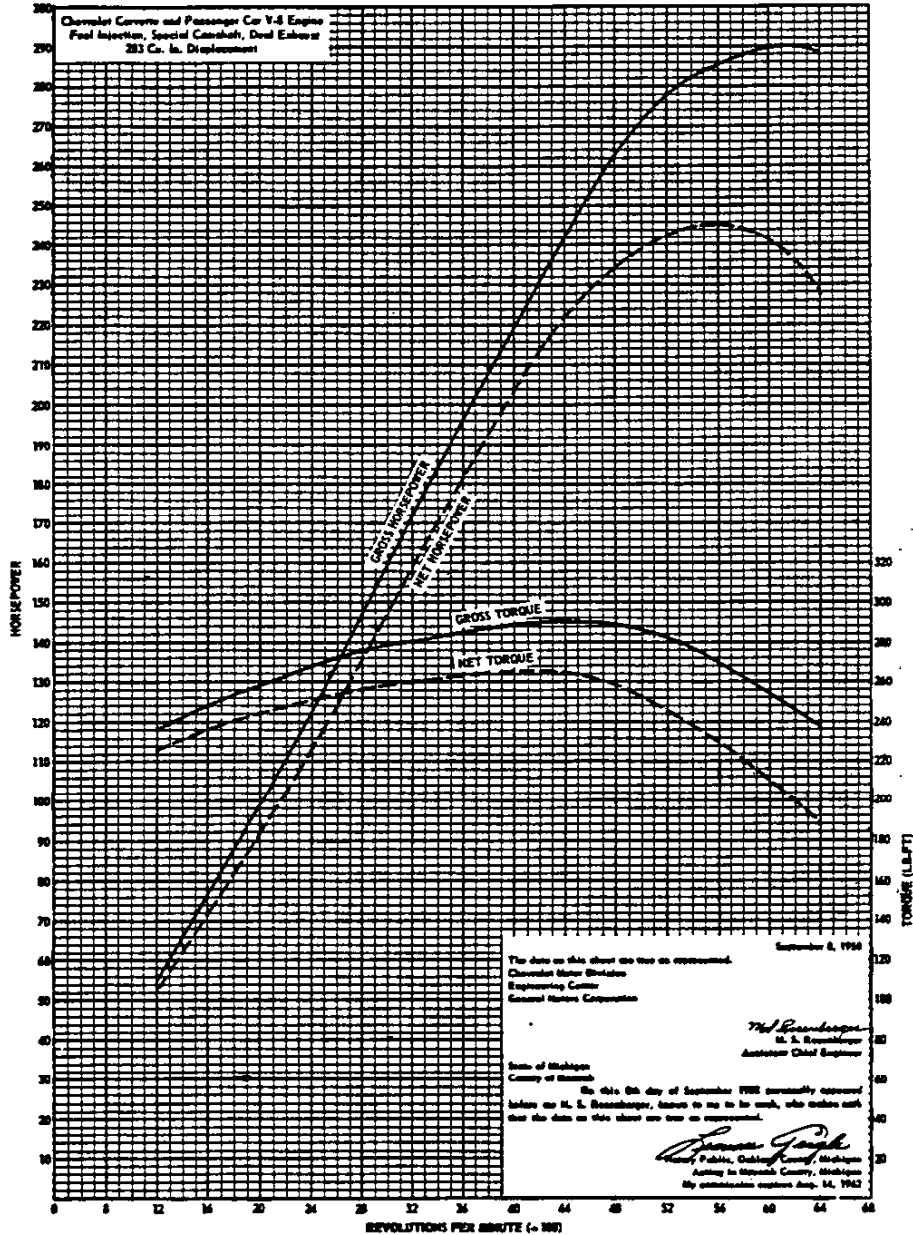

The engine performance curves shown on this sheet are taken from Chevrolet engine test report 17696-12. They represent the full throttle performance of a Chevrolet Corvette V-8 engine with 283 cubic inch displacement, as obtained from dynamometer test data corrected to standard barometric pressure of 29.92 inches of mercury and the standard temperature of 60°F.

GROSS POWER and TORQUE were obtained in a regular dynamometer test with the dynamometer exhaust system, no fan, generator not charging, and optimum spark advance.

NET POWER and TORQUE were obtained from a dynamometer test simulating actual operating conditions when the engine is in its vehicle. It includes the use of the regular mufflers and pipes, the fan in operation and automatic spark advance. The generator is not charging.

GROSS POWER and TORQUE were obtained in a regular dynamometer test with the dynamometer exhaust system, no fan, generator not charging, and optimum spark advance.

NET POWER and TORQUE were obtained from a dynamometer test simulating actual operating conditions when the engine is in its vehicle. It includes the use of the regular mufflers and pipes, the fan in operation and automatic spark advance. The generator is not charging.

ular dynamometer test with the dynamometer exhaust system, no fan, generator not charging, and optimum spark advance.

NET POWER and TORQUE were obtained from a dynamometer test simulating actual operating conditions when the engine is in its vehicle. It includes the use of the regular mufflers and pipes, the fan in operation and automatic spark advance. The generator is not charging.

283 CUBIC INCH V-8 ENGINE - Continued

ENGINE - 283 cu. in. V8	Turbo-Fire	Super Turbo-Fire	Ramjet Fuel Injection	Ramjet Fuel Injection Special
-------------------------	------------	------------------	-----------------------	-------------------------------

CYLINDER HEAD AND CASE

Material	Cast alloy iron
Bore Diameter	3.8745-3.8775
Head Bolt Torque	60-70 lb. ft.
No. of Cylinder Head Bolts	34

CRANKSHAFT

Material	Forged steel
End Play	.002-.006
Vibration Damper	Oscillating (rubber mounted)
Weight (pounds)	48
Counterweights	7
Crankshaft Pulley Diameter	6.64 P. D.

MAIN BEARINGS

Material	Steel backed babbitt	Premium*
Type	Precision, removable	
End Thrust Against Bearing	#5	
Dimensions		
Bearing #1 thru 4		
Theoretical I. D.	2.3004	
Effective length	.762	
Projected area	1.753 sq. in.	
Bearing #5		
Theoretical I. D.	2.3004	
Effective length	1.169	
Projected area	2.689 sq. in.	

CRANKSHAFT AND BEARINGS

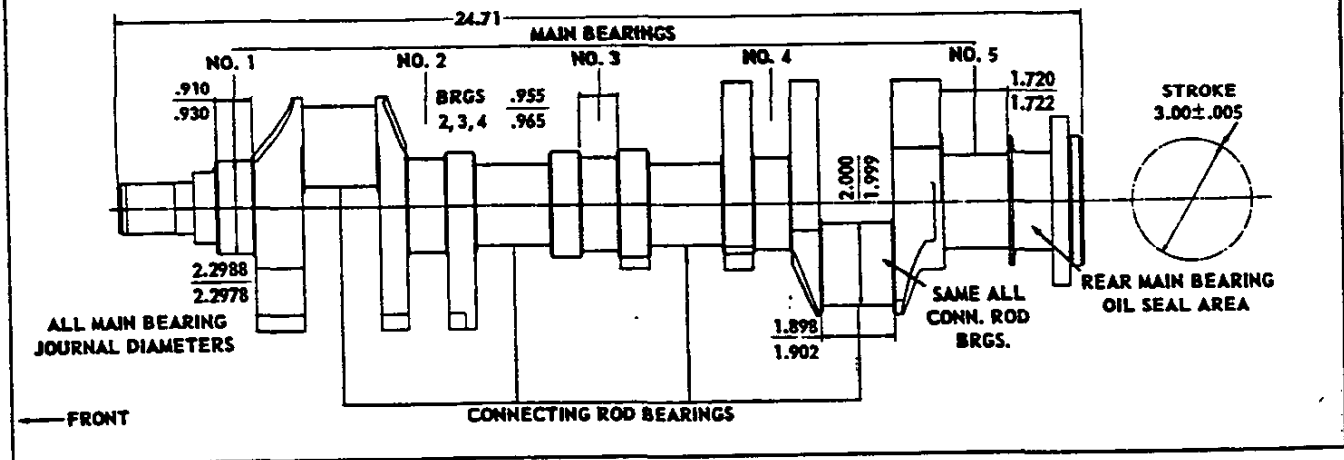

CAMSHAFT AND BEARINGS

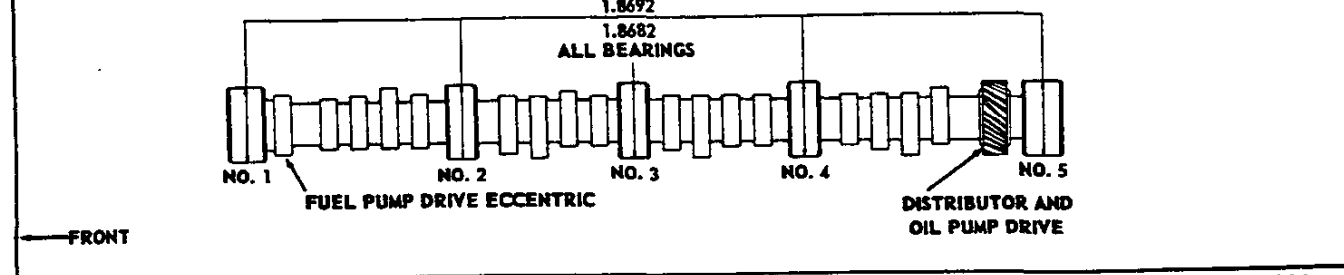

* - Steel backed aluminum alloy matrix with a thin lead alloy overplate except rear, which is steel backed babbitt.

ENGINE - 283 cu. in. V8	Turbo-Fire	Super Turbo-Fire	Ramjet Fuel Injection	Ramjet Fuel Injection Special
-------------------------	------------	------------------	-----------------------	-------------------------------

CAMSHAFT

Make	Own
Material	Cast alloy iron

CAMSHAFT BEARINGS

Material	Steel backed babbitt
Dimensions	
Bearing #1 thru 4	
Theoretical I. D.	1.8712
Effective length	.740
Projected area	1.385 sq. in.
Bearing #5	
Theoretical Length	1.8712
Effective length	.940
Projected Area	1.759 sq. in.

CAMSHAFT DRIVE

Type	Chain and sprocket
Sprocket Material	
Crankshaft (drive)	Steel
Camshaft (driven)	Cast alloy iron
Timing Chain	
Make	Link belt
No. of links	46
Width	.875
Pitch	.500

VALVE MECHANISM

Type	Rocker arm, push rod actuated	
Lifters	Hydraulic	Mechanical
Body material		
Foot	Cast alloy iron	
Sleeve	Steel	
Plunger	Steel	
Push rod	Steel	
Rocker Arm Ratio	1.5:1	
Valve Lash (hot)		
Inlet	Zero	.012
Exhaust	Zero	.018

VALVES

Inlet		
Material	High alloy steel (8645)	
Overall length	4.9024-4.9224	4.8699-4.8899
Stem to guide clearance	.0010-.0027	
Lift	.3987	.39375
Exhaust		
Material	High alloy steel (21-4N)	
Overall length	4.913-4.933	4.8905-4.9105
Stem to guide clearance	.0015-.0032	
Lift	.3987	.39975

VALVE SPRINGS

Material	High alloy steel (GM63M)
Compressed Length	
Valve closed	
Inlet and exhaust	1.696@ 69-79 lb.
Valve opened	
Inlet and exhaust	1.306@ 159-169 lb.
Free length	
Inlet and exhaust	2.08

283 CUBIC INCH V-8 ENGINE - Continued

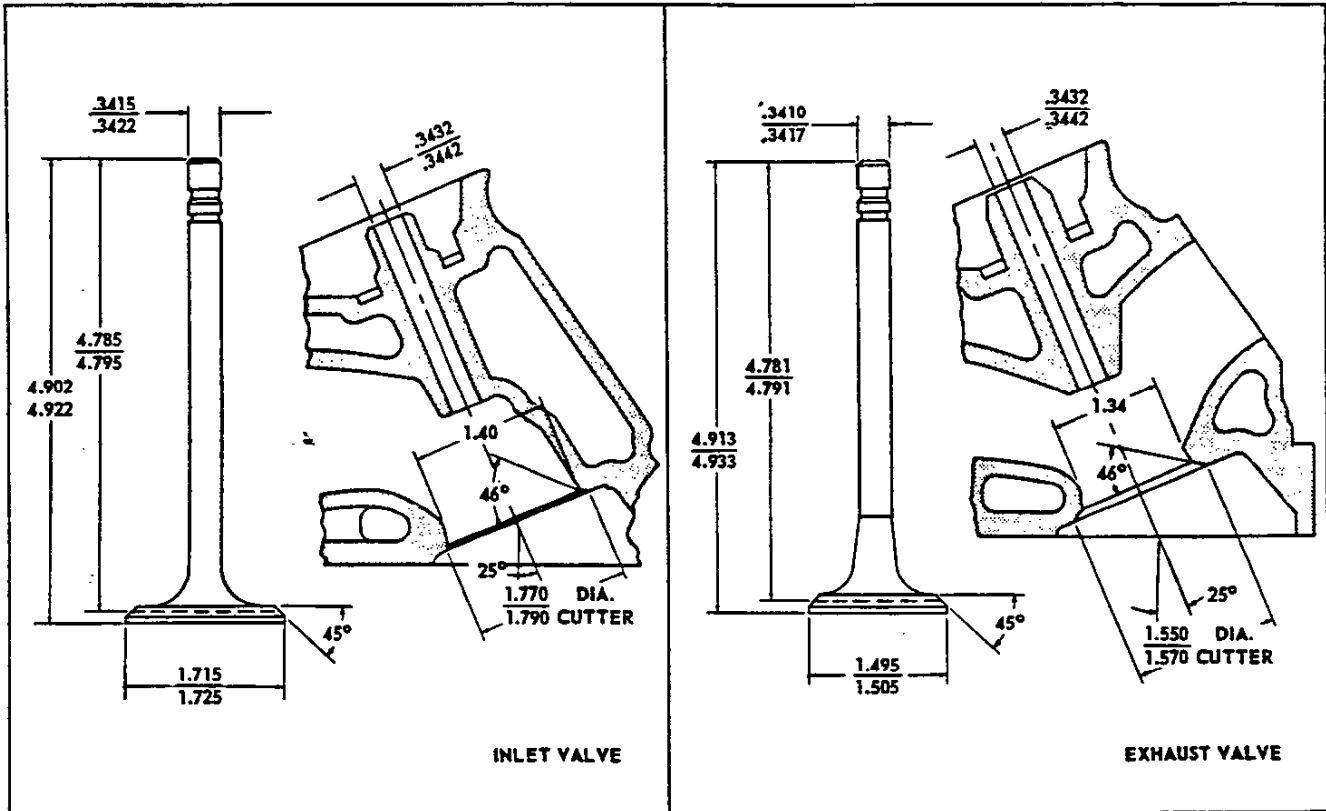

ENGINE-283 cu. in. V-8	Turbo-Fire	Super Turbo-Fire	Ramjet Fuel Injection	Ramjet Fuel Injection Special
------------------------	------------	------------------	-----------------------	-------------------------------

VALVE SPRING DAMPERS

No. of Coils		4
Free Length		2.00

PISTONS

Material	Cast aluminum alloy	
Type		
Head	Flat, notched	Dome, notched
Skirt	Slipper	
Weight (ounces)	20.96	25.60
Top Land Clearance	.035-.043	
Skirt Clearance	.0006-.0010	.0016-.0020
Groove Depth		
Compression ring	.2153-.2218	
Oil ring	.2093-.2158	

PISTON PINS

Material	Chromium steel
Type	Rod shrunk fit to pin
Length	2.990-3.010
Diameter	.9270-.9273
Clearance in Piston	.00015-.00025
Direction of Offset	Major thrust side

COMPRESSION RINGS

No. per Piston	Two
Type	
Upper and lower	Thickwall, inside bevel or counter bore

10-15-58 • Revised 3-23-59

18-ENGINES AND CLUTCHES

1959 CHEVROLET CHEVROLET PASSENGER CAR

ENGINE - 283 cu. in. V-8	Turbo-Fire	Super Turbo-Fire	Ramjet Fuel Injection	Ramjet Fuel-Injection Special
--------------------------	------------	------------------	-----------------------	-------------------------------

COMPRESSION RINGS - Continued

Material	Cast alloy iron		
Coating			
Upper	Flash chrome plating	.004-.007 chrome plating	
Lower	Wear resistant		
Width	.0775-.0780	.0770-.0780	
Gap	.010-.020		
Wall Thickness	.184-.194		

OIL CONTROL RINGS

No. per Piston	One		
Type	Multi-piece (2 steel rails and one spacer)		
Material - Spacer	Steel	Cast alloy iron	
Coating			
Upper and lower rails	Chrome plated O. D.		
Width	.224-.231	.1860-.1865	
Gap	.015-.055		
Wall Thickness	.150-.156	.152-.158	

CONNECTING RODS

Material	Drop forged steel		
Length (center to center)	5.699-5.701		
Bearings			
Material	Steel backed babbitt	Premium*	
Type	Precision, removable		
Effective length	.817		
Clearance	.0007-.0027		
End play	.008-.014		
Theoretical I. D.	2.0012		
Projected area	1.635 Sq. In.		

TIMING DIAGRAM DATA

Inlet Valve			
Opens - BTC	12°30'	35°	
Closes - ABC	57°30'	72°	
Exhaust Valve			
Opens - BBC	54°30'	76°	
Closes - ATC	15°30'	31°	
Ramp			
Inlet			
Opening	.0047, 10°	.0067, 18°	
Closing	.0067, 15°		
Exhaust			
Opening	.0047, 10°	.0107, 29°	
Closing	.0067, 15°		
Tappet Lift			
Inlet	.26581		.2625
Exhaust			.2665

INLET MANIFOLD

Material	Cast alloy iron	Cast aluminum
----------	-----------------	---------------

* - Steel backed aluminum alloy matrix with a thin lead alloy overplate

283 CUBIC INCH V-8 ENGINE - Continued
LUBRICATION SYSTEM

ENGINE - 283 cu. in. V-8	Turbo-Fire	Super Turbo-Fire	Ramjet Fuel Injection	Ramjet Fuel Injection Special
---------------------------------	-------------------	-------------------------	------------------------------	--------------------------------------

METHOD OF LUBRICATION

Type	Controlled full pressure
Main Bearings	Pressure
Connecting Rods	Pressure
Piston Pins	Splash
Cylinder Walls	Pressure, jet cross sprayed
Camshaft Bearings	Pressure
Valve Lifters	Pressure
Timing Gears	Nozzle sprayed

OIL PUMP

Type	Gear
Normal Oil Pressure	35 psi @ 2000 RPM
Intake Type	Fixed
Capacity (GPM @ RPM, hot)	4.0-4.2 @ 1170-1200

CRANKCASE CAPACITY (quarts)

Dry	4.5
Refill	4.0

OIL PRESSURE SENDING UNIT

Type	Electrical
------	------------

OIL FILTER

Availability	RPO 237	Production
Type	Full flow, spring loaded disc by-pass	
Capacity (dry)	1.0 qt.	
Replacement Type	Element	

LUBRICANT GRADES AND TEMPERATURES

32°F and Above	SAE 20W, SAE 20, or SAE 10W-30
0°F and Above	SAE 10W or SAE 10W-30
Below 0°F	SAE 5W or SAE 5W-20

CRANKCASE VENTILATION

Type	Road draft
------	------------

FUEL AND EXHAUST SYSTEM

FUEL PUMP

Make	AC
Type	Mechanical
Pressure Range	5.25-6.50 psi

MANIFOLD HEAT CONTROL

Type	Automatic
------	-----------

AIR CLEANER

Make	AC	
Type	Dry	
Element	Paper	
Location	On carburetor air horn	On radiator bulkhead
Air Intake Duct		Channel air from air cleaner to air meter adapter

FUEL TANK

Capacity (gallons)	
Station Wagons and Sedan Delivery	17*
Others	20

*- 9-pass. Station Wagon has 18 gal. capacity.

ENGINE-283 cu. in. V8	Turbo-Fire	Super Turbo-Fire	Ramjet Fuel Injection	Ramjet Fuel Injection Special
-----------------------	------------	------------------	-----------------------	-------------------------------

FUEL TANK-Continued

Filler Location	
Station Wagon and Sedan Delivery	In left rear quarter panel
Others	Center of body back lower panel at rear of hinged license plate

CARBURETORS

Conventional Transmission			
Make	Rochester	Carter	
Model	7013007	3756676	
Automatic Transmission			
Make	Rochester		
Model	7013008	7013004	
Type	2 bbl., downdraft	4 bbl., downdraft	
SAE Flange Size	1.25		
Venturi ID by Make*	Rochester	Carter	
Primary	1.09	1.00	1.00
Secondary		1.06	1.13
Throttle Bore	1.4375	1.3125	
Choke	Automatic		

FUEL INJECTION SYSTEM

Make	Rochester Products	
Type	Constant flow	
Model	7017200	7017250

AIR INDUCTION

Air Meter	
Location	Left side of engine
Plenum Chamber	
Location	Integral with inlet manifold
Ram Pipes	
Number	Eight
Location	Integral with inlet manifold
Length	12"

AIR/FUEL RATIO CONTROL

Type	Vacuum sensitive diaphragm
Location	On fuel meter assembly

FUEL METER PUMP

Type	Gear
Drive	Gear driven by flexible shaft from distributor
Pressure (maximum)	300 psi

INJECTION NOZZLES

Number	Eight
Material	Brass
Location	On inlet manifold above intake ports
Fuel Orifice Size	0118
Insulation	Bakelite block

AUTOMATIC ENRICHMENT

Type	Electric, time-temperature
Location	On air meter assembly
Current Draw	1 amp. @ 70°F

INLET MANIFOLD ADAPTER

Material	Cast aluminum
----------	---------------

* - Primary and Secondary applies to 4-bbl carburetors only
1959 CHEVROLET PASSENGER CAR

• Revised 3-23-59 10-15-58
ENGINES AND CLUTCHES-21

283 CUBIC INCH V-8 ENGINE - Continued

ENGINE - 283 cu. in. V-8	Turbo-Fire	Super Turbo-Fire	Ramjet Fuel Injection	Ramjet Fuel Injection Special
---------------------------------	-------------------	-------------------------	------------------------------	--------------------------------------

FUEL FILTER

In Fuel Tank	Screen		
In Carburetor Inlet	Sintered bronze filter		
Make			AC
Model			GF43
Element			Paper
Location			On engine top cover

FUEL GAUGE

Make	AC
Type	Electric

EXHAUST SYSTEM

Type		
Production	Single	Dual with resonators
RPO 220	Dual with resonators	
Flow		Reverse
Exhaust Pipe		
Outer diameter		2.00
Wall thickness		.0625
Tail Pipe		
Inner diameter		1.81
Wall thickness		.0598

COOLING SYSTEM

GENERAL

Type	Pressure, full length water jacket around each cylinder
Shroud	Regular production

THERMOSTAT

Make	Harrison
Type	Pellet
Begins to Open @	167-172°F
Fully Open @	192°F

RADIATOR

Make	Harrison
Type	Tube on center
Core Constant and Thickness	
Regular	.30 x .55 x 1.75
Powerglide	.25 x .55 x 1.75
Turboglide	.22 x .55 x 1.75
Frontal Area	390 sq. in.
Capacity (quarts)	
Regular transmission	
Less heater	17.5
With heater	18.5
Automatic transmission	
Less heater	17.25
With heater	18.25

RADIATOR HOSE

Location		
Inlet	Thermostat housing to radiator	
Outlet	Water pump to radiator	
Type		
Inlet	Molded elbow	Compound curve
Outlet	Molded elbow	
Inside Diameter		
Inlet	1.50	
Outlet	1.75	

ENGINE - 283 cu. in. V-8	Turbo-Fire	Super Turbo-Fire	Ramjet Fuel Injection	Ramjet Fuel Injection Special
--------------------------	------------	------------------	-----------------------	-------------------------------

RADIATOR CAP

Type	Pressure
Valve Opens @	13 psi

FAN

Number of Blades	4 staggered
Diameter	17.62
Ratio (fan to engine RPM)	.949:1

FAN AND GENERATOR BELT

Number Used	One
Angle of "V"	37-44°
Pitch Line Length	54.12
Width	.380±.005
Fan Pulley Size	7.00 P. D., 36° V

WATER PUMP

Type	Centrifugal
Capacity (GPM @ RPM)	44.5 @ 4000
Drive	Fan belt
Bearing	Permanently lubricated double row ball

ELECTRICAL SYSTEM

GENERATOR

Make	Delco-Remy
Model	1102097
Type	Two brush, shunt wound
Drive	By fan belt
Pulley Size	2.88 P. D.
Generator RPM/MPH	Approx. 107
Maximum Output (hot)	
@ Generator RPM	2450
@ Engine RPM	1065
Ratio (gen. to engine RPM)	2.3:1
Rating	
Amperes	30
Volts	12-15

OPTIONAL GENERATOR EQUIPMENT

Model	
35 amp (RPO 338)	1102114
40 amp (RPO 326)	1105123 (Medium duty)
50 amp (RPO 378)	1106985 (Low cut-in)

BATTERY

Make	Delco-Remy
Model	1980458
Voltage Rating	12
Number of Cells	6
Plates per Cell	9
Terminal Grounded	Negative
Location	Right front of engine compartment on radiator baffle
Capacity	53 amp. hr. @ 20 hr. rate

OPTIONAL BATTERY EQUIPMENT (RPO 345)

Model	1980668
Number of Cells	6
Plates per Cell	11
Capacity	70 amp. hr. @ 20 hr. rate

283 CUBIC INCH V-8 ENGINE - Continued

ENGINE - 283 cu. in. V8	Turbo-Fire	Super Turbo-Fire	Ramjet Fuel Injection	Ramjet Fuel Injection Special
-------------------------	------------	------------------	-----------------------	-------------------------------

VOLTAGE AND CURRENT REGULATOR

Make	Delco-Remy
Model	1119001
Type	Vibrator
Cut-Out Relay	
Closing voltage @ generator RPM	11.8-13.5 @ 1300
Voltage Regulator	
Voltage	13.8-14.8
Current Regulator	
Amperes	27-33

STARTING MOTOR

Make	Delco-Remy
Model	
Conventional & Powerglide	1107664
Turboglide	1107694
Rotation (drive end view)	Clockwise
Test Conditions	Engine @ operating temperature
No Load Test	
Amps	49-76
Volts	10.6
RPM	6200-9400
Drive	
Engagement type	Positive shift solenoid
Number of teeth	9
Gear ratio	
Flywheel to starter	18.6:1
Flywheel face tooth width	
Turboglide	.3435
Regular & Powerglide	.4135

STARTING

Ignition Switch	
Positions	Locked Off, Unlocked Off, On, Start
Starting Procedure	
Regular transmission	Turn ignition key to extreme right after placing shift lever in neutral and depressing clutch
Automatic transmission	Turn key to extreme right, selector in Park or Neutral

COIL

Make	Delco-Remy
Model	1115115
Amperes	1115083
Engine stopped	4.0
Engine idling	1.8

IGNITION TIMING

Crankshaft Degrees	
Initial setting	4° BTC
Mark Location	Vibration damper
Firing Order	1-8-4-3-6-5-7-2

SPARK PLUG

Make	AC
Model	44
Thread Size	14 mm
Gap	.033-.038
Torque (lb. ft.)	25

ENGINE - 283 cu. in. V8	Turbo-Fire	Super Turbo-Fire	Ramjet Fuel Injection	Ramjet Fuel Injection Special
-------------------------	------------	------------------	-----------------------	-------------------------------

DISTRIBUTOR

Make	Delco-Remy			
Model	1110947	1110946	1110915	1110914*
Breaker Gap	.016-.021			
Cam Angle	26°-33°			
Breaker Arm Tension	19-23 oz.			
Spark Advance Data				
Centrifugal advance				
Begins (RPM)	600		1000	
Maximum degrees @ RPM	28 @ 3750	28 @ 3700		22 @ 6000
Vacuum advance				
Maximum degrees @ "Hg	15 @ 15.5		24 @ 13.5	

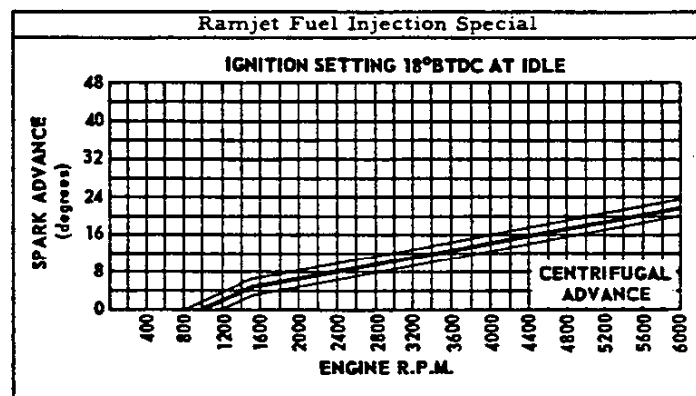
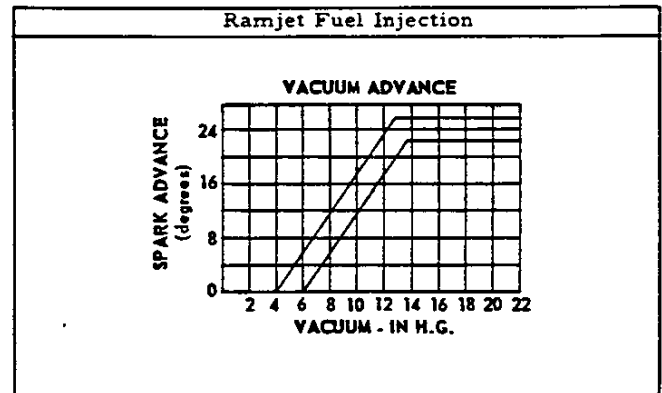
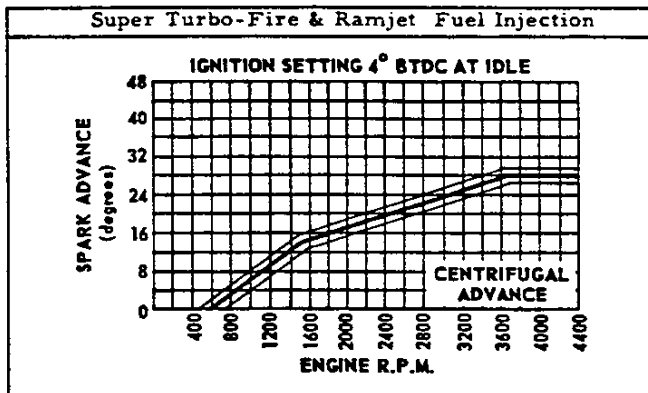
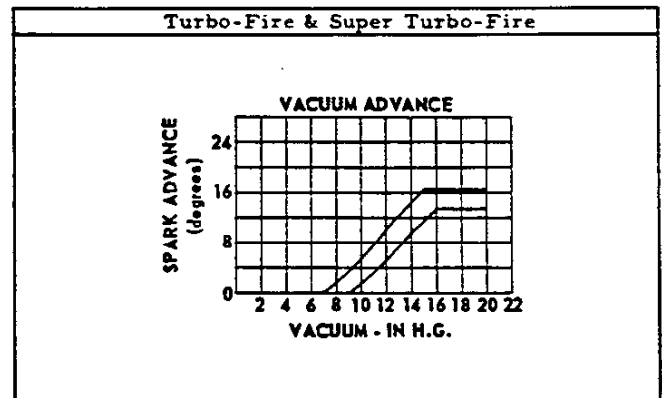
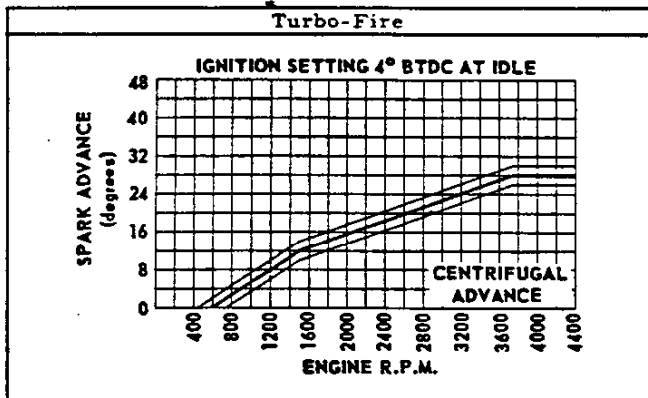

* - Dual breaker points
1959 CHEVROLET PASSENGER CAR

● Revised 3-23-59 10-15-58
ENGINES AND CLUTCHES - 25

348 CUBIC INCH V-8 ENGINE

GENERAL DATA

Engine		Conventional	Powerglide	Turboglide
Piston displacement (cu. in.)		348		
Type		Valve-in-head		
Number of cylinders		8		
Bore and stroke (nominal)		4.125 x 3.25		
Compression ratio		9.5:1**		
Taxable (SAE) horsepower		54.5		
Idling speed (RPM)		475 in neutral	450 in drive	
Compression press. (PSI) @ cranking speed, engine hot		150		
Dry weight (pounds)	Engine and clutch	715	650	640
	With transmission	775	875	790
Lubrication		Full pressure		
Power plant mounting		Three point mounting, two front and one rear combination compression and shear type		
Measurements (inches)	Fan to rear of flywheel housing	38.23	33.82	
	Front cylinder block to rear of flywheel housing	29.92	25.51	
	Length of cylinder block	23.63		
	Exhaust manifold to ϕ generator (width)	25.57		
	Top air cleaner to bottom oil pan	28.90		

ADVERTISED MAXIMUM ENGINE PERFORMANCE

Engine		Turbo-Thrust	Turbo-Thrust Special		Super Turbo-Thrust	Super Turbo-Thrust Special
Carburetor		(RPO 576)		(RPO 577)	(RPO 573)	(RPO 574)
Camshaft		4-barrel		3x2-barrel		
		Standard	Special		Standard	Special
Brake	Gross	250 @ 4400 rpm	305 @ 5600 rpm +	320 @ 5600 rpm	280 @ 4800 rpm	335 @ 5800 rpm
Horsepower	Net	210 @ 4400 rpm	NA	NA	235 @ 4800 rpm	NA
Torque (lb.-ft)	Gross	355 @ 2800 rpm	350 @ 3600 rpm +	358 @ 3600 rpm	355 @ 3200 rpm	362 @ 3600 rpm
	Net	320 @ 2600 rpm	NA	NA	320 @ 2800 rpm	NA

ENGINE SPEED AND PISTON TRAVEL

Transmission		3-Speed (Production)		4-Speed (RPO 685)	Powerglide (RPO 313)*	Turboglide (RPO 302)*
Rear axle ratio		3.36:1		3.55:1		3.08:1
Tire size		7.50 x 14-4\$				
Crankshaft rpm		2651.0		2801.0		2430.1
Crankshaft rpm @ 1 mph	Low	109.2	115.3	102.7	85.0+	73.7
	Reverse	123.8	130.8	105.5		
	Second	67.6	71.5	77.5		
	Third			61.2		
	Direct ϕ	44.2		46.7		40.5
Piston travel (ft/mile)		1434.2		1515.3		1314.7

* - Data computed assuming zero slippage in torque converter.

+ - Heavy Duty Powerglide

** - 11.0:1 with 4-barrel carburetor, special camshaft, and HD Powerglide; 11.25:1 with special camshaft and synchromesh transmissions.

\$ - 8.00 x 14-4 tires standard equipment on 1867, station wagon, Sedan Delivery and Sedan Pick-up.

ϕ - Also known as N/V factor.

10-15-58 • Revised 3-23-59

26-ENGINES AND CLUTCHES

1959 CHEVROLET PASSENGER CAR

ADVERTISED CAR PERFORMANCE

3 Speed Transmission	ENGINE			
	Turbo-Thrust	Turbo-Thrust Special	Super Turbo-Thrust	Super Turbo-Thrust Special
Model	1619			
Performance weight (pounds) +	4520	4525	4530	4535
Pounds per gross horsepower	18.08	14.14	16.18	13.54
Pounds, per cu. in. displacement	12.99	13.00	13.02	13.03
Gross horsepower per cu. in. displacement	.718	.920	.805	.963
Power displacement (cu. ft./mile) @	265.2	280.2	265.2	280.2
Displacement factor (cu. ft./ton mile) #	117.3	123.9	117.1	123.6
4-Speed Transmission				
Performance weight (pounds) +	4535	4545	4545	4550
Pounds per gross horsepower	18.14	14.20	16.23	13.58
Pounds per cu. in. displacement	13.03	13.06	13.06	13.07
Gross horsepower per cu. in. displacement	.718	.920	.805	.963
Power displacement (cu. ft./mile) @	265.2	280.2	265.2	280.2
Displacement factor (cu. ft./ton mile) #	117.0	123.3	116.7	123.2
Powerglide Transmission *				
Performance weight (pounds) +	4620	4630	4635	
Pounds per gross horsepower	18.48	15.18	16.55	
Pounds per cu. in. displacement	13.28	13.30	13.32	
Gross horsepower per cu. in. displacement	.718	.876	.805	
Power displacement (cu. ft./mile) @	243.2	280.2	243.2	
Displacement factor (cu. ft./ton mile) #	105.3	121.1	104.9	
Turboglide Transmission *				
Performance weight (pounds) +	4545		4555 ✓	
Pounds per gross horsepower	18.18		16.27	
Pounds per cu. in. displacement	13.06		13.09	
Gross horsepower per cu. in. displacement	.718		.805	
Power displacement (cu. ft./mile) @	243.2		243.2	
Displacement factor (cu. ft./ton mile) #	107.0		106.8	

- + - Curb weight plus 600 lb. (weight of 4 150# passengers).
- * - Data computed assuming zero slippage in torque converter.
- @ - $\frac{\text{Crankshaft revolutions per mile} \times \text{piston displacement} + 2}{1728}$
- # - Power displacement divided by performance weight in tons.

348 CUBIC INCH V-8 ENGINE - Continued
 TURBO-THRUST 348 CUBIC INCH V-8 ENGINE

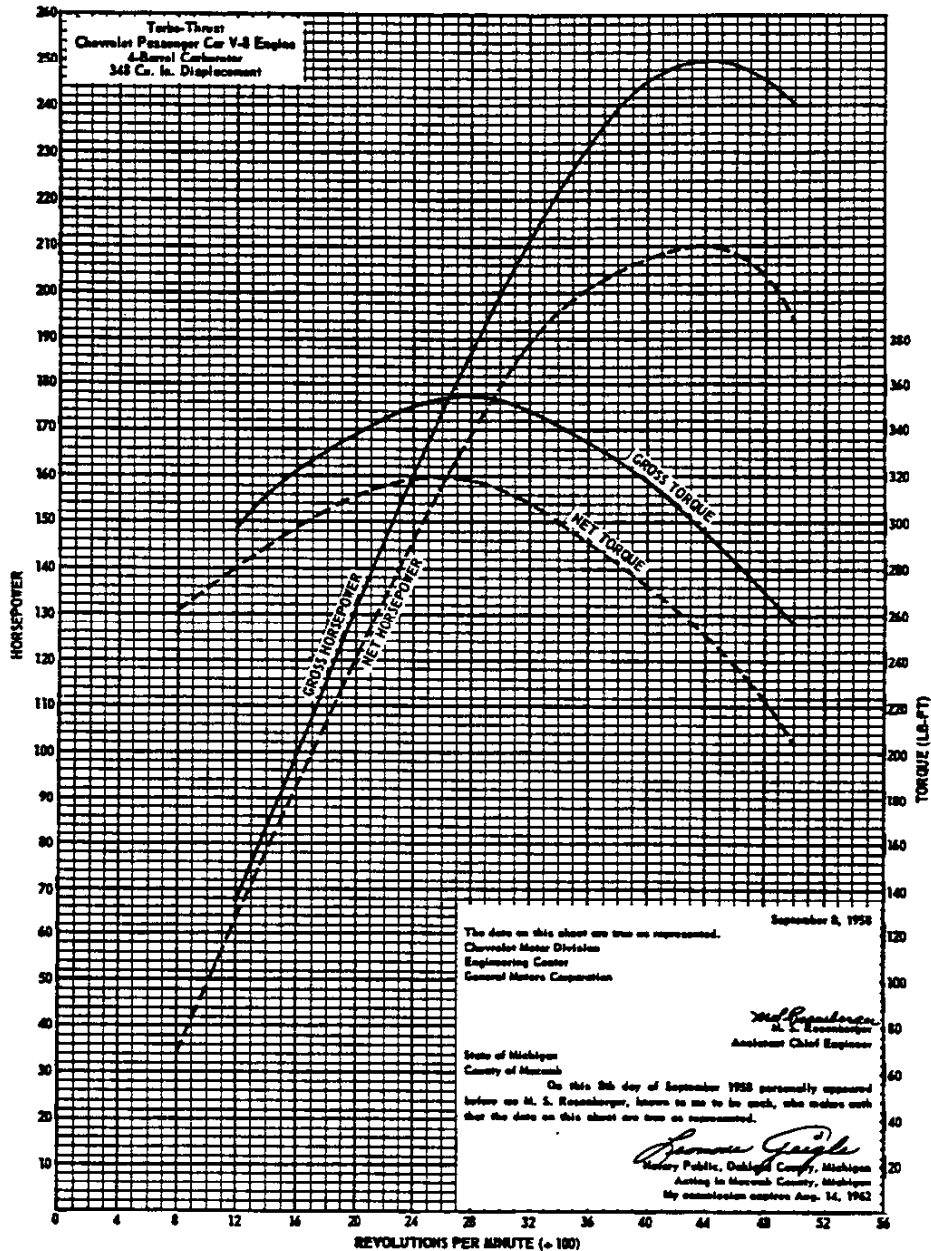

The engine performance curves shown on this sheet are taken from Chevrolet engine test report 17688-144. They represent the full throttle performance of a Turbo-Thrust 348 Chevrolet passenger car engine with 348 cubic inch displacement, as obtained from dynamometer test data corrected to standard barometric pressure 29.92 inches of mercury and the standard temperature of 60°F.

ular dynamometer test with the dynamometer exhaust system, no fan, generator not charging, and optimum spark advance.

NET POWER and TORQUE were obtained from a dynamometer test simulating actual operating conditions when the engine is in its vehicle. It includes the use of the regular mufflers and pipes, the fan in operation and automatic spark advance. The generator is not charging.

GROSS POWER and TORQUE were obtained in a reg-
 10-15-58
 28-ENGINES AND CLUTCHES

TURBO-THRUST SPECIAL 348 CUBIC INCH V-8 ENGINE
 (With Special Camshaft and Synchromesh Transmission)

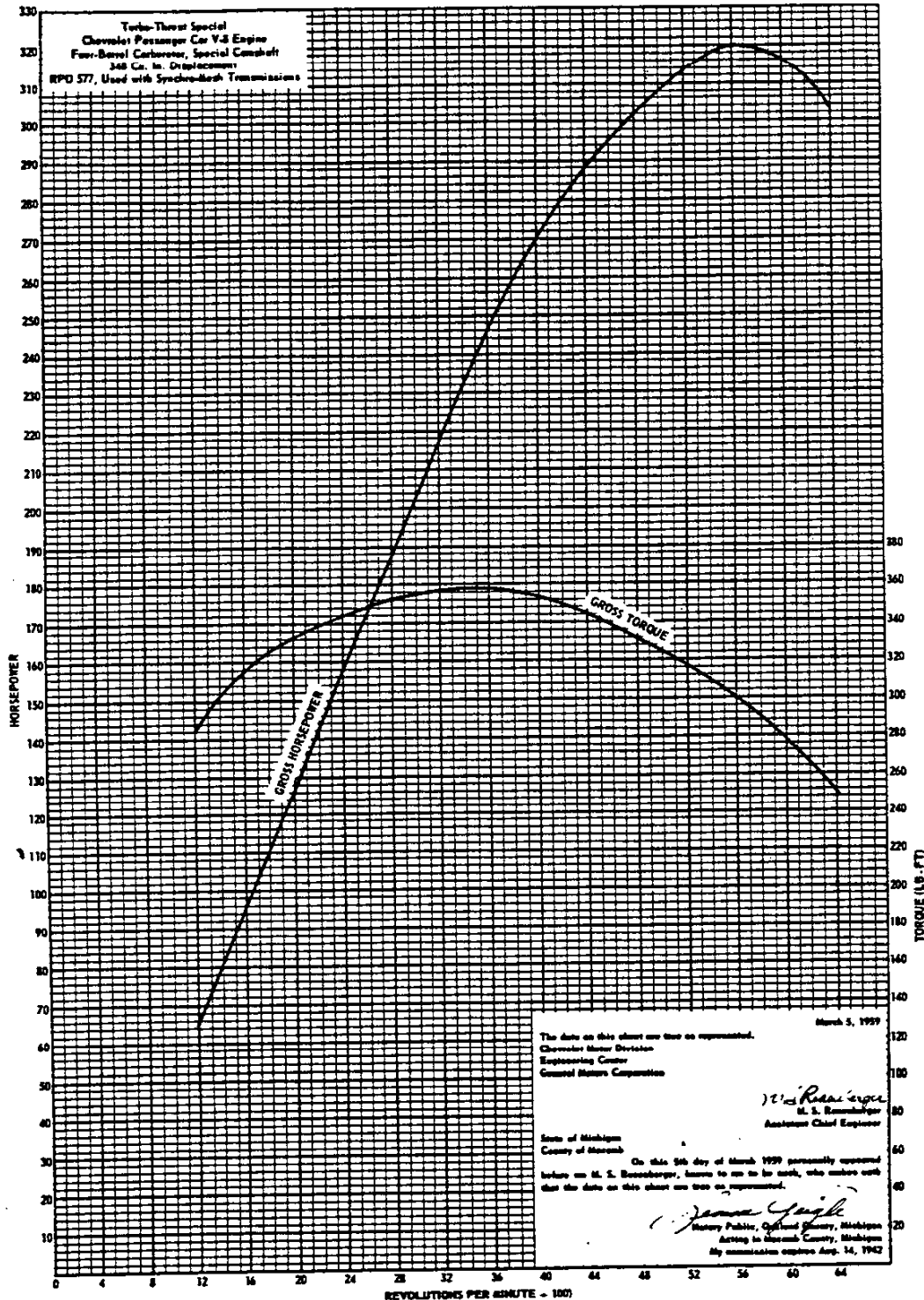

The engine performance curves shown on this sheet are taken from Chevrolet engine test report 18005-41. They represent the full throttle performance of a Turbo-Thrust Special Chevrolet passenger car engine with 348 cubic inch displacement, as obtained from dynamometer test data corrected to standard barometric pressure 29.92 inches of mercury and the

standard temperature of 60°F.

GROSS POWER and TORQUE were obtained in a regular dynamometer test with the dynamometer exhaust system, no fan, generator not charging, and optimum spark advance.



.

,

1

2

3

4

5

6

TURBO-THRUST SPECIAL 348 CUBIC INCH V-8 ENGINE
(With Special Camshaft and Heavy Duty Powerglide Transmission)

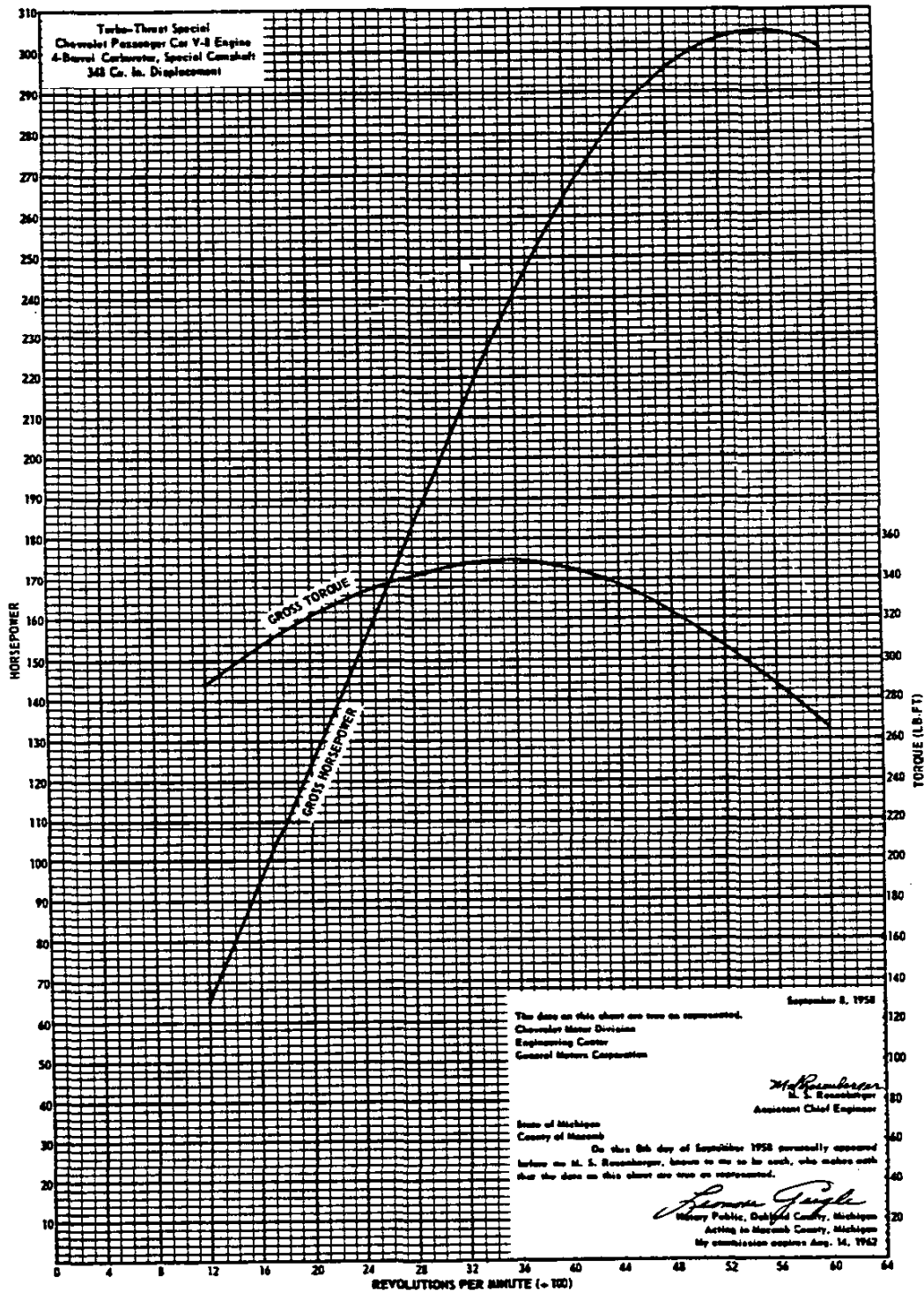

The engine performance curves shown on this sheet are taken from Chevrolet engine test report 18005-8. They represent the full throttle performance of a Turbo-Thrust Special Chevrolet passenger car engine with 348 cubic inch displacement, as obtained from dynamometer test data corrected to standard barometric pressure 29.92 inches of mercury and the

standard temperature of 60°F.

GROSS POWER and TORQUE were obtained in a regular dynamometer test with the dynamometer exhaust system, no fan, generator not charging, and optimum spark advance.

1959 CHEVROLET PASSENGER CAR

• Revised 3-23-59 10-15-58
ENGINES AND CLUTCHES-29

348 CUBIC INCH V-8 ENGINE - Continued

SUPER TURBO-THRUST
348 CUBIC INCH V-8 ENGINE

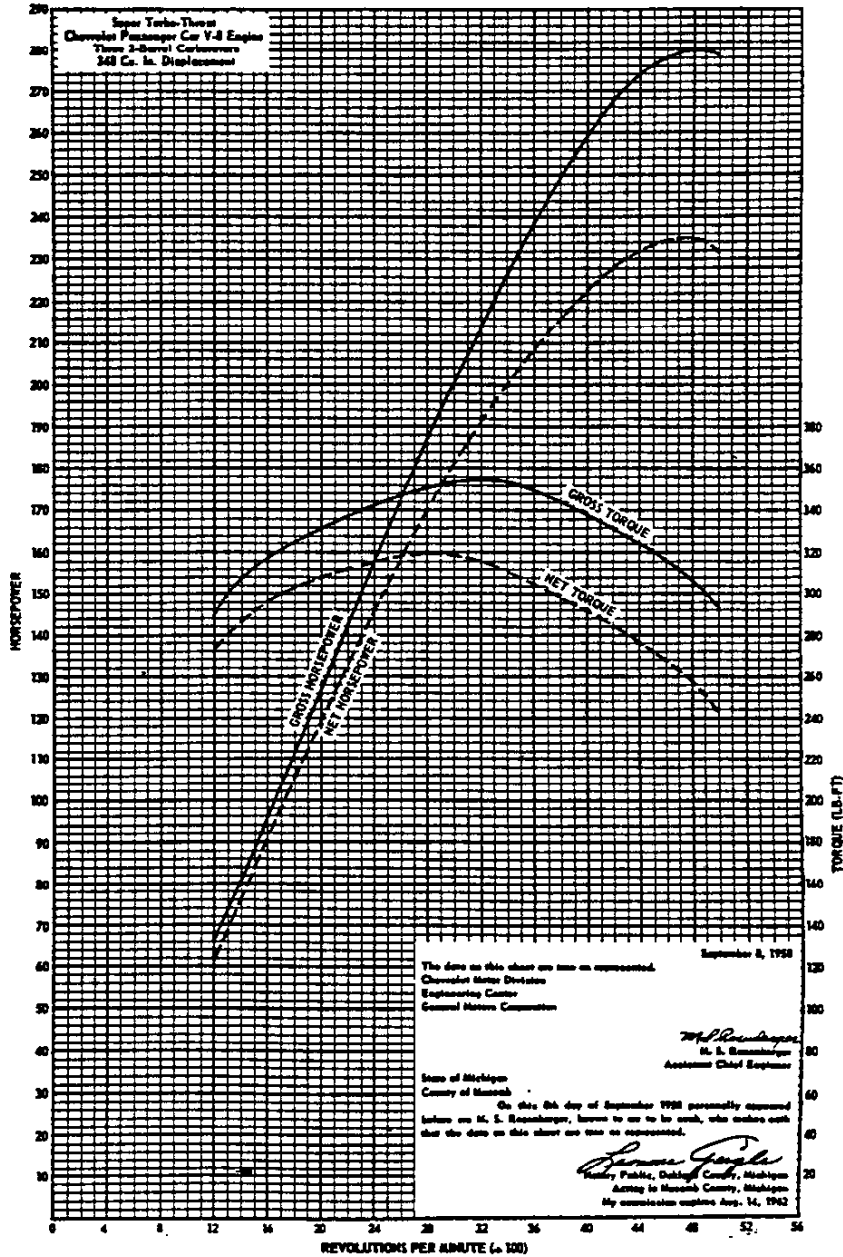

The engine performance curves shown on this sheet are taken from Chevrolet engine test report 17688-144. They represent the full throttle performance of a Super Turbo-Thrust Chevrolet passenger car engine with 348 cubic inch displacement, as obtained from dynamometer test data corrected to standard barometric pressure 29.92 inches of mercury and the standard temperature of 60°F.

GROSS POWER and TORQUE were obtained in a regular dynamometer test with the dynamometer exhaust system, no fan, generator not charging, and optimum spark advance.

GROSS POWER and TORQUE were obtained in a regular dynamometer test with the dynamometer exhaust system, no fan, generator not charging, and optimum spark advance.

NET POWER and TORQUE were obtained from a dynamometer test simulating actual operating conditions when the engine is in its vehicle. It includes the use of the regular mufflers and pipes, the fan in operation and automatic spark advance. The generator is not charging.

GROSS POWER and TORQUE were obtained in a regular dynamometer test with the dynamometer exhaust system, no fan, generator not charging, and optimum spark advance.

NET POWER and TORQUE were obtained from a dynamometer test simulating actual operating conditions when the engine is in its vehicle. It includes the use of the regular mufflers and pipes, the fan in operation and automatic spark advance. The generator is not charging.

GROSS POWER and TORQUE were obtained in a regular dynamometer test with the dynamometer exhaust system, no fan, generator not charging, and optimum spark advance.

NET POWER and TORQUE were obtained from a dynamometer test simulating actual operating conditions when the engine is in its vehicle. It includes the use of the regular mufflers and pipes, the fan in operation and automatic spark advance. The generator is not charging.

GROSS POWER and TORQUE were obtained in a regular dynamometer test with the dynamometer exhaust system, no fan, generator not charging, and optimum spark advance.

NET POWER and TORQUE were obtained from a dynamometer test simulating actual operating conditions when the engine is in its vehicle. It includes the use of the regular mufflers and pipes, the fan in operation and automatic spark advance. The generator is not charging.

GROSS POWER and TORQUE were obtained in a regular dynamometer test with the dynamometer exhaust system, no fan, generator not charging, and optimum spark advance.

NET POWER and TORQUE were obtained from a dynamometer test simulating actual operating conditions when the engine is in its vehicle. It includes the use of the regular mufflers and pipes, the fan in operation and automatic spark advance. The generator is not charging.

ular dynamometer test with the dynamometer exhaust system, no fan, generator not charging, and optimum spark advance.

NET POWER and TORQUE were obtained from a dynamometer test simulating actual operating conditions when the engine is in its vehicle. It includes the use of the regular mufflers and pipes, the fan in operation and automatic spark advance. The generator is not charging.

SUPER TURBO-THRUST SPECIAL 348 CUBIC INCH V-8 ENGINE
 (With Special Camshaft and Synchronesh Transmission)

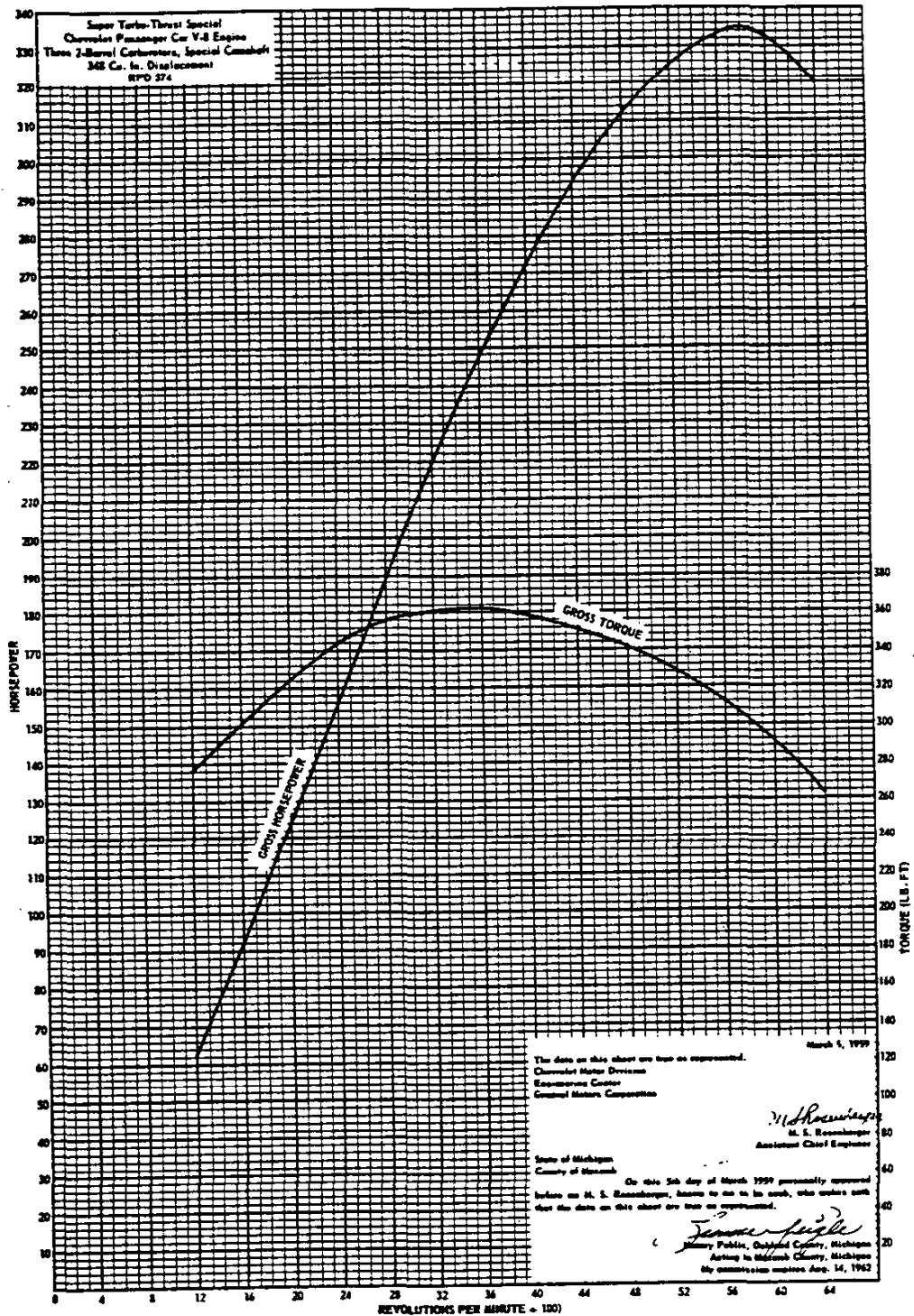

The engine performance curves shown on this sheet are taken from Chevrolet engine test report 18005-41. They represent the full throttle performance of a Super Turbo-Thrust Special Chevrolet passenger car engine with 348 cubic inch displacement, as obtained from dynamometer test data corrected to standard barometric pressure 29.92 inches of mercury and the

standard temperature of 60°F.

GROSS POWER and TORQUE were obtained in a regular dynamometer test with the dynamometer exhaust system, no fan, generator not charging, and optimum spark advance.

348 CUBIC INCH V-8 ENGINE - Continued

ENGINE - 348 cu in V-8	Turbo-Thrust	Super Turbo-Thrust	Turbo-Thrust Special	Super Turbo-Thrust Special
			HD PG	Synchromesh

CYLINDER CASE AND HEADS

Material	Cast alloy iron
Bore Diameter	4.124-4.127
Head Bolt Torque	60-70 lb. ft.
No. Cylinder Head Bolts	36

CRANKSHAFT

Material	Forged steel
End Play	.003-.007
Vibration Damper	Oscillating (rubber mounted)
Weight	58.75 lb.
Counterweights	6
Crankshaft Pulley Diameter	6.64 P. D.

MAIN BEARINGS

Material	Steel backed babbitt	Premium*
Type	Precision, removable	
End Thrust Against Bearing	#5	
Dimensions		
Bearing #1 thru 4		
Theoretical I. D.	2.5006	
Effective length	1.002	
Projected area	2.5056 sq. in.	
Bearing #5		
Theoretical I. D.	2.5006	
Effective length	1.262	
Projected area	3.1558 sq. in.	

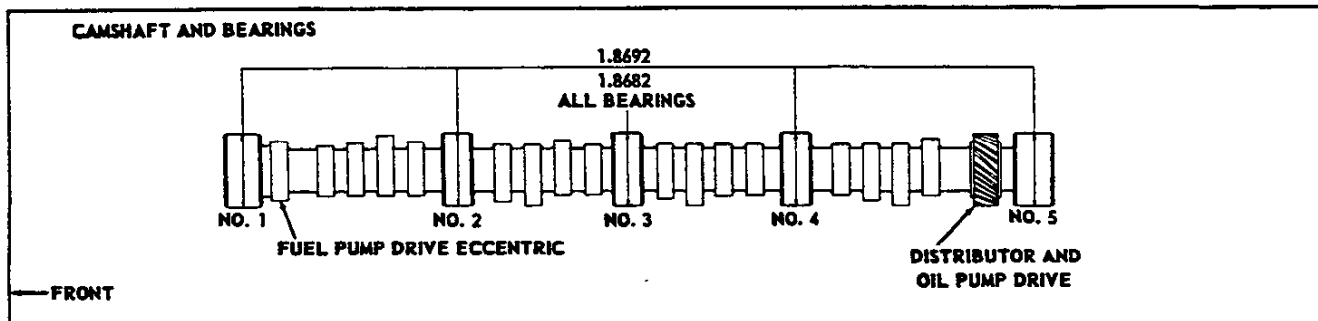
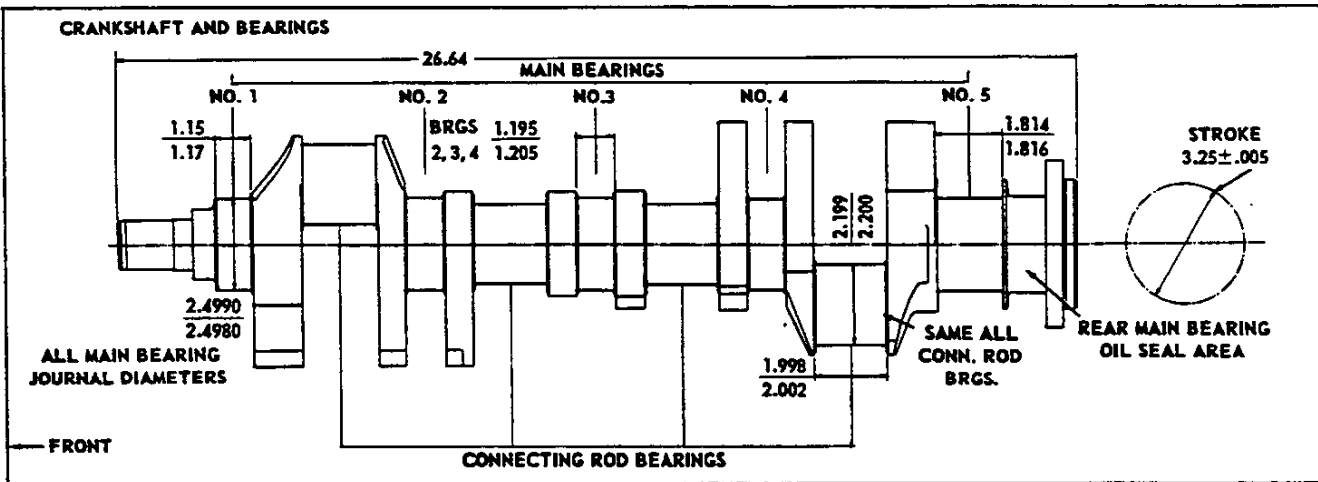

* - Steel backed aluminum alloy matrix with a thin lead alloy overplate except rear.
 10-15-58 • Revised 3-23-59
 32-ENGINES AND CLUTCHES

ENGINE - 348 cu in V-8	Turbo-Thrust	Super Turbo-Thrust	Turbo-Thrust Special		Super Turbo-Thrust Special
			HD PG	Synchromesh	

CAMSHAFT

Make	Own
Material	Cast alloy iron

CAMSHAFT BEARINGS

Material	Steel backed babbitt
Dimensions	
Bearing #1 thru 4	
Theoretical I. D.	1.8712
Effective length	.860
Projected area	1.609 sq. in.
Bearing #5	
Theoretical I. D.	1.8712
Effective length	.940
Projected area	1.759 sq. in.

CAMSHAFT DRIVE

Type	Chain and sprocket
Sprocket Material	
Crankshaft (drive)	Steel
Camshaft (driven)	Cast alloy iron
Timing Chain	
Make	Link Belt
No. of Links	48
Width	.88
Pitch	.500

VALVE MECHANISM

Type	Rocker arm, push rod actuated		
Lifters	Hydraulic	Mechanical	
Body material			
Foot	Cast alloy iron		
Sleeve	Steel		
Plunger	Steel		
Push rod	Steel		
Rocker Arm Ratio	1.75:1		
Valve Lash			
Inlet	Zero	.012	
Exhaust	Zero	.018	

VALVES

Inlet			
Material	High alloy steel (8645) *		
Stem to guide clearance	.0010-.0027		
Lift	.4005	.4076	.4058
Exhaust			
Material	High alloy steel (21-4N)*		
Stem to guide clearance	.0025-.0042		
Lift	.4119	.4139	.4120

VALVE SPRINGS

Compressed Length			
Valves closed	Inner	1.626 @ 78-86 lb	1.488 @ 20-24 lb
	Outer		1.696 @ 69-79 lb
Valves opened	Inner	1.230 @ 184-196 lb	1.06 @ 55-61 lb
	Outer		1.306 @ 159-169 lb
Free Length	Inner	Approx 2.0	1.84
	Outer		2.08

* - Valve faces aluminized with special cam and synchromesh transmission
 Inner and outer valve springs apply only to special cam and synchromesh transmission

348 CUBIC INCH V-8 ENGINE - Continued

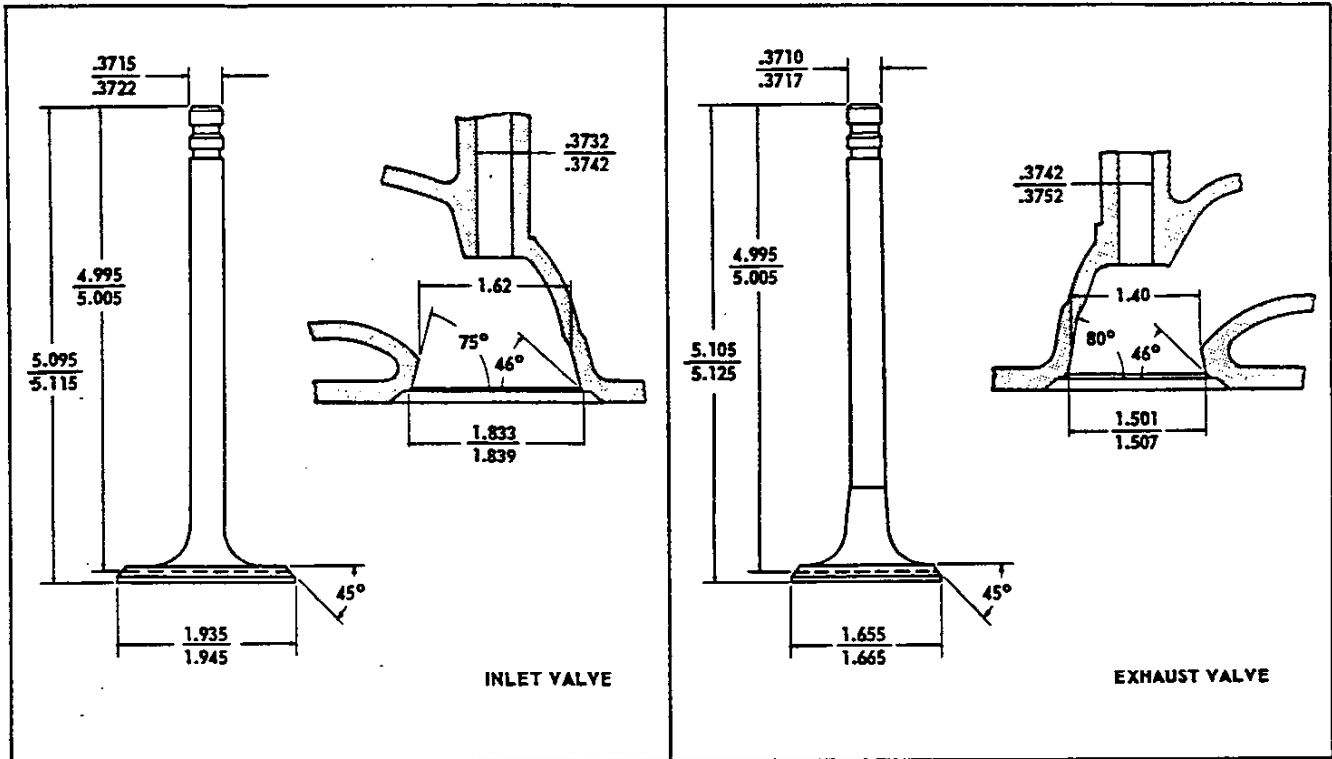

ENGINE - 348 cu in V-8	Turbo-Thrust	Super Turbo-Thrust	Turbo-Thrust Special	Super Turbo-Thrust Special
			HD PG	Synchromesh

VALVE SPRING DAMPERS

No. of Coils	3.56
Free Length	1.765

PISTONS

Material	Cast aluminum alloy	
Type		
Head	Peak roof	Half flat; half slanted downward 16°, notched
Skirt	Slipper, autothermic	
Weight (Oz.)	28.08	29.20
Top Land Clearance	.0325-.0367	
Skirt Clearance	.0006-.0010	
Groove Depth		
Compression ring	.2283-.2334	
Oil control ring	.2183-.2234	

PISTON PINS

Material	Alloy steel
Type	Rod shrunk fit to piston
Length	3.250-3.270
Diameter	.9895-.9898
Clearance in Piston	.00015-.00025
Direction of Offset	Major thrust side

COMPRESSION RINGS

No. per Piston	Two
Type	
Upper and lower	Thick wall, inside bevel or counterbore

ENGINE - 348 cu in V-8	Turbo-Thrust	Super Turbo-Thrust	Turbo-Thrust Special	Super Turbo-Thrust Special
			HD PG	Synchromesh

COMPRESSION RINGS - Continued

Material	Cast alloy iron		
Coating			
Upper ring	Flash chrome plate	.004-.007 chrome plating	
Lower ring	Wear resistant		
Width	.0770-.0780		
Gap	.015-.025		
Wall Thickness	.196-.206		

OIL RINGS

Type	Multi-piece (2 chrome rails and one spacer)		
No. per Piston	One		
Material			
Rails	Steel	Cast alloy iron	
Spacers	Stainless steel	Cast alloy iron (expanders)	
Coating			
Upper and lower rails	Chrome plated OD		
Width	.224-.232	.1855-.1865	
Gap	.015-.055	.013-.025	
Wall Thickness	.165-.171	.156-.162	

CONNECTING RODS

Material	Forged steel		
Length	6.134-6.136		
Bearings			
Material	Steel backed babbitt	Premium*	
Type	Precision, removable		
Effective length	.867		
Clearance	.0007-.0027		
End play	.008-.014		
Theoretical I. D.	2.2012		
Projected area	1.908 sq. in.		

TIMING DIAGRAM DATA

Valve Timing				
Inlet				
Opens - BTC	18°30'	33°	35°	
Closes - ABC	67°30'	74°	72°	
Exhaust				
Opens - BBC	68°30'	88°	76°	
Closes - ATC	25°30'	19°	31°	
Ramp				
Inlet				
Opening	.0034, 10°	.0066, 20°	.0059, 18°	
Closing	.0044, 13°			
Exhaust				
Opening	.0034, 10°	.0102, 31°	.0059, 18°	
Closing	.0044, 13°			
Tappet Lift				
Inlet	.2288	.2329	.2319	
Exhaust	.2354	.2365	.2354	

LUBRICATION SYSTEM

METHOD OF LUBRICATION

Type	Controlled full pressure
Main Bearings	Pressure
Connecting Rods	Pressure
Piston Pins	Splash

* - Steel backed aluminum alloy matrix with a thin lead alloy overplate

• Revised 6-22-59 • Revised 3-23-59 10-15-58

348 CUBIC INCH V-8 ENGINE - Continued

ENGINE - 348 cu in V-8	Turbo-Thrust	Super Turbo-Thrust	Turbo-Thrust Special	Super Turbo-Thrust Special
			HD PG	Synchromesh

METHOD OF LUBRICATION - Continued

Cylinder Walls	Pressure, jet cross spray
Camshaft Bearings	Pressure
Lifters	Pressure
Timing Gear	Nozzle sprayed

OIL PUMP

Type	Gear
Normal Oil Pressure	35 psi @ 2000 RPM
Intake Type	Fixed
Capacity (GPM, hot)	4.0-4.2 @ 1170-1200 RPM

OIL PRESSURE SENDING UNIT

Type	Electric
------	----------

CRANKCASE CAPACITY (quarts)

Dry	4.5
Refill	4.0

OIL FILTER

Availability	RPO 237	Production
Type	Full flow, spring loaded disc by-pass	
Capacity (dry)	1.0 quart	
Replacement Type	Element	

LUBRICANT GRADES AND TEMPERATURES

32°F and Above	SAE 20W, SAE 20, or 10W-30
0°F and Above	SAE 10W or SAE 10W-30
Below 0°F	SAE 5W or SAE 5W-20

CRANKCASE VENTILATION

Type	Road draft
------	------------

FUEL AND EXHAUST SYSTEM

FUEL PUMP

Make	AC
Type	Mechanical
Pressure Range	5.25-6.50 psi

MANIFOLD HEAT CONTROL

Type	Automatic
------	-----------

AIR CLEANER

Make	AC
Element	Paper

FUEL TANK

Capacity (gallons)	
Station Wagons and Sedan Delivery	17*
All others	20
Filler location	
Station Wagons and Sedan Delivery	In left rear quarter panel
All others	Center of body back lower panel at rear of hinged license plate

FUEL FILTER

Fuel Tank	Screen
Carburetor Inlet	Sintered bronze filter

*- 9-pass. Station Wagon has 18 gal. capacity.
10-15-58 • Revised 3-23-59
36-ENGINES AND CLUTCHES

ENGINE - 348 cu in V-8	Turbo-Thrust	Super Turbo-Thrust	Turbo-Thrust Special	Super Turbo-Thrust Special
			HD PG	Synchromesh

FUEL GAUGE

Make	AC
Type	Electric

EXHAUST SYSTEM

Type	Dual with resonators		
Exhaust Pipe			
O. D.	2.00	2.50	
Wall thickness	.0625		
Tail Pipe			
I. D.	1.81	2.0	
Wall thickness	.0598		

CARBURETORS

Regular Transmission				
Make	Carter	Rochester	Carter	Rochester
Model	3756677		3764593	
Front		7013015		7013973
Center		7013020		7013974
Rear		7013017		7013975
Automatic Transmission				
Make	Carter, Rochester	Rochester	Carter**	
Model	3756678, 7013006		3764593	
Front		7013015		
Center		7013016		
Rear		7013017		
Type	4 bbl., downdraft	2 bbl., downdraft	4 bbl., downdraft	2 bbl., downdraft
SAE Flange Size	1.25		1.50	1.25
Venturi ID by Make *	Carter	Rochester		Carter
Primary	1.06	1.13	Fr & Rr 1.19	1.25
Secondary	1.25	1.25	Center 1.25	1.56
Throttle Bore	1.4375		1.56 Pr, 1.68 Sec	1.4375
Choke	Automatic			

COOLING SYSTEM

GENERAL

Type	Pressure with full length water jacket around each cylinder
Shroud	Production

THERMOSTAT

Make	Harrison
Type	Pellet
Begins to Open @	167-172°F
Fully Opened @	192°F

RADIATOR

Make	Harrison
Type	Tube on center
Core Constant and Thickness	
Regular transmission	.25 x .55 x 1.75
Automatic transmission	PG-.22 x .55 x 1.75; TG-.20 x .55 x 1.75
Frontal Area	428 sq. in
Capacity (quarts)	
Less heater	21
With heater	22

RADIATOR CAP

Type	Pressure
Valve Opens @	Approx. 13 psi

* - Primary and Secondary data applies to 4-bbl carburetors only

** - Aluminum intake manifold on engines with synchromesh transmissions

1959 CHEVROLET PASSENGER CAR

• Revised 3-23-59 10-15-58
ENGINES AND CLUTCHES-37

348 CUBIC INCH V-8 ENGINE - Continued

ENGINE - 348 cu in V-8	Turbo-Thrust	Super Turbo-Thrust	Turbo-Thrust Special	Super Turbo-Thrust Special
			HD PG	Synchromesh

RADIATOR HOSE

Location	
Inlet	Thermostat housing to radiator
Outlet	Water pump to radiator
Type	Molded elbow
Inner Diameter	
Inlet	1.50
Outlet	1.75

FAN AND GENERATOR BELT

Number Used	One
Angle of "V"	37-44°
Pitch Line Length	57"
Width	.375-.385
Fan Pulley Size	7.00 P. D., 36° "V"

FAN

Number of Blades	4, staggered
Diameter	17.62
Ratio (fan to engine RPM)	.949:1

WATER PUMP

Type	Centrifugal
Capacity (GPM @ RPM)	53@ 4000
Drive	Fan belt
Bearing	Permanently lubricated double row ball

ELECTRICAL SYSTEM

GENERATOR

Make	Delco-Remy	
Model	1102097	1102059
Type	Two brush, shunt wound	
Drive	By fan belt	
Pulley Size	2.88 P. D.	4.00 P. D.
Generator RPM/MPH	Approx. 101	Approx. 73
Maximum Output		
Generator RPM (hot)	2450	2580
Engine RPM (hot)	1065	1554
Ratio (gen. to engine RPM)	2.3:1	1.66:1
Rating		
Amps	30	
Volts	12-15	

OPTIONAL GENERATOR EQUIPMENT

Model	
35 Amp (RPO 338)	1102114
40 Amp (RPO 326)	1105123 Medium duty
50 Amp (RPO 378)	1106985 Low cut-in

BATTERY

Make	Delco-Remy
Model	1980558
Voltage Rating	12
Number of Cells	6
Plates per Cell	11
Terminal Grounded	Negative
Location	Right front of engine compartment on radiator baffle
Capacity	61 amp. hr. @ 20 hr. rate

ENGINE - 348 cu in V-8	Turbo-Thrust	Super Turbo-Thrust	Turbo-Thrust Special	Super Turbo-Thrust Special
			HD PG	Synchromesh

OPTIONAL BATTERY EQUIPMENT (RPO 345)

Model	1980668
Capacity	70 amp. hr. @ 20 hr. rate

VOLTAGE AND CURRENT REGULATOR

Make	Delco-Remy
Model	1119234
Type	Vibrator
Cut-out - Relay	
Closing voltage @ generator RPM	11.8-13.5 @ 1300
Voltage Regulator	
Voltage	13.8-14.8
Current Regulator	
Amperes	27-33

STARTING MOTOR

Make	Delco-Remy		
Model			
Conventional	1107688		
Powerglide			
Turboglide	1107687		
Rotation (drive end view)	Clockwise		
-Test Conditions	Engine at operating temperature		
No Load Test			
Amps	65-100		
Volts	10.6		
RPM	3600-5100		
Drive			
Engagement type	Positive shift solenoid		
Number of teeth	9		
Gear ratio			
Flywheel to starter	18.6:1		
Flywheel face tooth width			
Regular and Powerglide	.4135		
Turboglide	.3435		

STARTING

Ignition Switch	
Positions	Locked Off, Unlocked Off, On, and Start
Starting Procedure	
Regular transmission	Turn ignition key to extreme right after placing shift lever in neutral and depressing clutch
Automatic transmission	Turn key to extreme right, selector in Park or Neutral

COIL

Make	Delco-Remy		
Model	1115083	1115111	1115114
Amperes Drawn			
Engine stopped	4.0		
Engine idling	1.8		

IGNITION TIMING

Initial Setting	4° BTC	12° BTC
Mark Location	Vibration damper	
Firing Order	1-8-4-3-6-5-7-2	

348 CUBIC INCH V-8 ENGINE - Continued

ENGINE - 348 cu in V-8	Turbo-Thrust	Super Turbo-Thrust	Turbo-Thrust Special	Super Turbo-Thrust Special
			HD FG	Synchromesh

SPARK PLUGS

Make	AC
Model	44N
Thread Size	14 MM
Gap	.033-.038
Torque	25 lb. ft.

DISTRIBUTOR

Make	Delco-Remy	
Model	1110948	1110919*
Breaker Gap	.016-.021	
Cam Angle	26-33°	
Breaker Arm Tension	19-23 oz.	
Spark Advance Data		
Centrifugal advance		
Begins (RPM)	700	
Maximum degrees @ RPM	24@4600	
Vacuum advance		
Maximum degrees @ "Hg	15@15.5	

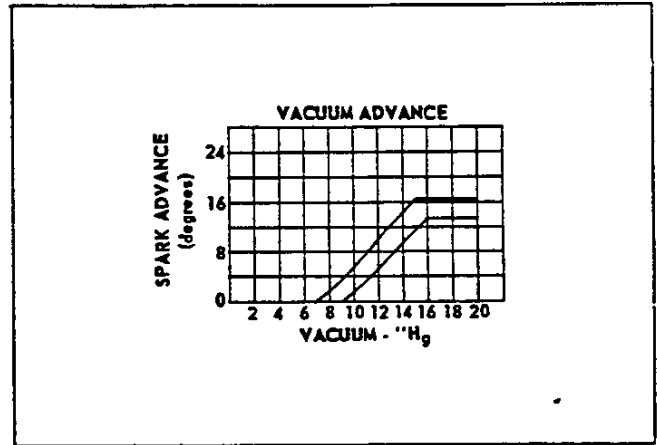
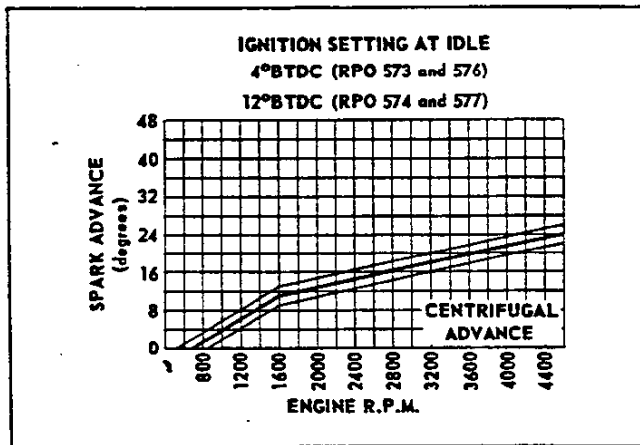

* - Dual Breaker points
10-15-58 • Revised 3-23-59
40-ENGINES AND CLUTCHES

DIAPHRAGM SPRING TYPE

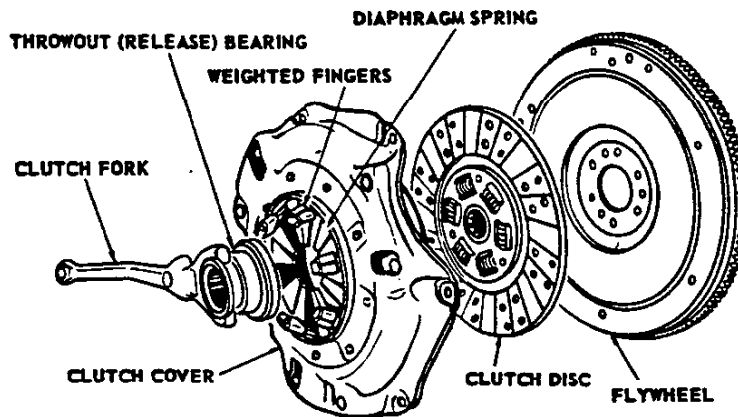

CLUTCHES

ITEM	Hi-Thrift 6 Cylinder		Turbo- Fire V8 3-Speed	Turbo Fire & Super Turbo- Fire V8 O'drive	Super Turbo- Fire V8 3-Speed	Ramjet Fuel Injection 3 and 4- Speed	Turbo- Thrust & Super Turbo- Thrust 3-4 Speed	
	3-Speed & O'drive	Heavy Duty Clutch						
Type	Single plate, dry disc	Semi-centrifugal, single plate, dry disc						
Rated torque cap. (lb. ft.)	245	342	295	323	313	323	370	
Drive	Strap							
Clutch Spring	Material	Spring steel, heat treated						
	Spring pressure	Through diaphragm spring						
	Total pressure	1450-1600	1575-1725	1475-1625	1575-1725	1575-1725	1775-1875	
Release	Diaphragm action, spring pivots on pivot ring							
Driven Disc	Type	One spring cushioned plate with two facings						
	Vibration dampers	6 cushion springs		12 springs	6 springs	12 cushion springs		
	Facing (two)	Material	Woven asbestos*				Woven asbestos**	
		O. D.	9.50	11.0	10.0	10.0	10.0	10.5
		I. D.	6.00	6.5	6.0	6.5	6.0	6.5
		Area (both facings)	85.22	123.70	100.53	90.72	100.53	90.72
Thickness		.135	.133	.135	.135	.135	.135	.133
Bear- ings	Clutch Release	Type, make	See anti-friction bearing chart					
	Pilot	Lub.	Packed for life					
		Make & no.	Chevrolet-412562					
		Type	Sintered powdered bronze bushing, oil impregnated					
		I. D.	.5915-.5925					
		O. D.	1.0935-1.0945					
		Width	.740-.760					
Lub.	Self							
Con- trols	Clutch fork type	Forged pivot mounted on ball						
	Pedal mounting	Pendant from brace on dash						
Fly- wheel	Material	Cast alloy iron						
	Wt. with ring gear (lb.)	30.90	31.25	28.22	29.35	28.22	27.50	
	Ring Gear	Type	Hot rolled steel, shrunk on flywheel					
		No. teeth	168					
Width & P. D.	.4110-.4160; 14.00 P. D.							
Clutch attach. to flywheel	6 Bolts							

* - Molded asbestos used optionally in Hi-Thrift 6 cylinder 3-speed & overdrive clutches
 ** - Premium grade

TRANSMISSIONS

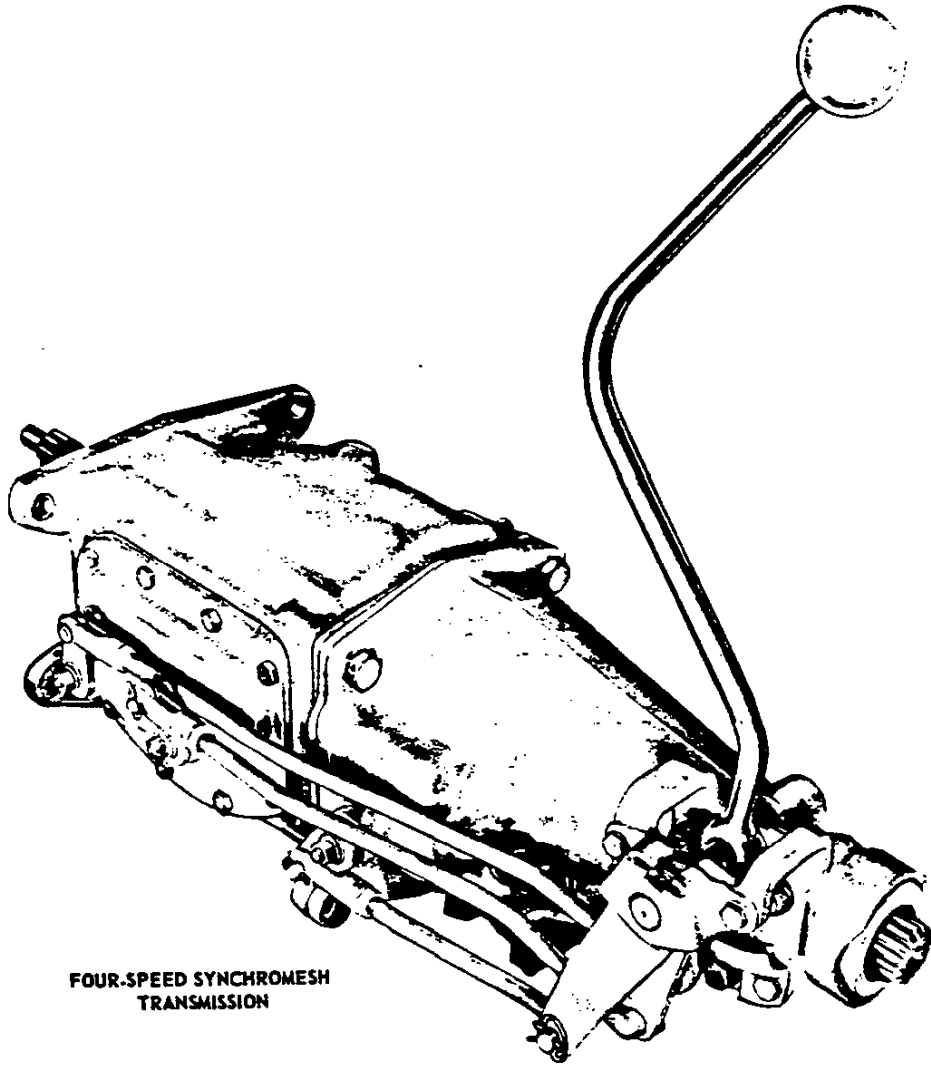

**FOUR-SPEED SYNCHROMESH
TRANSMISSION**

THREE AND FOUR-SPEED CONVENTIONAL TRANSMISSIONS	3
OVERDRIVE UNIT	4
POWERGLIDE	4
TURBOGLIDE	6



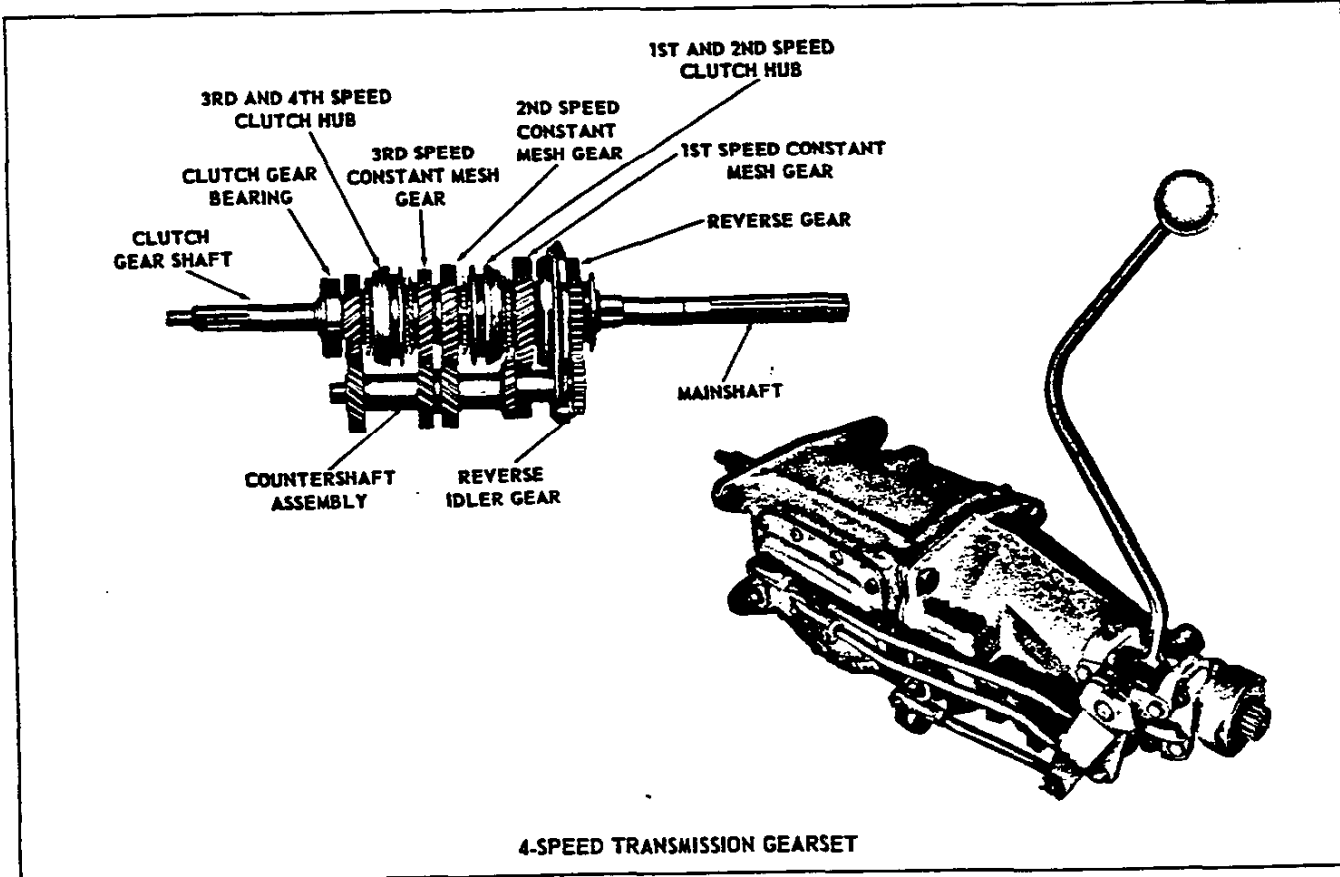
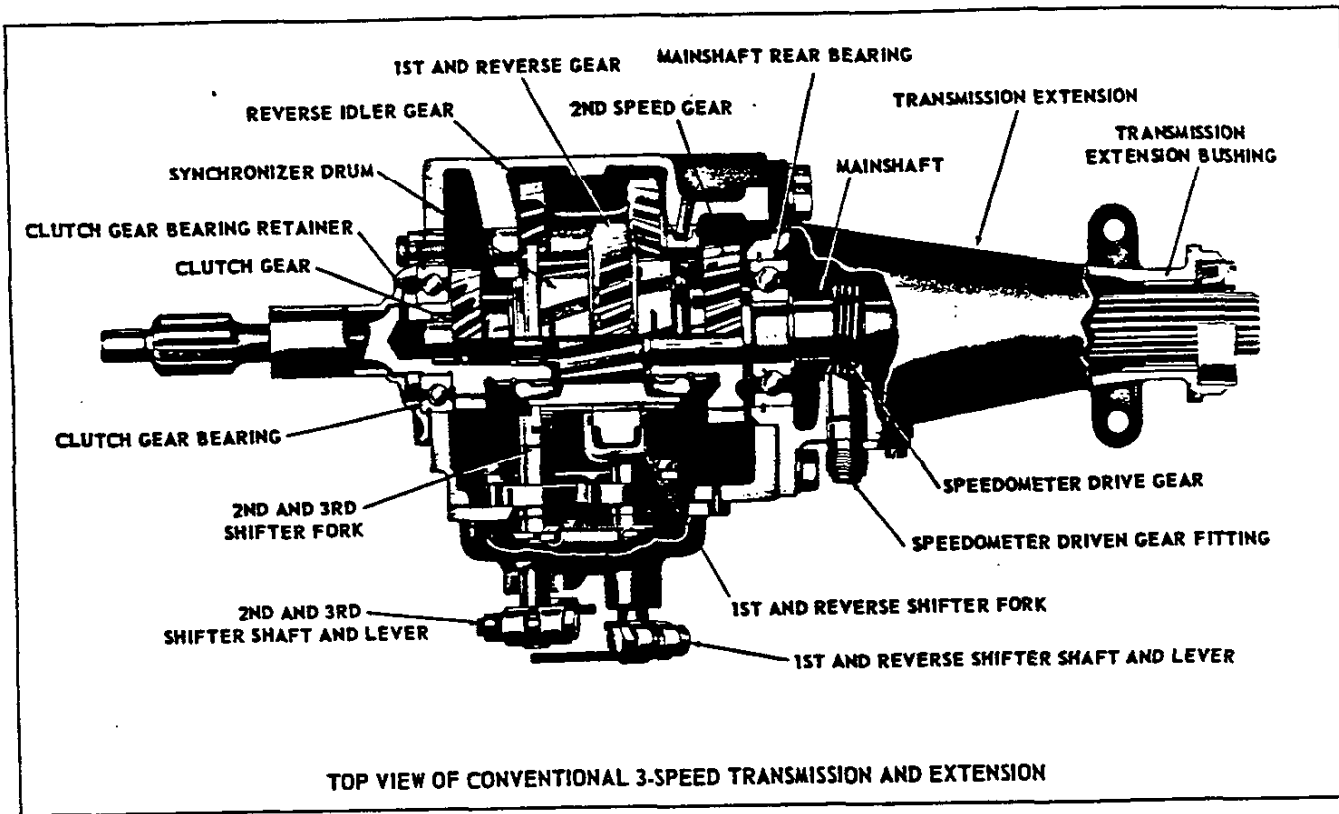

THREE AND FOUR-SPEED CONVENTIONAL TRANSMISSIONS

ITEM		235 cu. in. 6 cyl.	283 cu. in. V-8	348 cu. in. V-8	RPO (V-8's only)+	
Make		Own, synchromesh, manual shift				
Type		3-Speed			4-Speed	
Gearshift	Control	Remote				
	Type	Lever				
	Location	On steering column			On floor	
Gears	Type	All helical				
	Material	Forged steel, hardened				
	Synchronization	2nd and 3rd			1st, 2nd, 3rd, 4th	
	Constant mesh gears	2nd			1st, 2nd, 3rd	
	Sliding gears	1st and reverse			Reverse	
	Gear Ratios	First	2.94:1	2.47:1	2.20:1	
		Second	1.68:1	1.53:1	1.66:1	
Third		Direct		1.31:1		
Fourth		Direct		Direct		
Reverse		2.94:1	2.80:1	2.26:1		
Speedometer Gears	Tooth pitch	28				
	Teeth	Drive	8			
		Driven	21	20	@	
Lubricant.	Type recommended	SAE 90 transmission multi-purpose or mineral oil lubricant				
	Capacity	2 pints			3 pints	
Oil seal (transmission extension)		Steel encased double seal of spring loaded synthetic rubber and felt				
Anti-friction bearings		See anti-friction bearing chart				

* - Fuel Injection and Turbo-Thrust Engines only.

@ - 21 driven teeth for Fuel Injection and 20 for Turbo-thrust engines.

+ - This transmission also optional on Corvette.

OVERDRIVE UNIT

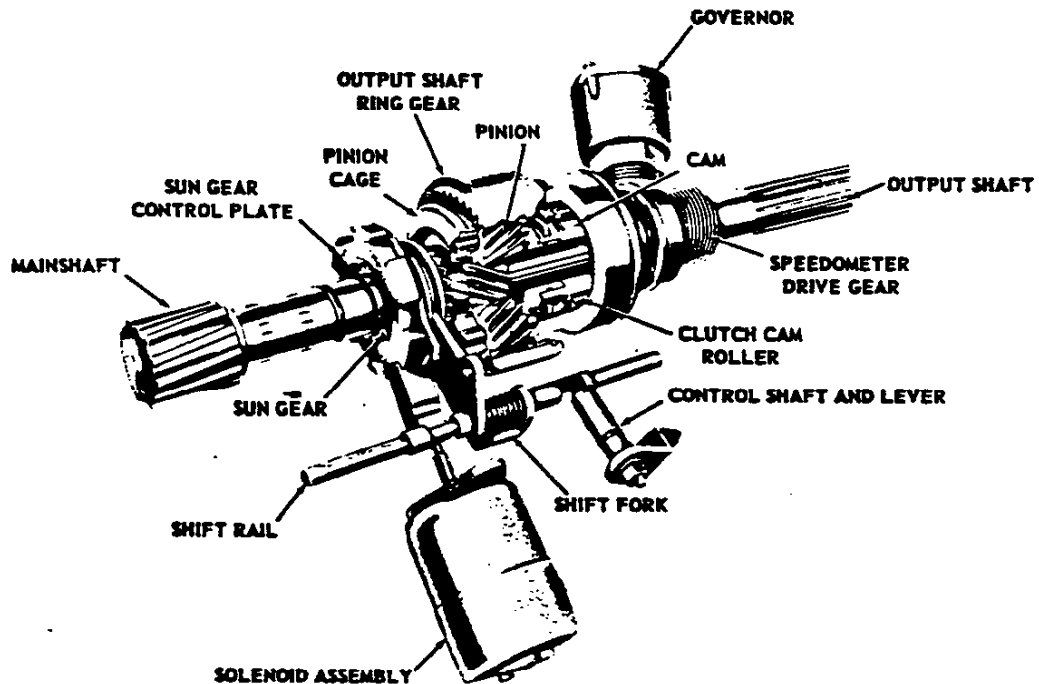

OVERDRIVE UNIT (RPO 315)

GENERAL DATA

Type ----- 3-speed synchro-mesh with 3-pinion planetary drive unit. The drive unit with its integral mainshaft replaces the mainshaft and extension of the regular 3-speed transmission.

Lockout Switch ----- Manually controlled by "pull type" cable located under instrument panel to right of steering column. With handle fully extended, overdrive is locked-out.

Kickdown Switch ----- On carburetor, actuated by accelerator pedal.

Minimum Cut-in Speed ----- 27-30 MPH

Cut-out Speed ----- 18-22 MPH

GEAR RATIOS

Overdrive Unit	Locked Out	Locked In
First	2.94:1	2.058:1
Second	1.68:1	1.176:1
Third	1.00:1	0.700:1
Reverse	2.94:1	@

SPEEDOMETER GEARS

Tooth Pitch ----- 30

Teeth-driving and Driven ----- 8 & 24

LUBRICANT

Type ----- SAE 90 transmission or mineral oil

Capacity

Transmission ----- 2 pints

Overdrive unit ----- 1 pint

Total ----- 3 pints

POWERGLIDE (RPO 313)

GENERAL DATA

Make & Type ----- Own, automatic hydraulic torque converter with planetary gear system for reverse and low; converter maximum torque ratio (at stall) ----- 2.1:1

Total Transmission Torque Multiplication (converter planetary gear ratio)

Maximum overall transmission ratio ----- 3.82:1

Low gear drive or low range ----- 3.82:1 to 1.82:1

Reverse range ----- 3.82:1 to 1.82:1

Oil Type ----- Automatic transmission fluid, type A Suffix "A"

Oil Capacity ----- 10-1/2 quarts; refill 4-1/2 qts.

Oil Cooler ----- Integral with radiator assembly and connected to trans. by inlet and outlet pipes

Selector Lever

Location ----- On steering column

Operation ----- Actuates manual valve in hydraulic control system

Positions (indicated in quadrant on steering column) ----- Five; (left to right), Park - Reverse - Neutral - Drive - Low

Parking Lock

Type ----- Pawl and gear

Parking Lock (Cont'd.)

Operation ----- Applied by selector lever through positive linkage

Flywheel --- Steel stamping with welded-on ring gear

Drive Range - Representative Shift Points:

Accelerator pedal position:	Miles per hour	
	Upshift	Downshift
Closed throttle	13-15	10-13
Throttle at detent	30-45	14-18
Full throttle	48-53	45-50

HYDRAULIC TORQUE CONVERTER

Type ----- Three element

Driving Member (pump) ----- Sheet metal, multi-vane type, spot weld to torque converter housing. The housing cover is bolted to the flywheel

Driven Member (Turbine) -- Sheet metal, multi-vane type supported by torque converter housing cover. Turns independently of housing Splined to input shaft.

Reaction Member (stator)----- Aluminum air foil type supported on a stationary sleeve by an overrunning clutch of cam and roller design.

HIGH CLUTCH

Type ----- Multiple-disc

Discs ----- Driving; number and type Four, steel with cork and paper facings, bonded.

Driven; number and type ----- Five, steel

PLANETARY GEAR UNIT

Type ----- Compound planetary

Gear Ratios

Cruising range ----- 1:1 (Direct drive)

Low range ----- 1.82:1

Reverse ----- 1.82:1

Low brake band ----- Double-wrapped design (linked circular segments)

Low band servo

Type ----- Piston, one release spring

Reverse brake band ----- Single strap

Reverse band servo

Type ----- Piston with release spring and inner cushioning spring.

HYDRAULIC CONTROLS

Manual Valve

Type ----- Spool

Pressure Regulator Valve:

Type ----- Spool

Pressure range (PSI)	V-8	6-Cyl.
Drive and Neutral*	50-120	50-77
Low and Park*	120	77
Reverse	98-250	96-181

Governor

Type ----- Centrifugal

Drive ----- From transmission output shaft

Location ----- Accessible from rear of transmission left side

Operation ----- Regulates pump oil pressure to automatic shifting control valve body

@ - Overdrive does not function in Reverse.

* - At maximum idling speed of 425 RPM in drive.

HEAVY DUTY POWERGLIDE

This transmission used with 348 Cubic Inch Engine (4-barrel carburetor with special camshaft) is same as regular production except for following differences:

CONVERTER COVER

Type ----- 33 bolt

HIGH CLUTCH

Type ----- Five plate

GOVERNOR

Type ----- Modified to raise shift point
from 4700 rpm to 5400 rpm

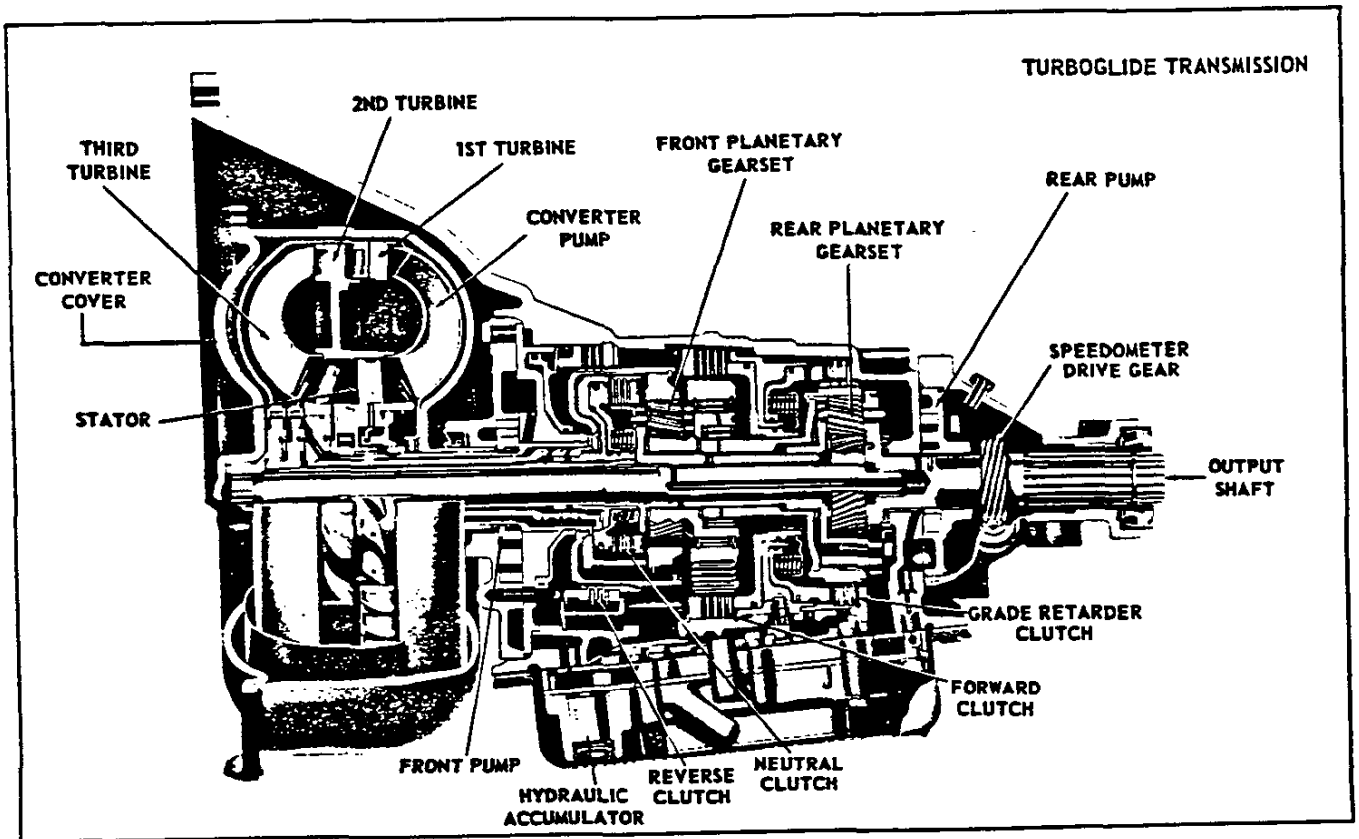
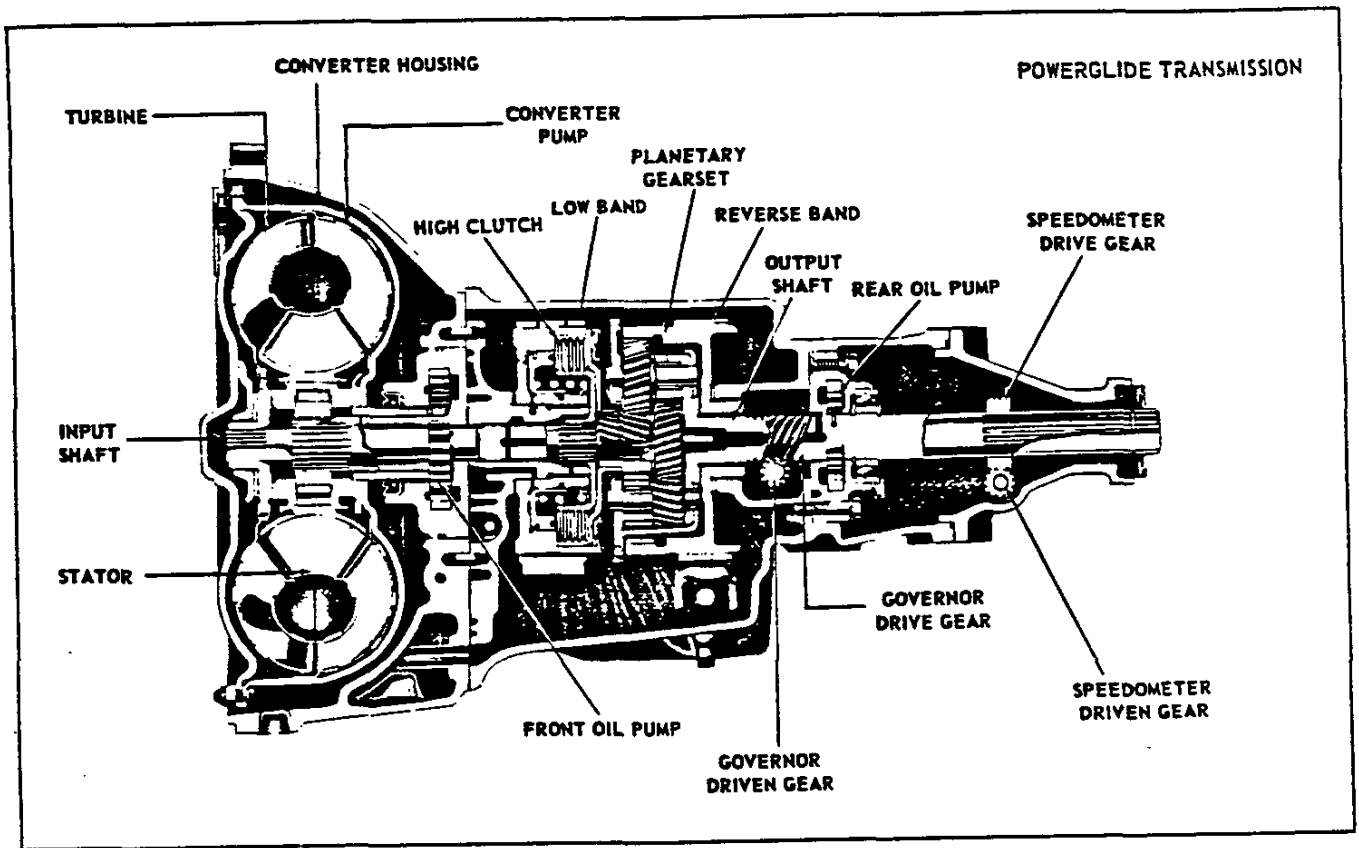

TURBOGLIDE (RPO 302)

GENERAL DATA

Make ----- Own
 Type ----- Triple turbine hydraulic torque converter with first turbine and second turbine driving output shaft through planetary gearsets. Third turbine drives output shaft directly. Planetary gearsets also provide Reverse and Grade Retarder operation. Two position stator vanes provide extra multiplication.
 Drive Position Torque Multiplication (maximum)
 Low stator angle ----- 3.8
 High stator angle ----- 4.3
 Reverse Position Torque Multiplication ----- 3.1
 Oil Type ----- Type A
 Suffix "A"
 Oil Capacity
 Dry ----- 19 pts.
 Refill ----- 4 pts.
 Oil Cooler ----- Integral with radiator assy. and connected to transmission by inlet and outlet pipes
 Selector Lever
 Location ----- On steering column
 Operation ----- Actuates manual valve in hydraulic control system
 Quadrant Positions (on stg. column)
 Number ----- Five
 P ----- Park
 R ----- Reverse
 N ----- Neutral
 D ----- Drive
 GR ----- Grade Retarder
 Line Pressures
 Park ----- 80 PSI
 Reverse ----- 80-200 PSI
 Neutral ----- 80 PSI
 Drive ----- 80-200 PSI
 Grade Retarder ----- 80 PSI

HYDRAULIC TORQUE CONVERTER

Type ----- Five element
 Driving Member (pump) ----- Sheet metal, multi-vane type, spot-welded to torque converter housing. Housing cover is bolted to the flywheel.
 Driven Members
 First turbine ----- Die cast aluminum axial flow air foil type, drives rear sun gear shaft
 Second turbine ----- Die-cast aluminum axial flow air foil type, pinned and press fit to drive front ring gear shaft.

Third turbine ----- Sheet metal, multi-vane type, drives output shaft
 Reaction member (stator) ----- Magnesium air foil type with dual pitch, controlled by accelerator position.

CLUTCHES

Type ----- Multiple-disk
 Material
 Driven plates --- Faced with non-metallic compound
 Pressure plate ----- Sintered iron
 Reaction plates ----- Steel
 Return Spring
 Forward & Grade Retarder ----- Radial row of coil springs
 Reverse ----- Diaphragm type
 Active Faces
 Forward ----- Eight
 Reverse and neutral ----- Six

PLANETARY GEAR UNIT

Material ----- Steel
 Number of Pinions
 Front ----- Six
 Rear ----- Three
 Drive Gear Ratios
 Drive position
 Front planetary gear set ----- 1.63:1
 Rear planetary gear set ----- 2.67:1
 Gear Retarder position
 Rear planetary gear set ----- 2.67:1

PARKING LOCK MECHANISM

Type ----- Spring loaded wedge
 Operation ----- Applied by selector lever through positive linkage

SPEEDOMETER GEARS *

Teeth
 Drive gear ----- 8
 Driven gear
 283 cu. in. engine ----- 20
 348 cu. in. engine ----- 18

* - Also applicable to Powerglide transmission

CHASSIS

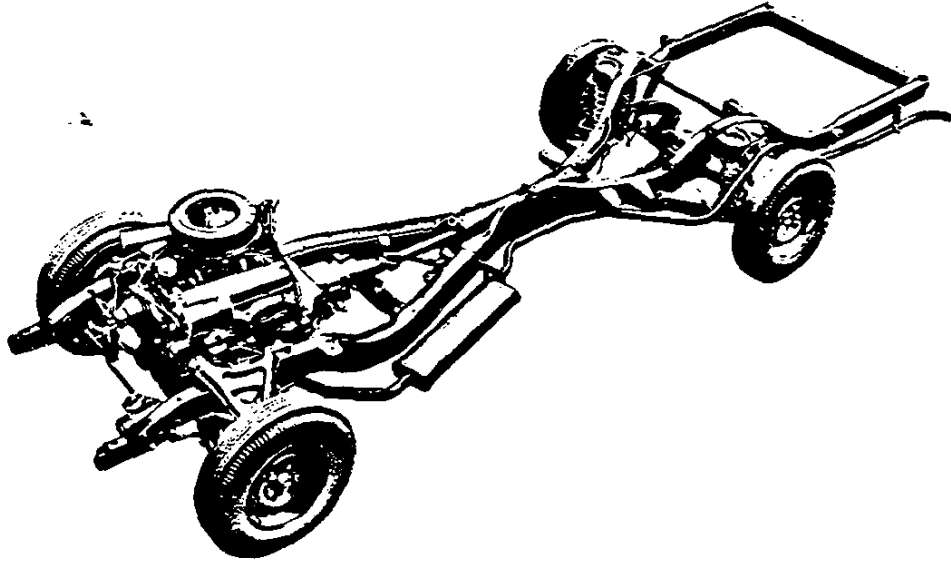

FRAME	2
FRONT SUSPENSION	2
STEERING	4
REAR SUSPENSION	5
AIR SUSPENSION	6
REAR AXLE	7
POSITRACTION	8
BRAKES	9
DRIVELINE	10
WHEELS & TIRES	10
ELECTRICAL COMPONENTS	11

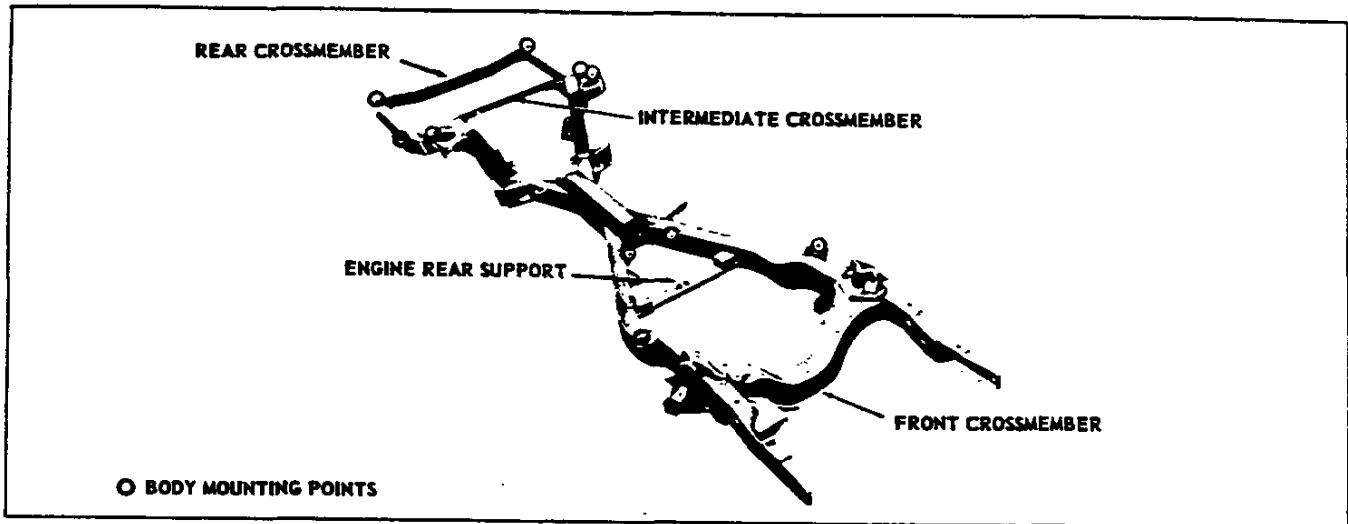

FRAME

GENERAL

Make ----- Various
 Type ----- X-design
 Material ----- Hot rolled, pickled steel
 Material yield point ----- 33000 lb./sq. in.
 Material elongation ----- 25% minimum in 2 inches
 Sidemember Section:
 Modulus (in³) ----- 1.90.
 Moment of inertia ----- 4.27

Maximum Overall Length (Approx.) ----- 195.3
 Maximum Width (over sidemembers at rear cross-
 member) ----- 47.50
 Convertible Frame ----- Steel plates welded to top
 and bottom of sidemember and center beam.
 Body Mounts:
 Total, all models ----- 12
 Mounting locations ----- See frame diagram

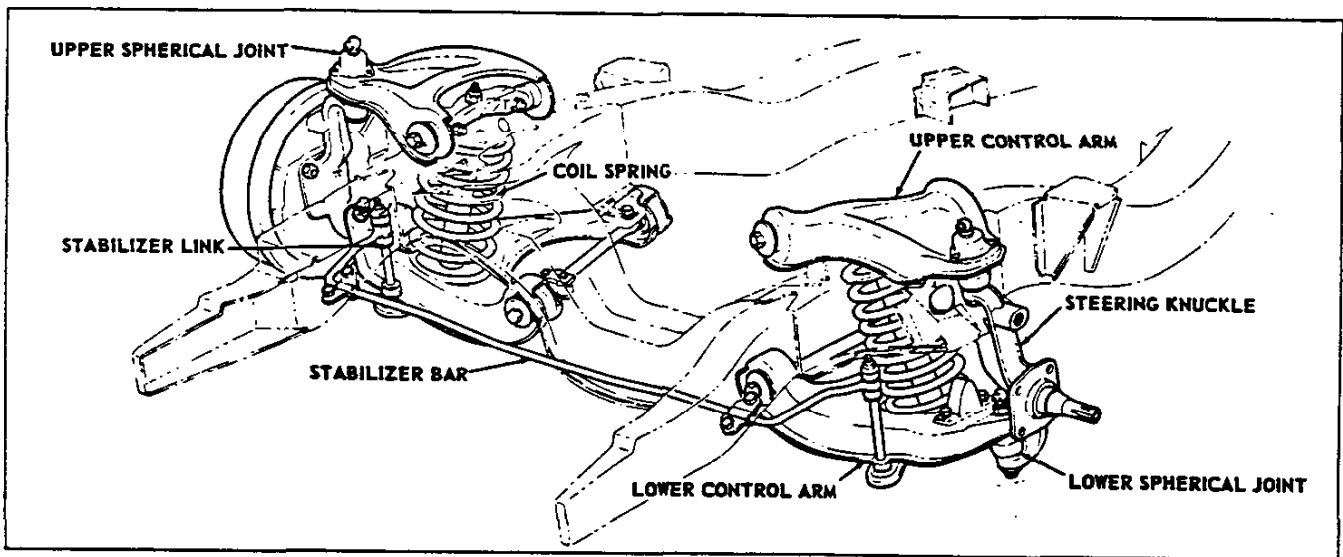

FRONT SUSPENSION

GENERAL

Make ----- Own
 Type ----- Independent, combining long and short
 control arms with spherical joints and coil springs.

Wheel to Spring Ratio ----- 1.87:1

WHEEL TRAVEL

Vertical, Loaded Conditions
 Metal to Metal ----- 3.90 up, 4.54 down

SPRING BUMPERS

Material and number ----- Rubber, 2 each RH & LH
 Location ----- On topside of lower control arm
 and topside of frame crossmember.

SHOCK ABSORBERS

Make ----- Delco
 Type ----- Direct, double acting hydraulic
 Mounting ----- Vertically from lower control arm through coil spring to fr. suspension crossmember.
 Model Number ----- 506G-52A; 506G-63A
 Valve Code ----- C3.75J8-8-8/OXJ; C4J8-8/OXJ
 Piston Diameter and Travel ----- 1.00; 4.9375

Lower ----- Forged seat and stamped socket, each cup shaped, and bonded by grease tight peening.

Lubrication ----- Through high pressure fitting at top of each socket.

STEERING KNUCKLE

Type ----- Forged steel with integral brake cylinder mounting, detachable steering arms.
 Spindle Diameters:
 At inner bearing ----- 1.2492-1.2497
 At outer bearing ----- .7491-.7496

WHEEL BEARINGS

Wheel bearing lubricant --- High melting point grease

SPHERICAL JOINTS

Type ----- Ball stud and socket in assembly, self adjusting for wear.
 Number ----- 1 each, upper and lower; LH & RH
 Ball Stud:
 Material ---- Hot rolled steel hardened and ground
 Ball spherical diameter:
 Upper ----- 1.304-1.308
 Lower ----- 1.246-1.250
 Bearings ----- Non-metallic; molded, phenolic impregnated fabric.

STABILIZER BUSHINGS

Type and number ----- Pre-loaded rubber; 8 (2 each pivot shaft, left hand and right hand).
 Material ----- Steel encased rubber
 Size:
 Upper ----- .670-.677 x 1.76 approximately
 Lower ----- .737-.744 x 2.08 approximately
 All except 1111-19-21;11-1270;11-1280;1511-19-37-39

Seals:
 Upper ----- Rubber with bonded nylon bushing
 Lower ----- Rubber with steel cover
 Socket:

STABILIZER BAR

Type ----- Link
 Diameter ----- 0.6875
 Bushings ----- Rubber; 10 (1 each at frame side rail and 4 each left hand and right hand at link attachment).
 Usage- All except 1111-19; 11-1270; 11-1280; 1511-19

Type and material:
 Upper ----- Two cup-shaped steel stampings bonded by grease-tight weld with rubber type loading ring to compensate for wear.

FRONT WHEEL ALIGNMENT:

Caster ----- 0°±30'
 Camber ----- +30°±30'
 Steering axis inclination ----- 7°11'
 Toe-in (per wheel) ----- 1/16-1/8

SPRINGS

Application	Series	1100-1200						1500-1600					1700-1800					
		11	15	19	21	35	70	80	11	19	35	39	45	19	35	37	39	67
6 Cylinder	Manual	C	A	C	C	A	B	B	C	C	A	A	A	A	A	A	A	E
	Powerglide	D	E	D	D	E	B	B	D	D	E	E	E	E	E	E	E	J
V-8 283 cu. in	Manual or Turboglide	A	A	A	A	A	B	B	A	A	A	A	A	A	A	A	A	E
	Powerglide	E	E	E	E	E	B	B	E	E	E	E	E	E	E	E	E	J
	Air Powerglide	F	F	F	F	F	-	K†	F	F	F	F	F	F	F	F	F	G
V-8 348 cu. in	Cond Turboglide	J	J	J	J	J	-	D†	J	J	J	J	J	J	J	J	J	F
	Manual or Turboglide	E	E	E	E	E	-	-	E	E	E	E	E	E	E	E	E	J
	Powerglide	J	J	J	J	J	-	-	J	J	J	J	J	J	J	J	J	F
	Air Powerglide	G	G	G	G	G	-	L†	G	G	G	G	G	G	G	G	G	H
Cond Turboglide	F	F	F	F	F	-	K†	F	F	F	F	F	F	F	F	F	G	

† 1280 only

Data

Application	A	B	C	D	E	F	G	H	J	K	L	
Part No	3741497	3746851	3746852	3746853	3758760	3758763	3759987	3764408	3764582	3752906	3752908	
Type	Right hand helix											
Material	High alloy steel											
No. coils	867-1011		7.67-9.11			8.67-10.11				7.67-9.11		
Wire Dia	.630		.664			.630		.648			.664	
Outside dia	5.062		5.130			5.062		5.098			5.130	
Pitch dia	4.432		4.466			4.432		4.450			4.466	
Ht	Free	17.05	15.03	15.32	15.53	17.33	17.08	17.27	17.56	16.82	15.76	15.98
	Working	10.30@ 1855#	10.30@ 1750#	10.30@ 1855#	10.30@ 1935#	10.30@ 1935#	10.30@ 2100#	10.30@ 2160#	10.30@ 2250#	10.30@ 2020#	10.30@ 2020#	10.30@ 2100#
HT-curb wt	10.88	10.68	10.72	10.72	11.10	10.83	11.27	11.13	11.24	10.64	10.67	
Cap @ grd*	1095		1130			1240		1270		1320		
Deflection rate	275 lb/in		370 lb/in			275 lb/in		310 lb/in			370 lb/in	
	96 lb/in		129 lb/in			96 lb/in		108 lb/in			129 lb/in	

* - Includes unsprung weight

• Revised 6-22-59 • Revised 3-23-59 10-15-58 CHASSIS-3

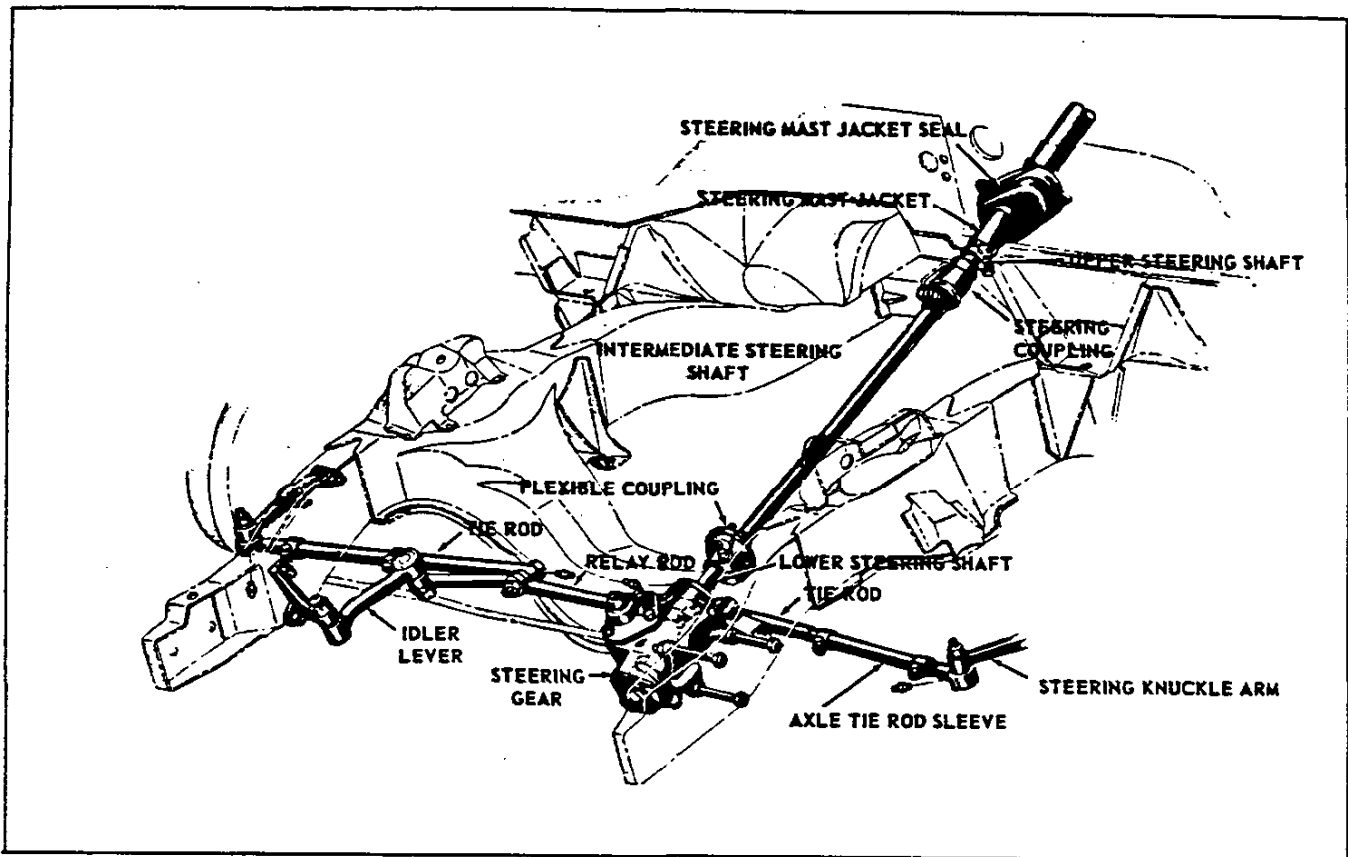

STEERING

STEERING GEAR

Make	Saginaw
Type	Semi-reversible recirculating ball
Gear Ratio	24:1
Overall Ratio (Approx.)	28:1
Steering Mainshaft Diameter750
Steering Column Diameter	2.01
Steering Wheel Diameter	17.00
Turning Diameters	
Outside front:	
Right and left wall to wall	43.6 Ft.
Right and left curb to curb	40.8 Ft.
Inside rear:	
Right and left wall to wall	23.2 Ft.
Right and left curb to curb	24.5 Ft.
Outside Wheel Angle with Inside Wheel@20°	17°54'
Number of Wheel Turns:	
To steering gear stop	6.14
To wheel stops on control arm	5.80

LINKAGE

Type	Relay
Location	To front of wheels
Tie Rods	2

POWER STEERING (RPO 324):

Make	Saginaw
Type	Hydraulic
Pump:	
Type	Vane
Mounting	On rear of generator
Drive	From splined extension of generator drive shaft.
Maximum pump pressure	750-800 PSI
Fluid capacity	1.5 pts.
Generator:	
Make	Delco-Remy
Model	1102115
Pulley size (pitch diameter)	3.32, 36° V"
Ratio (generator to engine)	2.00:1
Belt size:	
Reg. prod. 6-cyl. eng.--	.310 x 44.50 pitch length
Reg. prod. 8-cyl. eng.--	.310 x 56.00 pitch length
Power Application	Double acting piston in power cylinder is actuated by control valve after approximately 3 pounds of pressure is exerted at the steering wheel.
Overall Ratio	24:1
Gear Ratio	20:1

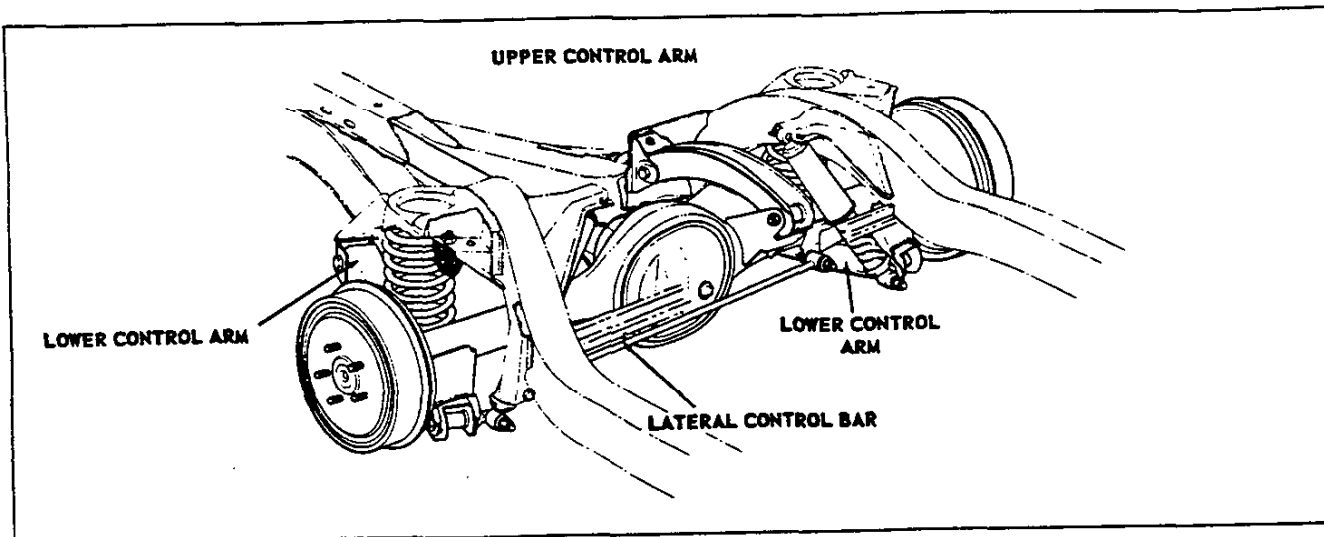

REAR SUSPENSION

GENERAL

Make ----- Own
 Type ----- Four-link with an upper control arm, a lateral control bar, and 2 lower control arms. Coil springs.

WHEEL TRAVEL

Vertical, Loaded Conditions
 Metal to Metal ----- 4.32 up, 5.56 down
 Wheel to Spring Ratio ----- 1.51:1

CONTROL ARMS

Mounting:
 Upper ----- Pivotaly attached at forward end to frame right sidemember, and on axle housing banjo at rear.
 Lower ----- Pivotaly attached at forward ends to frame brackets and at rear to axle housing brackets.

SUSPENSION BUMPERS

Material and number ----- Rubber, 1 each RH & LH
 Location ----- On underside of frame at top of kick-up

LATERAL CONTROL BAR

Mounting ----- Pivotaly attached at right side of axle housing banjo and at frame left sidemember.
 Diameter ----- .750
 Length (℄ to ℄ of bushing) ----- 31.45

SHOCK ABSORBERS

Make ----- Delco
 Type ----- Direct, double acting hydraulic
 Mounting ----- Short cantilever brackets welded to frame sidemember at upper end and to rear spring anchor plate at lower end.
 Model Number ----- FD503W 69A; FD503W 54A
 Valve Code ----- C3, 57G8-8/OXJ; C4.25C8-8/DXJ
 Piston Diameter and Travel ----- 1.00; 8.4375

SPRINGS

Series		1100-1200							1500-1600					1700-1800											
Models		11	15	19	21	35	70	80	11	19	35	39	45	19	35	37	39	67							
Standard	6 Cyl	D	C	D	D	C	E	E	D	D	C	D	A	B	C	B	B	D							
	All V8	B	C	B	B	C	E	E	B	B	C	B	A	B	C	B	B	D							
Heavy Duty	6 Cyl	E	A	E	E	A	F	F	E	E	A	E	-	E	A	E	E	E							
	All V8	E	A	E	E	A	F	F	E	E	A	E	-	E	A	E	E	E							
Model Application		A			B				C			D		E			F								
Part Number		3744364			3752910				3765137			3754513		3758764			3764330								
Make and Type		Own, right hand helix																							
Material		High alloy steel																							
Number of Coils		7.8, 9.41			8.8, 10.41				7.8 active, 9.41 total																
Wire Diameter		.681			.583				.648					.587					.630						
Outside Diameter		5.000			4.804				4.934					4.812					4.898						
Pitch Diameter		4.319			4.221				4.286					4.225					4.268						
Height	Free	14.73			16.33				16.02					15.44					14.70			15.14			
	Working	9.55@			9.55@				9.55@					9.55@					9.55@			9.55@			
Height Under Curb Wt		2330#			1560#				2200#					1560#					1750#			1900#			
Height Under Curb Wt		10.58			9.55				10.52					9.55					9.80			10.24			
Capacity at Ground*		1700			1195				1615					1195					1315			1415			
Deflection		At spring			450 lb/in				230 lb/in					340 lb/in					265 lb/in					340 lb/in	
Rate		At wheel			175 lb/in				101 lb/in					145 lb/in					112 lb/in					145 lb/in	

* - Includes unsprung weight

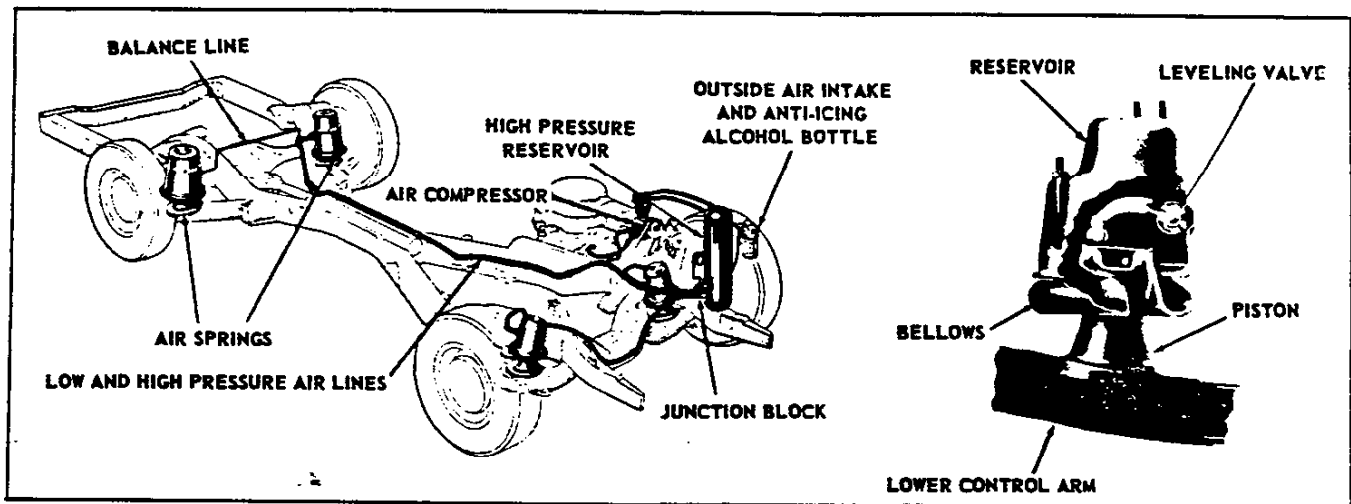

AIR SUSPENSION

GENERAL

Make ----- Chevrolet
 Type and Description ----- Level Air, with air springs at each wheel and 3 leveling valves. Air supply system consisting of an engine driven air compressor, high pressure accumulator, junction block, anti-icing bottle integral with make up air intake.

Low Pressure from Air Springs ----- 0 to 15 PSI
 With manual valve closed ----- 0 to 140-165 PSI

HIGH PRESSURE ACCUMULATOR

Size ----- 19.18 high, 5.38 dia., 360 cu.in. capacity
 Operating Pressure ----- 220-250 PSI
 Minimum Burst Pressure ----- 1000 PSI
 Location ----- Inside left hand radiator support filler panel.

AIR SPRINGS

Reservoir:

Material ----- Stamped sheet steel
 Number ----- One each wheel
 Location ----- On brackets welded to frame sidemembers with lower ends covered with fabric-reinforced rubber bellows.

Leveling Valves:

Orifice diameters:

Right & left front reservoir:
 Inlet & exhaust ----- .020
 Left rear reservoir:
 Inlet ----- .031
 Exhaust ----- .042
 Balance line orifice ----- .020
 Dead band (design) ----- 13/8

Piston:

Material ----- Hot rolled steel
 Number ----- One each wheel
 Location ----- Welded to suspension lower control arms.

Bellows:

Material ----- Fabric reinforced rubber
 Number ----- One each wheel
 Maximum diameter ----- 7.350
 Diameter at bead ----- 6.208

AIR COMPRESSOR

Type ----- Air cooled, single cylinder, reciprocating
 Capacity -- ----- 800-1400 cu.in./min. @ 1250 RPM
 ----- 1350-2400 cu.in./min. @ 2500 RPM
 Max. Pressure ----- Relief valve set at 220-250 PSI
 Pulley Ratio to Engine ----- 1.25:1
 Pulley Size ----- 3/8 40°V-belt

AIR SUPPLY SYSTEM PRESSURES

High Pressure to Air Springs ----- 220-250 PSI

JUNCTION BLOCK

Function ----- Combines into one assembly. separate manifold functions for high and low pressure systems, all relief valves, and a manual low pressure shut-off valve for special purposes.

High Pressure Relief ----- 220-250 PSI
 Low Pressure Relief ----- 15 PSI
 With manual valve closed ----- 140-165 PSI
 Location ----- Top of left hand frame sidemember behind radiator support filler panel.

ANTI-ICING BOTTLE

Material ----- Glass
 Size ----- 5.06 high, 3.18 dia.
 Capacity ----- One pint
 Cap Material ----- Aluminum die casting
 Location ----- On left hand front fender inner skirt

AIR CLEANER

Filter Element Material ----- Nylon fabric
 Screen Material ----- No. 14 galvanized wire

SHOCK ABSORBERS

Front:

Make ----- Delco
 Type ----- Direct, double acting, hydraulic
 Mounting ----- On lower suspension control arm and bracket welded to top of frame sidemember.
 Piston dia. and travel ----- 1.00 x 6.6875

Rear:

Make ----- Delco
 Type ----- Direct, double acting, hydraulic
 Mounting ----- On lower suspension control arm and bracket welded to top of frame sidemember.
 Piston dia. and travel ----- 1.00 x 8.4375

10-15-58

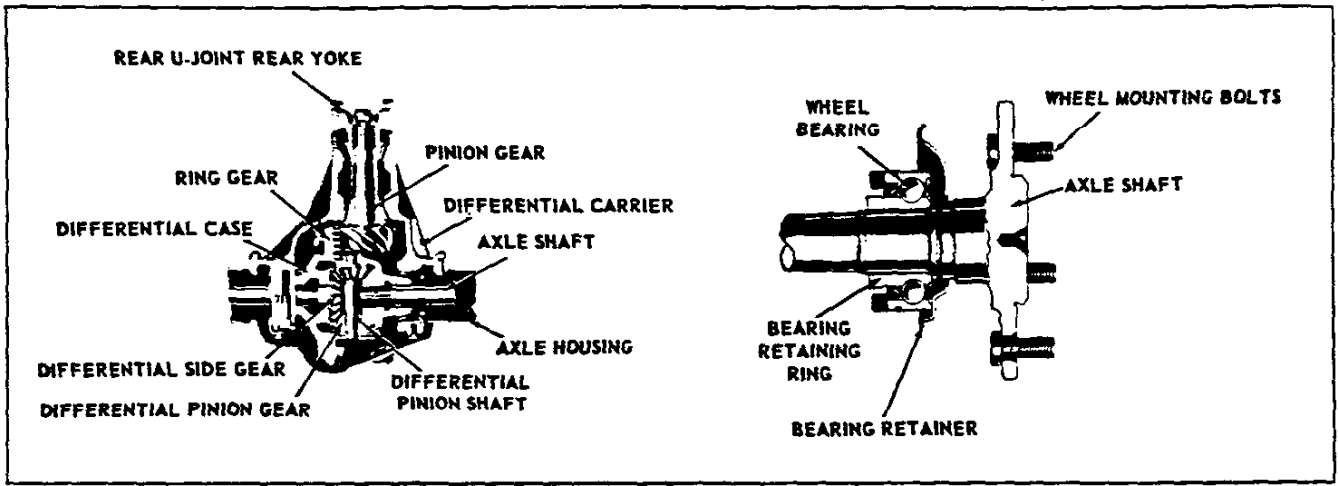

REAR AXLE

GENERAL

Make ----- Own
 Type ----- Semi-floating
 Rating ----- 3000 lb.
 Four Link Suspension Drive:
 Drive and torque taken through --- All control arms
 Lateral forces taken through --- Lateral control bar
 Housing Type ----- Pressed steel banjo, two
 piece welded construction with axle housing cover
 welded in place.
 Lubricant Capacity ----- 4 pints
 Lubricant Recommended ----- SAE 90 passenger
 car hypoid lubricant or "Multi-Purpose" lubricant.

AXLE SHAFT

Type and Material ----- Forged and hardened steel
 with wheel drive flange forged integral with shaft.
 Minimum Diameter ----- 1.06
 Oil Seal ----- Steel encased spring loaded
 synthetic rubber (part of rear wheel bearing assy.)
 Hub Attachment ----- Bolted to
 integrally forged wheel drive flange.

DIFFERENTIAL

Type ----- Two pinion with cast arms-steel housing
 Bearing cap bolt torque ----- 70-75 lb. ft.

		3-Speed			4-Speed		Overdrive	
		235-6	283-V8	348-V8	283-V8†	348-V8	235-6	283-V8
Axle ratio‡		3.55:1		3.55§	3.36	3.55:1		3.70:1
Overdrive lock position							Out	In
Total gear reduction*	First	10.44	8.77	8.30	7.81	10.88	7.61	
	Second	5.96	5.43	5.14	5.89	6.22	4.35	
	Third	3.55	3.55	3.36	4.65	3.70	2.59	
	Fourth				3.55			
	Reverse	10.44	9.94	9.41	7.99	10.88		
Max axle shaft torque in low gear (lb ft) ¶	235 6-cyl	1748				1822	1274	
	283 V8 2-bbl		1826			2266	1585	
	283 V8 4-bbl		1901			2358	1649	
	283 V8 FI		2087		1859			
	283 V8 FI (spec cam)		1975		1759			
	348 V8 4-bbl			2385	2258	2124		
	348 V8 4-bbl (spec cam)			NA	NA	NA		
	348 V8 3X2 bbl			2385	2258	2124		
348 V8 3X2-bbl (spec cam)			NA	NA	NA			

* - Axle ratio x transmission ratio.
 • - Gear reduction x maximum net engine torque x efficiency factor (.90 in direct drive, .85 all others).
 † - 4-speed transmission available on 283-V8 only when equipped with fuel injection.
 ‡ - 3.55 ratio with special cam engines only.

REAR AXLE - Continued

GEARS, FINAL DRIVE

Engine & Transmission	Type	Ratio	No. teeth ring gear & pinion
6 cyl & 283-V8 3-speed	Hypoid	3.55:1	9-32
348-V8 3-speed		3.36:1	11-37
6 cyl & 283-V8 O'drive		3.70:1	9-37
283-V8 4-speed		3.55:1	9-32
348-V8 4-speed		3.36:1	11-37
6 cyl & 283-V8 Pwrgld		3.36:1	11-37
283-V8 Turboglide		3.36:1	11-37
348-V8 Pwrgld & Tbogld		3.08:1	12-37

POWERGLIDE

Total Torque Multiplication (Final Drive Gears, Torque Converter and Planetary Gears):

Drive:

6-cylinder & 283 cu. in. V8 --- 12.84:1 to 3.36:1
 348 cu. in. V8 ----- 11.77:1 to 3.08:1

Low or reverse:

6-cylinder & 283 cu. in. V8 -- 12.84:1 to 6.12:1
 348 cu. in. V8 ----- 11.77:1 to 5.61:1

TURBOGLIDE

Total Torque Multiplication (Final Drive Gears, Torque Converter and Planetary Gears):

Drive:

283 cu. in. V8 ----- 14.45:1 to 3.36:1
 348 cu. in. V8 ----- 13.24:1 to 3.08:1

Reverse:

283 cu. in. V8 ----- 10.4
 348 cu. in. V8 ----- 9.5

Pinion Gear:

Mounting ----- Overhung
 Thrust taken by ----- Pinion bearings
 Adjustment --- By shims of .028 average thickness

POSITRACTION REAR AXLE

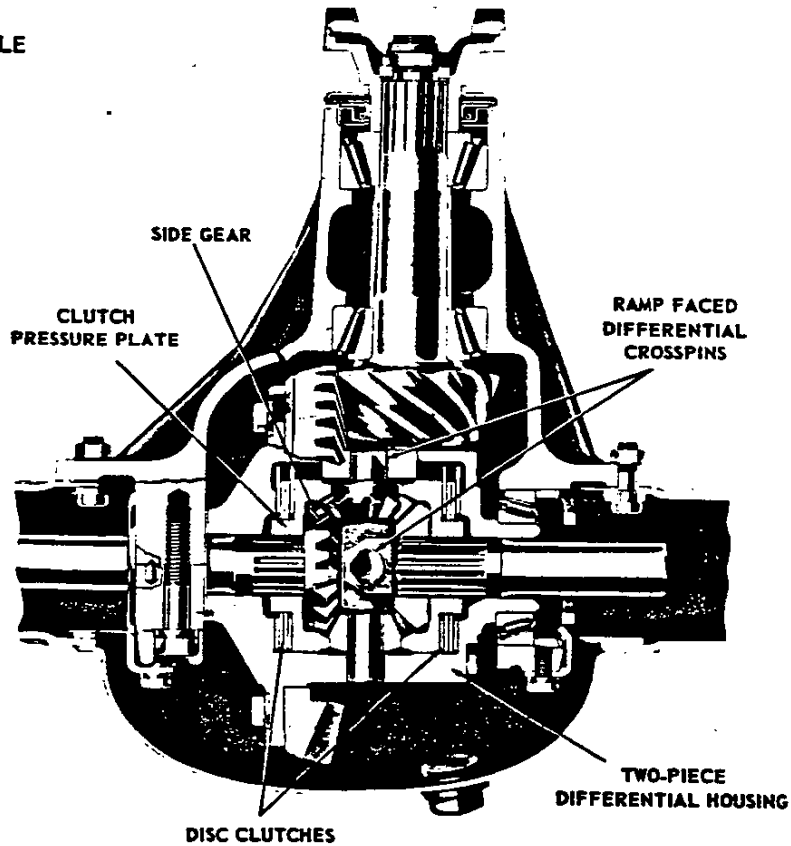

POSITRACTION

Make and Type ----- Spicer, limited slip, with dual multiple disc clutches applied by reaction to drive line torque through the differential side gears.

Clutch Driving Plate No. and Mat. ----- 4, CR steel
 Clutch Driven Plate No. and Mat. ----- 4, CR steel
 Number of Pinions ----- 4
 Active faces ----- 3

10-15-58
 8- CHASSIS

1959 CHEVROLET PASSENGER CAR

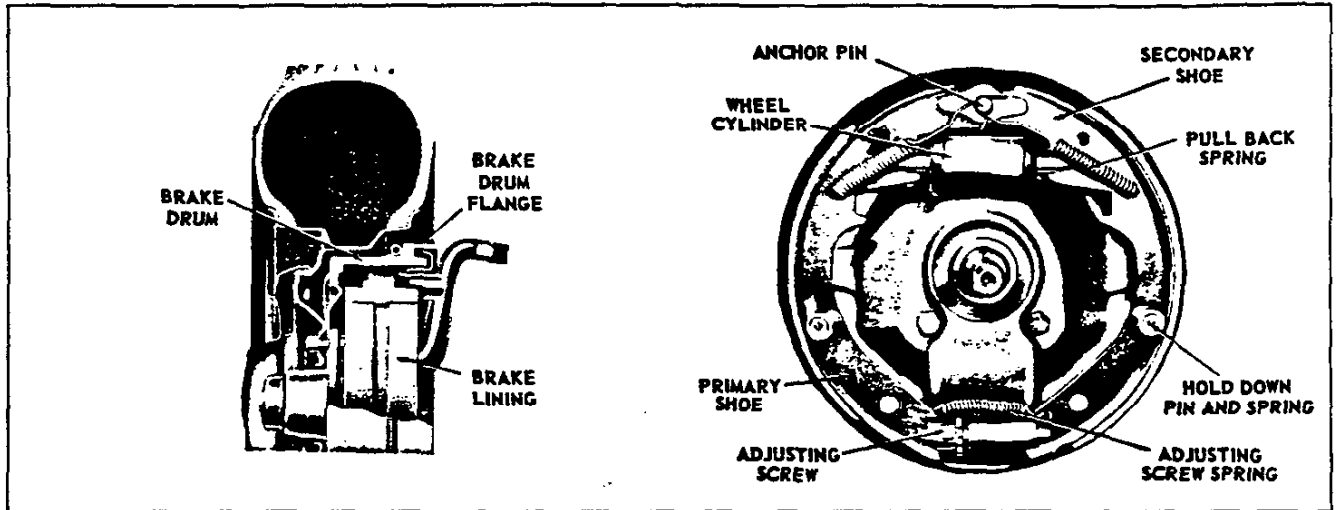

BRAKES

SERVICE BRAKES

Make ----- Own
 Type ----- Servo, four wheel hydraulic
 Brake Drum:
 Type ----- Composite
 Rim material ----- Cast alloy iron
 Web material ----- Pressed steel
 Diameter, front and rear ----- 11
 Total effective area ----- 328 sq. in.
 Distribution of Braking Effort (theoretical):
 On front wheels ----- 56%
 On rear wheels ----- 44%
 Brake Lining (dimensions after grinding):
 Material ----- Full molded asbestos composition
 Width, front brakes ----- 2.75
 Width, rear brakes ----- 2.00
 Thickness ----- .175
 Length per wheel ----- 21.00
 Length, primary shoe ----- 9.30
 Length, secondary shoe ----- 11.70
 Method of attachment to shoe ----- Bonded
 Clearance ----- Adjust to a
 light drag and back off seven notches.
 Total effective area ----- 185.6 sq.in.*
 Master Cylinder:
 Mounting ----- Under hood on dash panel
 Diameter ----- 1.0
 Piston travel ----- 1.329
 Wheel Cylinders:
 Piston travel ----- 0.221
 Mounting ----- Front, on wheel spindles,
 rear, on backing plate.
 Front, inside diameter ----- 1.125
 Rear, inside diameter ----- 1.00
 Braking Ratio:
 Pedal ----- 6.15:1
 Hydraulic ----- 4.53:1
 Total overall ----- 27.9:1

* - Gross lining area is 199.5 square inches.
 All primaries have .38 inch full length groove.

Foot Pedal:

Type ----- Pendant
 Travel ----- 6.38
 Mounting ----- On brace under dash
 Pad cover material ----- Rubber
 Brake system fluid capacity --- 0.70 pint (approx.)
 Brake fluid recommended ----- Delco Super 11

PARKING BRAKE

Make and Type ----- Own, mechanical pull rods
 and cables operate the two rear service brakes.
 Total Effective Lining Area ----- 77 sq. in.
 Control ----- Applied by pendulum foot pedal;
 released by upward pressure on integral lever sus-
 pended at left cowl side kick panel.

POWER BRAKES (RPO 412)

Type ----- Regular production
 master cylinder assisted by vacuum power unit.
 Power Unit Location ----- Mounted
 on dash under hood.

Braking Assistance (percentage):

By vacuum cylinder ----- 40%
 By foot pedal ----- 60%

Braking Ratio:

Pedal ----- 3.43:1
 Hydraulic ----- 4.53:1
 Overall ----- 15.5:1
 Pedal Load to Actuate Power Brakes ----- 10 lb.

STOP LIGHT SWITCH (Reg. prod. & RPO 412)

Type ----- Mechanical
 Mounting ----- Under dash

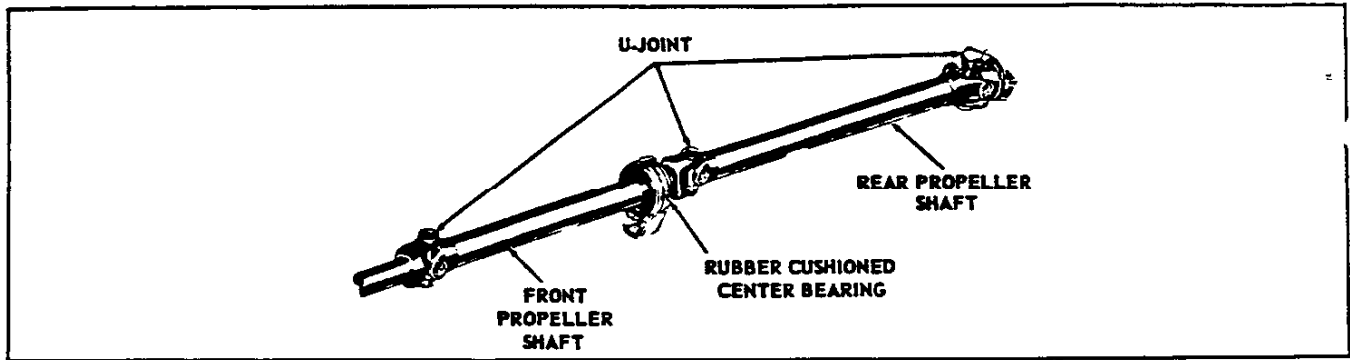

DRIVELINES

SPLINES

Clutch Disc to Trans. Clutch Gear Shaft -----
 ----- 10 straight side
 Trans. Mainshaft to Fr. U-joint Fr. Yoke -----
 ----- 16 involute
 Fr. Prop. Shaft to Intermediate U-joint Fr. Yoke ---
 ----- 9 straight side ϕ
 Rear U-joint R. Yoke to R. Axle Pinion Shaft -----
 ----- 17 involute
 Diff. Side Gears to R. Axle Shafts ----- 17 involute

Tube Wall Thickness ----- .092-.097
 Oil Seal ----- Steel reinforced, spring loaded leather
 End Types:
 Front shaft, fr.; rear shaft fr. & rr.--Welded yoke
 Front shaft, rear ----- Slip yoke

PROPELLER SHAFTS

Make ----- Own
 Number and Type ----- Two, tubular
 Tube Outside Diameter ----- 1.995-2.003

UNIVERSAL JOINTS

Make ----- Own
 Number ----- Three
 Type ----- Yoke and spider (trunnion)
 Trunnion Material ----- Drop forged steel, hardened

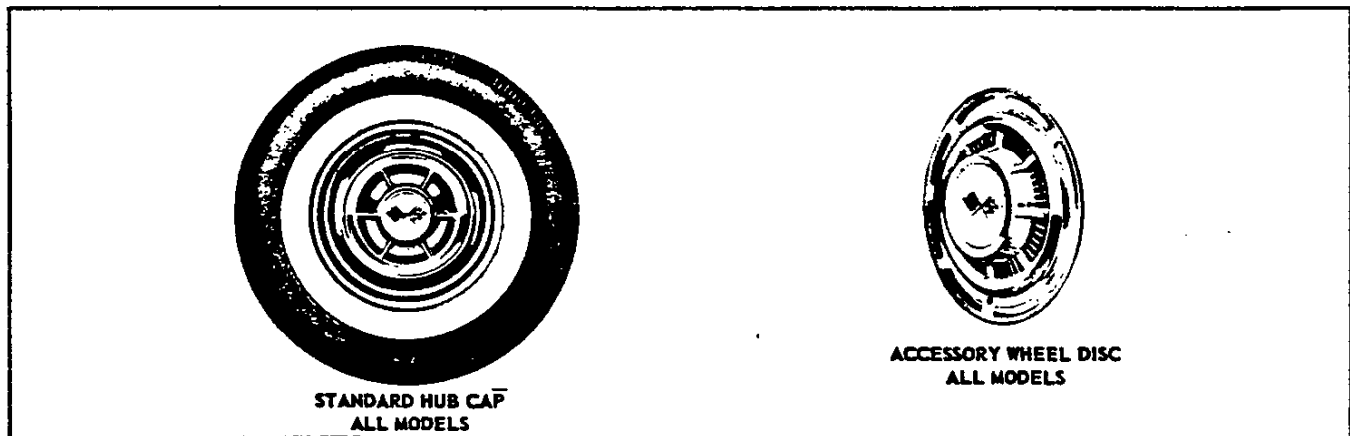

WHEELS AND TIRES

WHEELS

Make and Type ----- Own, short spoke disc.
 Attachment to hub ----- 5 hex. nuts, 7/16-20
 Bolt circle diameter ----- 4.75
 Offset and rim size ----- .560 x 14 x 5J (modified)
 (14 x 5-1/2 J on 9-pass. wagon)

TUBELESS TIRE DATA

Tire size and rating	Loaded rolling radius	Loaded rev's per mile	Loaded cap. each tire	Pressure	
				Fr.	Rr.
7.50-14-4	12.78	789	1085	24	24
8.00-14-4	13.01	774	1175	24	24 \$
8.50-14-4	13.30	760	1265	24	24
6.70-15-4#	13.31	760	1065	24	24

TIRES

Type ----- Tubeless, blackwall
 Size and Ply Rating:
 Convertible ----- Sedan Delivery, Sedan Pickup and
 Station Wagons ----- 8.00-14-4 *
 Balance of line ----- 7.50-14 -4

- RPO 330 Taxi Equipment only.
 * - 8.50-14-4 optional on Sedan Delivery and Sedan Pickup

ϕ - On 16 spline spacing; one spline extra width.
 10-15-58 • Revised 3-23-59

\$ - Rear pressure on 9-pass wagon 28 lb.

10-CHASSIS

1959 CHEVROLET PASSENGER CAR

ELECTRICAL COMPONENTS

HEADLIGHTS

Make ----- Guide, T-3
Type ----- Dual, horizontal
Sealed Beam Unit Diameter ----- 5.75
Dimmed By ----- Foot switch
High Beam Indicator ----- Chevrolet emblem
in speedometer face
Watts ----- 37.5-50
Volts ----- 12-16
Location ----- Outer extremity
of radiator grille

PARKING LIGHTS

Location ----- Outer extremity
of elongated air inlet
Bulb Replacement ----- Remove screws in bezel
Controlled By ----- Main switch

TAIL AND STOP LIGHTS

Make ----- Guide Lamp
Type ----- Two single tail lights having two
lamps, which serve as tail, stop and turn signals.

DIRECTIONAL SIGNAL

Make ----- Guide Lamp
Type ----- Flasher, front and rear,
self cancelling
Front ----- Uses double filament
parking bulb
Rear ----- Uses double filament
parking lamp bulb
Turn Indicators on Dash ----- Circles at
lower outer sides of speedometer face

BACK-UP LIGHTS

Location ----- Mounted at either extremity
of sheet metal below the bumper.
Impala Series and Nomad Station Wagon -----
Regular production
All Others ----- Optional

INSTRUMENT PANEL LIGHTING

Temperature Gauge ----- Clear white light
Gasoline Gauge ----- Clear white light
Speedometer Dial ----- Clear white light
High Beam Indicator ----- Red when lighted
Oil Pressure Indicator ----- The word "OIL"
(black letters on red background) visible when oil
pressure is below safety level.

Generator ----- The word "GEN"
(black letters on red background) visible when gen-
erator is not charging.

Turn Indicators ----- Green when lighted
Heater and Radio Controls ----- Reflected
green light

Glove Compartment ----- Clear white
light when switch is actuated by opening compart-
ment door.

MAIN SWITCH

Type ----- Three position "pull" type switch
mounted on instrument panel with protective fuse.
A rheostat operated by rotating the switch knob con-
trols the brightness of the instrument panel lights.
Passenger compartment lights are controlled by a
detent in the rheostat when switch knob is rotated to
extreme travel counter clockwise.

PASSENGER COMPARTMENT LIGHTS

Impala Sport Coupe and Sport Sedan ----- Dual
roof rail lamps
Convertible ----- Dual courtesy lamps,
one under instrument panel each side.
Station Wagon (9-Passenger) ----- Single courtesy
lamp on left side to rear of third seat.
Station Wagons ----- Single dome light
located approximately at center of roof. In addition
to switches listed below, a manual switch is provided
at light.
Manually Controlled By ----- Main switch
Automatically Controlled By ----- Opening
front doors only on 15-16-17-1800 Series. No auto-
matic control on 11-1200 Series.

REAR LICENSE LIGHTS

Station Wagons ----- One bulb under
emblem at top of license plate
All Others ----- Two bulbs in upper side
of recess for license plate.

HORNS

Make ----- Delco-Remy
Type ----- Vibrator
Number and Location ----- Two,
attached to radiator side support
Relay in Circuit ----- Yes
Current
High and low notes ----- 8-11 amperes

ELECTRICAL COMPONENTS - Continued

BULBS

Location			Quan.	Trade No.	CP¢	Location		Quan.	Trade No.	CP¢				
Headlamp	Outer	High beam	2	4002	37.5 W	Clock		1						
		Low beam			50W						Direction Signal Indicator	2	57	2
Headlamp	Inner	High beam	2	4001	37.5 W	Generator Indicator	1	90	6					
		Ash Tray Lamp	1	53	1	Glove Compartment Light	1							
Cigarette Lighter Lamp	1	Instrument Cluster	4 or 5											
Compass	1	Oil Pressure Indicator	1											
Headlamp Beam Indicator	1	Parking Brake Alarm	1											
Heater Lamp or Air Cond.	1	Side or Hardtops	2			1004	15							
Ignition Lock Light	1	Dome Lamps Others	1											
Courtesy Lamp	Convnt.	2	89			6	License Plate Lamp			1 or 2	67	3		
	Sta. Wgn. *	1	1073			32	Luggage Compartment Lamp			1	1003	15		
Back-up Lamp	2	Underhood Lamp					1			93	15			
Directional Signal-Frt.	Parking & turn	2	1034			4-32	Spot Lamp	Inside operated	1	4405	30W			
				Outside operated	1			4404						
Directional Signal-Rear	Tail, stop & turn	4				Portable	1	4416						
						Radio Dial	1	1891	1					

FUSES AND CIRCUIT BREAKERS

Device or Circuit Protected	Fuse & Amp	Circuit Breaker	Location
Air Conditioning (incl. heater)	SAE 20		Fuse block
Overdrive Solenoid			Eng. compt.
Underhood Lamp	SAE 9		Dash panel
Cigarette Lighter Lamp	AGC 3		Fuse block
Clock Lamp			
Compass Lamp			
Ignition Light			
Instrument Lamps			
Radio Lamp			
Tell-Tale Lamps			
Back Up Lamp			
Clock Motor			
Heater & Defroster (deluxe)		AGC 10	
Heater & Defroster (recirculating)			
Parking Brake Alarm	AGC 15		Fuse block
Dome lamp			
Glove Compartment Lamp			
License Lamp			
Luggage Compartment Lamp			
Stop Lamps			
Tail Lamps	Flasher		Fuse block
Directional Signal Indicator			
Hydraulic Folding Top Motor			
Headlamps		15 amp	Switch
Parking Lamps			
Power Seats		40 amp	Dr. pillar
Power Windows			
Windshield Wiper Motor		10 amp	Switch
Radio Receiver	Manual & pushbutton	AGC 4	Fuse block
	Signal seeking	AGC 7.5	
Spot Lamp	Inside operated	AGC 15	Fuse block
	Outside operated		

*9 - Passenger only

¢ - Candlepower

10-15-58

12-CHASSIS

1959 CHEVROLET PASSENGER CAR

BODY AND SHEET METAL

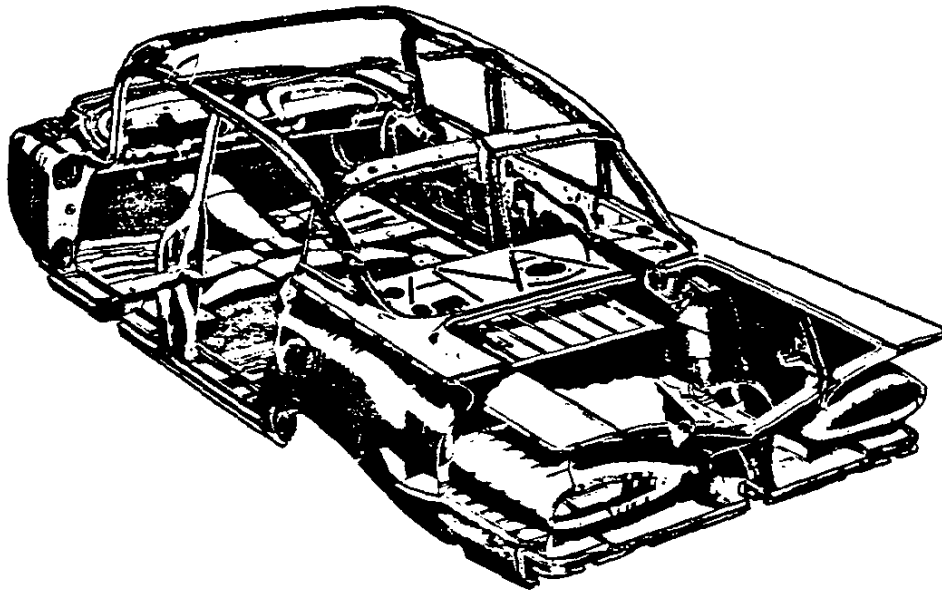

INTERIOR DIMENSIONS	2
EXTERIOR DIMENSIONS	6
EXTERIOR PAINT	8
EXTERIOR - INTERIOR COLOR COMBINATIONS	9
INTERIOR TRIM DISTRIBUTION	13
BODY GLASS	17
SEAT PADDING CHART	18

INTERIOR DIMENSIONS

NOTE: ALL DIMENSIONS SHOWN WITH A LETTER "c" SUFFIX ARE CHEVROLET DIMENSIONS.
ALL OTHERS ARE STANDARD GM DIMENSIONS.
ONLY 8 CYLINDER MODELS ARE SHOWN. (6 CYLINDER MODELS ARE IDENTICAL)

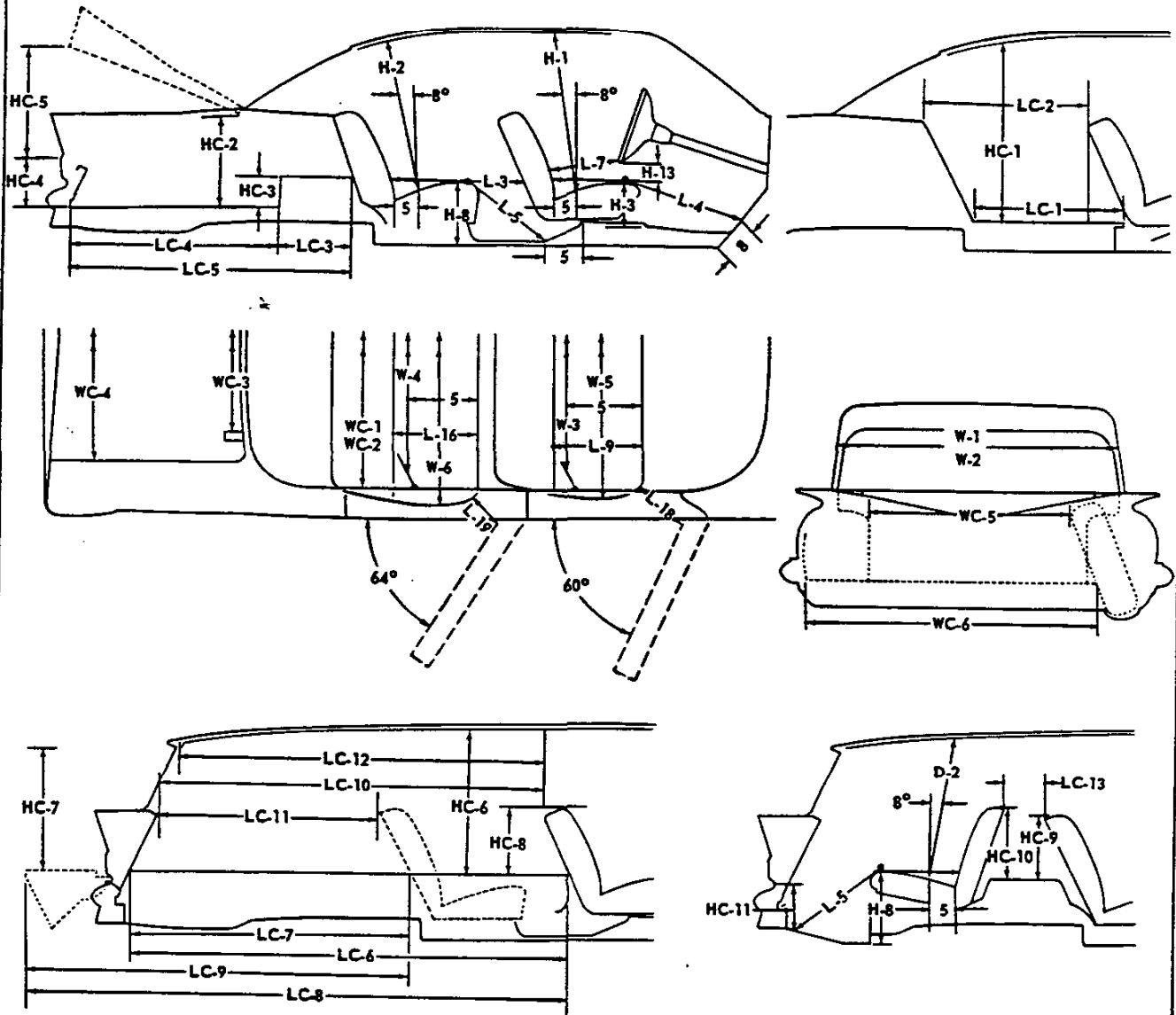

TRUNK AND CARGO CAPACITIES (CU. FT.)

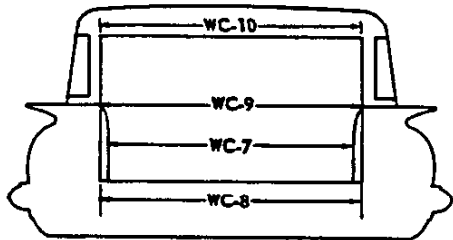

Models		Overall	Standard Luggage
Sedans and Sport Sedan		30.0	19.2
Sport Coupe		32.0	20.1
Convertible	Top up	29.5	19.3
	Top down	28.0	18.9
Station Wagons	6-pass.	Rear seat folded	92.0
		Rear seat erect	52.0
	9-pass.	Rear and third seat folded	90.0
		Rear erect and third folded	50.0
Utility Sedan	Inside load space (below window sills)	6.0	---
		31.0	---

10-15-58
2- BODY AND SHEET METAL

1959 CHEVROLET PASSENGER CAR

INTERIOR DIMENSIONS

INTERIOR LENGTHS		MODELS						
		1211 1221 1611	1219 1619 1819	1837	1639 1839	1867	1215	1235 1635 1645 1835
Dim.	Description							
L-3	Rear compartment room	29.2		25.7	29.5	25.5		29.3
L-4	Leg room - front	45.0			44.7			44.8
L-5	Leg room	42.8		37.6	40.8	37.6		41.7
	rear							
	third							38.3¢
L-7	Steering wheel clearance to seat back				14.2			
L-9	Seat depth - front			19.0				18.3
	rear	18.3		17.2	18.2	17.2		18.6
	third							18.0¢
L-16	Seat depth							
L-18	Entrance - foot clearance - front				15.4			
L-19	Entrance - foot clearance - rear		10.9		11.2			13.2
Lc-1	Rear compartment length at floor	35.1*						
Lc-2	Rear compartment length at belt	36.2*						
Lc-3	Trunk length - front	18.5		23.2	18.5	24.0		
Lc-4	Trunk length - rear			40.0				
Lc-5	Trunk length - overall	58.5	63.2	58.5	64.0			
Lc-6	Load length - G floor - front seat to tailgate - closed							94.8
Lc-7	Load length - G floor - rear seat to tailgate - closed							60.0
Lc-8	Load length - G floor - front seat to tailgate - open							120.1
Lc-9	Load length - G floor - rear seat to tailgate - open							85.3
Lc-10	Load length at belt - front seat to tailgate - closed							84.2
Lc-11	Load length at belt - rear seat to tailgate - closed							48.2
Lc-12	Load length at roof - front seat to back window							78.1
Lc-13	Clearance - rear seat to third seat							9.0¢
INTERIOR WIDTHS								
W-1	Hat room - front	57.3			57.5			57.4
	rear	56.8		55.5	57.3	52.8		57.2
	third							54.4¢
W-3	Shoulder room - front				60.5			
	rear	59.7		58.8	51.3			59.2
	third							57.5¢
W-5	Hip room - front	66.1			66.3			66.1
	rear	65.5		57.0	66.2	52.7		66.0
	third							46.5¢
Wc-1	Rear compartment width at floor	67.6*						
Wc-2	Rear compartment width at belt	60.2*						
Wc-3	Width between trunk hinge boxes			39.5				
Wc-4	Trunk maximum opening width			52.0				
Wc-5	Spare tire to opposite wheel housing			43.1				
Wc-6	Trunk maximum width at floor			61.0				
Wc-7	Minimum width between wheel houses			46.0				46.4
Wc-8	Tailgate opening width at floor							47.6
Wc-9	Tailgate opening width at belt							46.0
Wc-10	Rear window opening width							44.6
INTERIOR HEIGHTS								
H-1	Head room - front	36.1		33.3	33.7	34.0		35.8
	rear	34.3		34.2	34.5	34.3		36.9
	third							34.0¢
H-3	Chair height - front			9.2				9.3
	rear	13.8		12.0	11.5	12.0		12.2
	third							16.0¢
H-11	Entrance room - front	29.3		28.8	28.6	28.4		29.2
H-12	Entrance room - rear		28.0		29.0			29.5
H-13	Steering wheel clearance				5.2			
Hc-1	Rear compartment - maximum height	37.4*						
Hc-2	Trunk maximum height			20.0				
Hc-3	Trunk floor kickup height			7.4				
Hc-4	Trunk sill to floor			12.5				
Hc-5	Trunk maximum opening height	33.6		35.4	33.6			
Hc-6	Load height - maximum							32.1
Hc-7	Rear opening height							26.7
Hc-8	Front seat back to load floor							13.6
Hc-9	Rear seat back to load floor							13.7
Hc-10	Third seat back to load floor							15.8¢
Hc-11	Sill height third seat							13.0¢

* - Model 1221 utility sedan only. † - Model 1645 9 passenger station wagon only.

• Revised 3-23-59 10-15-51
BODY AND SHEET METAL-

INTERIOR DIMENSIONS AND PLATFORM HEIGHTS

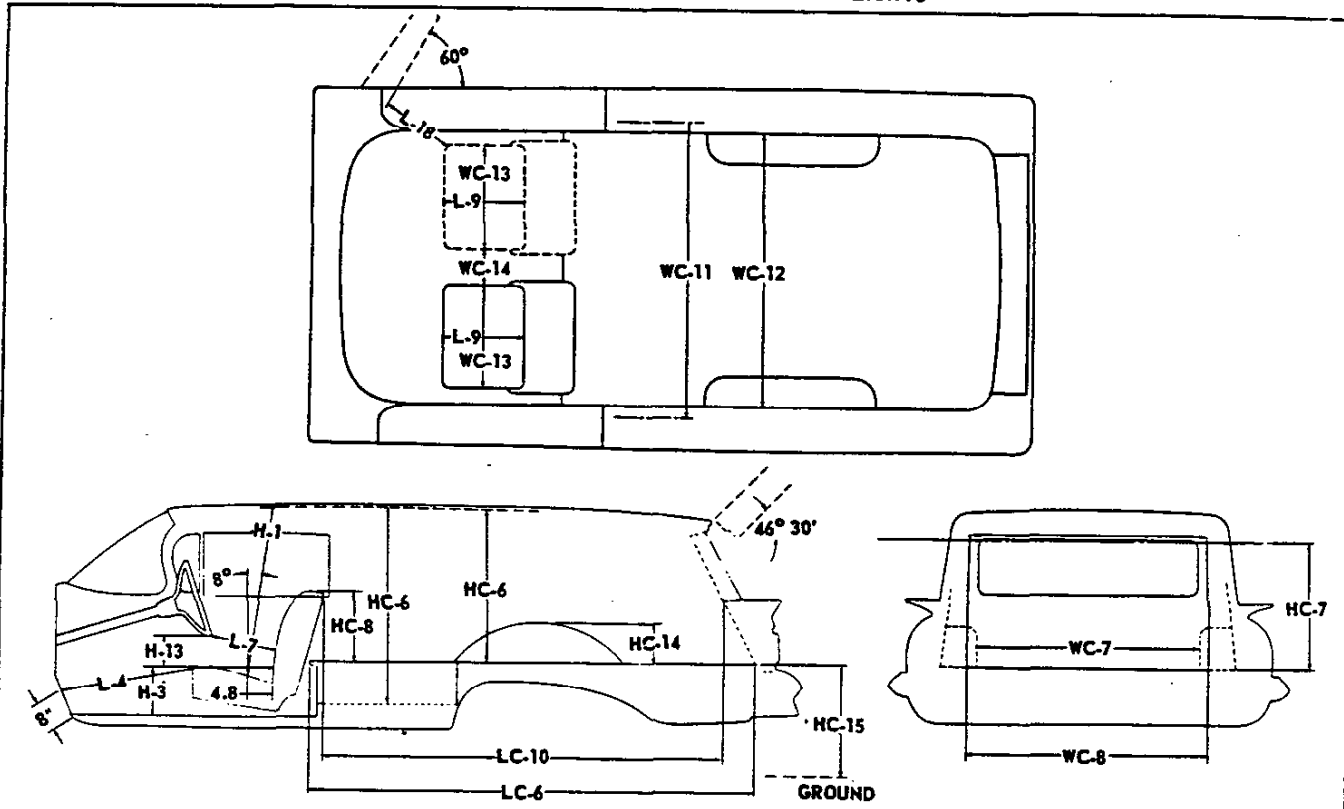

INTERIOR LENGTHS		MODEL	
Dim.	Description	1270	
L-4	Legroom	45.1	
L-7	Steering wheel clearance to seat back	14.6	
L-9	Seat depth	17.1	
L-18	Entrance-foot clearance	16.7	
Lc-6	Load length-front seat to lift gate closed	93.8	
Lc-10	Load length at belt	84.2	
INTERIOR WIDTHS			
Wc-7	Minimum width between wheelhouses	46.5	
Wc-8	Liftgate opening at floor	47.6	
Wc-11	Load width at floor	64.3	
Wc-12	Load width at belt	60.7	
Wc-13	Seat width	20.3	
Wc-14	Seat clearance	6.0	
INTERIOR HEIGHTS			
H-1	Headroom	35.7	
H-3	Chair height	9.1	
H-13	Steering wheel clearance	5.2	
Hc-6	Load height-maximum	Flush floor	32.2
		Depressed floor	40.2
Hc-7	Rear opening height	25.9	
Hc-8	Front seat back to load floor	14.6	
Hc-14	Wheelhouse height	10.7	
Hc-15	Platform Height	@ design with 8.00-14-4 tires	25.8
		@ design with 8.50-14-4 tires	26.1
		@ curb with 8.00-14-4 tires	27.0
		@ curb with 8.50-14-4 tires	27.3

10-15-58

4-BODY AND SHEET METAL

1959 CHEVROLET PASSENGER CAR

INTERIOR DIMENSIONS AND PLATFORM HEIGHTS

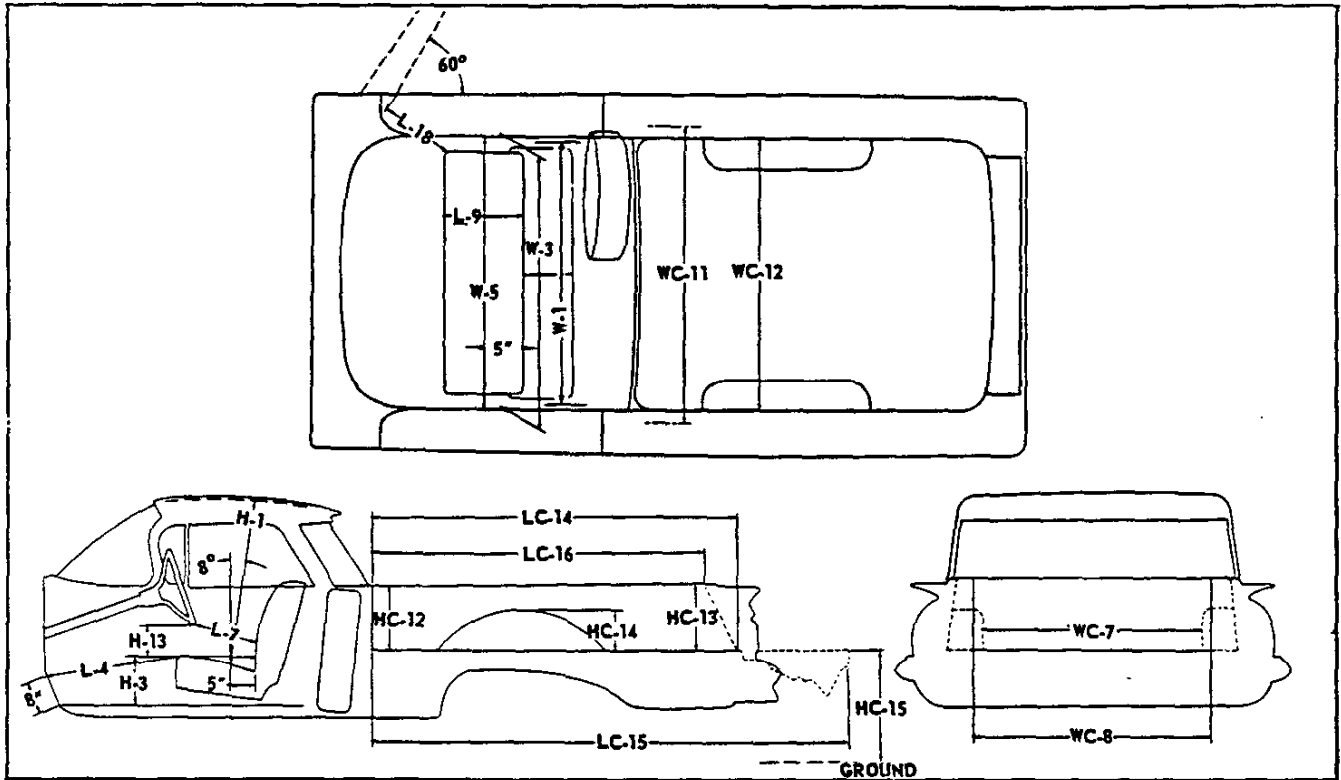

INTERIOR LENGTHS		MODEL
Dim.	Description	1280
L-4	Leg room	45.0
L-7	Steering wheel clearance to seat back	14.2
L-9	Seat depth	19.0
L-18	Entrance - foot clearance	15.4
Lc-14	Box length at floor - tailgate closed	76.2
Lc-15	Box length at floor - tailgate open	96.8
Lc-16	Box length at belt	70.6
INTERIOR WIDTHS		
W-1	Hat room	57.3
W-3	Shoulder room	60.5
W-5	Hip room	66.1
Wc-7	Minimum width between wheelhouses	46.5
Wc-8	Tailgate opening at floor	47.6
Wc-11	Box width at floor	64.3
Wc-12	Box width at belt	60.7
INTERIOR HEIGHTS		
H-1	Headroom	36.1
H-3	Chair height	9.2
H-13	Steering wheel clearance	5.2
Hc-12	Box height - front	12.8
Hc-13	Box height - rear	13.3
Hc-14	Wheelhouse height	10.7
Hc-15	Platform Height	@ Design with 8.00-14-4 tires
		@ Design with 8.50-14-4 tires
		@ Curb with 8.00-14-4 tires
		@ Curb with 8.50-14-4 tires

EXTERIOR DIMENSIONS

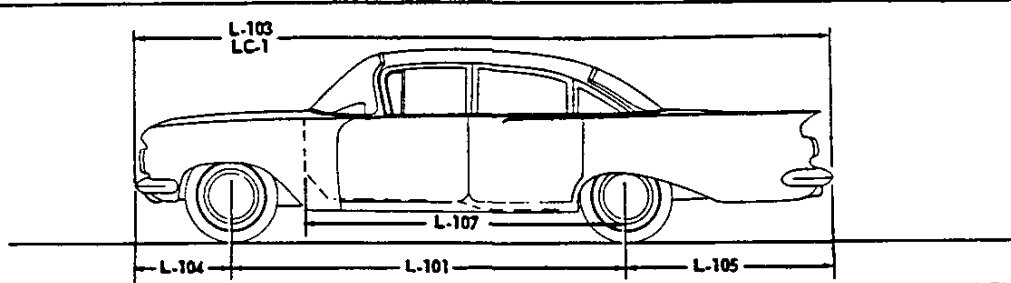

EXTERIOR LENGTHS		MODELS								
		1211	1219	1837	1639	1867	1215	1235	1270	1280
Dim.	Description	1221	1619		1839			1635		
		1611	1819				1645			
							1835			
L-101	Wheelbase	119.0								
L-103	Overall length-bumper to bumper	210.9								
L-104	Overhang - front	32.6								
L-105	Overhang - rear	59.3								
L-107	Front of dash to $\frac{1}{2}$ of rear wheels	100.6								
Lc-1	Overall length less bumpers	195.2								

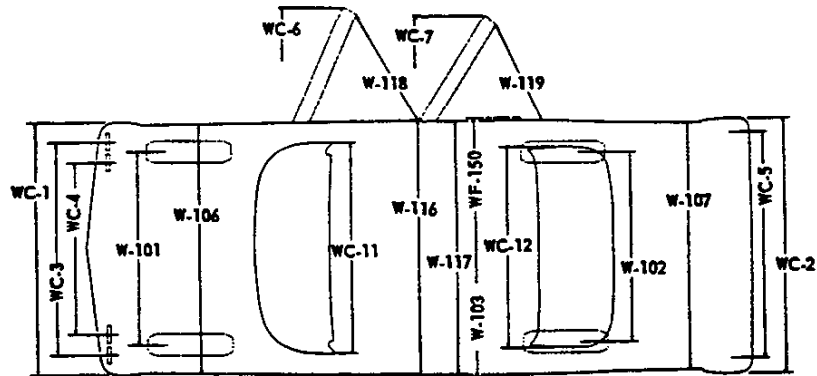

EXTERIOR WIDTHS		MODELS								
		1211	1219	1837	1639	1867	1215	1235	1270	1280
Dim.	Description	1221	1619		1839			1635		
		1611	1819				1645			
							1835			
W-101	Tread-front	60.3								
W-102	Tread-rear	59.3								
W-103	Overall width (maximum)	79.9								
W-106	Front fender width at $\frac{1}{2}$ of wheel	78.9								
W-107	Rear fender width at $\frac{1}{2}$ of wheel	78.4								
W-116	Maximum overall width of body	78.5								
W-117	Maximum body width at center pillar	79.1								
W-118	Door swing out distance - front	45.2	35.8	35.8	35.8	35.8	45.2	35.8	45.2	45.2
W-119	Door swing out distance - rear		28.9		28.9			28.9		
Wf-150	Maximum overall width with moldings	79.7								
Wc-1	Front bumper width	79.9								
Wc-2	Rear bumper width	79.9								
Wc-3	Outer headlight centers width	70.0								
Wc-4	Inner headlight centers width	57.4								
Wc-5	Tail light centers width	59.8								
Wc-6	Overall width, front doors open	161.2	145.9	161.2	145.9	161.2	161.2	145.9	161.2	161.2
Wc-7	Overall width, rear doors open		134.4		134.4			134.4		
Wc-8	Opening width at beltline - frt. door	32.4	23.4	32.4	23.4	32.4	32.4	23.4	32.4	32.4
Wc-9	Opening width below beltline - frt. door	46.2	34.9	46.2	34.9	46.2	46.2	34.9	46.2	46.2
Wc-10	Opening width below beltline - rr. door		28.1		28.1			28.1		
Wc-11	Windshield DLO width	64.6								
Wc-12	Rear window DLO width	61.2			45.4			47.0	62.5	

EXTERIOR DIMENSIONS

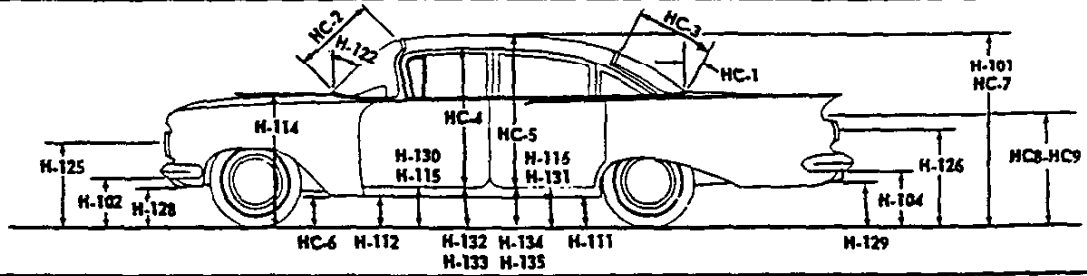

EXTERIOR HEIGHTS		MODELS										
		1211	1219	1837	1639	1867	1215	1235	1270	1280		
Dim.	Description	1221	1619		1839			1635				
		1611	1819				1645					
							1835					
H-101	Overall height - loaded	56.0		54.0		56.0		56.3		56.3		
H-102	Front bumper bottom to ground				10.9		11.2		11.9		11.4	
H-104	Rear bumper bottom to ground				11.4		11.7		12.4		13.6	
H-111	Bottom of body to ground				8.0						10.3	
H-112	Rocker panel to ground - front				8.5						10.8	
H-114	Hood at rear to ground						38.6					
H-115	Step height - front door - loaded				13.1						13.2	
H-116	Step height - rear door - loaded	12.8				12.8		12.8				
H-122	Windshield slope angle	48.8°				55.3°				48.8°		
H-125	Headlight centerline to ground						24.1					
H-126	Taillight centerline to ground						25.7					
H-128	Bottom of front bumper guard to ground						10.8					
H-129	Bottom of rear bumper guard to ground						11.4					
H-130	Step height - front door - unloaded	14.7				14.9		15.5		14.9		
H-131	Step height - rear door - unloaded	15.1		14.9				15.7				
H-132	Bottom of front door to ground - open				11.7				11.9		12.1	
H-133	Bottom of front door to ground - closed				10.6				10.8		10.6	
H-134	Bottom of rear door to ground - open	11.5				11.5				11.7		
H-135	Bottom of rear door to ground - closed	10.4		10.4				10.4				
Hc-1	Rear window slope angle	59°		62°		60°		59.8°		25°0'	47°	
Hc-2	Windshield DLO slant height						26.6					
Hc-3	Rear window DLO slant height	25.7		29.0		17.0		16.8		14.0	13.0	15.5
Hc-4	Front door opening height	37.6		36.5		36.3		35.9		37.7	37.6	37.6
Hc-5	Rear door opening height	37.3		36.2						37.3		
Hc-6	Bottom of front fender at rr. to ground						9.5					
Hc-7	Overall height - unloaded	58.1		56.1		58.1		58.4		58.4		
Hc-8	Trunk sill to ground-loaded				28.4							
Hc-9	Tailgate to ground-open-loaded								24.8			

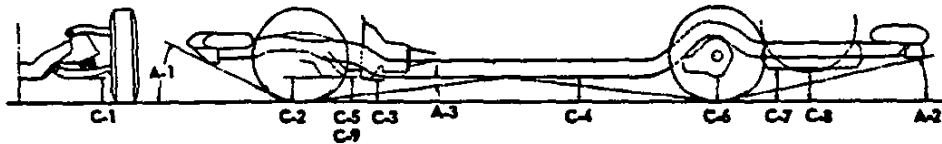

GROUND CLEARANCES		MODELS									
		1211	1219	1837	1639	1867	1215	1235	1270	1280	
Dim.	Description	1221	1619		1839			1635			
		1611	1819				1645				
							1835				
A-1	Angle of approach						25°45'				
A-2	Angle of departure						12°				
A-3	Ramp breakover angle						12.5°				
C-1	Front suspension to ground						6.9				
C-2	Oil pan to ground						6.6				
C-3	Flywheel housing to ground						6.5				
C-4	Frame to ground						6.4				
C-5	Exhaust system to ground				6.0				6.7		
C-6	Rear axle to ground						7.3				
C-7	Fuel tank to ground				7.8				12.3*		
C-8	Tire well to ground	8.3				8.4		8.2			
C-9	Minimum ground clearance				6.0†				6.7		

† At muffler
* 7.6 on 1645

EXTERIOR PAINT

TWO-TONE PAINT AREAS

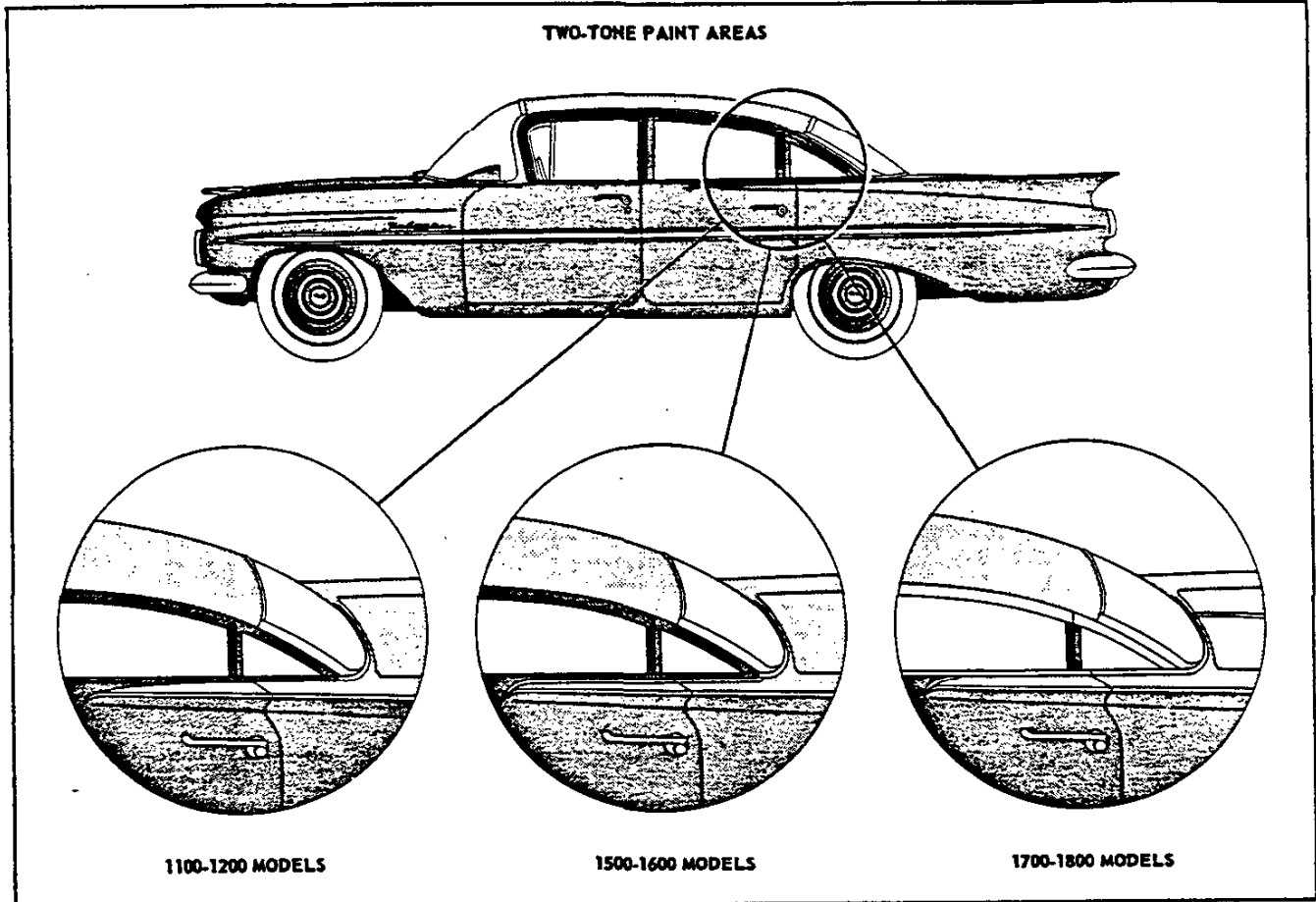

NINE STEP FINISHING PROCESS

1. **Rustproofing** . . . The bare steel is thoroughly treated with chemicals that clean the metal and give it a corrosion-resisting surface. This chemical treatment also etches the metal which improves paint adhesion.
2. **Sheet Metal Primer** . . . A primer coat is applied to all outside and inside surfaces of the front fenders and hood. This is done by dipping or flowcoating to insure coating in all seams and secluded areas, and then baking at 390°F for 30 minutes. After baking, a coat of sealer is applied to all surfaces requiring a subsequent coat of lacquer.
3. **Body Primer** . . . Specially formulated corrosion resistant primers are used for all areas of the body where rust could possibly develop. Areas considered especially critical are subsequently coated with another type rust inhibiting compound after the lacquer coats have been applied.
4. **Primer-Surfacer Coat** . . . A primer-surfacer coat is applied to all outside surfaces of the body requiring lacquer and then oven baked a minimum of 45 minutes at 285°F.
5. **Sanding** . . . Power wet-sanding followed by hand sanding is done on all surfaces requiring lacquer. After sanding, surface is inspected and additional spot sanding is done to assure an absolutely smooth surface as a base for the lacquer.
6. **Lacquering** . . . Many coats of lacquer are now sprayed on the surfaces to build up a finish of the required thickness for each color.
7. **Final Baking** . . . To assure a durable, hard, high luster finish the lacquer is now baked 30 minutes at 200°F.
8. **Undercoating** . . . An asphaltous based - asbestos fiber type sound deadener is sprayed inside the wheel housings and on the underside of the underbody at designated locations to block out road noises.
- 9a. **Polishing** . . . Machine buffing with special pastes to provide both a high luster and a glassy smooth surface.
- 9b. **Paint Repair** . . . Any slight mars, nicks, or scratches that might occur during final assembly are factory-repaired and corrected before shipping.

**EXTERIOR - INTERIOR COLOR COMBINATIONS
BISCAYNE SERIES, EL CAMINO, SEDAN DELIVERY, AND BROOKWOOD STATION WAGONS**

EXTERIOR			INTERIOR	
SOLID COLORS	TWO-TONE COLORS **		FABRICS	PAINT
	Roof & Upper Deck (or Tailgate)	Lower Body & Wheels		
Tuxedo Black †	Snowcrest White	Tuxedo Black	Light and Medium Gray	Medium Gray
Crown Sapphire	Snowcrest White	Crown Sapphire		
Gothic Gold †	Satin Beige	Gothic Gold		
Roman Red †	Snowcrest White	Roman Red		
Snowcrest White †	Snowcrest White	Grecian Gray		
Cameo Coral	Satin Beige	Cameo Coral		
Grecian Gray				
Satin Beige				
Highland Green †	Snowcrest White	Highland Green	Light and Medium Green *	Medium Green *
Aspen Green †	Aspen Green	Classic Cream		
Classic Cream				
Frost Blue †	Frost Blue	Harbor Blue	Light and Medium Blue *	Dark Blue *
Harbor Blue	Harbor Blue	Frost Blue		

* - Gray is substituted for models 11-1221, 11-1270

** - Two-Tone not available for models 11-1270

† - Only colors available on models 11-1270

**EXTERIOR - INTERIOR COLOR COMBINATIONS
BEL AIR SERIES; KINGSWOOD AND PARKWOOD STATION WAGONS**

EXTERIOR			INTERIOR	
SOLID COLORS	TWO-TONE COLORS		FABRICS	PAINT
	Roof & Upper Deck (or Tailgate)	Lower Body & Wheels		
Tuxedo Black	Snowcrest White	Tuxedo Black	Light and Medium Gray	Medium Gray
Roman Red	Snowcrest White	Roman Red		
Snowcrest White	Snowcrest White	Grecian Gray		
Cameo Coral	Satin Beige	Cameo Coral		
Grecian Gray				
Highland Green	Snowcrest White	Highland Green	Light and Medium Green	Medium Green
Aspen Green	Aspen Green	Classic Cream		
Classic Cream				
Frost Blue	Frost Blue	Harbor Blue	Light and Medium Blue	Dark Blue
Harbor Blue	Harbor Blue	Frost Blue		
Crown Sapphire	Snowcrest White	Crown Sapphire	Light and Medium Turquoise	Medium Turquoise
Gothic Gold	Satin Beige	Gothic Gold	Light and Medium Copper	Medium Copper
Satin Beige				

**EXTERIOR - INTERIOR COLOR COMBINATIONS
IMPALA SERIES AND NOMAD STATION WAGON**

EXTERIOR			INTERIOR	
SOLID COLORS	TWO-TONE COLORS *		FABRICS	PAINT
	Roof & Upper Deck (or Tailgate)	Lower Body & Wheels		
Tuxedo Black	Snowcrest White	Tuxedo Black	Light and Medium Gray	Medium Gray **
Roman Red	Snowcrest White	Roman Red		
Snowcrest White	Snowcrest White	Grecian Gray		
Cameo Coral	Satin Beige	Cameo Coral		
Grecian Gray				
Highland Green	Snowcrest White	Highland Green	Light and Medium Green	Medium Green **
Aspen Green	Aspen Green	Classic Cream		
Classic Cream				
Frost Blue	Frost Blue	Harbor Blue	Light and Medium Blue	Dark Blue **
Harbor Blue	Harbor Blue	Frost Blue		
Crown Sapphire	Snowcrest White	Crown Sapphire	Light and Medium Turquoise	Medium Turquoise **
Snowcrest White				
Gothic Gold	Satin Beige	Gothic Gold	Light and Medium Copper	Medium Copper **
Satin Beige				
Tuxedo Black	Snowcrest White	Tuxedo Black	Red ‡	Red ‡
Roman Red	Snowcrest White	Roman Red		
Snowcrest White	Snowcrest White	Grecian Gray		
Grecian Gray				

* - Not available for Convertible.

** - Upper and lower portions of steering wheel painted a light tone.

‡ - Not available for 4-Door Sedan or Nomad Station Wagon.

**EXTERIOR - INTERIOR COLOR COMBINATIONS
IMPALA SERIES AND NOMAD STATION WAGON**

EXTERIOR			INTERIOR	
SOLID COLORS	TWO-TONE COLORS *		FABRICS	PAINT
	Roof & Upper Deck (or Tailgate)	Lower Body & Wheels		
Tuxedo Black	Snowcrest White	Tuxedo Black	Light and Medium Gray	Medium Gray **
Roman Red	Snowcrest White	Roman Red		
Snowcrest White	Snowcrest White	Grecian Gray		
Cameo Coral	Satin Beige	Cameo Coral		
Grecian Gray				
Highland Green	Snowcrest White	Highland Green	Light and Medium Green	Medium Green **
Aspen Green	Aspen Green	Classic Cream		
Classic Cream				
Frost Blue	Frost Blue	Harbor Blue	Light and Medium Blue	Dark Blue **
Harbor Blue	Harbor Blue	Frost Blue		
Crown Sapphire	Snowcrest White	Crown Sapphire	Light and Medium Turquoise	Medium Turquoise **
Snowcrest White				
Gothic Gold	Satin Beige	Gothic Gold	Light and Medium Copper	Medium Copper **
Satin Beige				
Tuxedo Black	Snowcrest White	Tuxedo Black	Red †	Red †
Roman Red	Snowcrest White	Roman Red		
Snowcrest White	Snowcrest White	Grecian Gray		
Grecian Gray				

* - Not available for Convertible.

** - Upper and lower portions of steering wheel painted a light tone.

† - Not available for 4-Door Sedan or Nomad Station Wagon.

IMPALA CONVERTIBLE TOP COLORS

EXTERIOR COLOR	TOP COLOR			
	Ivory	Black	Green	Blue
Tuxedo Black	X	X		
Aspen Green	X	X	X	
Highland Green	X		X	
Crown Sapphire	X	X		
Frost Blue	X	X		X
Harbor Blue	X			X
Gothic Gold	X	X		
Roman Red	X	X		
Snowcrest White	X	X		
Grecian Gray	X	X		
Classic Cream	X	X	X	
Cameo Coral	X	X		
Satin Beige	X	X		

**INTERIOR TRIM DISTRIBUTION
BISCAYNE SEDANS & BROOKWOOD STATION WAGONS**

AREA		MATERIAL	INTERIOR TRIM COLOR TONE
Seats	Cushion and Backrest	Pattern Cloth*	Medium
	Cushion and Backrest Bolster	Leather Grain Vinyl	Light
	Cushion and Backrest Facing		
	Front Seat Back		
		Lower	Leather Grain Vinyl
Lower Cross Bar			
Pass. Area Side- walls	Upper Area and Dividing Welt	Leather Grain Vinyl	Light
	Lower Area and Scuff Pad	Leather Grain Vinyl	Medium
Sunshade		Embossed Board	Light
Sunshade Binding		Leather Grain Vinyl	
Headlining		Cloth*	
Cowl Side Kick Panel		Embossed Board	Medium
Floor Covering		Vinyl Covered Rubber	Medium**
Utility Area†	Upper Sidewall	Leather Grain Vinyl	Light
	Lower Sidewall	Embossed Board	Medium
	Rear Division Wall	Panel Board, Painted	
	Wheelhouse	Paint	
	Utility Floor Covering	Rubber	Black
Load Area‡	Sidewall	Leather Grain Vinyl	Medium
	Wheelhouse Cover Panel		
	Load Floor Covering	Vinyl Type Linoleum	

- * - Pattern Vinyl on Station Wagons
- ** - Medium color spattered over black
- † - Utility Sedan only
- ‡ - Station Wagons only

**INTERIOR TRIM DISTRIBUTION
BEL AIR SERIES, PARKWOOD AND KINGSWOOD STATION WAGONS**

AREA		MATERIAL	INTERIOR TRIM COLOR TONE	
Seats	Cushion and Backrest	Pattern Cloth*	Medium	
	Cushion and Backrest Bolster	Leather Grain Vinyl		
	Bolster Insert	Leather Grain Vinyl	Light	
	Cushion and Backrest Facing	Leather Grain Vinyl	Medium	
	Front Seat Back			Upper
				Lower
Lower Cross Bar				
Pass. Area Side-walls	Upper Area			
	Lower Area and Scuff Pad			
	Dividing Welt	Leather Grain Vinyl	Light	
Arm-rest	Upper Area	Leather Grain Vinyl	Medium	
	Base	Plastic		
Sunshade		Cloth**	Light	
Sunshade Binding		Leather Grain Vinyl		
Headlining		Cloth**		
Cowl Side Kick Panel		Embossed Board	Medium	
Floor Covering		Carpet‡		
Load Area\$	Sidewall	Leather Grain Vinyl		
	Wheelhouse Cover Panel			
	Load Floor Covering	Vinyl Type Linoeum		

* - Plastic backed pattern cloth on Station Wagons

** - Pattern vinyl on Station Wagons

‡ - With medium color rubber inserts, front and rear

\$ - Station-Wagons only

**INTERIOR TRIM DISTRIBUTION
IMPALA SERIES AND NOMAD STATION WAGON**

AREA		MATERIAL	INTERIOR TRIM COLOR TONE	
Seats	Cushion and Backrest	Pattern Cloth*	Medium	
	Backrest Bolster Insert	Leather Grain Vinyl		
	Dividing Welts	Vinyl	Bright	
	Cushion and Backrest Bolster	Leather Grain Vinyl	Light**	
	Cushion and Backrest Facing			
	Front Seat Back	Upper Area	Leather Grain Vinyl	Medium
		Lower Area	Leather Grain Vinyl	Light**
		Lower Cross Bar	Leather Grain Vinyl	Medium
Front Seat End Panels***		Aluminum	Bright	
Pass. Area Side- walls	Upper Area	Leather Grain Vinyl	Medium	
	Dividing Welts	Vinyl	Bright	
	Lower Area and Scuff Pad	Leather Grain Vinyl	Light**	
	Sidewall Insert	Leather Grain Vinyl	Medium	
Armrest		Leather Grain Vinyl†		
Sunshade		Pattern Vinyl‡‡	Light‡‡‡	
Sunshade Binding		Leather Grain Vinyl		
Headlining\$		Pattern Vinyl‡‡		
Cowl Side Kick Panel		Embossed Board	Medium	
Floor Covering		Carpet\$\$		
Load Area \$\$\$	Sidewall	Leather Grain Vinyl		
	Wheelhouse Cover Panel			
	Load Floor Covering	Vinyl Type Linoleum		

- * - Pattern vinyl on Convertible
- ** - Medium tone on red trim
- *** - Not used on 4-Door Sedan and Station Wagon
- † - Plastic base on 4-Door Sedan and Station Wagon
- ‡‡ - Cloth on 4-Door Sedan
- ‡‡‡ - Light gray on red trim
- \$ - Not used on Convertible
- \$\$ - Carpet texture vinyl covered rubber on Convertible
- \$\$\$ - Station Wagon only

**INTERIOR TRIM DISTRIBUTION
BISCAYNE SEDAN DELIVERY**

AREA		MATERIAL	INTERIOR TRIM COLOR TONE
Seats	Cushion and Backrest	Leather Grain Vinyl	Medium
	Cushion and Backrest Facing	Leather Grain Vinyl	Light
	Back of Backrest	Leather Grain Vinyl	Medium
Side-walls	Upper Area and Dividing Welt	Leather Grain Vinyl	Light
	Lower Area and Scuff Pad	Leather Grain Vinyl	Medium
Sunshade		Embossed Board	Light
Sunshade Binding		Leather Grain Vinyl	
Headlining		Pattern Vinyl	
Cowl Side Kick Panel		Embossed Board	Medium
Floor Covering (front)		Vinyl Covered Rubber*	
Load Area	Side Panels	Paint	
	Wheelhouses		
	Rear Door		
	Load Platform		







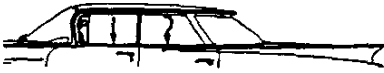

* - Medium color spattered over black

**INTERIOR TRIM DISTRIBUTION
EL CAMINO SEDAN PICKUP**

AREA		MATERIAL	INTERIOR TRIM COLOR TONE
Seats	Cushion and Backrest	Pattern Vinyl	Medium
	Cushion and Backrest Bolster	Leather Grain Vinyl	Light
	Cushion and Backrest Facing		
	Front Seat Back		
		Lower	Leather Grain Vinyl
Lower Cross Bar			
Side-walls	Upper Area and Dividing Welt	Leather Grain Vinyl	Light
	Lower Area and Scuff pad	Leather Grain Vinyl	Medium
Sunshade		Embossed Board	Light
Sunshade Binding		Leather Grain Vinyl	
Headlining		Pattern Vinyl	
Cowl Side Kick Panel		Embossed Board	Medium
Storage Compartment (behind seat)			
Floor Covering		Vinyl Covered Rubber*	

* - Medium color spattered over black

BODY GLASS
BODY GLASS ACTION

 4-Door Sedan (19)	 4-Door Sport Sedan (39)	 2-Door Sedan (11)
 2-Door Utility Sedan (21)	 2-Door Sport Coupe (37)	 2-Door Convertible (67)
 2-Door Station Wagon (15)	 4-Door Station Wagon 6-pass.(35), 9 pass.(45)	 Sedan Delivery (70)
 Sedan Pickup (80)	<p>P-Pivoting, crank vent F-Fixed glass Z-Zip out }-"Monkey" action ~Rotating</p>	

BODY GLASS TYPE AND VISIBILITY AREA

Location	19	39	11	37	21	67	70	80	15	35	45
Windshield	Laminated Safety Plate, one piece, compound curved										
	1740.1	1711.8	1740.1	1711.8	1740.1	1711.8	1740.1				
Front Door	Laminated Safety Plate										
	Ventipane	94.2	75.4	94.2	75.4	94.2	75.4	94.2			
Rear Door Window	Laminated Safety Plate										
	Window	524.1	463.1	726.6	679.9	726.6	646.6	726.6	597.0	726.6	524.1
Rear Quarter	LSP										
	Window	665.8	589.2								722.0
Rear Quarter	LSP										
	Window			623.1	476.2	608.2	288.0			543.6	
	Fixed Vent	109.2								159.6	181.4
Back Window	Safety Solid Plate, crvd										
	Rear Side										1076.7
Back Window	Safety Solid Plate, curved					Plastic	Safety Solid Plate, curved				
		1553.7	1309.1	1553.7	1726.8	1553.7	963.3	579.2	1034.5	623.2	
Total V. A. (sq. in.)	4687.1	4148.6	4737.7	4670.1	4722.8	3685.1	3140.1	3465.8	4964.0	4961.7	

SEAT PADDING CHART

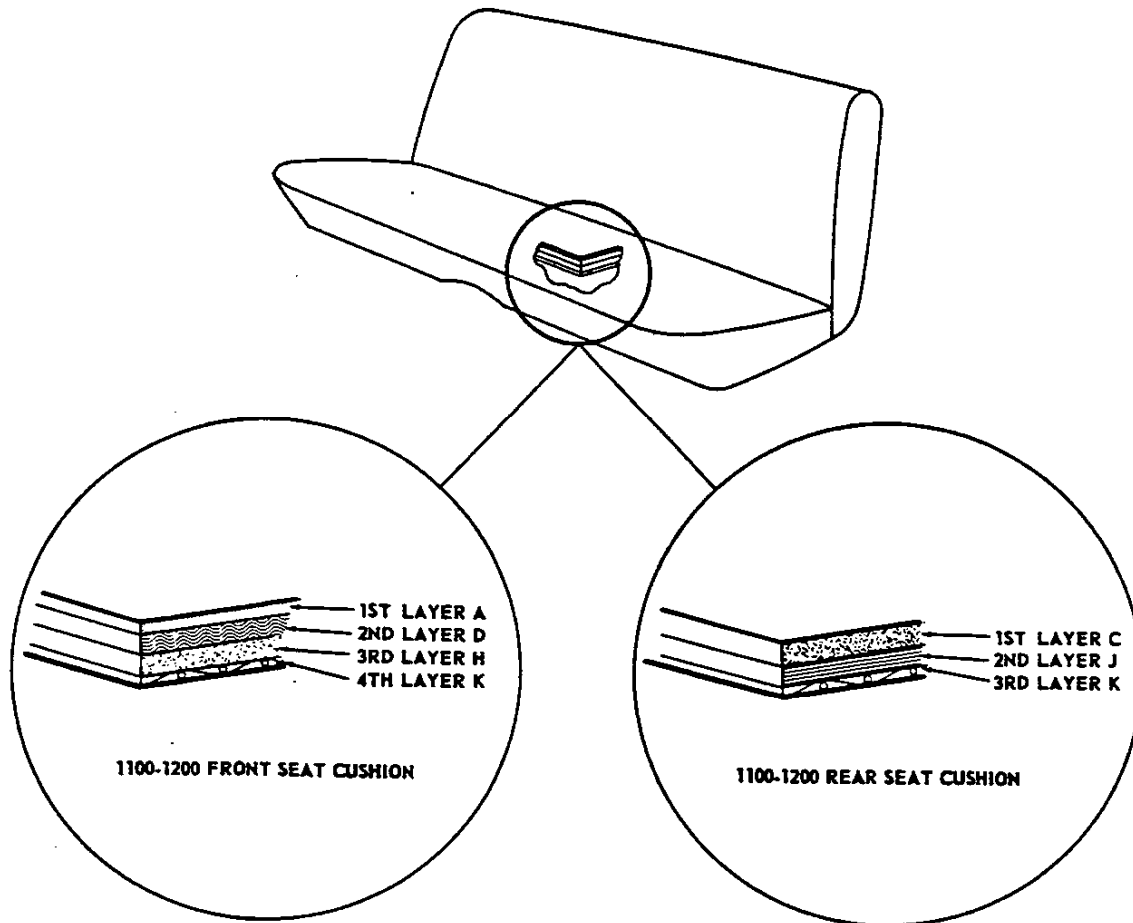

FOR MATERIAL APPLICATION TO OTHER MODELS REFER TO CHART BELOW

Material Application	1100-1200							1500-1600					1700-1800					
	11	15	19	21	35	70	80	11	19	35	39	45	19	35	37	39	67	
Front Seat Cushion	A-D-H-K							A-E-H-K					A-B G-K	A-E H-K	A-B-G-K			
Rear Seat Cushion	C-J-K							A-D-H-L		A-D H-L		A-F M		A-F-K				
Second Seat Cushion			C-J K							A-D H-L		A-D H-L		A-F M				
Third Seat Cushion													*					

* - 1st layer - 1-3/4 oz. cotton topper; 2nd layer - 3" to 1" molded polyurethane pad with integral burlap insulator as 3rd layer.

Item	Material Type
A	Cotton Topper - 3 oz
B	Foam Rubber - 1-3/4"
C	Cotton Pad - 6 oz
D	Polyurethane - 3/4"
E	Polyurethane - 1"
F	Polyurethane - 1-3/4"
G	Cotton Base Pad - 3 oz
H	Cotton Base Pad - 5 oz
J	Jute Pad
K	Wire - Burlap Insulator
L	Burlap - Plastic Insulator
M	Burlap (Composite) Insulator

AMA Specifications – Passenger Car

prepared and distributed by American automobile manufacturers, using uniform questionnaire form
 issued by car manufacturers under auspices of the Automobile Manufacturers Association.

GM DIVISION **MODEL YEAR 1959** **DATE ISSUED 7-15-58** **REVISED 10-16-58**

General Motors Division, General Motors Corporation

MODEL NAME	SYMBOL	MODEL NAME	SYMBOL
Biscayne	1100	Station Wagons	1100 (Brookwood)
Bel Air	1500		1500 (Parkwood, Kingswood)
Impala	1700		1700 (Nomad)

TABLE OF CONTENTS

General Specifications	1	Drive Units	12	Rear Suspension	18	Body & Car - General	25
Engine - Mechanical	2	Brakes	15	Body Dimensions	19	Weights	26
Electrical	8	Front Suspension & Steering	16	Station Wagon	24	Index	27

NOTES:

1. The specifications set forth herein are those in effect at the date of compilation and are subject to change without notice.
2. All specifications are standard for the models under which they are listed.
3. Specifications apply basically to 4-door sedan or equivalent. Body dimensions shown on pages 19-24 include other body models available.
4. All dimensions are nominal engineering dimensions.

GENERAL SPECIFICATIONS

DEL	Additional Information Page No.:	1100-1500-1700 Series (6 cyl.)
Chassis (L-101)	22	119.0
Tread	Front (W-101)	60.3
	Rear (W-102)	59.3
Maximum Overall Dimensions	Length (L-103)	210.9
	Width (W-103)	79.9
	Height (H-101)	56.0
Transmission (Specify trade name - opt., not available)	Manual	3-speed
	Overdrive	Optional
	Automatic	Powerglide (optional)
Axle ratio	Manual	3.55:1
	Overdrive	4.11:1
	Automatic	3.36:1
Tire size	15	7.50 x 14-1/4 ply (a)
Engine	Type, no. cyl., valve arr.	In Line, 6, OHV
	Fuel system (Carb. or inj.)	Carburetor
	Bore and stroke	3.56 x 3.94
	Piston displ., cu. in.	235.5
	Std. compression ratio	8.25:1
	Max. bhp at engine rpm	135 @ 4000
	Max. torque at rpm	217 @ 2000 - 2400

8.00 x 14-1/4 ply on convertible, station wagons, sedan delivery, sedan pickup. Rev. Form 1-58

AMA Specifications – Passenger Car

MAKE OF CAR CHEVROLET MODEL YEAR 1959 DATE ISSUED 7-15-58 REVISED 1-30-59

MODEL 1100-1500-1700 Series (6 Cyl.)

ENGINE—GENERAL

Type, no. cyls., valve arr.		In Line, 6, OHV
Bore and stroke		3.56 x 3.94
Piston displacement, cu. in.		235.5
Bore spacing (C/L to C/L)		4.375" between 2-3 and 4-5, remainder 4.187"
No. system (front to rear)	L. Bank	In Line, 1-2-3-4-5-6
	R. Bank	
Firing order		1-5-3-6-2-4
Compres. ratio (nominal)	Standard	8.25:1
	Optional	None
Cylinder Head Material	Standard	Cast alloy iron
	Optional	None
Cylinder Sleeve - Wet, dry, none		None
Number of mounting points	Front	Two
	Rear	One
Taxable $\text{Dia.}^2 \times \text{No. Cyl.}$ horsepower 2.5		30.4
Published max. bhp at engine RPM*	Standard	135@ 4000
	Optional	None
Published max. torque* (lb. ft. @ RPM)	Standard	217@ 2000 - 2400
	Optional	None
Recommended fuel regular - premium	Standard	Regular
	Optional	N.A.
Recommended idle speed (neutral)		3-speed, 475 RPM in Neutral, Automatic 450 RPM in Drive

ENGINE—PISTONS

Material	Cast alloy aluminum
Description and finish	Flat head, controlled expansion
Weight (piston only) oz.	18.88

* Max. bhp (brake horsepower) and max. torque corrected as defined by SAE Engine Test Code.

(Continued)

Rev. Form 6-57

AMA Specifications – Passenger Car

MAKE OF CAR CHEVROLET MODEL YEAR 1959 DATE: ISSUED 7-15-58 REVISED 10-16-58

MODEL _____ 1100-1500-1700 Series (6 Cyl.)

ENGINE PISTONS (Cont.)

Clearance (limits)	Top land		.033-.042
	Skirt	Top	.0006-.0010 (a)
		Bottom	N.A.
Ring groove depth	No. 1 ring		.199-.205
	No. 2 ring		.199-.205
	No. 3 ring		.199-.205
	No. 4 ring		None

ENGINE—RINGS

Function (top to bottom)	No. 1, oil or comp.		Compression
	No. 2, oil or comp.		Compression
	No. 3, oil or comp.		Oil control
	No. 4, oil or comp.		None
Compression	Description - material, type, coating, etc.		Cast alloy iron, wear resistant
	Width		.0930-.0935
	Gap		.007-.017
Oil	Description - material, type, coating, etc.		Rails, steel; Spacer, stainless steel upper and lower rails chrome plated
	Width		.224-.231
	Gap		.015-.055
Expanders			In oil ring assembly

ENGINE—PISTON PINS

Material			Chromium steel
Length			3.168-3.198
Diameter			.8660-.8665
Type	Locked in rod, in piston, floating, etc.		Locked in rod
	Bushing	In rod or piston	None
		Material	None
Clearance	In piston		.00015-.00025
	In rod		None
Direction & amount offset in piston			Major thrust side-.078

ENGINE—CONNECTING RODS

Material			Forged steel
Weight (oz.)			28.03
Length (center to center)			6.8125
Bearing	Material & Type		Steel backed babbitt
	Overall length		1.008
	Clearance (limits)		.0007-.0027
	End play		.005-.010

(a) Measured 1.29" from top of piston

AMA Specifications – Passenger Car

MAKE OF CAR CHEVROLET MODEL YEAR 1959 DATE ISSUED 7-15-58 REVISED 10-16-58

MODEL 1100-1500-1700 Series (6 Cyl.)

ENGINE—CRANKSHAFT

Material		Forged steel		
Vibration damper type		Oscillating (rubber floating)		
End thrust taken by bearing (No.)		3		
Crankshaft end play		.0035-.0095		
Main bearing	Material & type		Steel backed babbitt, removable	
	Clearance		#1&2-.0008-.0021. #3&4-.0010-.0026	
	Journal dia. and bearing overall length	No. 1	2.6840 x 1.063	
		No. 2	2.7150 x .907	
		No. 3	2.7460 x .979	
		No. 4	2.7770 x 1.189	
		No. 5	None	
		No. 6	None	
No. 7		None		
Dir. & amt. cyl. offset		None		
Crankpin journal diameter		2.311-2.312		

ENGINE—CAMSHAFT

Location		Above and to right of crankshaft		
Material		Cast alloy iron		
Bearings	Material	Steel backed babbitt		
	Number	4		
Type of drive	Gear or chain		Gear	
	Crankshaft gear or sprocket material		Steel	
	Camshaft gear or sprocket material		Bakelite and fabric composition with steel hub	
	Timing chain	No. of links	None	
		Width	None	
		Pitch	None	

ENGINE—VALVE SYSTEM

Hydraulic lifters (Std, opt, NA)		Standard	
Special provision for valve rotation (intake, exhaust)		None	
Rocker ratio		1.477:1	
Operating tappet clearance (indicate hot or cold)	Intake	Zero	
	Exhaust	Zero	
Timing marks on fly-wheel, damper, other		Flywheel	

(Continued)

AMA Specifications - Passenger Car

MAKE OF CAR CHEVROLET **MODEL YEAR** 1959 **DATE ISSUED** 7-15-58 **REVISED** 10-16-58

MODEL 1100-1500-1700 Series (6 Cyl.)

ENGINE-VALVE SYSTEM (cont.)

Timing	Intake	Opens (°BTC)	16°	
		Closes (°ABC)	148°	
		Duration - deg.	214°	
	Exhaust	Opens (°BBC)	146°30'	
		Closes (°ATC)	17°30'	
		Duration - deg.	214°	
Valve opening overlap		33°30'		
Intake	Material		High Alloy steel (8645)	
	Overall length		6.376-6.396	
	Actual overall head dia.		1.870-1.880	
	Angle of seat		31° in head	
	Seat insert material		None	
	Stem diameter		.3410-.3417	
	Stem to guide clearance		.0010-.0027	
	Lift		.3275	
	Outer spring press. and length	Valve closed (lb. @ in.)	62-68@ 1.858	
		Valve open (lb. @ in.)	158-168@ 1.528	
	Inner spring press. and length	Valve closed (lb. @ in.)	None	
		Valve open (lb. @ in.)	None	
	Exhaust	Material		High Alloy steel (21-LN)
		Overall length		4.913-4.933
Actual overall head dia.		1.495-1.505		
Angle of seat		46° in head		
Seat insert material		None		
Stem diameter		.3410-.3417		
Stem to guide clearance		.0010-.0027		
Lift		.3275		
Outer spring press. and length		Valve closed (lb. @ in.)	62-68@ 1.858	
		Valve open (lb. @ in.)	158-168@ 1.528	
Inner spring press. and length		Valve closed (lb. @ in.)	None	
		Valve open (lb. @ in.)	None	

ENGINE-LUBRICATION SYSTEM

Type of lubrication (splash, pressure, nozzle)	Main bearings	Pressure
	Connecting rods	Pressure
	Piston pins	Splash
	Camshaft bearings	Pressure
	Tappets	Pressure
	Timing gear or chain	Nozzle sprayed
	Cylinder walls	Pressure, jet cross sprayed

(Continued)

Rev. Form 6-57

AMA Specifications – Passenger Car

MAKE OF CAR CHEVROLET **MODEL YEAR** 1959 **DATE ISSUED** 7-15-58 **REVISED** 1-30-59

MODEL 1100-1500-1700 Series (6 Cyl.)

ENGINE—LUBRICATION SYSTEM (cont.)

Oil pump type	Gear
Normal oil pressure (lb. @ engine rpm)	35 psi @ 3500
Oil pressure sending unit (elect. or mech.)	Electrical
Type oil intake (floating, stationary)	Stationary
Oil filter system (full flow, partial, other)	Partial flow (optional)
Filter replacement (element, complete)	Element
Capacity of crankcase, less filter-refill (qt.)	5
Oil grade recommended (SAE viscosity and temperature range)	32°F and above - SAE 20W, SAE 20, SAE 10W-30 0°F and above - SAE 10W, SAE 10W-30 0°F and below - SAE 5W, SAE 5W-20
Engine Service Requirement (MM, MS, etc.)	MS or DG

ENGINE—EXHAUST SYSTEM

Type (single, single with cross-over, dual, other)	Single
Muffler No. & type (reverse flow, straight thru, separate resonator)	Reverse flow
Exhaust pipe dia. (O.D.) wall thickness	N.A.
	2.0 x .0625
Tail pipe diameter (O.D. & wall thickness)	1.81 x .0598

ENGINE—FUEL SYSTEM

(See Supplement to Page 6 for Details of Fuel Injection, Supercharger, etc. if used)

Induction type: Carburetor, fuel injection, supercharger.	Carburetor
Fuel Tank	Capacity (gals.) 20 (a)
	Filler location Concealed behind hinged rear license plate (b)
Fuel Pump	Type (elec. or mech.) Mechanical
	Locations Lower right front corner of engine
	Pressure range 3.50-4.50 psi
Vacuum booster (std., optional, none)	None
Fuel Filter	Type Strainer - sintered bronze filter
	Locations Gas tank - carburetor inlet
Make & Model No.	Rochester Products - 7013003 (c)
Number & Type	One, single-barrel downdraft
Carburetor	Barrel size 1.5625
	Choke type Automatic
	Intake manifold heat control (exhaust or water) Exhaust
	Air clnr. type Oil wetted
	Optional Oil bath

- (a) 17 gallons on 6-pass. Station Wagons and Sedan Delivery, 18 gallons on 9-pass. Station Wagon. Rev. Form 1-58
- (b) In left rear quarter panel on Station Wagons and Sedan Delivery.
- (c) Powerglide transmission - Rochester Products 7013000.

AMA Specifications – Passenger Car

MAKE OF CAR CHEVROLET **MODEL YEAR** 1959 **DATE ISSUED** 7-15-58 **REVISED** 10-16-56

MODEL 1100-1500-1700 Series (6 Cyl.)

ENGINE—COOLING SYSTEM

Type (pressure system, atmospheric, other)		Pressure system		
Radiator cap relief valve pressure		13 psi		
Circulation thermostat	Type (choke, bypass)	Choke		
	Starts to open at (°F)	167-172°F		
Water pump	Type (centrifugal, other)	Centrifugal		
	Number of pumps	One		
	Drive (V-belt, other)	V-belt		
	Bearing type	Permanently lubricated, double row ball		
By-pass recirculation type (internal, external)		Internal		
Radiator core type (cellular, tube and fin, other)		Tube on center		
Cooling system capacity	With heater (qt.)	18*		
	Without heater (qt.)	17*		
	Opt. equipment-specify (qt.)	None		
Water jackets full length of cylinder (yes, no)		Yes		
Water all around cylinder (yes, no)		Yes		
Radiator hose	Lower	Number and type (molded, straight)	One, molded	
		Inside diameter	1.75	
	Upper	Number and type (molded, straight)	One, molded	
		Inside diameter	1.50	
	By-pass	Number and type (molded, straight)	None	
		Inside diameter	None	
	Fan	Number of blades & Spacing		4, staggered
		Diameter		17.62
Ratio-fan to crankshaft rev.		.949:1		
Fan cutout type		None		
Bearing type		Double row ball		
*Drive belts (indicate belt used by letter)	Fan		A	
	Generator		A	
	Water Pump		A	
	Power Steering		B	
	Air Conditioning		N.A.	

Rev. Form 1-58

* Drive Belt Dimensions	A	B
Angle of V	37-44°	37-44°
Nominal length (SAE)	40.50 (a)	44.50 (a)
Width	.380 ± .005	.380 ± .005

(a) Pitch length

(*) With 3-speed transmission

AMA Specifications – Passenger Car

MAKE OF CAR CHEVROLET **MODEL YEAR** 1959 **DATE ISSUED** 7-15-58 **REVISED** 1-30-59

MODEL _____ 1100-1500-1700 Series (6 Cyl.)

ELECTRICAL—SUPPLY SYSTEM

Battery	Make and Model		Delco-Remy, 1980158	
	Voltage Rtg. & Total Plates		12 volts - 5 1/2 plates	
	SAE Designation & Amp Hr. Rtg		25MR 53W - 53 amp. hr. @ 20 hr. rate	
	Location		Rt. Front of engine compartment on radiator baffle	
Terminal grounded		Negative		
Generator	Make		Delco-Remy	
	Model		1102096	
	Type		Two brush, shunt wound	
	Ratio—Gen. to Cr/s rev.		2.3:1	
	Gen. cut-in—engine rpm		510	
Regulator	Make		Delco-Remy	
	Model		1119001	
	Type		Vibrator	
	Cutout relay	Closing voltage @ generator rpm	11.8-13.5 @ 1300	
		Reverse current to open	N.A.	
	Regulated	Voltage	13.8-14.8	
		Current	27-33	
	Voltage test conditions	Temperature	Operating	
Load		8-10 amps		
Other		None		

ELECTRICAL—STARTING SYSTEM

Starting motor	Make		Delco-Remy	
	Model		1107652	
	Rotation (drive end view)		Clockwise	
	Engine cranking speed		N.A.	
	Test conditions		Engine at operating temperature	
	Lock test	Amps	N.A.	
		Volts	N.A.	
		Torque (lb. ft.)	N.A.	
	No load test	Amps	49-76	
		Volts	10.6	
RPM (min.)		6200-6900		
Motor control	Switch (solenoid, manual)		Solenoid	
	Starting procedure		Place shift lever in Neutral & depress clutch. (a) Press accelerator once to floor to set automatic choke, then release. Turn ignition key to extreme right position to start engine.	

(a) For Powerglide transmission, place selector lever in "P" (Park) or "N" (Neutral) position.

AMA Specifications – Passenger Car

MAKE OF CAR CHEVROLET **MODEL YEAR** 1959 **DATE ISSUED** 7-15-58 **REVISED** 1-30-59

MODEL 1100-1500-1700 Series (6 Cyl.)

ELECTRICAL—STARTING SYSTEM (cont.)

Motor drive	Engagement type		Positive shift solenoid
	Pinion meshes (front, rear)		Front
	Number of teeth	Pinion	9
		Flywheel	168
Flywheel tooth face width		.1135	

ELECTRICAL—IGNITION SYSTEM

Coil	Make		Delco-Remy
	Model		1115120
	Amps	Engine stopped	1.0
Engine idling		1.8	
Distributor	Make		Delco-Remy
	Model		1112103
	Centrifugal adv. in crankshaft degrees @ engine rpm	Start (rpm)	150-750
		Intermediate points deg. @ rpm	10@ 1400
		Max deg. @ rpm	24-28@ 3500
	Vacuum adv. in crankshaft degrees @ in. Hg.	Start (in. Hg)	6.0
		Intermediate points, deg. @ in. Hg	N.A.
		Max. deg. in. Hg.	15@ 8.5
	Breaker gap (in.)		.016-.021
	Cam angle (deg.)		28-35
Breaker arm tension (oz.)		19-23	
Timing	Crankshaft deg. @ rpm.		5°BTC @ Idle
	Mark location		Flywheel
	Cylinder numbering system (see page 2)		In line, from front to rear (1-2-3-4-5-6)
	Firing order (see page 2)		1-5-3-6-2-4
Spark Plug	Make and model		AC-111
	Thread (mm)		11
	Tightening torque (lb. ft.)		25
	Gap		.033-.038
Cable	Conductor type		Linen core impregnated with an electrical conducting material
	Insulation type		Rubber with neoprene jacket
	Spark plug protector		Plastic

ELECTRICAL—SUPPRESSION

Description	Non-metallic high tension cables
-------------	----------------------------------

AMA Specifications – Passenger Car

MAKE OF CAR CHEVROLET **MODEL YEAR** 1959 **DATE ISSUED** 7-15-58 **REVISED** 10-16-58

MODEL 1100-1500-1700 Series (6 cyl.)

ELECTRICAL—INSTRUMENTS AND SWITCHES

Speed-ometer	Make	AC
	Trip odometer (yes, no)	No
Charge indicator-type		Tall-tale light
Temperature indicator-type		Gauge
Oil pressure indicator-type		Tall-tale light
Fuel indicator-type		Gauge
Other		Parking brake tall-tale light (a)
Ignition switch	Identify positions : in order and cir- cuits controlled	53° Counter clockwise from vertical - "Lock" 13° Counter clockwise from vertical - "Off", unlocked 27° Clockwise from vertical - "On" ign., batt., accessories 57° Clockwise from vertical - "Start", ign., batt., starter spring return to "On" position.
	Provision for illumination	Lamp in lock housing
	Location	On instrument panel right of steering column
Main light- ing switch	Identify positions and lights controlled	Depressed - Off 1st notch - Instrument panel, parking, tail and license lights 2nd notch - Instrument panel, head, tail and license lights Rotate knob clockwise to dim and turn off instrument panel lights Rotate knob counter clockwise to turn on and brighten instru. panel lights and turn on dome light.
Other light switches	Locations and lamps controlled	Toe panel ----- Headlight dimmer Glove compartment ----- Glove comp. lamp (c) Front door hinge pillar ----- Dome lamp (d) Under instrument panel ----- Turn signal lamps Under instrument panel ----- Stop lamps Steering mast jacket ----- Back up lamps (a)
Other switches	Locations and de- vices controlled	Accelerator linkage ----- Overdrive kick down (h) Instrument panel ----- Heater blower (e) Door or qtr. trim panels ----- Power windows (f) Front seat lwr. panel, lh ----- Power seat (f) Instru. panel, center ----- Radio (e) Instru. panel, left ----- W/s wiper, back window (g)
Windshield wiper	Make	Delco
	Type	Electric, single speed (b)
	Vacuum booster provision	None
	Washer provision	Fact Opt. Acc. (pushbutton), or dealer inst. acc. (pushbutton or foot op.) (
Horn	Type	Vibrator
	Number used	2
	Amp draw (each)	8.0-11.0 @ 12.5 volts

- (a) Standard equipment on 1700 Series, dealer inst. acc. on all others Rev. Form 6-57
- (b) Two speed (electric) with pushbutton washers avail. as Factory Optional Accessory.
- (c) Dealer installed accessory on 1100 Series, standard equipment on all others.
- (d) Except 1100 Series.
- (e) Available as Factory Optional Accessory or dealer installed accessory.
- (f) Available as Regular Production Option on 1500-1700 Series.
- (g) Power operated tailgate window std. equip. on 9-pass. wagon (1545) Reg. Prod. Opt. on 1535-1735 wagons.
- (h) Available as Regular Production Option.

AMA Specifications – Passenger Car

MAKE OF CAR CHEVROLET **MODEL YEAR** 1959 **DATE ISSUED** 7-15-58 **REVISED** 10-16-58
MODEL 1100-1500-1700 Series (6 cyl.)

ELECTRICAL—LAMP BULBS

Give quantity used and trade number, e.g., Headlamp 2-5400 S, dual headlight 2-4001, 2-4002.
 Indicate accessories which are not standard equipment by an asterisk following the numbers.

Headlamps & arrangement	Horizontal 2-4001 (inner), 2-4002 (outer)
Headlamp beam indicator	1-53
Parking light	2-1034 (4 cp filaments)
Tail light	4-1034 (4 cp filaments)
Stop light	4-32 cp. filaments of tail light bulbs
Direction signal	Front 2-32 cp. filaments of parking light bulbs
	Rear 4-32 cp. filaments of tail light bulbs
	Indicator 2-57
License plate light	Sta.wgns., sed.del., sed pickup: 1-67, balance of models: 2-67
Instrument light	1100-1500 series: 4-57, 1700 series: 5-57
Ignition lock light	1-53
Back up light	2-1073 (std. equip. on 1700 series, acc.on 1100-1500 series)
Dome light	Sport coupe, sport sedan: 2-90, convt.:2-89, balance of models: 1-1004
Clock light	1-57 (std. equip. on 1700 series, acc on 1100-1500 series)
Radio light	1-1891*
Glove compartment light	1-57 (std. equip. on 1500-1700 series, acc on 1100 series)
Charge indicator	1-57
Oil press.ind.	1-57
Child seat courtesy	1-89 (9-passenger wagon only)
Park brake alarm	1-257 (std. equip. on 1700 series, acc on 1100-1500 series)
Heater	1-53*

ELECTRICAL—FUSE & CIRCUIT BREAKER DATA

Use trade number of fuse, e.g., SFE-10. Indicate circuit breaker by ampere capacity suffixed by letters "C.B.", e.g., 30 C.B. Where fuse or circuit breaker protects multiple circuits indicate first use by a letter and repeat the same letter for all units protected by the same fuse or circuit breaker, e.g., Parking lights SFE-10 (a), Direction indicator same as (a).

Headlamp	15CB (a)
Headlamp beam indicator	(a)
Parking light	(a)
Tail light	3 AG/AGC-15 amp (b)
Stop light	(b)
Direction indicator	Flasher
License plate light	(b)
Instrument light	3 AG/AGC-3 amp (c)
Ignition light	(c)
Back up light	3 AG/AGC-10 amp (d)
Dome light	(b)
Clock	(d)
Clock light	(c)
Radio	Light(all):(c), receiver-manual & p.button:3 AG/AGC 4 amp., sig.seek:3 AG/AGC 7.
Glove compartment light	(b)
Cigarette lighter	Not fused
Park brake alarm	(d)
Water	Light: (c), blower: 3 AG/AGC 10 amp
Overdrive	SAE 9 amp.

AMA Specifications – Passenger Car

MAKE OF CAR CHEVROLET MODEL YEAR 1959 DATE ISSUED 7-15-58 REVISED 10-16-58

1100-1500-1700 Series (6 Cyl.)

MODEL _____

DRIVE UNITS—CLUTCH (Manual Transmission)

Make & type	Own, single plate	
Type pressure plate springs	Diaphragm	
Total plate pressure (lb.)	1325-1500 (a)	
No. of clutch driven discs	One	
Clutch facing	Material	Molded or woven composition
	Outside & inside dia.	9.50 x 6.0 (b)
	Total eff. area (sq.in.)	85.22 (c)
	Thickness	.125 (d)
	Engagement cushioning method	Spring
Release bearing	Type & method of lubrication	Ball bearing; sealed
Torsional damping	Methods: springs, friction material	Springs at hub

DRIVE UNITS—TRANSMISSIONS

Manual (std. or opt.)	Standard
Manual with overdrive (std. or opt.)	Optional
Automatic (std. or opt.)	Powerglide (optional)

DRIVE UNITS—MANUAL TRANSMISSION

Number of forward speeds	Three		
Transmission	In first	2.94:1	
	In second	1.68:1	
	In third	1.00:1	
	In fourth	None	
	In reverse	2.94:1	
Synchronous meshing, specify gears	2nd & 3rd		
Lubricant	Capacity (pt.)	2	
	Type recommended	A-9 mineral oil	
	SAE viscosity number	Summer	SAE-90
		Winter	SAE-90
		Extreme cold	SAE-80

- (a) 1575-1725 with heavy duty clutch
- (b) 11.0 x 6.5 with H.D. clutch
- (c) 123.70 sq. in. with H.D. clutch
- (d) .133 with H.D. clutch

AMA Specifications – Passenger Car

MAKE OF CAR CHEVROLET MODEL YEAR 1959 DATE ISSUED 7-15-58 REVISED 10-16-58
 MODEL _____ 1100- 1500-1700 Series (6 Cyl.)

DRIVE UNITS—MANUAL TRANSMISSION WITH OVERDRIVE

For transmission data see manual transmission section

Overdrive	Type (planetary or other)		Planetary	
	Manual lockout (yes, no)		Yes	
	Downshift accelerator control (yes, no)		Yes	
	Minimum cut-in speed		27	
	Gear ratio		0.70:1	
	Lu- bri- cant	Capacity (Overdrive only)		1 pint
		Separate filler (yes, no)		No
		Type recommended		A-9 mineral oil
		SAE vis- cosity number	Summer	SAE-90
			Winter	SAE-90
Ext. cold	SAE-80			

DRIVE UNITS—AUTOMATIC TRANSMISSION

Trade name		Powerglide						
Type describe		Torque converter with planetary gears						
Method of Selection (Lever, Push Button or other)		Lever						
Selector Pattern		P-R-N-D-L						
List gear ratios Selector Pattern and indicate which are used in each selector position		<table style="margin-left: 20px;"> <tr> <td>Drive</td> <td>1.82&1.0:1 (a)</td> </tr> <tr> <td>Low</td> <td>1.82:1</td> </tr> <tr> <td>Rev.</td> <td>1.82:1</td> </tr> </table>	Drive	1.82&1.0:1 (a)	Low	1.82:1	Rev.	1.82:1
Drive	1.82&1.0:1 (a)							
Low	1.82:1							
Rev.	1.82:1							
Max. upshift speeds—drive range		53						
Max. kickdown speeds—drive range		40						
Torque converter	Number of elements	3						
	Max. ratio at stall at engine rpm	2.1:1						
	Type of cooling (air, water)	Water						
Lubricant	Capacity—refill (pt.)	9						
	Type recommended	Type "A", Suffix "A"						
Special transmission features								

(a) Total transmission torque multiplication - 3.82:1.

AMA Specifications – Passenger Car

MAKE OF CAR CHEVROLET **MODEL YEAR** 1959 **DATE ISSUED** 7-15-58 **REVISED** 10-16-58

MODEL 1100-1500-1700 Series (6 cyl.)

DRIVE UNITS—PROPELLER SHAFT

Number used		2
Type (exposed, torque tube)		Exposed
Outer diameter x length* x wall thickness	Manual transmission	Front - 2.003 x 30.12 x .097 Rear - 2.003 x 35.00 x .097
	Overdrive transmission	Front - 2.003 x 24.97 x .097 Rear - 2.003 x 35.00 x .097
	Automatic transmission (Powerglide)	Front - 2.003 x 24.03 x .097
		Rear - 2.003 x 35.00 x .097
Inter-mediate bearing	Type (plain, anti-friction)	Anti-friction
	Lubrication (fitting, prepack)	Prepack
Universal joints	Make	Own
	Number used	3
	Type (ball and trunnion, other)	Yoke and spider (trunnion)
	Bearing	Type (plain, anti-friction)
Lubric. (fitting, prepack)		Prepack
Drive taken through (torque tube or arms, springs)		Upper and lower control arms
Torque taken through (torque tube or arms, springs)		Upper and lower control arms

DRIVE UNITS—REAR AXLE

Description - (incl. limited slip differential)		Standard axle - Semi-floating, overhung pinion gear Optional "Positraction" axle - Semi-floating, overhung pinion gear. Spicer limited slip with dual 4 disc clutches applied by reaction torque through the differential side gears	
Drive Pinion Offset		1.5	
No. of differential pinions		2 (a)	
Gear ratio and No. of teeth	Automatic transmission	3.36:1, 11-37	
	Overdrive trans.	4.11:1, 9-37	
	Manual transmission	3.55:1, 9-32	
Ring and pinion pitch diameter & O.D.		8.375 p.d. & o.d.	
Pinion adjustment (shim, other)		Shim	
Pinion bearing adj. (shim, other)		None	
Wheel bearing type		Ball	
Lubricant	Capacity (pt.)	4	
	Type recommended	A-9 hypoid	
	SAE viscosity number	Summer	SAE-90
		Winter	SAE-90
Extreme cold		SAE-90	

*Center to center of universal joints, or to centerline of rear attachment.

(a) 4 pinions in Positraction axle.

AMA Specifications - Passenger Car

MAKE OF CAR CHEVROLET MODEL YEAR 1959 DATE ISSUED 7-15-58 REVISED 1-30-59

MODEL 1100-1500-1700 Series (6 cyl.)

DRIVE UNITS—WHEELS

Type & material		Short spoke disc, pressed steel
Rim (size and flange type)		11x5J (a)(e)
Attachment	Type (bolt or stud)	Stud
	Circle diameter	4.75
	Number and size	5.7/16-20

DRIVE UNITS—TIRES

Standard	Size & ply	7.50 x 14-4 ply (b)
	Type - Nylon, etc.	Rayon
	Sidewall color	Black
Optional	Size & ply	7.50 x 14-4 ply (c)
	Type - Nylon, etc.	Rayon
	Sidewall color	White
Rev/mile at 30 mph		784 (d)
Inflation press.(cold)	Front	24 psi
	Rear	24 psi

BRAKES—SERVICE

Type		Servo-4 wheel hydraulic		
Power brake type		Vacuum power unit with regular production mstr. cyl.		
Effective area (sq. in.)		185.6		
Gross lining area (sq. in.)		199.5		
Percent brake effectiveness-front		56%		
Drum	Diameter	Front	11	
		Rear	11	
Type and material		Composite-cast alloy iron rim, pressed steel web		
Bonded or riveted		Bonded		
Brake lining	Front Shoe	Material	Full molded asbestos composition	
		Size (length x width x thickness)	Front wheel	9.30 x 2.75 x .175
			Rear wheel	9.30 x 2.00 x .175
	Segments per shoe			
	Rear Shoe	Material	Full molded asbestos composition	
		Size (length x width x thickness)	Front wheel	11.70 x 2.75 x .175
Rear wheel			11.70 x 2.00 x .175	
Segments per shoe		1		
Wheel cylinder bore	Front	1.125		
	Rear	1.000		
Master cylinder bore		1.000		
Available pedal travel		6.4		
Line pressure at 100 lb. pedal load		725 (approx.)		
Shoe clearance adjustment		Adjust to light drag and back off 7 notches		

- Rev. Form 1-58
- (a) Modified used as optional in regular production
 - (b) 8.00 x 14-4 ply black std. equip. on convertible, sta. wgn.s., sed.del., sed.pickup.
 - (c) Except convertible, sta. wgn.s., sed.del., sed. pickup. 8.00 x 14-4 ply black or white available on all models 8.50 x 14-4 ply black avail. on sed. del. & sed. pickup.
 - (d) 770 on 8.00 x 14-4 ply, 751 on 8.50 x 14-4 ply.

(e) 1100-1500-1700 Series Passenger station wagon model 1515.

AMA Specifications – Passenger Car

MAKE OF CAR CHEVROLET **MODEL YEAR** 1959 **DATE ISSUED** 7-15-58 **REVISED** 10-16-58
MODEL 1100-1500-1700 Series (6 cyl.)

BRAKES—PARKING

Type of control		Apply: Pendulum foot pedal. Release: Integral hand lever
Location of control		Under instrument panel, left of steering column
Operates on		Rear service brakes
If separate from service brakes	Type (Internal or external)	None
	Drum diameter	None
	Lining size (length x width x thickness)	None

FRAME or UNITIZED CONSTRUCTION

Type and description	All welded "X" frame with box girder side rails, box section front suspension crossmember, "Z" section intermediate rear crossmember, channel section rear crossmember and reinforced box girder center beam.
----------------------	---

SUSPENSION—GENERAL (See Supplemental page 16 for details on Air Suspension)* (a)

Provision for car leveling		Front stabilizer bar (b)
Provision for brake dip control		Mounting angle of front upper control arms
Provision for acc. squat control		Geometry of rear suspension
Special provisions for car jacking		None
Shock absorber front & rear	Type	Direct-double acting
	Make	Delco
	Piston dia.	1
Other special features		

SUSPENSION—FRONT

Type and description	Independent short and long arm, spherical joint outer pivots, rubber bushed inner pivots, coil springs.
----------------------	---

(Continued) Rev. Form 1-58

- (a) Air suspension not available on 6 cyl. models
- (b) Used only on all station wagons, and Impala models

* Air Suspension:
 Air spring type
 Compressor data
 type
 make
 drive ratio
 Normal operating pressures
 spring rates
 leveling data

AMA Specifications – Passenger Car

MAKE OF CAR CHEVROLET **MODEL YEAR** 1959 **DATE: ISSUED** 7-15-58 **REVISED** 1-30-59
MODEL 1100-1500-1700 Series (6 cyl.)

SUSPENSION FRONT (cont.)

Spring	Type		Coil
	Material		High alloy steel
	Size (coil design height & I.D.; bar length x dia.)		10.30 x 3.800; 128.5 x .664
	Spring rate (lb. per in.)		370
	Rate at wheel (lb. per in.)		129
	Design load (lb. @ design height)		1855 @ 10.30
Stabilizer	Type (link, linkless, frameless)		Link (a)
	Material & bar diameter		H.r. steel, .6875

STEERING

Mechanical (std., opt., NA)			Standard	
Power (std., opt., NA)			Optional	
Wheel diameter			17"	
Turning diameter	Outside front	Wall to wall (l. & r.)	43.6 ft.	
		Curb to curb (l. & r.)	40.8 ft.	
	Inside rear	Wall to wall (l. & r.)	23.2 ft.	
		Curb to curb (l. & r.)	24.5 ft.	
Outside wheel angle with inside wheel at 20°			17°54'	
Mechanical	Gear	Type	Semi-reversible, recirculating ball	
		Make	Saginaw	
		Ratios	Gear	24:1
			Overall	28:1
	No. wheel turns		5.80	
Power	Type		Hydraulic. Power cylinder in linkage	
	Make		Saginaw	
	Trade name		Power-Touch	
	Gear	Type		Semi-reversible, recirculating ball
		Ratios	Gear	20:1
			Overall	24:1
	Pump driven by		Extension of generator shaft	
	Number wheel turns		5.20	
	Linkage	Type		Relay
		Location (front or rear of wheels, other)		Front
Drag link (trans. or longit.)			None	
Tie rods (one or two)			Two	

(a) Used only on all station wagons and Impala models

(Continued)

Rev. Form 1-58

AMA Specifications – Passenger Car

MAKE OF CAR CHEVROLET **MODEL YEAR** 1959 **DATE ISSUED** 7-15-58 **REVISED** 1-30-59
MODEL 1100-1500-1700 Series (6 Cyl.)

STEERING (cont.)

Steering Axis	Inclination at camber (deg.)		7°11'
	Bearings (type)	Upper	Spherical joint, non-metallic bearing liner
		Lower	Spherical joint, non-metallic bearing liner
		Thrust	(a)
Wheel alignment (range and preferred)	Caster (deg.)		8° / 30'
	Camber (deg.)		/30' /30'
	Toe-in (outside tread-inches)		1/16 - 1/8
Steering spindle & joint type			Forged steel with integral brake cyl. mount, detachable at arms.
Wheel spindle	Diameter	Inner bearing	1.2192-1.2197
		Outer bearing	.7191-.7196
	Thread size		3/16-20
	Bearing type		Ball

SUSPENSION—REAR

Type and description			Sh-link, upper control arm & bar, lower control arms, coil spring	
Drive and torq. taken through (see page 14)			Upper & lower control arms	
Spring	Type		Coil	
	Material		High alloy steel	
	Size (length x width, coil design height and I.D.; bar length & dia.)		9.55 x 3.618; 124.0 x .587	
	Spring rate (lb. per in.)		265	
	Rate at wheel (lb. per in.)		112	
	Design load (lb. at design height)		1560 @ 9.55	
	Mounting insulation type		None	
	If leaf	No. of leaves		None
		Inserts	Type and size	None
			Material	None
Shackle (comp. or tens.)		None		
Stabilizer	Type (link, linkless, frameless)		None	
	Material		None	
Track bar type			Lateral, frame to rear axle	

(a) Vehicle load carried on lower spherical joints, no auxiliary bearings required for steering motion.

AMA Specifications – Passenger Car

MAKE OF CAR CHEVROLET **MODEL YEAR** 1959 **DATE: ISSUED** 7-15-58 **REVISED** 1-30-59

BODY—GENERAL DEFINITIONS

NOTE: Included in the dimension definitions listed on this and the following pages are those which have been adopted by the S.A.E. These are indicated by a number following the type of dimension, e.g. L 3. Additional dimensions have been added by the AMA Specifications Body Sub-Committee for inclusion in the Questionnaire. These are shown by an additional letter, e.g., HA. Symbol "a" added as suffix to SAE dimensions indicates an AMA modification. The dimensions are developed from the following basic points:

1. Front and rear seat free "A" points are taken 5" forward of vertical tangent to seat back 15" from center of body.
2. Front and rear seat "B" points are located on seat back 15" from center of body at height of horizontal tangent to top of seat cushion.
3. Front seat is in the full down and normal rearmost position.
4. Loaded position—5 passenger, front 300 lb., rear 450 lb.; includes spare wheel, tire and tools, and full complement of gas, oil, water, and tires to recommended pressure, etc.
5. C/L (centerline).
6. D. L. O. (daylight opening, exposed glass dimension - pages 21, 23 & 25).
7. Ramp breakover angle (page 21) is the supplement of the included ramp angle (180° minus the included ramp angle) over which a car can pass without hanging up.

MODEL <u>1100-1500-1700 Series (6 cyl)</u>	<u>4-Door Sedan</u>	<u>4-Door Station Wagon</u>
---	---------------------	-----------------------------

BODY—TRUNK DIMENSIONS

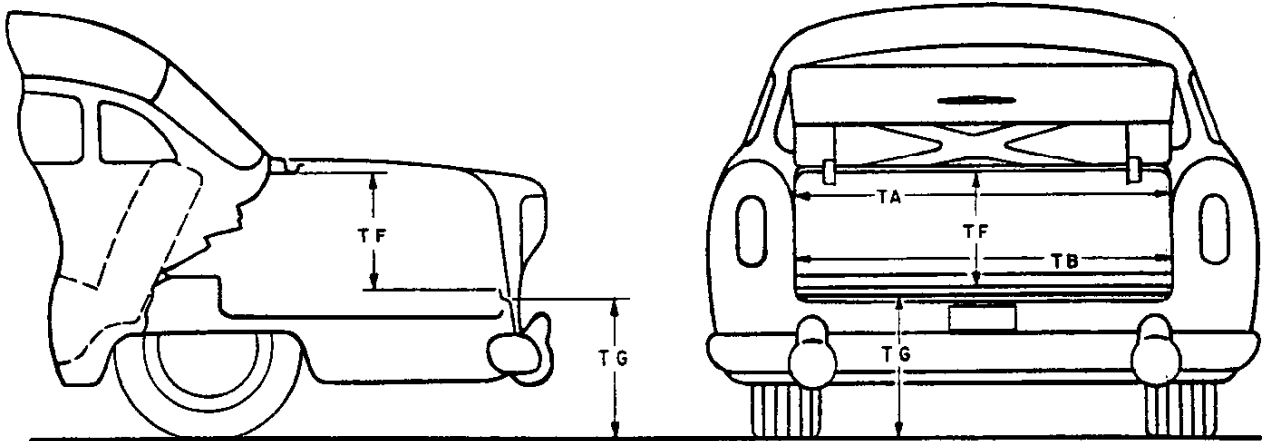

Usable trunk luggage capacity (see Section H1 of SAE Automotive Drafting Standards)	19.248 cu.ft. (b)	- (b)
TA— Width across the top	52.0	-
TB—Width across the bottom	-	-
TF—Vertical dimension at C/L from bottom to top of opening.	7.0	-
TG—Vertical height from ground to trunk lower opening (normal surface of outside sheet metal - loaded)	28.4	-
Position of spare tire stowage	Nearly vertical, rh	Horizontal (a)
Method of holding lid open	Torsion bars, counterbal.	-

(a) Vertical in rh sidewall on 9-passenger only.

(b) Overall - sedans 30.0 cu.ft.; sport coupe 32.0 cu.ft. (with luggage set 20.1); convertible 29.5 cu.ft. (with luggage set 19.3); station wagon 92.0 cu.ft. (rear seat folded)

AMA Specifications – Passenger Car

MAKE OF CAR CHEVROLET MODEL YEAR 1959 DATE ISSUED 7-15-58 REVISED 10-16-58

BODY—HEIGHT DIMENSIONS--INTERIOR

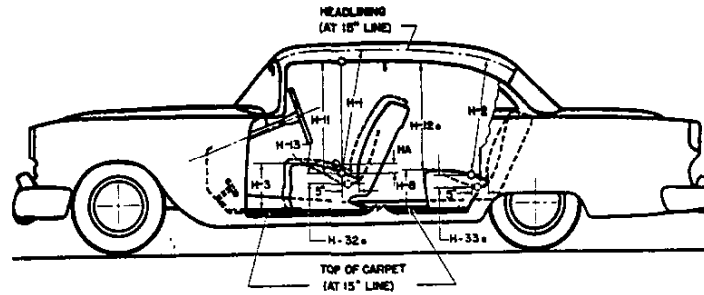

MODEL 1100-1500-1700 Series (6 cyl)	4-Door Sedan	4-Door Station Wagon
H1. Front headroom—from free "A" pt. to headlining at 8° back of vertical on 15" line. (For "A" pt. see note 1, page 19)	36.1	35.8
H2. Rear headroom—from free "A" pt. to headlining at 8° back of vertical on 15" line.	34.3	36.9 (a) 34.0 (b)
H3. Front cushion height above low point on floor carpet on 15" line (front edge of cushion).	9.2	9.3
H8. Rear cushion height above low point on floor carpet on 15" line (front edge of cushion).	13.8	12.2 (a) 16.0 (b)
H11. Entrance—front—cushion free "A" point to bottom windcord vertical.	29.3	29.2
H12a. Entrance — rear — top of cushion at vertical tangent to front of rear seat, to bottom of windcord in rear.	28.0	29.5
H13. Steering wheel clearance to seat cushion taken on arc (wheel turned for min. clearance).		5.2
HA. Front seat maximum vertical rise at free "A" point.		.5
HF. Front seat maximum vertical rise of free "A" point with multiple-position seat.		1.8
H32a. Front seat depressed depth — vertical dimension from free "A" point to depressed "A" point.		4.4
H33a. Rear seat depressed depth — vertical dimension from free "A" point to depressed "A" point.	4.5	4.4 (a) 3.5 (b)

Rev. Form 1-58

- (a) Rear seat (all wagons)
- (b) Third seat (9-pass. wagon only)

AMA Specifications – Passenger Car

Page 21

MAKE OF CAR CHEVROLET MODEL YEAR 1959 DATE: ISSUED 7-15-58 REVISED 1-30-59

BODY—HEIGHT DIMENSIONS—EXTERIOR

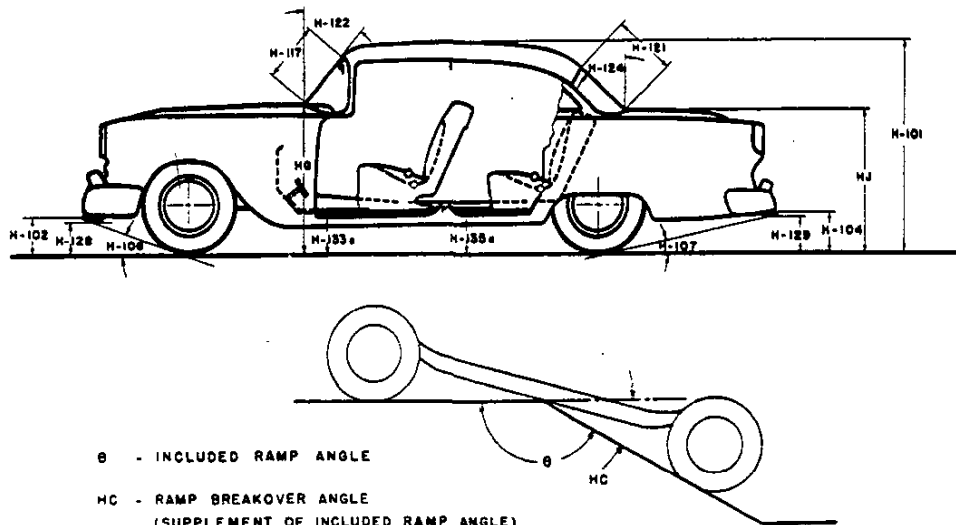

MODEL	1100-1500-1700 Series (6 Cyl.)	
	4-Door Sedan	4-Door Station Wagon
H101. Overall height - loaded.	56.0	56.3
HB. Overall height - curb weight.	58.1	58.4
H102. Front bumper bottom to ground at normal section.		14.9
H104. Rear bumper bottom to ground at normal section.		15.4
H106. Angle of appr.-fr. tire static loaded rad. to interfering pt. on fr. bumper, gd., other.		26°
H107. Angle of dep.-fr. tire static loaded rad. to interfering pt. on rr. bumper, gd., other.		12°45'
HC. Ramp breakover angle.*		12°30'
H117. Windshield DLO-slant height.		26.6
H121. Backlight DLO*-max., slant height.	22.7	14.0
H122. Windshield slope angle to vertical line on car axis.		48°45'
H124. Backlight slope angle to vertical line on car axis.	59°0'	25°0'
H128. Ground to bottom of front bumper guard.		10.8
H129. Ground to bottom of rear bumper guard.		11.4
H133a. Bottom of front door to ground, min. dimension - car loaded.	11.7	11.9
H135a. Bottom of rear door to ground, min. dimension - car loaded.	11.5	11.7
HD. Min. road clear. (5 pass. load) & loc.	6.0 (at muffler)	
HE. Min. road clearance at rear axle.	7.3	
HG. Hood at rr. to grd.-vert. dim. excl. molding, fr. hood opening line at cowl (curb wt.)	N.A.	
HH. Max. ht., fr. grd. frt. of windshield (curb wt.)	N.A.	
HJ. Max. ht. fr. grd. back of r. window (curb wt.)	N.A.	

* See Notes, page 19.

AMA Specifications — Passenger Car

MAKE OF CAR CHEVROLET **MODEL YEAR** 1959 **DATE ISSUED** 7-15-58 **REVISED** 10-16-58

BODY—LENGTH DIMENSIONS

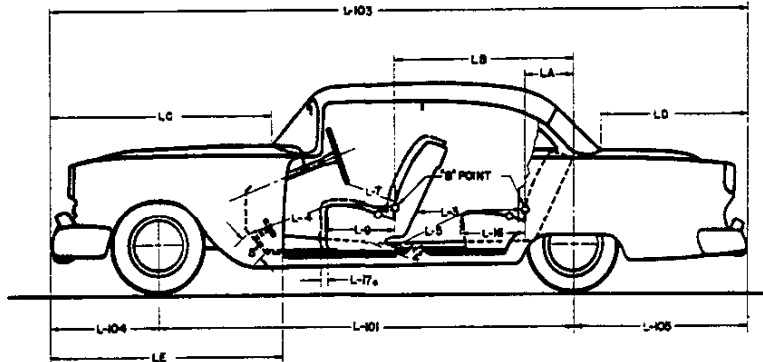

MODEL	1100-1500-1700 Series (6 Cyl.)	4-Door Sedan	4-Door Station Wagon
Interior	L3. Rear compartment of front seat back to rear seat back.	29.2	29.3 (a) 34.5 (b)
	* L4. Leg room—front—ball of foot to top of seat to seat back—15" line.	45.0	44.8
	* L5. Leg room—rear—from ball of foot to top of seat cushion and to seat back—	42.8	41.7 (a) 38.3 (b)
	L7. Steering wheel clearance to seat back taken on arc.	14.2	
	* L9. Front seat depth (front edge to vert. tan. to seat back on 15" line).	19.0	18.3
	* L16. Depth of rear seat (front edge to seat back).	18.3	18.6 (a) 18.0 (b)
	L17a. Total adjustment of front seat at front lower seat frame.	4.7 (c)	
	LA. Rear seat "B" point to center line of rear axle.	18.5	18.9 (a) 12.6 (negative) (b)
	LB. Front seat "B" point to center line of rear axle.	53.7	
	LC. Front of car to base of windshield.	52.8	
	LD. Rear of car to base of rear window or upper structure.	45.4	44.7
	LE. Front of car to front edge of front door.	65.1	
	Exterior	L101. Wheelbase.	119.0
L103. Overall length (bumper to bumper inc. guards).		210.9	
L104. Overhang—front including bumper guards.		32.6	
L105. Overhang—rear including bumper guards.		59.3	

* Dimension taken on 15" line—see notes 1 & 2, page 19.

- (a) - Rear seat (all wagons).
- (b) - Third seat (9-pass. wagon only).
- (c) - 4.8 on multiple position seat.

AMA Specifications - Passenger Car

MAKE OF CAR CHEVROLET **MODEL YEAR** 1959 **DATE ISSUED** 7-15-58 **REVISED** 1-30-59
BODY-WIDTH DIMENSIONS

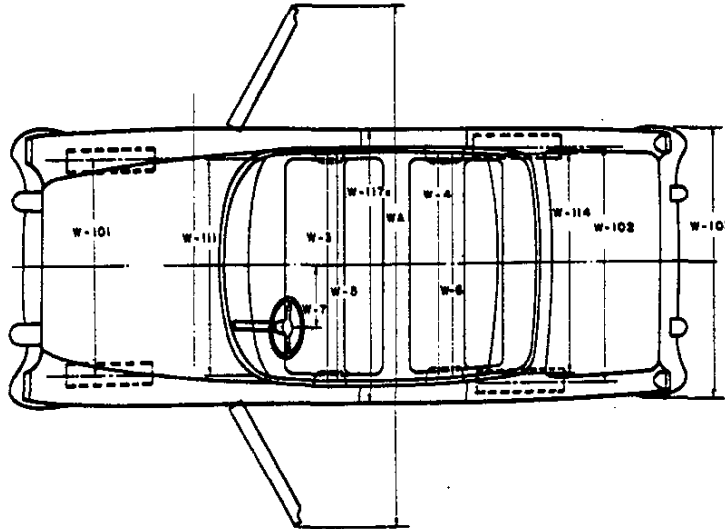

MODEL 1100-1500-1700 Series (6 Cyl.)		4-Door Sedan	4-Door Station Wagon
Interior	W3. Front shoulder room, at garnish moulding height or nearest interference 5" forward of seat back.	60.5	60.5
	W4. Rear shoulder room, at garnish moulding height or nearest interference 5" forward of seat back.	59.7	59.2 (a) 57.5 (b)
	W5. Front hip room, at top of seat 5" forward of vert. tan. to seat back.	66.1	66.1
	W6. Rear hip room, at top of seat 5" forward of vert. tan. to seat back.	65.5	66.0 (a) 66.5 (b)
	W7. Steering wheel center to center of body.	15.9	
Exterior	W101. Front tread at ground.	60.3	
	W102. Rear tread at ground.	59.3	
	W103. Max. overall width of car including bumpers or mouldings.	79.9	
	WA. Max. overall width of car with doors open.	148.9 front (c)	148.9 front (c)
	W111. Windshield DLO, max. width.	64.6	
	W114. Back window DLO, max. width.	61.2	45.4
	W117a. Max. body width at center pillar, less hardware and applied moldings.	79.1	79.0

Rev. Form 1-58

- (a) - Rear seat (all wagons).
- (b) - Third seat (9-pass. wagon only).
- (c) - Doors in check position.

AMA Specifications – Passenger Car

MAKE OF CAR CHEVROLET **MODEL YEAR** 1959 **DATE ISSUED** 7-15-58 **REVISED** 1-30-59

STATION WAGON—CARGO SPACE DIMENSIONS

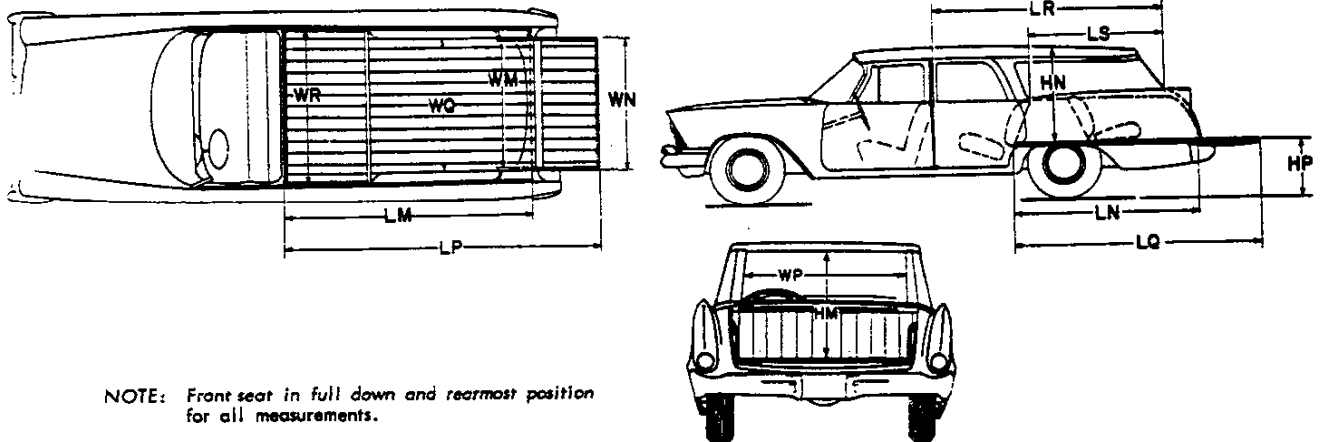

NOTE: Front seat in full down and rearmost position for all measurements.

MODEL <u>1100-1500-1700 Series</u> <u>(6 Cyl.)</u>	<u>4-Door Station Wagon</u>
LM Floor length from bottom of front seat to inside of tail gate in raised position.	94.8
LN Floor lgth. from bottom of second seat to inside of tail gate in raised position.	60.0
LP Floor lgth. from bottom of front seat to end of tail gate in lowered position.	120.1
LQ Floor lgth. from bottom of second seat to end of tail gate - tail gate lowered.	85.3
HM Maximum hgth. of rear opening - tail gate lowered.	26.7
WM Rear end opening width at floor.	47.6
WN Rear end opening width at top of tail gate.	46.0
WQ Minimum distance between wheelhouses.	46.4
WP Maximum width of rear opening above raised tail gate.	44.6
WR Maximum width of cargo space at floor.	66.0
LR Cargo horizontal distance from top rear of front seat back to top of tail gate.	84.2
LS Cargo horizontal distance from top rear of second seat back to top of tail gate.	48.2
HN Maximum height of roof above floor at center line of car.	32.1
HP Platform height of end of lowered tail gate - curb weight.	27.5
Third Seat - facing direction.	Rearward (a)

(a) - 9-passenger model only.

AMA Specifications - Passenger Car

Page 25

MAKE OF CAR CHEVROLET **MODEL YEAR** 1959 **DATE ISSUED** 7-15-58 **REVISED** 1-30-59

MODEL 1100-1500-1700 Series (6 Cyl.)

BODY - MISCELLANEOUS INFORMATION

Drs. hinged (front, rear)	Front doors	Front
	Rear doors	Front
Type of finish (lacquer, enamel).		Acrylic lacquer
Hood hinge location (front, rear).		Rear
Hood counterbalanced (yes, no).		Yes
Hood release control (internal, external).		External
Vehicle (Serial) No. Location		Left front body hinge pillar
Engine No. location		Right side of cyl. block to rear of distributor
Theft protection - type		Shielded ign. lock terminals, key removable in "lock" or "on" pos. only
Vent window control method (crank, friction pivot).		Crank
Windshield type (single curved, compound curved, other)		Single, compound curved
Rear window type (flat, curved, one piece, three piece)		Single curved
Side glass type (curved, flat)		Flat
Windshield glass area D.L.O.		1740.1 (a)
Backlight glass area D.L.O.		(b)
Total glass area D.L.O.		(c)

BODY - TYPES AND STYLE NAMES -

Body type, number of passengers & style names; use manufacturer's code for series & body style.

BODY STYLES:		CODES
<u>Biscayne</u>	1111	2-door sedan - 6-passenger
	1119	4-door sedan - 6-passenger
	1121	2-door utility sedan - 3-passenger
	1170	2-door sedan delivery - 1-passenger
	1180	2-door sedan pickup - 3-passenger
<u>El Camino</u>	1511	2-door sedan - 6-passenger
	1519	4-door sedan - 6-passenger
	1539	4-door sport sedan - 5-passenger
<u>Impala</u>	1719	4-door sedan - 6-passenger
	1737	2-door sport coupe - 5-passenger
	1739	4-door sport sedan - 5-passenger
	1767	2-door convertible - 5-passenger
<u>Station Wagon</u>	1115	2-door station wagon - 6-passenger (Brookwood)
	1135	4-door station wagon - 6-passenger (Brookwood)
	1535	4-door station wagon - 6-passenger (Parkwood)
	1545	4-door station wagon - 9-passenger (Kingwood)
	1735	4-door station wagon - 6-passenger (Nomad)

(a) - Impala sport coupe, sport sedan, convertible: 1711.8

(b) - 2-4 door sedans: 1553.7, sport sedan: 1309.1, sport coupe: 1726.8, convertible (plastic): 963.9, station wagons: 623.2, sedan delivery: 579.2, sedan pickup: 1034.5

(c) - 2-door sedan: 4737.7 (utility sedan: 4722.8), 4-door sedans: 4687.1, sport sedan: 4148.6, sport coupe: 4670.1, convertible (includes plastic backlight): 3685.1, 2-door station wagon: 4964.0, 4-door station wagon: 4961.7, sedan, delivery: 3140.1, sedan pickup: 3465.8

AMA Specifications -- Passenger Car

Page 26

MAKE OF CAR CHEVROLET MODEL YEAR 1959 DATE ISSUED 7-15-58 REVISED 2-12-59

MAJOR OPTIONAL ITEMS - WEIGHTS 1100-1500-1700 Series 6-Cyl.

Model	CURB - WEIGHT - POUNDS			% PASS. WEIGHT DISTRIBUTION				SHIPPING * WEIGHT
	Front	Rear	Total	Pass. In Front		Pass. In Rear		
				Front	Rear	Front	Rear	
1111- 2-door sedan	1880	1810	3690	32	68			3535
1119- 4-door sedan	1895	1870	3765	32	68			3605
1121- utility sedan	1865	1775	3640	47	53			3480
1170- sedan delivery	1805	1975	3780	47	53%			3635
1180- sedan pickup	1905	1825	3730	47	53%			3585
1511- 2-door sedan	1885	1790	3675	32	68			3515
1519- 4-door sedan	1905	1855	3760	32	68			3600
1719- 4-door sedan	1930	1850	3780	32	68			3625
1737- sport coupe	1915	1810	3725	37	63			3570
1739- sport sedan	1940	1885	3825	35	65			3665
1767- convertible	1955	1860	3815	37	63			3660
1115- 2-door sta. wgn.	1830	2180	4010	32	68			3870
1135- 4-door sta. wgn.	1860	2235	4095	32	68			3955
1535- 4-door sta. wgn.	1865	2240	4105	32	68			3965
1545- 4-door sta. wgn.	1845	2320	4165	17	83			4020
1735- 4-door sta. wgn.	1875	2250	4125	32	68			3980

% - Plus 100% of payload

Accessories & Equipment Differential Weights	Remarks
Brakes, power	15
Heater, air flow	24
Heater, recirculating	18
Radio & ant. manual	9
Radio & ant., pushbutton	12
Seat, power	19
Steering, power	22
Trans. - Overdrive	35
Trans. - Powerglide	107
Window, power	9

* These are weights that are reported to states for licensing purposes.

AMA Specifications -- Passenger Car

PAGE 27

INDEX

SUBJECT	PAGE NO.	SUBJECT	PAGE NO.
Air Suspension	16	Lamp Bulbs	11
Angles of Approach, Departure	21	Legroom	22
Automatic Transmission	1, 13	Lengths - Car, & Body interior	1, 22
Axis; Steering	18	Lifters, Valve	4
Axle, Rear	1, 14	Linings - Clutch, Brake	12, 15
Battery	8	Lubrication	5, 6, 12, 13, 14
Bearings, Engine	3, 4, 7	Motor, Starting	8
Belts - Fan, Generator, Water Pump	7	Muffler	6
Body - General Information, Types	19, 25	Overdrive	13
Height Dimensions	21	Piston Pins & Rings	3
Length Dimensions	22	Pistons	2, 3
Overall Dimensions	1, 21, 22, 23	Power Brakes	15
Trunk Capacities, Opening Dimensions	19	Power Steering	17
Width Dimensions	23	Propeller Shaft, Universal Joints	14
Brakes - Parking, Service, Power	15, 16	Pumps - Oil, Fuel	6
Water	7	Radiator, Hoses	7
Camber	18	Ramp Break-over Angle	21
Camshaft	4	Ratios - Axle	1, 14
Capacities		Compression	1, 2
Cooling System	7	Steering	17
Fuel Tank	6	Transmission	12, 13
Lubricants		Rear Axle	1, 14
Engine Crankcase	6	Regulator - Generator	8
Transmission and Overdrive	12, 13	Rims	15
Rear Axle	14	Rings, Piston	3
Carburetor	6	Rods - Connecting	3
Caster	18	Shock Absorbers, Front & Rear	16
Choke, Automatic	6	Spark Plugs	9
Circuit Breakers, Fuses	11	Speedometer	10
Clearance, Ground	21	Springs - Front & Rear Suspension	17, 18
Clutch - Pedal Operated	12	Valve, Engine	5
Coil, Ignition	9	Stabilizer (Sway Bar) - Front & Rear	17, 18
Connecting Rods	3	Starting Motor	8
Cooling System	7	Steering	17, 18
Crankshaft	4	Suppression - Ignition, Radio	9
Cylinders and Cylinder Head	2	Suspension - Front & Rear	16, 17, 18
Distributor - Ignition	9	Switches	10
Electrical System	8, 9, 10, 11	Tailpipe	6
Engine		Thermostat, Cooling	7
Bore, Stroke, Displacement, Type	1, 2	Timing, Engine & Valve	4, 5, 9
Compression Ratio	1, 2	Tires	1, 15
Firing Order, Cylinder Numbering	2, 9	Toe in	18
General Information, H.P. & Torque	1, 2	Torque Converter	13
Lubrication	5, 6	Torque - Engine, Rated	1, 2
Exhaust System	6	Transmission - Types	1, 12, 13
Fan, Cooling	7	Automatic	1, 13
Filters - Engine Oil, Fuel System	6	Manual & Overdrive	12, 13
Frame	16	Ratios	12, 13
Front Suspension	16, 17	Tread	1, 23
Fuel, Fuel Pump, Fuel System	6	Turning Diameter	17
Fuel Injection	1, 6	Universal Joints, Propeller Shaft	14
Fuses, Circuit Breakers	11	Valves - Intake & Exhaust	4, 5
Generator and Regulator	8	Vibration Damper	4
Glass	21, 23, 25	Voltage Regulator	8
Headroom - Body	20	Water Pump	7
Heights - Car & Body	1, 20, 21	Weights - Shipping, Curb	26
Hood	25	Wheel Alignment	18
Horns	10	Wheelbase	1, 22
Horsepower - Brake, Rated, Taxable	1, 2	Wheels & Tires	15
Ignition System	9	Wheel Spindle	18
Inflation - Tires	15	Widths - Car & Body	1, 23
Instruments	6, 10	Windshield	21, 23, 25
Kingpin (Steering Axis)	18	Windshield Wiper	10



7

8

9

10



AMA Specifications – Passenger Car

Page 1

Data prepared and distributed by American automobile manufacturers, using uniform questionnaire form developed by car manufacturers under auspices of the Automobile Manufacturers Association.

MAKE OF CAR	CHEVROLET	MODEL YEAR	1959	DATE: ISSUED	7-15-58	REVISED	12-2-58
COMPANY	Chevrolet Motor Division, General Motors Corporation						
MODEL NAME	SYMBOL	MODEL NAME	SYMBOL				
Biscayne	1200	Station	1200(Brookwood)				
Bel Air	1600	Wagons	1600(Parkwood, Kingswood)				
Impala	1800		1800(Nomad)				

TABLE OF CONTENTS

General Specifications	1	Drive Units	12	Rear Suspension	18	Body & Car - General	25
Engine - Mechanical	2	Brakes	15	Body Dimensions	19	Weights	26
Electrical	8	Front Suspension & Steering	16	Station Wagon	24	Index	27

NOTES:

1. The specifications set forth herein are those in effect at the date of compilation and are subject to change without notice, UNLESS OTHERWISE INDICATED:
2. All specifications are standard for the models under which they are listed.
3. Specifications apply basically to 4-door sedan or equivalent. Body dimensions shown on pages 19-24 include other body models available.
4. All dimensions are nominal engineering dimensions.

GENERAL SPECIFICATIONS

MODEL	Additional Information Page No.:	1200-1600-1800 Series	
		283 cu.in. V-8 (Standard)	348 cu.in. V-8 (Optional)
Wheelbase (L-101)	22	119.0	
Tread	Front (W-101)	60.3	
	Rear (W-102)	59.3	
Maximum Overall Dimensions	Length (L-103)	210.9	
	Width (W-103)	79.9	
	Height (H-101)	56.0	
Transmission— (Specify trade name - opt., not available)	Manual	3-Speed (b)	3-Speed (c)
	Overdrive	Optional (h)	Not used
	Automatic	Powerglide, Turboglide optional (f)	
Axle ratio	Manual	3.55:1	3.36:1 (i)
	Overdrive	3.70:1	Not used
	Automatic	3.36:1	3.08:1 (j)
Tire size	15	7.50 x 14-4 ply (a)	
Engine	Type, no. cyl., valve arr.	90° V-8, OHV	
	Fuel system (Carb. or inj.)	Carburetor (g)	Carburetor
	Bore and stroke	3.875 x 3.000	4.125 x 3.25
	Piston displ., cu. in.	283	348
	Std. compression ratio	8.5:1 (d)	9.5:1 (e)
	Max. bhp at engine rpm	185 @ 4600	250 @ 4400
	Max. torque at rpm	275 @ 2400	355 @ 2800

(a) 8.00 x 14-4 ply on Convertible, Station Wagons, Sed. Del., Sed. Pickup. Rev. Form 1-58

(b) 4-speed optional with Fuel Injection

(c) 4-speed optional

9.5:1 with 4-barrel carburetor and Fuel Injection; 10.5:1 with F.I. and spec. cam.

(d) 11.0:1 with special cam and H D Powerglide; 11.25:1 with synchromesh and special cam.

(e) Turboglide NA with 4-bbl. carburetor and special cam; no auto. w/3x2 carbs. & spec. cam

(f) Fuel Injection available optionally

(g) NA with Fuel Injection.

(h) 3.55:1 rear axle used with 4-speed transmission

(i) 3.55:1 rear axle used with special camshaft engines

AMA Specifications — Passenger Car

Page 2

NAME OF CAR		CHEVROLET		MODEL YEAR	1959	DATE ISSUED	7-15-58	REVISED	11-25-58
				1200-1600-1800 Series					
MODEL		283 cu.in. V-8 (Standard)				348 cu.in. V-8 (Optional)			
ENGINE—GENERAL									
Type, no. cyls., valve arr.		90° V8, OHV							
Bore and stroke		3.875 x 3.000				4.125 x 3.25			
Piston displacement, cu. in.		283				348			
Bore spacing (C/L to C/L)		4.4				4.84			
No. system (front to rear)		L. Bank		1-3-5-7					
		R. Bank		2-4-6-8					
Firing order		1-8-4-3-6-5-7-2							
Compres. ratio (nominal)		Standard		8.5:1				9.5:1	
		Optional		9.5:1 (a)				11.0:1 (e)	
Cylinder Head Material		Standard		Cast alloy iron					
		Optional		None					
Cylinder Sleeve - Wet, dry, none		None							
Number of mounting points		Front		Two					
		Rear		One					
Taxable horsepower		48		54.5					
Published max. bhp at engine RPM*		Standard		185 @ 4600				250 @ 4400	
		Optional		(f)(f)	
Published max. torque* (lb. ft. @ RPM)		Standard		275 @ 2400				355 @ 2800	
		Optional		(f) (f)	
Recommended fuel regular - premium		Standard		Regular				Premium	
		Optional		Premium				Premium	
Recommended idle speed (neutral)		3-speed, 475 RPM in Neutral; Automatic, 450 RPM in Drive							

ENGINE—PISTONS

Material		Cast aluminum alloy							
Description and finish		Flat head, slipper skirt autothermic (b)(d)				Peak roof, slipper skirt autothermic (c)			
		Weight (piston only) oz.		20.40				26.72 (g)	

* Max. bhp (brake horsepower) and max. torque corrected as defined by SAE Engine Test Code.

(Continued)

Rev. Form 6-57

- (a) 10.5:1 with Fuel Injection and special cam.
- (b) With machined relief for valve clearance.
- (c) Half flat having machined relief for valve clearance and half slanted downward 16° with special cam.
- (d) Fuel Injection with special cam - domed piston having machined relief.
- (e) With special cam and H D Powerglide; 11.25:1 with synchromesh and special cam.
- (f) See Page 1 Supplement
- (g) 20.20 oz. with special cam.

AMA Specifications -- Passenger Car

Supplement to Page 2

MAKE OF CAR CHEVROLET MODEL YEAR 1959 DATE ISSUED 7-15-58 REVISED 11-25-58

SUPPLEMENTARY INFORMATION

MODEL 1200-1600-1800 Series

<u>Max BHP @ Engine RPM</u>	<u>283 cu. in. V-8</u>	<u>Max. Torque @ RPM</u>
<u>4-barrel Carburetor</u> 230 @ 4800		300 @ 3000
<u>Ramjet Fuel Injection</u> 250 @ 5000		305 @ 3800
<u>Ramjet Fuel Injection (with special camshaft)</u> 290 @ 6200		290 @ 4400
	<u>348 cu. in. V-8</u>	
<u>4-barrel Carburetor (with special camshaft and H D Powerglide)</u> 305 @ 5600		350 @ 3600
<u>3 x 2-barrel Carburetor</u> 280 @ 4800		355 @ 3200
<u>3 x 2-barrel Carburetor (with special camshaft and synchromesh)</u> 355 @ 5800		362 @ 3600
<u>4-barrel Carburetor (with special camshaft and synchromesh)</u> 320 @ 5600		358 @ 3600

AMA Specifications - Passenger Car

MAKE OF CAR CHEVROLET MODEL YEAR 1959 DATE ISSUED 7-15-58 REVISED 11-30-59
 1200-1600-1800 Series

MODEL	283 cu.in. V-8 (Standard)	348 cu.in. V-8 (Optional)		
ENGINE PISTONS (Cont.)				
Clearance (limits)	Top land	.035-.043	.0325-.0367	
	Skirt	Top	.0006-.0010 (a)	.0006-.0010 (c)
		Bottom	NA	NA
Ring groove depth	No. 1 ring	.2153-.2218	.2283-.2334	
	No. 2 ring	.2153-.2218	.2283-.2334	
	No. 3 ring	.2093-.2158	.2183-.2234	
	No. 4 ring	None		

ENGINE-RINGS

Function (top to bottom)	No. 1, oil or comp.	Compression	
	No. 2, oil or comp.	Compression	
	No. 3, oil or comp.	Oil control	
	No. 4, oil or comp.	None	
Compression	Description - material, type, coating, etc.	Upper: cast alloy iron, plain, chrome plated. Lower: cast alloy iron, plain, wear resistant coating	
	Width	.0775-.0780	.0770-.0780
	Gap	.010 - .020	.015 - .025
Expanders	Description - material, type, coating, etc.	Rails: steel, chrome plate O.D. Spacer: stainless steel	
	Width	.224-.231 (d)	.224-.231 (d)
	Gap	.015-.055 (e)	.015-.055 (e)
		In oil ring assembly	

ENGINE-PISTON PINS

Material		Chromium steel	
Length		2.990-3.010	3.250-3.270
Diameter		.9270-.9273	.9895-.9898
Type	Locked in rod, in piston, floating, etc.	Pressed in rod	
	Bushing	In rod or piston	None
		Material	None
Clearance	In piston	.00015-.00025	
	In rod	None	
Direction & amount offset in piston		Major thrust side - .060	

ENGINE-CONNECTING RODS

Material		Drop forged steel	
Weight (oz.)		19.02	19.20
Length (center to center)		5.699-5.701	6.134-6.136
Bearing	Material & Type		Steel backed babbitt (b)
	Overall length	.817	.867
	Clearance (limits)	.0007-.0027	.007-.0027
	End play	.008-.014	.008-.014

- (a) Measured 2.44 from top of piston
- (b) Steel backed aluminum alloy matrix with a thin lead alloy overplate with special cam and Synchromesh transmission
- (c) Measured 2.94 from top of piston
- (d) .1355-.1865 with special cam

AMA Specifications – Passenger Car

MAKE OF CAR	CHEVROLET	MODEL YEAR	1959	
		DATE ISSUED	7-15-58	
		REVISED	1-30-59	
MODEL	283 cu.in. V-8 (Standard)	348 cu.in. V-8 (Optional)		
ENGINE—CRANKSHAFT				
Material	Forged steel			
Vibration damper type	Oscillating (rubber floating)			
End thrust taken by bearing (No.)	5			
Crankshaft end play	.002-.006	.003-.007		
Main bearing	Material & type	Steel backed babbitt, removable (a)		
	Clearance	.0008-.0034	.0006-.0032	
	Journal dia. and bearing overall length	No. 1	2.2983 x .762	2.4985 x 1.002
		No. 2	2.2983 x .762	2.4985 x 1.002
		No. 3	2.2983 x .762	2.4985 x 1.002
		No. 4	2.2983 x .762	2.4985 x 1.002
		No. 5	2.2983 x 1.169	2.4985 x 1.262
		No. 6	None	None
No. 7		None	None	
Dir. & amt. cyl. offset	None		None	
Crankpin journal diameter	1.999-2.000	2.199-2.200		

ENGINE—CAMSHAFT

Location	Above crankshaft		
Material	Cast alloy iron		
Bearings	Material	Steel backed babbitt	
	Number	5	
Type of drive	Gear or chain	Chain	
	Crankshaft gear or sprocket material	Steel	
	Camshaft gear or sprocket material	Cast alloy iron	
	Timing chain	No. of links	46
Width		.875	.875
Pitch		.500	.500

ENGINE—VALVE SYSTEM

Hydraulic lifters (Std, opt, NA)	Standard (b)		
Special provision for valve rotation (intake, exhaust)	None		
Rocker ratio	1.5:1	1.75:1	
Operating tappet clearance (indicate hot or cold)	Intake	Zero (c)	
	Exhaust	Zero (c)	
Timing marks on fly-wheel, damper, other	Damper		

(Continued)

Rev. Form 6-57

- (a) With special camshaft, and Synchromesh transmission #1 thru 4-steel backed aluminum alloy matrix with a thin lead alloy overplate
- (b) Mechanical valve lifters standard with special camshaft
- (c) Valve lash (hot) with special camshaft - .012" intake, .018" exhaust

AMA Specifications – Passenger Car

MAKE OF CAR CHEVROLET MODEL YEAR 1959 DATE ISSUED 7-15-58 REVISED 1-30-59
 1200-1600-1800 Series

MODEL	283 cu. in. V-8 (Std.)	348 cu. in. V-8 (Opt.)	
	Reg. Cam	Special Cam	
	All Trans.	Reg. Trans.	H.D. PG

ENGINE—VALVE SYSTEM (cont.)

Timing			Spec. Cam		Reg. Cam		
					All Trans.	Reg. Trans.	H.D. PG
Timing	Intake	Opens (°BTC)	12°30'	35°	18°30'	35°	33°
		Closes (°ABC)	57°30'	72°	67°30'	72°	74°
		Duration - deg.	250°	287°	266°	287°	287°
	Exhaust	Opens (°BSC)	54°30'	76°	68°30'	76°	88°
		Closes (°ATC)	15°30'	31°	25°30'	31°	19°
		Duration - deg.	250°	287°	274°	287°	287°
Valve opening overlap		28°	66°	44°	66°	52°	

Material		High Alloy Steel (864 5)(d)					
Overall length		4.902-4.922	4.869-4.889	5.095-5.115			
Actual overall head dia.		1.715-1.725		1.935-1.945			
Angle of seat		46° in head					
Seat insert material		None					
Stem diameter		.3415-.3422		.3715-.3722			
Stem to guide clearance		.0010-.0027		.0010-.0027			
Intake	Lift	.3987	.3938	.4005	.4058	.4076	
	Outer spring press. and length	Valve closed (lb. @ in.)	69-79 @ 1.696		78-86 @ 1.626 (a)		
		Valve open (lb. @ in.)	159-169 @ 1.306		184-196 @ 1.230 (b)		
	Inner spring press. and length	Valve closed (lb. @ in.)	None		20-24 @ 1.488 (c)		
		Valve open (lb. @ in.)	None		55-61 @ 1.06 (c)		

Material		High Alloy Steel (21-4N)(d)					
Overall length		4.913-4.933	4.890-4.910	5.105-5.125			
Actual overall head dia.		1.495-1.505		1.655-1.665			
Angle of seat		46° in head					
Seat insert material		None					
Stem diameter		.3410-.3417		.3710-.3717			
Stem to guide clearance		.0015-.0032		.0025-.0042			
Exhaust	Lift	.3987	.3998	.4119	.4120	.4139	
	Outer spring press. and length	Valve closed (lb. @ in.)	69-79 @ 1.696		78-86 @ 1.626 (a)		
		Valve open (lb. @ in.)	159-169 @ 1.306		184-196 @ 1.230 (b)		
	Inner spring press. and length	Valve closed (lb. @ in.)	None		20-24 @ 1.488 (c)		
		Valve open (lb. @ in.)	None		55-61 @ 1.06 (c)		

ENGINE—LUBRICATION SYSTEM

Type of lubrication (splash, pressure, nozzle)	Main bearings	Pressure
	Connecting rods	Pressure
	Piston pins	Splash
	Camshaft bearings	Pressure
	Tappets	Pressure
	Timing gear or chain	Nozzle sprayed
	Cylinder walls	Pressure, jet cross sprayed

(a) 69-79 @ 1.696 with special cam and synchromesh transmission. (Continued) Rev. Form 6-57
 (b) 159-169 @ 1.306 with special cam and synchromesh transmission.
 (c) With special cam and synchromesh transmission
 (d) Aluminized valve faces on 348 engines with spec. cam and synchromesh transmission.

AMA Specifications – Passenger Car

Page 6

NAME OF CAR	CHEVROLET	MODEL YEAR	1959	DATE ISSUED	7-15-58	REVISED	11-25-58
			1200-1600-1800 Series				
MODEL	283 cu.in. V-8 (Standard)					348 cu.in. V-8 (Optional)	
ENGINE—LUBRICATION SYSTEM (cont.)							
Oil pump type							Gear
Normal oil pressure (lb. @ engine rpm)							35 psi @ 2000 RPM
Oil pressure sending unit (elect. or mech.)							Electrical
Type oil intake (floating, stationary)							Stationary
Oil filter system (full flow, partial, other)		Full flow (a)					Full flow (b)
Filter replacement (element, complete)							Element
Capacity of crankcase, less filter-refill (qt.)							4
Oil grade recommended (SAE viscosity and temperature range)							32°F and above - SAE 20W, SAE 20 or SAE 10W-30 0°F and above - SAE 10W or SAE 10W-30 Below 0°F - SAE 5W or SAE 5W-20
Engine Service Requirement (MM, MS, etc.)							MS or DG

ENGINE—EXHAUST SYSTEM

Type (single, single with cross-over, dual, other)	Single with cross-over pipe (c)	Dual
Muffler No. & type (reverse flow, straight thru, separate resonator)	One-reverse flow	Two, reverse flow with resonators
Exhaust pipe dia. (O.D. & wall thickness)	Branch	NA
	Main	NA
pipe diameter (O.D. & wall thickness)	2.0 x .0625	2.0 x .0625 (h)
	1.81 x .0598	1.875 x .0598 (h)

ENGINE—FUEL SYSTEM

(See Supplement to Page 6 for Details of Fuel Injection, Supercharger, etc. if used)

Induction type: Carburetor, fuel injection, supercharger.	Carburetor (e)	Carburetor
Fuel Tank	Capacity (gals.)	20 (d)
	Filler location	Concealed behind hinged rear license plate (f)
Fuel Pump	Type (elec. or mech.)	Mechanical
	Locations	Lower right front of engine
	Pressure range	5.25-6.50 psi
Vacuum booster (std., optional, none)		None
Fuel Filter	Type and	Strainer in gasoline tank and sintered bronze filter in carburetor inlet
	Locations	
Carburetor	Make & Model No.	(g)
	Number & Type	(g)
	Barrel size	1.4375
	Choke type	Automatic
	Intake manifold heat control (exhaust or water)	Exhaust
	Air enr. type	Dry
	Standard Optional	None

- (a) Standard equipment with Fuel Injection
- (b) Mandatory equipment with special cam
- (c) Deutz-Dieselmotoren standard with Fuel Injection; optional on others—have resonators
- (d) 17 gal. on 6-pass. Station Wagons & Sedan Delivery, 18 gal. on 9-pass. Station Wagon
- (e) Fuel Injection optional
- (f) In left rear quarter panel on Station Wagons and Sedan Delivery
- (g) See supplement
- (h) 2.5" OD exhaust pipe and 2.0" OD tail pipe with special cam and synchromesh transmission

Rev. Form 1-58

AMA Specifications -- Passenger Car

Supplement to Page 6

MAKE OF CAR CHEVROLET MODEL YEAR 1959 DATE ISSUED 7-15-58 REVISED 10-16-58

SUPPLEMENTARY INFORMATION

MODEL 1200-1600-1800 Series V-8

Engine Fuel System - Fuel Injection

Injection System	Make	Rochester Products
	Model	7017200 (b)
	Type	Constant flow
Fuel Recommended		Premium
Fuel Pump	Type	Mechanical
	Location	Lower right front corner of engine
	Pressure range	5.25-6.50 psi
Auxiliary Fuel Filter	Type	Paper filter
	Location	Bracketed to engine adapter on right, rear of center
Inlet Manifold Adapter-Material		Cast aluminum
Inlet Manifold - Material		Cast aluminum
Air Induction (a)	Air Cleaner Type	Dry (paper element)
	Air Meter Location	Left side of engine
	Plenum Chamber	Integral with inlet manifold
	Ram Pipes	Eight, integral with inlet manifold
	Ram Pipe Length	12 inches
Fuel Induction		Metered as function of air flow
Air/Fuel Ratio Control	Type	Vacuum sensitive diaphragm
	Location	On fuel meter
Fuel Meter Pump	Type	Gear
	Location	In fuel meter assembly
	Drive	Gear driven by flexible shaft from distributor
	Pressure (max.)	300 psi
Injection Nozzles	No. Used	Eight
	Material	Brass
	Location	Mounted on inlet manifold above intake ports
	Orifice Size, Fuel	.0118
Automatic Enrichment	Insulation	Bakelite blocks
	Type	Electric, time-temperature
	Location	On air meter assembly
	Current Draw	1 amp. @ 70°
	Fast Idle Cam	Yes

- (a) Air intake ducts which channel outside air to the engine compartment are furnished with Fuel Injection.
- (b) 7017250 with special camshaft.

AMA Specifications -- Passenger Car

Supplement to Page 6

MAKE OF CAR CHEVROLET MODEL YEAR 1959 DATE ISSUED 7-15-58 REVISED 1-1-30-59
 1200-1600-1800 Series V-8

SUPPLEMENTARY INFORMATION

MODEL 1200-1600-1800 Series V-8

Engine Fuel System - cont'd.

<u>Type</u>	<u>Transmission</u>	<u>283 Cubic Inch</u>	
		<u>Make</u>	<u>Model</u>
2-bbl, D.D.	3-Speed Automatic	Rochester	7013007
		Rochester	7013008
4-bbl, D.D.	3-Speed Automatic	Carter	3756676
		Rochester	7013004
<u>348 Cubic Inch</u>			
4-bbl, D.D.	3 or 4-Speed Automatic	Carter	3756677
		Carter or Rochester	3756678 7013006
		Carter	3764593
4-bbl, D.D. (spec. cam)	3 or 4-Speed H.D. Powerglide	Carter	3764593
3x2 bbl, D.D.	3 or 4-Speed Automatic	Rochester	7013015 (front) (a) 7013020 (center) (a) 7013017 (rear) (a)
		Rochester	7013016 (center)
3x2 bbl, D.D.	3 or 4-Speed	Rochester	7013973 (front) 7013974 (center) 7013975 (rear)

(a) Also used with automatic transmissions.

AMA Specifications – Passenger Car

NAME OF CAR		CHEVROLET		MODEL YEAR	1959	DATE ISSUED	7-15-58	REVISED	11-25-58	
MODEL		283 cu.in. V-8 (Standard)			348 cu.in. V-8 (Optional)					
ENGINE-COOLING SYSTEM										
Type (pressure system, atmospheric, other)		Pressure system								
Radiator cap relief valve pressure		13 psi								
Circulation thermostat	Type (choke, bypass)	Choke			Bypass					
	Starts to open at (°F)	167-172°F								
Water pump	Type (centrifugal, other)	Centrifugal								
	Number of pumps	One								
	Drive (V-belt, other)	V-belt								
Bearing type		Permanently lubricated double row ball								
By-pass recirculation type (internal, external)		Internal			External					
Radiator core type (cellular, tube and fin, other)		Tube on center								
Cooling system capacity	With heater (qt.)	18.5*			22.0					
	Without heater (qt.)	17.5*			21.0					
	Opt. equipment-specify (qt.)	None								
Water jackets full length of cylinder (yes, no)		Yes								
Water oil around cylinder (yes, no)		Yes								
Radiator hose	Lower	Number and type (molded, straight)	One, molded							
		Inside diameter	1.75							
	Upper	Number and type (molded, straight)	One, molded							
		Inside diameter	1.50							
	By-pass	Number and type (molded, straight)	None			One, molded				
		Inside diameter	None			.610				
Fan	Number of blades & Spacing		4, staggered							
	Diameter		17.62"							
	Ratio-fan to crankshaft rev.		.949:1							
	Fan cutout type		(a)							
	Bearing type		Permanently lubricated double row ball							
*Drive belts (indicate belt used by letter)	Fan		A			C				
	Generator		A			C				
	Water Pump		A			C				
	Power Steering		B			B				
	Air Conditioning		B			B				
	Air Suspension		B			B				

Rev. Form 1-58

* Drive Belt Dimensions	A	C	B
Angle of V	37-44°	37-44°	37-44°
Nominal length (SAE)	54.12(b)	57.00 (b)	56.00 (b)
Width	.380/ .005	.380/ .005	.380/ .005

- (a) Viscous coupling, 5-blade, 18" fan used with air conditioning, fan speed limited to 3100 RPM.
- (b) Pitch length.
- (c) With Speed transmission.

AMA Specifications - Passenger Car

Page 8

MAKE OF CAR	CHEVROLET	MODEL YEAR	1959	DATE ISSUED	7-15-58	REVISED	1-30-59	
		1200-1600-1800 Series						
MODEL	283 cu.in. V-8 (Standard)	348 cu.in. V-8 (Optional)						
ELECTRICAL-SUPPLY SYSTEM								
Battery	Make and Model	1980458	Delco-Remy	198Q558				
	Voltage Rts. & Total Plates	12 volt, 54 plate			12 volt, 66 plate			
	SAE Designation & Amp Hr. Rtg.	2 SLR, 53 amp.hr. @ 20 hr. rate			61 amp.hr @ 20 hr. rate			
	Location	Engine compartment, right front						
	Terminal grounded	Negative						
Generator	Make	Delco-Remy						
	Model	1102097 (a)						
	Type	Two brush, shunt wound						
	Ratio—Gen. to Cr/s rev.	2.3:1 (b)						
	Gen. cut-in—engine rpm	510						
Regulator	Make	Delco-Remy						
	Model	1119001			1119234			
	Type	Vibrator						
	Cutout relay	Closing voltage @ generator rpm	11.8-13.5 @ 1300					
		Reverse current to open	N.A.					
	Regulated	Voltage	13.8-14.8					
		Current	27-33					
	Voltage test conditions	Temperature	Operating					
Load		8-10 amperes						
Other		None						

ELECTRICAL-STARTING SYSTEM

Starting motor	Make	Delco-Remy					
	Model	1107664 (c)			1107688 (d)		
	Rotation (drive end view)	Clockwise					
	Engine cranking speed	N.A.					
	Test conditions	Engine at operating temperature					
	Lock test	Amps	N.A.		N.A.		
		Volts	N.A.		N.A.		
		Torque (lb. ft.)	N.A.		N.A.		
	No load test	Amps	49-76		65-100		
		Volts	10.6		10.6		
RPM (min.)		6200-9400		3600			
	Switch (solenoid, manual)	Positive Shift	Solenoid				
Motor control	Starting procedure	Place shift lever in neutral and depress clutch (e) Press accelerator to floor once to set automatic choke, then release. Turn ignition key to extreme right position to start engine.					

- (a) 1102059 with special cam
- (b) 1.66:1 with special cam
- (c) 1107694 with Turboglide
- (d) 1107687 with Turboglide;
- (e) For automatic transmission, place selector lever in "P" (Park) or "N" (Neutral) position.

Rev. Form 1-58

AMA Specifications - Passenger Car

Page 9

MAKE OF CAR CHEVROLET MODEL YEAR 1959 DATE ISSUED 7-15-58 REVISED 1-30-59
 1200-1600-1800 Series

MODEL 283 cu.in. V-8 (Standard) 348 cu.in. V-8 (Optional)
ELECTRICAL-STARTING SYSTEM (cont.)

Motor drive	Engagement type		Positive shift solenoid
	Pinion meshes (front, rear)		Front
	Number of teeth	Pinion	9
		Flywheel	168
	Flywheel tooth face width		.4135 (a)

ELECTRICAL-IGNITION SYSTEM

Coil	Make		Delco-Remy	
	Model		1115115 (b)	1115083 (c)
	Amps	Engine stopped	4.0	
		Engine idling	1.8	
Distributor	Make		Delco-Remy	
	Model		1110947 (d)	1110948 (k)
	Centrifugal adv. in crankshaft degrees @ engine rpm	Start (rpm)	600 (h)	700 (l)
		intermediate points deg. @ rpm	12@ 1500 (h)(i)	11° @ 1600 (l)
		Max deg. @ rpm	28@ 3750 (h)(i)	24@ 4600 (l)
	Vacuum adv. in crankshaft degrees @ in. Hg.	Start (in. Hg)	0@ 8 (j)	0@ 8 (f)
		Intermediate points, deg. @ in. Hg.	N.A. (f)	N.A. (f)
		Max. deg. in. Hg.	15@ 15.5 (j)	15@ 15.5 (f)
	Breaker gap (in.)		.016-.021	
	Cam angle (deg.)		26-33	
Breaker arm tension (oz.)		19-23		
Timing	Crankshaft deg. @ rpm.		4 BTC (g)	
	Mark location		Vibration damper	
	Cylinder numbering system (see page 2)		Left bank 1-3-5-7 Right bank 2-4-6-8	
	Firing order (see page 2)		1-8-4-3-6-5-7-2	
Spark Plug	Make and model		AC-44 (e)	
	Thread (mm)		14	
	Tightening torque (lb. ft.)		25	
	Gap		.035	
Cable	Conductor type		Linen core impregnated with electrical conducting material	
	Insulation type		Rubber with neoprene jacket	
	Spark plug protector		Hypalon jacket	

ELECTRICAL-SUPPRESSION

Description	Non-metallic high tension cable
-------------	---------------------------------

- | | |
|--|---|
| <ul style="list-style-type: none"> (a) .3435 with Turboglide transmission (b) 1115083 with Fuel Injection (c) 1115111 with 3x2 carburetors & 4-bbl. HD PG (d) 1115114 with special cam & syn. trans. (e) 1110946 with 4-barrel carburetor; (f) 1110947 with Fuel Injection & special cam (g) 1110948 with Fuel Injection (h) 313 engine AC-44N | <ul style="list-style-type: none"> (i) No vacuum advance with special cam & syn. trans. (j) 14° BTC with Fuel Injection and spec. cam (k) 0 @ 1000, 5 @ 1500 and 22@ 6000 w/F.I. & spec. cam (l) 14@ 1500 and 28@ 3700 for 4-barrel and Fuel Inj. (m) 0@ 5 and 24@ 13.5 for Fuel Injection. (n) 1110919 with special camshaft and synchromesh (o) 0@ 600, 15@ 1550 and 28@ 5000 with special cam and synchromesh transmission. |
|--|---|

AMA Specifications - Passenger Car

MAKE OF CAR CHEVROLET **MODEL YEAR** 1959 **DATE ISSUED** 7-15-58 **REVISED** 10-16-58
 1200-1600-1800 Series
MODEL 283 cu.in. V-8 (Standard) 348 cu.in. V-8 (Optional)

ELECTRICAL-INSTRUMENTS AND SWITCHES

Speed-ometer	Make	AC
	Trip odometer (yes, no)	No
Charge indicator-type		Tell-tale light
Temperature indicator-type		Gauge
Oil pressure indicator-type		Tell-tale light
Fuel indicator-type		Gauge
Other		Parking brake tell-tale light (a)
Ignition switch	Identify positions in order and circuits controlled	53° Counter clockwise from vertical - "Lock" 13° Counter clockwise from vertical - "Off", unlocked 27° Clockwise from vertical - "On" ign., batt., accessories 57° Clockwise from vertical - "Start", ign., batt., starter spring return to "On" position.
	Provision for illumination	Lamp in lock housing
	Location	On instrument panel right of steering column
Main lighting switch	Identify positions and lights controlled	Depressed - Off 1st notch - Instrument panel, parking, tail and license lights 2nd notch - Instrument panel, head, tail and license lights Rotate knob clockwise to dim and turn off instrument panel lights Rotate knob counter clockwise to turn on and brighten instru. panel lights and turn on dome light.
	Locations and lamps controlled	Toe panel ----- Headlight dimmer Glove compartment ----- Glove comp. lamp (c) Front door hinge pillar ----- Dome lamp (d) Under instrument panel ----- Turn signal lamps Under instrument panel ----- Stop lamps Steering mast jacket ----- Back up lamps (a)
Other light switches	Locations and devices controlled	Accelerator linkage ----- Overdrive kick down (h) Instrument panel ----- Heater blower (e) Door or qtr. trim panels ----- Power windows (f) Front seat lwr. panel, lh ----- Power seat (f) Instru. panel, center ----- Radio (e) Instru. panel, left ----- W/s wiper, back window (g)
	Make	Delco
Windshield wiper	Type	Electric, single speed (b)
	Vacuum booster provision	None
	Washer provision	Fact Opt. Acc. (pushbutton), or dealer inst. acc. (pushbutton or foot op) (b)
Horn	Type	Vibrator
	Number used	2
	Amp draw (each)	8.0-11.0 @ 12.5 volts

Rev. Form 6-57

- (a) Standard equipment on 1800 Series, dealer installed accessory on all others.
- (b) Two-speed (electric) with pushbutton washers avail. as Fact. Opt. Acc.
- (c) Dealer installed accessory on 1200 Series, std. equip. on all others.
- (d) Except 1200 Series
Available as Factory Optional Accessory or dealer installed accessory
- (e) Available as Regular Production Option on 1600-1800 Series
- (g) Power operated tailgate window std. equip. on 9-pass. wagon (1645) Reg. Prod. Opt. on 1635 - 1835 wagons.
- (h) Avail. as Reg. Prod. Option on 283 cu. in. V-8 only.

AMA Specifications - Passenger Car

MAKE OF CAR CHEVROLET MODEL YEAR 1959 DATE ISSUED 7-15-58 REVISED 10-16-58
 MODEL 1200-1600-1800 Series V-8

ELECTRICAL-LAMP BULBS

Give quantity used and trade number, e.g., Headlamp 2-5400 S, dual headlight 2-4001, 2-4002.
 Indicate accessories which are not standard equipment by an asterisk following the numbers.

Headlamps & arrangement	Horizontal 2-4001 (inner) 2-4002 (outer)
Headlamp beam indicator	1-53
Parking light	2-1034 (4 cp filaments)
Tail light	4-1034 (4 cp filaments)
Stop light	4-32 cp filaments of tail light bulbs.
Direction signal	Front 2-32 cp filaments of parking light bulbs
	Rear 4-32 cp filaments of tail light bulbs.
	Indicator 2-57
License plate light	Stations, sed, del, sed pickup: 1-67, balance of models: 2-67
Instrument light	1200-1600 series: 4-57, 1800 series: 5-57
Ignition lock light	1-53
Back up light	2-1073 (std. equip on 1800 series, acc. on 1200-1600 series)
Dome light	Sport coupe, sport sedan: 2-90, convt. 2-89 balance of models: 1-1004
Clock light	1-57 (std. equip. on 1800 series, acc. on 1200-1600 series)
Radio light	1-1891*
Glove compartment light	1-57 (std. equip. on 1600-1800 series, acc. on 1200 series)
Charge indicator	1-57
Oil press ind.	1-57
Third seat courtesy	1-89 (9-passenger wagon only)
Park brake alarm	1-257 (std. equip on 1800 series, acc. on 1200-1600 series)
Heater	1-53*
Aid cond.	1-53*

ELECTRICAL-FUSE & CIRCUIT BREAKER DATA

Use trade number of fuse, e.g., SFE-10. Indicate circuit breaker by ampere capacity suffixed by letters "C.B." e.g., 30 C.B. Where fuse or circuit breaker protects multiple circuits indicate first use by a letter and repeat the same letter for all units protected by the same fuse or circuit breaker, e.g., Parking lights SFE-10 (a), Direction indicator same as (a).

Headlamp	15CB (a)
Headlamp beam indicator	(a)
Parking light	(a)
Tail light	3 AG/AGC-15 amp (b)
Stop light	(b)
Direction indicator	Flasher
License plate light	(b)
Instrument light	3 AG/AGC-3 amp (c)
Ignition light	(c)
Back up light	3 AG/AGC-10 amp (d)
Dome light	(b)
Clock	(d)
Clock light	(c)
Radio	Light (all):(c), receiver-manual & p. button: 3 AG/AGC 4 amp., sig. seek: 3AG/AGC7.5
Glove compartment light	(b)
Cigarette lighter	Not fused
Park brake alarm	(d)
Heater	Light: (c), blower: 3 AG/AGC 10 amp
Cond.	Light: (c), blower: SAE 20 amp
Drive	SAE 9 amp

AMA Specifications – Passenger Car

MAKE OF CAR CHEVROLET MODEL YEAR 1959 DATE ISSUED 7-15-58 REVISED 1-30-59

	1200-1600-1800 Series	
MODEL	283 cu. in. V-8 (Standard)	348 cu. in. V-8 (Optional)
DRIVE UNITS—CLUTCH (Manual Transmission)		

Make & type	Semi-centrifugal	
Type pressure plate springs	Diaphragm	
Total plate pressure (lb.)	1475-1625 (a)	1775-1875
No. of clutch driven discs	One	
Clutch facing	Material	Woven (g)
	Outside & inside dia.	10.0 x 6.0 (b)(d)
	Total eff. area (sq.in.)	100.53 (c)
	Thickness	.135
	Engagement cushioning method	Springs
Release bearing	Type & method of lubrication	Ball bearing, sealed
Torsional damping	Methods: springs, friction material	Springs

DRIVE UNITS—TRANSMISSIONS

Manual (std. or opt.)	Standard (e)	
Manual with overdrive (std. or opt.)	Optional (h)	NA
Automatic (std. or opt.)	Powerglide and Turboglide (optional)(f)	

DRIVE UNITS—MANUAL TRANSMISSION

Number of forward speeds	Three	Four (e)	Three	
Transmission ratios	In first	2.47:1	2.20:1	
	In second	1.53:1	1.66:1	
	In third	1.00:1	1.31:1	
	In fourth	None	1.00:1	
	In reverse	2.80:1	2.26:1	
Synchronous meshing, specify gears	2nd & 3rd	1st thru 4th	2nd & 3rd	
Lubricant	Capacity (pt.)	2.0	2.0	
	Type recommended	A-9 mineral oil		
	SAE viscosity number	Summer	SAE-90	
		Winter	SAE-90	
	Extreme cold	SAE-80		

- (a) 1575-1725 with Overdrive, 4-barrel carburetor and Fuel Injection.
- (b) ID 6.5" on Overdrive, 4-barrel carburetor and Fuel Injection.
- (c) 90.72" on Overdrive and Fuel Injection.
- (d) Same clutch used with 3 and 4-speed transmissions.
- (e) 4-speed close ratio available only with Fuel Injection and 348 cu. in. engines.
- (f) Turboglide NA with special camshaft; Powerglide NA with 3X2 carbs. and special camshaft.
- (g) Asbestos composition.
- (h) Available with only 2 and 4-barrel carburetors.

AMA Specifications - Passenger Car

MAKE OF CAR CHEVROLET MODEL YEAR 1959 DATE ISSUED 7-15-58 REVISED 11-10-58
 MODEL _____ 1200-1600-1800 Series _____
 _____ 283 cu.in. V-8 _____ 348 cu.in. V-8

DRIVE UNITS—MANUAL TRANSMISSION WITH OVERDRIVE

For transmission data see manual transmission section

Overdrive	Type (planetary or other)		Planetary	NA	
	Manual lockout (yes, no)		Yes	-	
	Downshift accelerator control (yes, no)		Yes	-	
	Minimum cut-in speed		27	-	
	Gear ratio		0.70:1	-	
	Lu- bri- cant	Capacity (Overdrive only)		1 pint	-
		Separate filler (yes, no)		No	-
		Type recommended		A-9 mineral oil	-
		SAE vis- cosity number	Summer	SAE-90	-
			Winter	SAE-90	-
Ext. cold	SAE-80		-		

DRIVE UNITS—AUTOMATIC TRANSMISSION

Trade name	Powerslide	Turboglide	Powerslide	Turboglide
Type describe	Torque converter with planetary gears			
Method of Selection (Lever, Push Button or other)	Lever			
Selector Pattern	P-R-N-D-L	P-R-N-D-Gr	P-R-N-D-L	P-R-N-D-Gr
1st gear ratios Selector Pattern and indicate which are used in each selector position	Drive 1.82& 1.0:1(d) Low 1.82 Rev. 1.82	Drive 1.63:1 2.67:1 Grade Retarder 2.67:1	Drive 1.82& 1.0:1(d) Low 1.82 Rev. 1.82	Drive 1.63:1 2.67:1 Grade Retarder 2.67:1
Max. upshift speeds—drive range	55	(b)	55	(b)
Max. kickdown speeds—drive range	50	(b)	50	(b)
Torque converter	Number of elements		3	5
	Max. ratio at stall at engine rpm		2.1:1	(a)
	Type of cooling (air, water)		Water	
Lubricant	Capacity—refill (qt.)		9	4
	Type recommended		Type A, Suffix "A"	
Special transmission features		(c)		(c)

Rev. Form 6-57

- (a) 3.8:1 (low stator); 4.2:1 (high stator)
- (b) Stator may be switched from low to high angle at any vehicle speed. With the stator vanes in either angle, multiplication ceases at approximately 60 mph.
- (c) Grade Retarder provides engine braking. Triple turbine torque converter with variable pitch stator.
- (d) Total transmission torque multiplication - 3.82:1.

AMA Specifications – Passenger Car

MAKE OF CAR CHEVROLET MODEL YEAR 1959 DATE ISSUED 7-15-58 REVISED 12-2-58
 1200-1600-1800 Series

MODEL _____ 283 cu.in. V-8 _____ 348 cu.in. V-8 _____
 (Standard) (Optional)

DRIVE UNITS—PROPELLER SHAFT

Number used		2	
Type (exposed, torque tube)		Exposed	
Outer diameter x length* x wall thickness	Manual transmission (3-speed)	Front - 2.003 x 30.12 x .097 (a) Rear - 2.003 x 35.00 x .097	
	Overdrive transmission	Front - 2.003 x 24.97 x .097 Rear - 2.003 x 35.00 x .097	
	Automatic transmission (Powerglide)	Front - 2.003 x 24.03 x .097 (b) Rear - 2.003 x 35.00 x .097	
Inter-mediate bearing	Type (plain, anti-friction)	Anti-friction	
	Lubrication (fitting, prepack)	Prepack	
Make		Own	
Number used		3	
Universal joints	Type (ball and trunnion, cross, other)	Yoke and spider (trunnion)	
	Bearing	Type (plain, anti-friction)	Anti-friction
		Lubric. (fitting, prepack)	Prepack
Torque taken through (torque tube arms, springs)		Upper and lower control arms	
Torque taken through (torque tube or arms, springs)		Upper and lower control arms	

DRIVE UNITS—REAR AXLE

Description - (incl. limited slip differential)		Standard axle - Semi-floating, overhung pinion gear Optional "Positraction" axle-Semi-floating, overhung pinion gear. Spicer limited slip with dual 4 disc clutches applied by reaction torque through the differential side gears	
Drive Pinion Offset		1.5	
No. of differential pinions		2 (c)	
Gear ratio and No. of teeth	Automatic transmission	3.36:1, 11-37	3.08:1, 12-37 (d)
	Overdrive trans.	3.70:1, 10-37	Overdrive not used
	Manual transmission	3.55:1, 9-32	3.36:1, 11-37 (e)
Ring gear pitch diameter & O.D.		8.375 p.d. & p.d.	
Pinion adjustment (shim, other)		Shim	
Pinion bearing adj. (shim, other)		None	
Wheel bearing type		Ball	
Capacity (gr.)		4	
Type recommended		A-9 hypoid	
Lubricant	SAE viscosity number	SAE-90	
	Summer	SAE-90	
	Winter	SAE-90	
Extreme cold		SAE-90	

*Center to center of universal joints, or to centerline of rear attachment.

Rev. Form 6-57

- (a) Optional 4-speed transmission same as Overdrive
- (b) Optional Turboglide transmission same as regular production 3-speed
- (c) 4 pinions in "Positraction" axle
- (d) 3.55:1 rear axle used with special camshaft engines (9-32).
- (e) 3.55:1 rear axle used with 4-speed transmission (9-32).

AMA Specifications – Passenger Car

MAKE OF CAR CHEVROLET **MODEL YEAR** 1959 **DATE ISSUED** 7-15-58 **REVISED** 1-30-59
1200-1600-1800 Series
MODEL 283 cu.in. V-8 348 cu.in. V-8
(Standard) (Optional)

DRIVE UNITS—WHEELS

Type & material		Short spoke disc, pressed steel
Rim (size and flange type)		14x5J (a)(e)
Attachment	Type (bolt or stud)	Stud
	Circle diameter	4.75
	Number and size	5,7/16-20

DRIVE UNITS—TIRES

Standard	Size & ply	7.50 x 14-4 ply (b)
	Type - Nylon, etc.	Rayon
	Sidewall color	Black
Optional	Size & ply	7.50 x 14-4 ply (c)
	Type - Nylon, etc.	Rayon
	Sidewall color	White
Rev./mile at 30 mph		784 (d)
Inflation press.(cold)	Front	24 psi
	Rear	24 psi

BRAKES—SERVICE

Type		Servo-4 wheel hydraulic		
Power brake type		Vacuum power unit with regular production mstr. cyl.		
Effective area (sq. in.)		185.6		
Gross lining area (sq. in.)		199.5		
Percent brake effectiveness—front		56%		
Drum	Diameter	11		
		11		
Type and material		Composite-cast alloy iron rim, pressed steel web		
Banded or riveted		Banded		
Brake lining	Front Shoe	Material	Full molded asbestos composition	
		Size (length x width x thickness)	Front wheel	9.30 x 2.75 x .175
			Rear wheel	9.30 x 2.00 x .175
	Segments per shoe		1	
	Rear Shoe	Material	Full molded asbestos composition	
		Size (length x width x thickness)	Front wheel	11.70 x 2.75 x .175
Rear wheel			11.70 x 2.00 x .175	
Segments per shoe		1		
Wheel cylinder bore	Front	1.125		
	Rear	1.000		
Master cylinder bore		1.000		
Available pedal travel		6.4		
Line pressure at 100 lb. pedal load		725 (approx.)		
Shoe clearance adjustment		Adjust to light drag and back off 7 notches		

- a) Modified used as optional irregular production
- (b) 8.00 x 14-4 ply black std. equip. on convertible, sta. wgn.s., sed.del., sed.pickup.
- (c) Except convertible, sta. wgn.s., sed.del., sed.pickup. 8.00 x 14-4 ply black or white available on all models. 8.50 x 14-4 ply black avail. on sed.del. & sed. pickup.
- (d) 770 on 8.00 x 14-4 ply, 751 on 8.50 x 14-4 ply.
- (e) 14 x 5-1/2 J on 9-Passenger Station Wagon Model 1645

AMA Specifications – Passenger Car

MAKE OF CAR CHEVROLET MODEL YEAR 1959 DATE ISSUED 7-15-58 REVISED 10-16-58
1200-1600-1800 Series

MODEL 283 cu.in. V-8 348 cu.in. V-8
(Standard) (Optional)

BRAKES—PARKING

Type of control		Apply: Pendulum foot pedal. Release: Integral hand lever
Location of control		Under instrument panel, left of steering column
Operates on		Rear service brakes
If separate from service brakes	Type (internal or external)	None
	Drum diameter	None
	Lining size (length x width x thickness)	None

FRAME or UNITIZED CONSTRUCTION

Type and description	All welded "Y" frame with box girder side rails, box section front suspension crossmember, "Z" section intermediate rear crossmember, channel section rear crossmember and reinforced box girder center beam.
----------------------	---

SUSPENSION—GENERAL (See Supplemental page 16 for details on Air Suspension)*

Provision for car leveling		Front stabilizer bar
Provision for brake dip control		Mounting angle of front upper control arms
Provision for acc. squat control		Geometry of rear suspension
Special provisions for car jacking		None
Shock absorber front & rear	Type	Direct-double acting
	Make	Delco
	Piston dia.	1
Other special features		

SUSPENSION—FRONT

Type and description	Independent short and long arm, spherical joint outer pivots, rubber bushed inner pivots, coil springs.
----------------------	---

(Continued) Rev. Form 1-58

* Air Suspension:
 Air spring type
 Compressor data
 type
 make
 drive ratio
 Normal operating pressures
 spring rates
 leveling data

AMA Specifications -- Passenger Car

Supplement to Page 16

MAKE OF CAR CHEVROLET MODEL YEAR 1959 DATE ISSUED 7-15-58 REVISED 10-16-58

SUPPLEMENTARY INFORMATION

1200-1600-1800 Series

MODEL	283 cu.in. V8 (Standard)	348 cu.in. V8 (Optional)
-------	-----------------------------	-----------------------------

SUSPENSION - AIR

Type	"Level Air", with air spring at each wheel. Air supply system consisting of an engine driven air compressor, high pressure accumulator, junction block, anti-icing bottle integral with make up air intake, and three leveling valves.	
Air spring	Reservoir	Stamped sheet steel
	Bellows	Fabric reinforced rubber
Com-pressor	Type	Air cooled, single cylinder, reciprocating
	Make	Delco
	Drive ratio	1.25:1 (comp. pulley: engine)
Normal operating pressures	High pressure to air springs: 220-250 psi	
	Low pressure from air springs: 0 to 15 psi	
Leveling Valves	Locations	Right and left front, left rear -
	Orifice diameters	Right & left front reservoirs - inlet & exhaust: .020 Left rear reservoir - inlet: .031, exhaust: .042. Balance line: .020
	Dead band	3/8 (design)
Spring rates	Variable	

AMA Specifications – Passenger Car

MAKE OF CAR **CHEVROLET** MODEL YEAR **1959** DATE ISSUED **7-15-58** REVISED **11-30-59**
 1200-1600-1800 Series

MODEL _____ 283 cu.in. V8 (Standard) 348 cu.in. V8 (Optional)

SUSPENSION FRONT (cont.)

Spring	Type	Coil	
	Material	High alloy steel	
	Size (coil design height & I.D.; bar length x dia.)	10.30x3.802x141.5x.630	10.30x3.802x141.5x.630
	Spring rate (lb. per in.)	275	275
	Rate at wheel (lb. per in.)	-96	-96
	Design load (lb. @ design height)	1855 @ 10.30	1935 @ 10.30
Stabilizer	Type (link, linkless, frameless)	Link	
	Material & bar diameter	H.r. steel, .6875	

STEERING

Mechanical (std., opt., NA)		Standard	
Power (std., opt., NA)		Optional	
Wheel diameter		17"	
Turning diameter	Outside front	Wall to wall (l. & r.)	43.6 ft.
		Curb to curb (l. & r.)	40.8 ft.
	Inside rear	Wall to wall (l. & r.)	23.2 ft.
		Curb to curb (l. & r.)	24.5 ft.
Outside wheel angle with inside wheel at 20°		17°54'	
Mechanical	Gear	Type	Semi-reversible, recirculating ball
		Make	Saginaw
		Ratios	Gear 24:1 Overall 28:1
	No. wheel turns		5.80
Power	Type		Hydraulic. Power cylinder in linkage
	Make		Saginaw
	Trade name		Power-Touch
	Gear	Type	Semi-reversible, recirculating ball
		Ratios	Gear 20:1 Overall 24:1
		Pump driven by	
	Number wheel turns		5.20
Linkage	Type		Relay
	Location (front or rear of wheels, other)		Front
	Drag link (trans. or longit.)		None
	Tie rods (one or two)		Two

(Continued)

Rev. Form 1-58

AMA Specifications – Passenger Car

MAKE OF CAR CHEVROLET MODEL YEAR 1959 DATE ISSUED 7-15-58 REVISED 10-30-59

MODEL 1200-1600-1800 Series
283 cu.in. V-8 (Standard) 348 cu.in. V-8 (Optional)

STEERING (cont.)

Steering Axis	Inclination at camber (deg.)		7°11'
	Bearings (type)	Upper	Spherical joint, non-metallic bearing liner
		Lower	Spherical joint, non-metallic bearing liner
	Thrust		(a)
Wheel alignment (range and preferred)	Caster (deg.)		0° / 30'
	Camber (deg.)		±30' / 30'
	Toe-in (outside tread-inches)		1/16 - 1/8
Steering spindle & joint type			Forged steel with integral brake cyl. mount, detachable st. arms
Wheel spindle	Diameter	Inner bearing	1.2492-1.2497
		Outer bearing	.7491-.7496
	Thread size		3/4-20
	Bearing type		Ball

SUSPENSION—REAR

Type and description			Di-link, Upper control arm & bar, lower control arms, coil spring			
Drive and torq. taken through (see page 14)			Upper & lower control arms			
Spring	Type		Coil			
	Material		High alloy steel			
	Size (length x width, coil design height and I.D.; bar length & dia.)		9.55x3.639x139.25x.583			
	Spring rate (lb. per in.)		230			
	Rate at wheel (lb. per in.)		101			
	Design load (lb. at design height)		1560 @ 9.55			
	Mounting insulation type		None			
	If leaf	No. of leaves		None		
		Inserts	Type and size	None		
			Material	None		
Shackle (comp. or tens.)		None				
Stabilizer	Type (link, linkless, frameless)		None			
	Material		None			
Track bar type			Lateral, frame to rear axle			

(a) Vehicle load carried on lower spherical joints, no auxiliary bearings required for steering motion.

AMA Specifications - Passenger Car

MAKE OF CAR CHEVROLET MODEL YEAR 1959 DATE: ISSUED 7-15-58 REVISED 1-30-59

BODY-GENERAL DEFINITIONS

NOTE: Included in the dimension definitions listed on this and the following pages are those which have been adopted by the S.A.E. These are indicated by a number following the type of dimension, e.g. L 3. Additional dimensions have been added by the AMA Specifications Body Subcommittee for inclusion in the Questionnaire. These are shown by an additional letter, e.g., HA. Symbol "a" added as suffix to SAE dimensions indicates an AMA modification. The dimensions are developed from the following basic points:

1. Front and rear seat free "A" points are taken 5" forward of vertical tangent to seat back 15" from center of body.
2. Front and rear seat "B" points are located on seat back 15" from center of body at height of horizontal tangent to top of seat cushion.
3. Front seat is in the full down and normal rearmost position.
4. Loaded position—5 passenger, front 300 lb., rear 450 lb.; includes spare wheel, tire and tools, and full complement of gas, oil, water, and tires to recommended pressure, etc.
5. C/L (centerline).
6. D. L. O. (daylight opening, exposed glass dimension - pages 21, 23 & 25).
7. Ramp breakover angle (page 21) is the supplement of the included ramp angle (180° minus the included ramp angle) over which a car can pass without hanging up.

MODEL 1200-1600-1800 Series V8	4 Door Sedan	4 Door Station Wagon
--------------------------------	--------------	----------------------

BODY-TRUNK DIMENSIONS

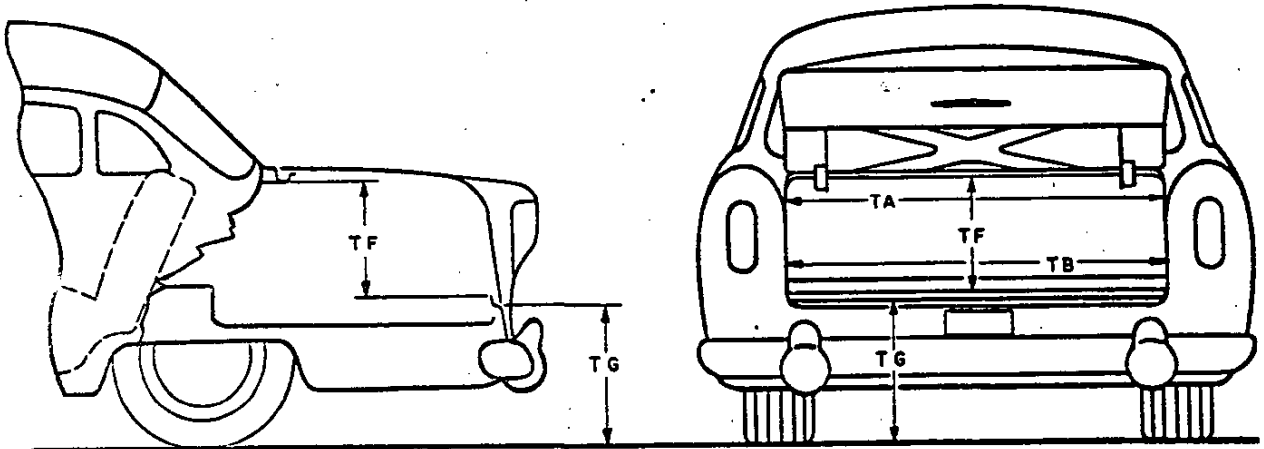

Usable trunk luggage capacity (see Section H1 of SAE Automotive Drafting Standards)	19.2 cu.ft.(b)	(b)
TA—Width across the top	52.0	-
TB—Width across the bottom	-	-
TF—Vertical dimension at C/L from bottom to top of opening.	7.0	-
TG—Vertical height from ground to trunk lower opening (normal surface of outside sheet metal - loaded)	28.4	-
Position of spare tire stowage	Nearly vertical, rh	Horizontal (a)
Method of holding lid open	Torsion bars, counterbal	2

(a) Vertical in rh sidewall on 9-passenger only. Rev. Form 6-57
 (b) Overall: Sedans 30.0 cu.ft. Station Wagon 92.0 cu.ft.(rear seat folded)
 Sport Coupe 32.0 cu.ft.(with luggage set 20.1)
 Convertible 29.5 cu.ft.(with luggage set 19.3)

AMA Specifications -- Passenger Car

Page 20

MAKE OF CAR CHEVROLET MODEL YEAR 1959 DATE ISSUED 7-15-58 REVISED 10-16-58

BODY--HEIGHT DIMENSIONS--INTERIOR

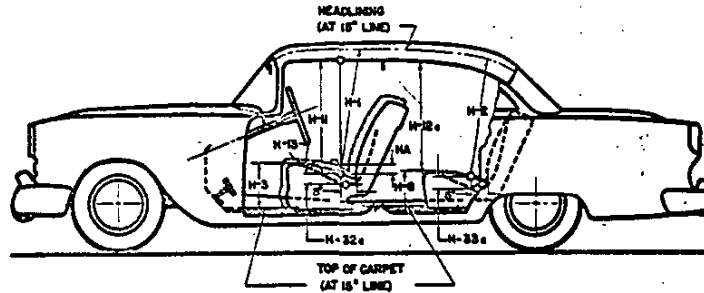

MODEL <u>1200-1600-1800 Series V8</u>	4-Door Sedan	4-Door Station Wagon
H1. Front headroom--from free "A" pt. to headlining at 8° back of vertical on 15" line. (For "A" pt. see note 1, page 19)	36.1	35.8
H2. Rear headroom--from free "A" pt. to headlining at 8° back of vertical on 15" line.	34.3	36.9(a) 34.0(b)
H3. Front cushion height above low point on floor carpet on 15" line (front edge of cushion).	9.2	9.3
H8. Rear cushion height above low point on floor carpet on 15" line (front edge of cushion).	13.8	12.2(a) 16.0(b)
H1. Entrance--front--cushion free "A" point to bottom windcord vertical.	29.3	29.2
H12a. Entrance -- rear -- top of cushion at vertical tangent to front of rear seat, to bottom of windcord in rear.	28.0	29.5
H13. Steering wheel clearance to seat cushion taken on arc (wheel turned for min. clearance).	5.2	
HA. Front seat maximum vertical rise at free "A" point.	.5	
HF. Front seat maximum vertical rise of free "A" point with multiple-position seat.	1.8	
H32a. Front seat depressed depth -- vertical dimension from free "A" point to depressed "A" point.	4.4	
H33a. Rear seat depressed depth -- vertical dimension from free "A" point to depressed "A" point.	4.5	4.4(a) 3.5(b)

Rev. Form 1-58

- (a) Rear seat (all wagons)
- (b) Third seat (9-pass.wagon only)

AMA Specifications – Passenger Car

MAKE OF CAR CHEVROLET MODEL YEAR 1959 DATE ISSUED 7-15-58 REVISED 11-30-59

BODY—HEIGHT DIMENSIONS—EXTERIOR

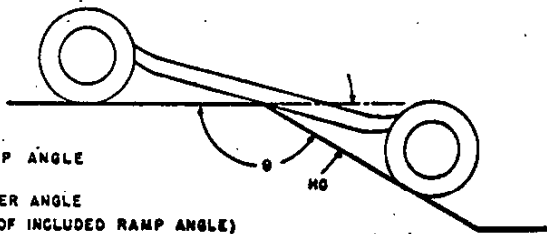
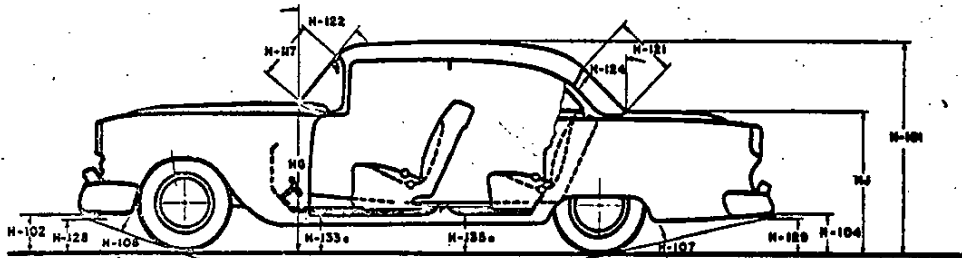

MODEL	1200-1600-1800 Series V-8	4-Door Sedan	4-Door Station Wagon
H101. Overall height - loaded.		56.0	56.3
HB. Overall height - curb weight.		58.1	58.4
H102. Front bumper bottom to ground at normal section.			11.9
H104. Rear bumper bottom to ground at normal section.			15.4
H106. Angle of appr.-fr. tire static loaded rad. to interfering pt. on fr. bumper, gd., other.			26°
H107. Angle of dep.-fr. tire static loaded rad. to interfering pt. on rr. bumper, gd., other.			12° 45'
HC. Ramp breakover angle.*			12° 30'
H117. Windshield DLO-slant height.			26.6
H121. Backlight DLO*-max., slant height.	22.7		14.0
H122. Windshield slope angle to vertical line on car axis.			48° 45'
H124. Backlight slope angle to vertical line on car axis.	59° 0'		25° 0'
H128. Ground to bottom of front bumper guard.			10.8
H129. Ground to bottom of rear bumper guard.			11.4
H133a. Bottom of front door to ground, min. dimension - car loaded.	11.7		11.9
H135a. Bottom of rear door to ground, min. dimension - car loaded.	11.5		11.7
HD. Min. road clear. (5 pass. load) & loc.		6.0 (at muffler)	
HE. Min. road clearance at rear axle.		7.3	
HG. Hood at rr. to grd.-vert. dim. excl. molding, fr. hood opening line at cowl (curb wt.)		NA	
HH. Max. ht., fr. grd. frt. of windshield (curb wt.)		NA	
HJ. Max. ht. fr. grd. back of r. window (curb wt.)		NA	

* See Notes, page 19.

AMA Specifications - Passenger Car

MAKE OF CAR CHEVROLET MODEL YEAR 1959 DATE ISSUED 7-15-58 REVISED 10-16-58

BODY-LENGTH DIMENSIONS

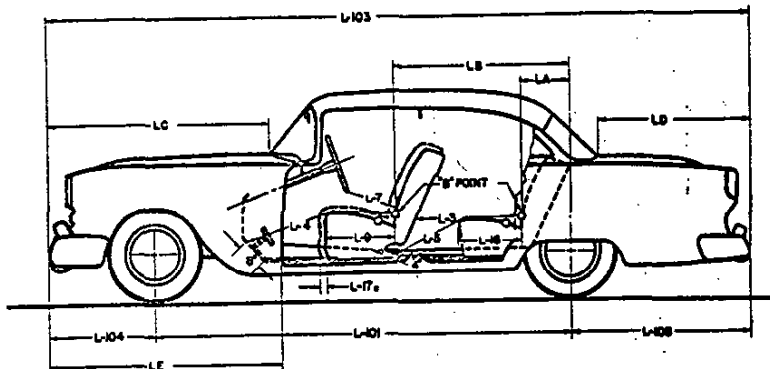

MODEL	4 Door Sedan	4 Door Station Wagon	
1200-1600-1800 Series V8			
* L3. Rear compartment of front seat back to rear seat back.	29.2	29.3(a) 34.5(b)	
* L4. Leg room—front—ball of foot to top of seat to seat back--15" line.	45.0	44.8	
* L5. Leg room—rear—from ball of foot to top of seat cushion and to seat back-	42.8	41.7(a) 38.3(b)	
L7. Steering wheel clearance to seat back taken on arc.	.	14.2	
* L9. Front seat depth (front edge to vert. tan. to seat back on 15" line).	19.0	18.3	
Interior	* L16. Depth of rear seat (front edge to seat back).	18.3	
	L17a. Total adjustment of front seat at front lower seat frame.	4.7(c)	
	LA. Rear seat "B" point to center line of rear axle.	18.5	18.6(a) 18.0(b)
	LB. Front seat "B" point to center line of rear axle.	.	53.7
	LC. Front of car to base of windshield.	52.8	
	LD. Rear of car to base of rear window or upper structure.	45.4	14.7
	LE. Front of car to front edge of front door.	65.1	
Exterior	L101. Wheelbase.	119.0	
	L103. Overall length (bumper to bumper inc. guards).	210.9	
	L104. Overhang—front including bumper guards.	32.6	
	L105. Overhang—rear including bumper guards.	59.3	

* Dimension taken on 15" line—see notes 1 & 2, page 19.

- (a) Rear seat (all wagons)
- (b) Third seat (9-pass. wagon only)
- (c) 4.8 on multiple position seat.

AMA Specifications - Passenger Car

Page 23

MAKE OF CAR CHEVROLET MODEL YEAR 1959 DATE ISSUED 7-15-58 REVISED 11-30-59

BODY - WIDTH DIMENSIONS

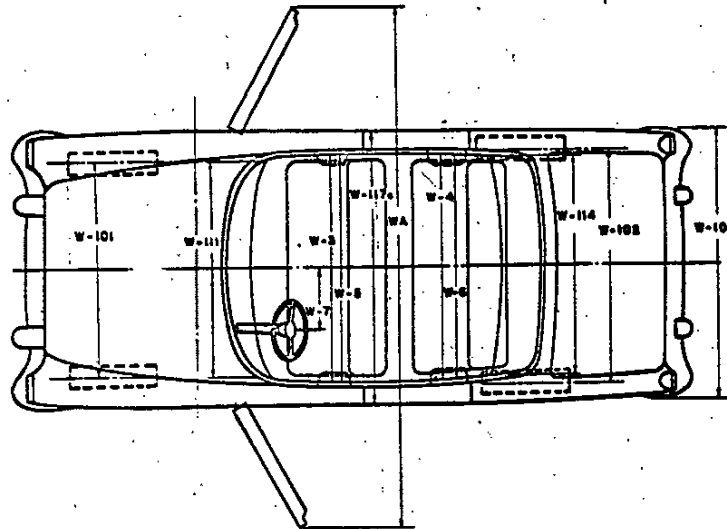

MODEL 1200-1600-1800 Series V8		4-Door Sedan	4-Door Station Wagon
Interior	W3. Front shoulder room, at garnish moulding height or nearest interference 5" forward of seat back.	60.5	60.5
	W4. Rear shoulder room, at garnish moulding height or nearest interference 5" forward of seat back.	59.7	59.2(a) 57.5(b)
	W5. Front hip room, at top of seat 5" forward of vert. tan. to seat back.	66.1	66.1
	W6. Rear hip room, at top of seat 5" forward of vert. tan. to seat back.	65.5	66.0(a) 66.5(b)
	W7. Steering wheel center to center of body.		15.9
	Exterior	W101. Front tread at ground.	
W102. Rear tread at ground.			59.3
W103. Max. overall width of car including bumpers or mouldings.		85.5	79.9
WA. Max. overall width of car with doors open.		148.9 (front) (c)	148.9 (front) (c)
W111. Windshield DLO, max. width.			64.6
W114. Back window DLO, max. width.		61.2	45.4
W117a. Max. body width at center pillar, less hardware and applied moldings.		79.1	79.0

Rev. Form 1-58

- (a) Rear seat (all wagons)
- (b) Third seat (9-pass. wagon only)
- (c) Doors in check position

AMA Specifications - Passenger Car

Page 24

MAKE OF CAR CHEVROLET MODEL YEAR 1959 DATE ISSUED 7-15-58 REVISED 1-30-59

STATION WAGON - CARGO SPACE DIMENSIONS

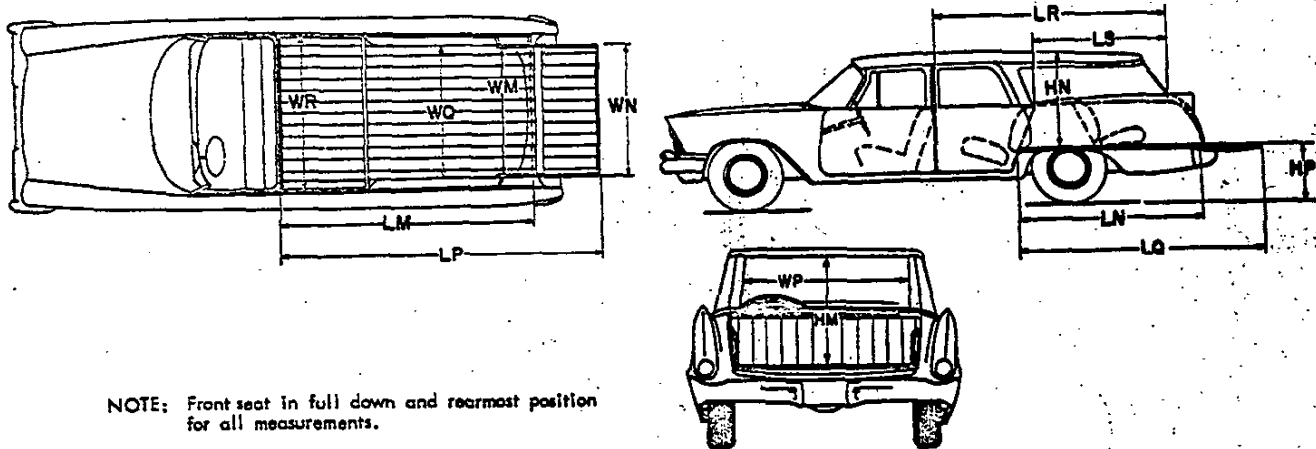

NOTE: Front seat in full down and rearmost position for all measurements.

MODEL 1200-1600-1800 Series W

4-Door Station Wagon

LM Floor length from bottom of front seat to inside of tail gate in raised position.	94.8
LN Floor lgth. from bottom of second seat to inside of tail gate in raised position.	60.0
LP Floor lgth. from bottom of front seat to end of tail gate in lowered position.	120.1
LQ Floor lgth. from bottom of second seat to end of tail gate - tail gate lowered.	85.3
HM Maximum hght. of rear opening - tail gate lowered.	26.7
WM Rear end opening width at floor.	47.6
WN Rear end opening width at top of tail gate.	46.0
WQ Minimum distance between wheelhouses.	46.4
WP Maximum width of rear opening above raised tail gate.	44.6
WR Maximum width of cargo space at floor.	66.0
LR Cargo horizontal distance from top rear of front seat back to top of tail gate.	81.2
LS Cargo horizontal distance from top rear of second seat back to top of tail gate.	48.2
HN Maximum height of roof above floor at center line of car.	32.1
HP Platform height of end of lowered tail gate - curb weight.	27.5
Third Seat - facing direction.	Rearward (a)

(a) 9-passenger model only

Rev. Form 1-58

AMA Specifications - Passenger Car

MAKE OF CAR CHEVROLET MODEL YEAR 1959 DATE ISSUED 7-15-58 REVISED 1-30-59
 MODEL 1200-1600-1800 Series V-8

BODY—MISCELLANEOUS INFORMATION

Drs. hinged (front, rear)	Front doors	Front
	Rear doors	Front
Type of finish (lacquer, enamel).		Acrylic lacquer
Hood hinge location (front, rear).		Rear
Hood counterbalanced (yes, no).		Yes
Hood release control (internal, external).		External
Vehicle (Serial) No. Location		Left front body hinge pillar
Engine No. location		Front right side of cylinder block
Theft protection - type		Shielded ign.lock terminals, key removable in "lock" or "on" pos. only
Vent window control method (crank, friction pivot).		Crank
Windshield type (single curved, compound curved, other)		Single, compound curved
Rear window type (flat, curved, one piece, three piece)		Single curved
Side glass type (curved, flat)		Flat
Windshield glass area D.L.O.		1740.1 (a)
Backlight glass area D.L.O.		(b)
Total glass area D.L.O.		(c)

BODY—TYPES AND STYLE NAMES —

Body type, number of passengers & style names; use manufacturer's code for series & body style.

BODY STYLES:		CODES
<u>Biscayne</u>	1211	2-door sedan - 6 passenger
	1219	4-door sedan - 6 passenger
	1221	2-door utility sedan - 3 passenger
	1270	2-door sedan delivery - 1 passenger
<u>El Camino</u>	1280	2-door sedan pickup - 3 passenger
<u>Bel Air</u>	1611	2-door sedan - 6 passenger
	1619	4-door sedan - 6 passenger
	1639	4-door sport sedan - 5 passenger
<u>Impala</u>	1819	4-door sedan - 6 passenger
	1837	2-door sport coupe - 5 passenger
	1839	4-door sport sedan - 5 passenger
	1867	2-door convertible - 5 passenger
<u>Station Wagon</u>	1215	2-door station wagon - 6 passenger (Brookwood)
	1235	4-door station wagon - 6 passenger (Brookwood)
	1635	4-door station wagon - 6 passenger (Parkwood)
	1645	4-door station wagon - 9 passenger (Kingswood)
	1835	4-door station wagon - 6 passenger (Nomad)

- (a) Impala sport coupe, sport sedan, convertible: 1711.8
 (b) 2-4 door sedans: 1553.7, sport sedan: 1309.1, sport coupe: 1726.8, convertible (plastic): 963.9, station wagons: 623.2, sedan delivery: 579.2, sedan pickup 1034.5
 (c) 2-door sedan: 4737.7 (utility sedan: 4722.8), 4-door sedans 4687.1, sport sedan: 4148.6, sport coupe: 4670.1, convertible (includes plastic backlight) 3635.1, 2-door sta.wgn.: 4964.0, 4-door sta. wgn. 4961.7, sedan delivery: 3140.1, sedan pickup: 3465.8.

AMA Specifications -- Passenger Car

PAGE 27

INDEX

SUBJECT	PAGE NO.	SUBJECT	PAGE NO.
Air Suspension	16	Lamp Bulbs	11
Angles of Approach, Departure	21	Legroom	22
Automatic Transmission	1, 13	Lengths - Car, & Body Interior	1, 22
Axis, Steering	18	Lifters, Valve	4
Axle, Rear	1, 14	Linings - Clutch, Brake	12, 15
Battery	8	Lubrication	5, 6, 12, 13, 14
Bearings, Engine	3, 4, 7	Motor, Starting	8
Belts - Fan, Generator, Water Pump	7	Muffler	6
Body - General Information, Types	19, 25	Overdrive	13
Height Dimensions	21	Piston Pins & Rings	3
Length Dimensions	22	Pistons	2, 3
Overall Dimensions	1, 21, 22, 23	Power Brakes	15
Trunk Capacities, Opening Dimensions	19	Power Steering	17
Width Dimensions	23	Propeller Shaft, Universal Joints	14
Brakes - Parking, Service, Power	15, 16	Pumps - Oil, Fuel	6
Camber	18	Water	7
Camshaft	4	Radiator, Hoses	7
Capacities		Ramp Break-over Angle	21
Cooling System	7	Ratios - Axle	1, 14
Fuel Tank	6	Compression	1, 2
Lubricants		Steering	17
Engine Crankcase	6	Transmission	12, 13
Transmission and Overdrive	12, 13	Rear Axle	1, 14
Rear Axle	14	Regulator - Generator	8
Carburetor	6	Rims	15
Caster	18	Rings, Piston	3
Choke, Automatic	6	Rods - Connecting	3
Circuit Breakers, Fuses	11	Shock Absorbers, Front & Rear	16
Clearance, Ground	21	Spark Plugs	9
Clutch - Pedal Operated	12	Speedometer	10
Coil, Ignition	9	Springs - Front & Rear Suspension	17, 18
Connecting Rods	3	Valve, Engine	5
Cooling System	7	Stabilizer (Sway Bar) - Front & Rear	17, 18
Crankshaft	4	Starting Motor	8
Cylinders and Cylinder Head	2	Steering	17, 18
Distributor - Ignition	9	Suppression - Ignition, Radio	9
Electrical System	8, 9, 10, 11	Suspension - Front & Rear	16, 17, 18
Engine		Switches	10
Bore, Stroke, Displacement, Type	1, 2	Tailpipe	6
Compression Ratio	1, 2	Thermostat, Cooling	7
Firing Order, Cylinder Numbering	2, 9	Timing, Engine & Valve	4, 5, 9
General Information, H.P. & Torque	1, 2	Tires	1, 15
Lubrication	5, 6	Toe in	18
Exhaust System	6	Torque Converter	13
Fan, Cooling	7	Torque - Engine, Rated	1, 2
Filters - Engine Oil, Fuel System	6	Transmission - Types	1, 12, 13
Frame	16	Automatic	1, 13
Front Suspension	16, 17	Manual & Overdrive	12, 13
Fuel, Fuel Pump, Fuel System	6	Ratios	12, 13
Fuel Injection	1, 6	Tread	1, 23
Fuses, Circuit Breakers	11	Turning Diameter	17
Generator and Regulator	8	Universal Joints, Propeller Shaft	14
Glass	21, 23, 25	Valves - Intake & Exhaust	4, 5
Headroom - Body	20	Vibration Damper	4
Heights - Car & Body	1, 20, 21	Voltage Regulator	8
Hood	25	Water Pump	7
Horns	10	Weights - Shipping, Curb	26
Horsepower - Brake, Rated, Taxable	1, 2	Wheel Alignment	18
Ignition System	9	Wheelbase	1, 22
Inflation - Tires	15	Wheels & Tires	15
Instruments	6, 10	Wheel Spindle	18
Kingpin (Steering Axis)	18	Widths - Car & Body	1, 23
		Windshield	21, 23, 25
		Windshield Wiper	10



11

