

# CHEVROLET

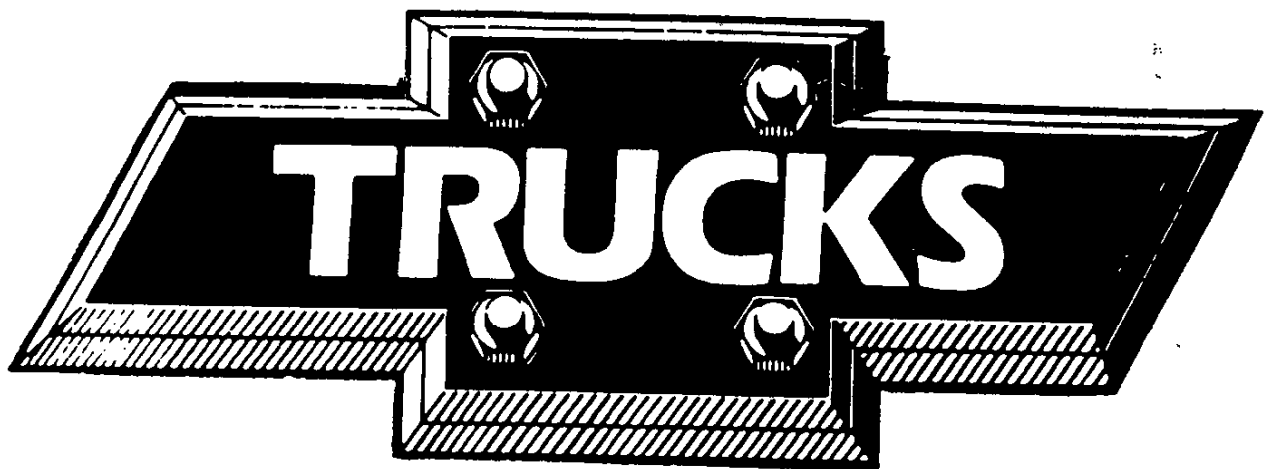

1955

2nd



1955  
TRUCK  
*SECOND SERIES*

MODELS

Type	Series	L F Cowl Chassis	W S Cowl Chassis	Cab Chassis	Pickup Truck	Panel Truck	Suburban Carryall	Sedan Delivery	Platform Truck	Stake Truck	Combo Carrier	Forward Control Chassis
Light Duty Conventional	1500							1508*				
	3100	3102	3112	3103	3104	3115	3106 3116				3124	
	3200				3204							
Medium Duty Conventional	3400											3442
	3500											3542
	3600	3602	3612	3603	3604				3608	3609		
	3700											3742
	3800	3802	3812	3803	3804	3805			3808	3809		
Heavy Duty Conventional	4100	4102	4112	4103					4108	4109		
	4400	4402	4412	4403					4408	4409		
	4500	4502										
Heavy Duty L. C. F. (Special)	5100S			5103S								
	5400S			5403S					5408S	5409S		
	5700S			5703S								
Heavy Duty L. C. F.	5100			5103								
	5400			5403					5408	5409		
	5700			5703								
Heavy Duty Conventional (Special)	6100S	6102S	6112S	6103S					6108S	6109S		
	6400S	6402S	6412S	6403S					6408S	6409S		
	6500S	6502S	6512S	6503S								
Heavy Duty Conventional	6100	6102	6112	6103					6108	6109		
	6400	6402	6412	6403					6408	6409		
	6500	6502	6512	6503								
	6700	6702										
	6800	6802										

\* - See Passenger Car Section for Sedan Delivery Specifications.

**SERIAL NUMBERS**

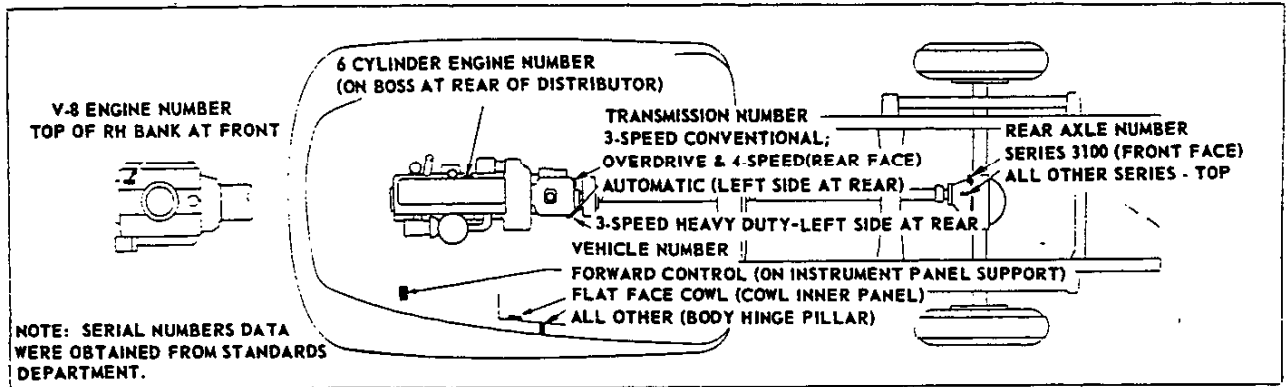

NOTE: SERIAL NUMBERS DATA WERE OBTAINED FROM STANDARDS DEPARTMENT.

**VEHICLE SERIAL NUMBER**

Example: L 255 K 001453

Series	Model Year	Assembly Plant	Unit Number
H 3100		A Atlanta	(Begin with
M 3200		B Baltimore	001001 at
F 3400		F Flint	each plant
G 3500		J Janesville	regardless
J 3600		K Kansas City	of series)
K 3700		L Los Angeles	
L 3800		N Norwood	
N 4100		O Oakland	
P 4400		S St. Louis	
R 4500		T Tarrytown	
S 5100			
T 5400			
U 5700			
V 6100			
W 6400			
X 6500			
Y 6700			
Z 6800			
SS 5100S		SV 6100S	
ST 5400S		SW 6400S	
SU 5700S		SX 6500S	

φ - "V" prefix to the series designation will identify models using the RPO V-8 Engine •

**ENGINE SERIAL NUMBER**

Example: 0601453 F 255 T

Unit Number	Assembly Plant	Model Year	Type
(Begin with	F-Flint		
0001001 at	T-Tonawanda	(On 8 cyl engines, 55)	
each plant		(On 6 cyl engines, 2550)	
6 cyl and			
8 cyl engines			
are numbered			
separately)			

Type

- X - 3100-3200 Regular
- M - 3100-3200 with RPO 314
- SC - 31-3200 with RPO 227
- DC - 31-3200 RPO 408 (except Auto. Trans.)•
- B - 31-3200 RPO 408 (Automatic Transmission)•
- XA - 3600 Regular
- MA - 3600 with RPO 314
- SA - 3600 with RPO 227
- DA - 3600 RPO 408 (except Auto. Trans.)•
- BA - 3600 RPO 408 (Automatic Transmission)•
- T - 3400-3500-3700 Regular
- L - 3400-3500-3700 with RPO 314
- XB - 3800 Regular
- MB - 3800 with RPO 314
- SB - 3800 with RPO 227
- DB - 3800 RPO 409 (except Auto. Trans.)•
- BB - 3800 RPO 409 (Automatic Transmission)•
- S - 4000 Regular
- PA - 4000 RPO 225 (Loadmaster engine)
- D - 4000 RPO 409
- E - 5000 Regular, 6000 RPO 409•
- P - 6000 Regular
- N - 6000 RPO 225 (Jobmaster engine)

**REAR AXLE SERIAL NUMBER**

Example: AF 2 12

Assembly Plant and Model Year	Type and Series	Month	Day of Month
AF	31-3200 Regular, 3.9 ratio		
AG	31-3200, with RPO 315, 4.11		
CA	34-35-3700 Regular, 5.14 ratio		
CC	3600 Regular, also with RPO's 314, 316, 318, 4.57 ratio		
CD	3600, with RPO 282, 4.57 ratio		
CE	34-35-3700 with RPO's 314, 316, 318, 5.14 ratio		
CF	3800 Regular, also with 34-35 3700, RPO 272		
CB	34-35-37-3800, with RPO 295, 5.14 ratio		
CG	4000 Regular, 6.17 ratio		
CH	5000 Regular, also 6000 RPO 252 6.17 ratio		
CJ	6000 Regular, 6.17 ratio		
CM	5-6000, RPO 252, 7.2 ratio		
CK	5-6000, RPO 202; Also 4000 RPO 243, 5.83/7.95 ratio		
CL	5-6000, RPO 251 6.40/8.72 ratio		

**TRANSMISSION IDENTIFICATION**  
Three Speed Regular and Overdrive

Example: M 2 21

Plant	Month	Day of Month
M-Muncie		
S-Saginaw		

**Four Speed Transmission**

Example: T 2 21

Plant	Month	Day of Month
T-Toledo		

**Automatic Transmission**

Series	31-3200	34-35-36-37-3800
Plate Color	Orange	Black
Plate Location	On left side at rear of transmission	

**Three Speed Heavy Duty Transmission**

Example: W B 21 5 2

Manufacturer	Month*	Day of Month	Year	Shift
* - "A" for January, "B" for February, etc.				

Q - The first number of model year numeral group indicated 2nd series 1955 truck models.  
3-25-55. Revised: 8-1-55 •-Data Added, ♦ - Data Revised,  
**CHEVROLET 1955 SPECIFICATIONS - TRUCK**

CHASSIS AND BODY DIMENSIONS

MODEL 3102 FLAT FACE COWL CHASSIS  
 MODEL 3112 WINDSHIELD COWL CHASSIS

MINIMUM GVW 4000 LBS.  
 MAXIMUM GVW 5000 LBS.

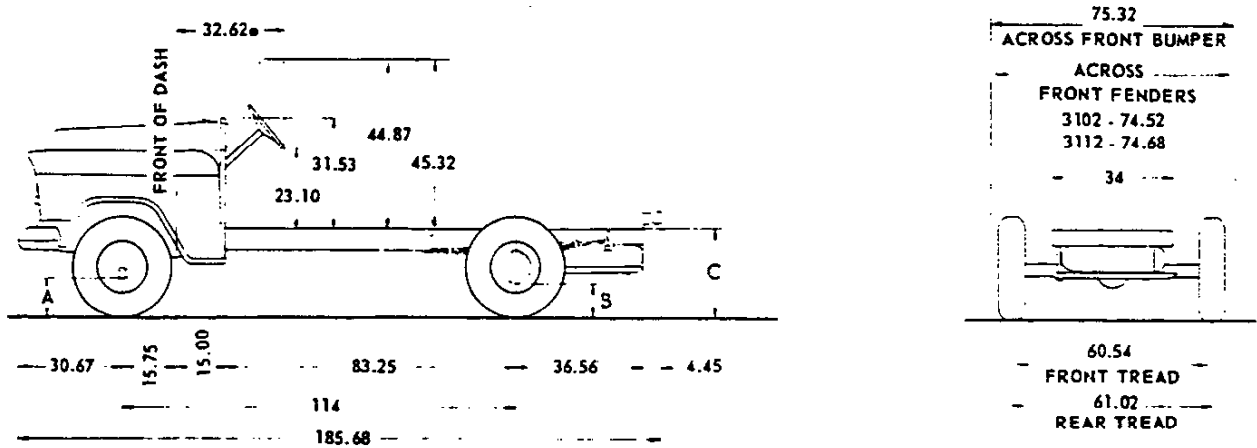

Equipment	Height Without Body and Payload			Tires	
	A	B	C	Front	Rear
Standard	8.01	7.65	26.12	6.70-15-4pr	6.70-15-4pr
Minimum for Max GVW	8.44	8.08	26.75 <sup>e</sup>	6.50-16-6pr	6.50-16-6pr

VEHICLE WEIGHTS AND LOAD DISTRIBUTION

MODEL	WITH STANDARD EQUIPMENT						WITH MINIMUM EQUIPMENT FOR MAXIMUM GVW			
	Shipping			Curb			Body and Payload	Payload Distribution		Body Length
	Front	Rear	Total	Front	Rear	Total		Front	Rear	
3102 <sup>Ⓞ</sup>	1490	845	2335	1565	910	2475	2450	Determined by style, length and weight of body.		
3112 <sup>Ⓞ</sup>	1560	900	2460	1630	970	2600	2350			

<sup>Ⓞ</sup> Estimated Weight

3-25-55. Revised: 8-1-55. <sup>e</sup>-Data Revised  
 64 - MODELS 3102 AND 3112 DATA

CHEVROLET 1955 SPECIFICATIONS -TRUCK

### CHASSIS AND BODY DIMENSIONS

#### MODEL 3103 CAB CHASSIS

**MINIMUM GVW 4000 LBS.  
MAXIMUM GVW 5000 LBS.**

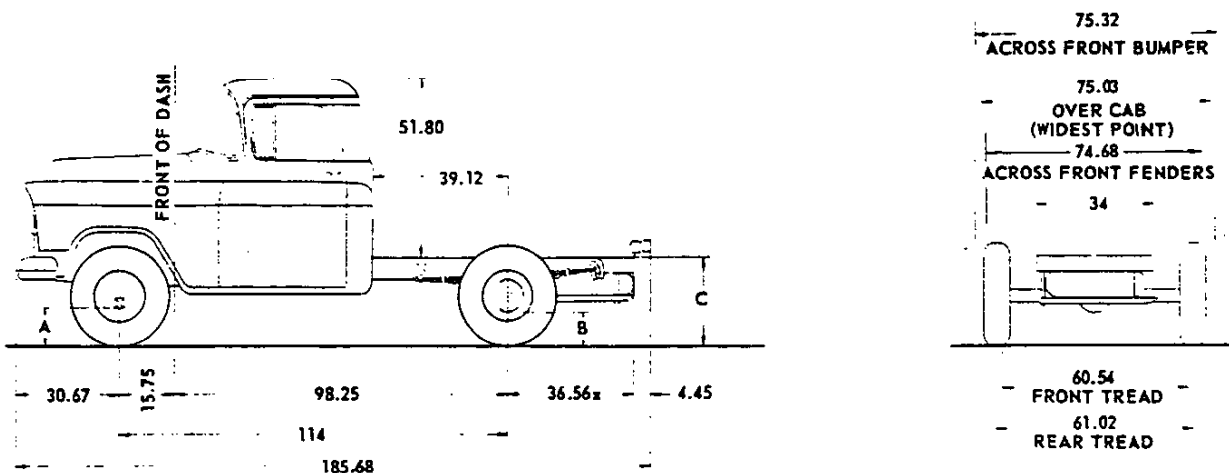

Equipment	Height Without Body and Payload			TIRES	
	A	B	C	Front	Rear
Standard	8.01	7.05	25.75	6.70-15-4pr	6.70-15-4pr
Minimum for Max GVW	8.44	8.08	26.25 x	6.50-16-6pr	6.50-16-6pr

#### MODEL 3104 PICKUP TRUCK

**MINIMUM GVW 4000 LBS.  
MAXIMUM GVW 5000 LBS.**

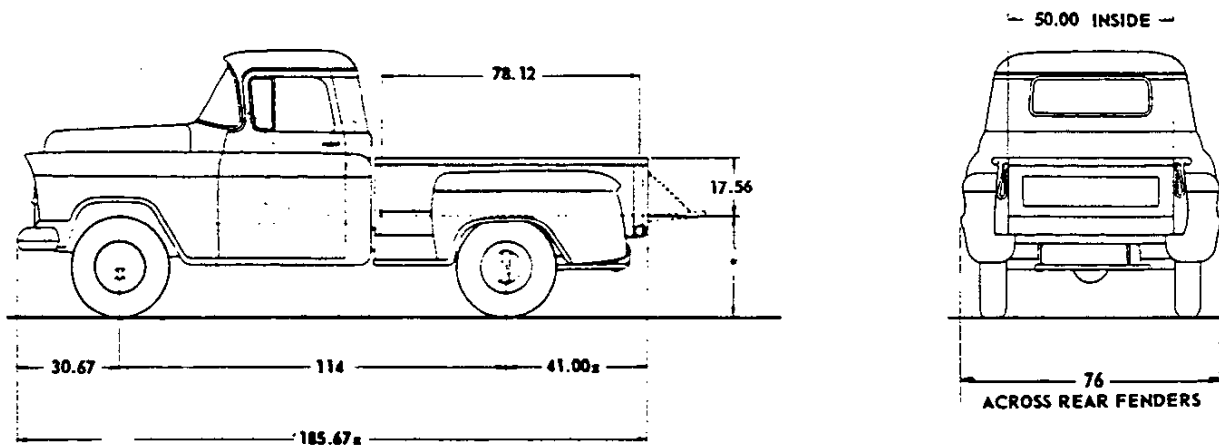

Equipment	* Platform Height:		TIRES	
	Loaded	Unloaded	Front	Rear
Standard	25.47	27.73	6.70-15-4pr	6.70-15-4pr
Minimum for Max GVW	24.25	28.82	6.50-16-6pr	6.50-16-6pr

### VEHICLE WEIGHTS AND LOAD DISTRIBUTION

MODEL	WITH STANDARD EQUIPMENT						WITH MINIMUM EQUIPMENT FOR MAXIMUM GVW			
	Shipping			Curb			Body and/or Payload	Payload Distribution		Body Length
	Front	Rear	Total	Front	Rear	Total		Front	Rear	
3103 •	1895	955	2850	1965	1025	2990	1950	12%	88%	48
								6%	94%	60
								1%	99%	72
3104 •	1905	1305	3210	1975	1375	3350	1575	0%	100%	78

3-25-55. Revised: 8-1-55. •-Production weights replace estimated weights x-Data Revised.

CHEVROLET 1955 SPECIFICATIONS - TRUCK

MODELS 3103 AND 3104 DATA - 65



CHASSIS AND BODY DIMENSIONS

MODEL 3105 PANEL TRUCK

MINIMUM GVW 4000 LBS.  
MAXIMUM GVW 5000 LBS.

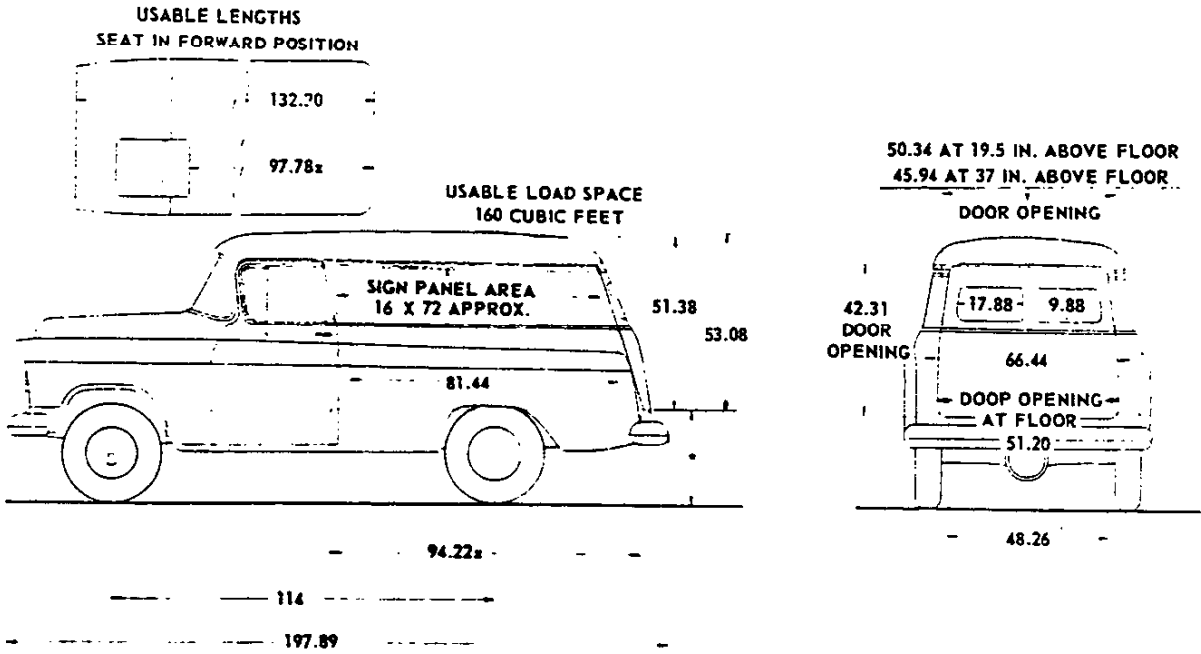

Equipment	Platform Height		TIRES	
	Loaded	Unloaded	Front	Rear
Standard	25.06	26.48	6.70-15-4pr	6.70-15-4pr
Minimum for Max GVW	24.30	28.19	6.50-16-6pr	6.50-16-6pr

VEHICLE WEIGHTS AND LOAD DISTRIBUTION

MODEL	WITH STANDARD EQUIPMENT						WITH MINIMUM EQUIPMENT FOR MAXIMUM GVW		
	Shipping			Curb			Payload	Payload Distribution	
	Front	Rear	Total	Front	Rear	Total		Front	Rear
3105 e	1815	1625	3440	1885	1695	3580	1350	5%	95%

3-25-55. Revised: 8-1-55, e-Production weights replace estimated weights x-Data Revised.

66 - MODEL 3105 DATA

CHEVROLET 1955 SPECIFICATIONS - TRUCK

### CHASSIS AND BODY DIMENSIONS

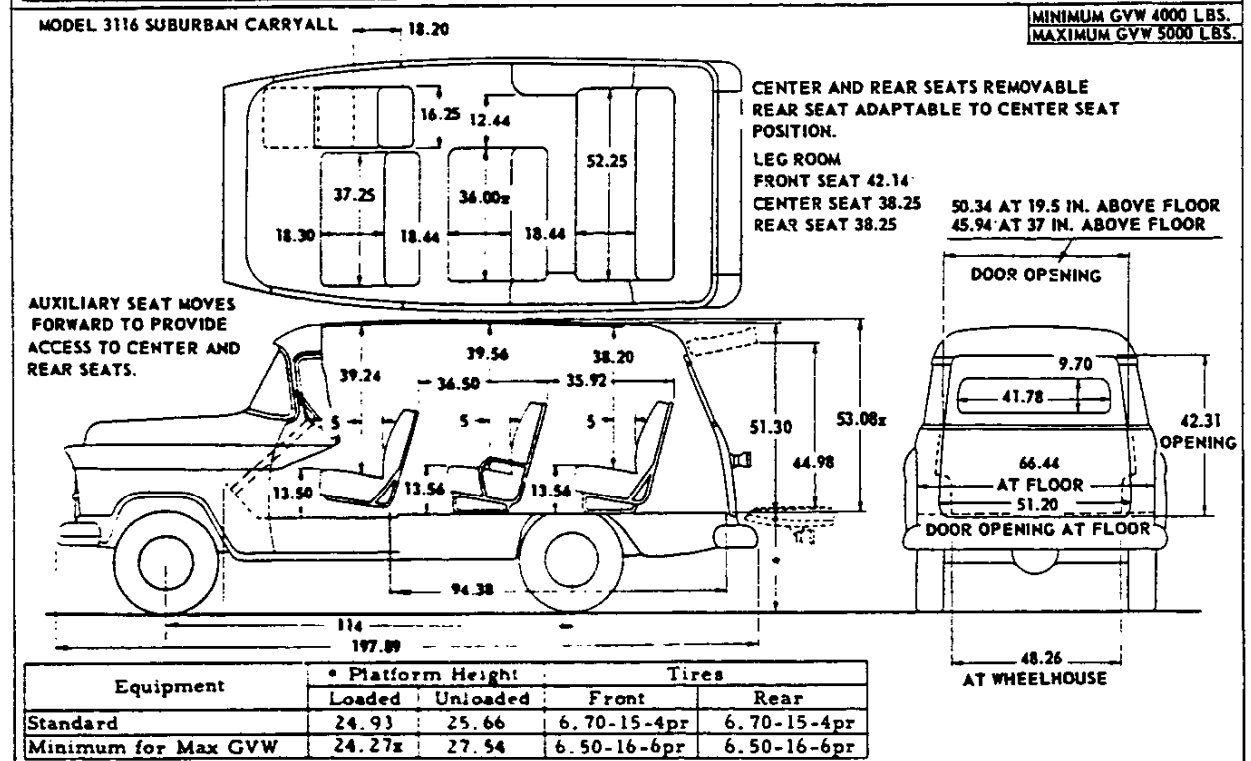
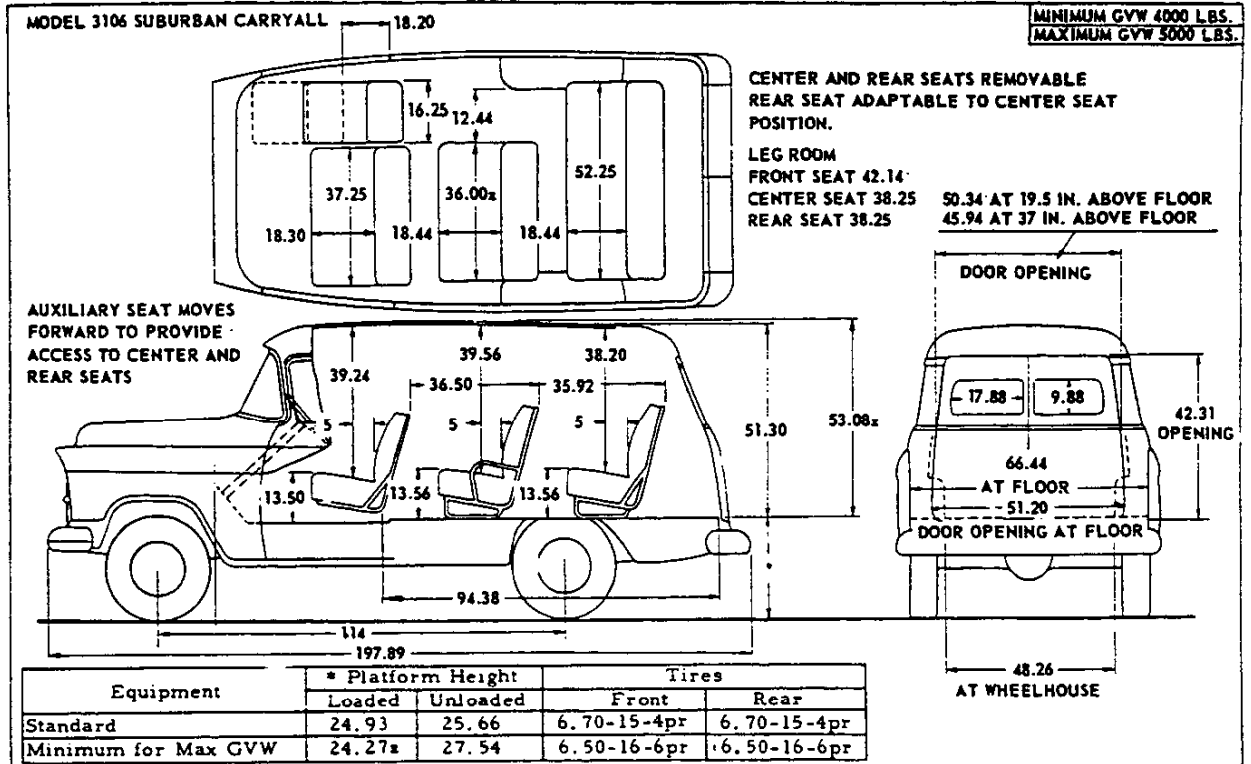

### VEHICLE WEIGHTS AND LOAD DISTRIBUTION

MODEL	WITH STANDARD EQUIPMENT						WITH MINIMUM EQUIPMENT FOR MAXIMUM GVW		
	Shipping			Curb			Payload	Payload Distribution	
	Front	Rear	Total	Front	Rear	Total		Front	Rear
3106 •	1755	1870	3625	1825	1940	3765	1200	4%	96%
3116 •	1755	1880	3625	1825	1950	3775	1200	4%	96%

3-25-55. Revised: 8-1-55. •-Production weights replace estimated weights x-Data Revised.

CHASSIS AND BODY DIMENSIONS

MODEL 3124 CAMEO CARRIER

MINIMUM GVW 4000 LBS.  
MAXIMUM GVW 5000 LBS.

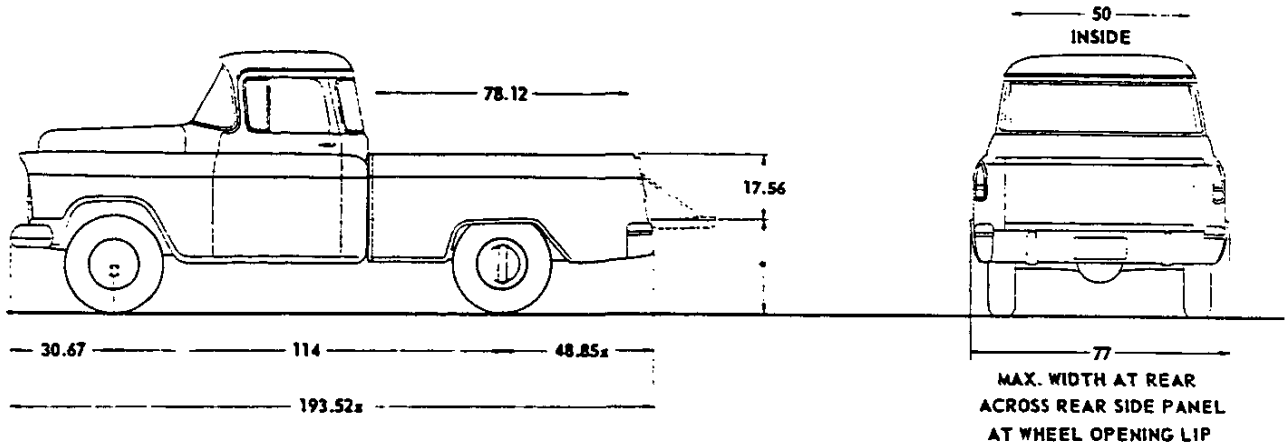

Equipment	* Platform Height		Tires	
	Loaded	Unloaded	Front	Rear
Standard	25.00	27.00	6.70-15-4 pr	6.70-15-4 pr
Minimum for Max GVW	23.80x	28.75x	6.50-16-6 pr	6.50-16-6 pr

VEHICLE WEIGHTS AND LOAD DISTRIBUTION

MODEL	WITH STANDARD EQUIPMENT						WITH MINIMUM EQUIPMENT FOR MAXIMUM GVW			
	Shipping			Curb			Payload	Payload Distribution		Body Length
	Front	Rear	Total	Front	Rear	Total		Front	Rear	
3124 e	1855	1500	3355	1925	1570	3495	1425	0%	100%	78

3-25-55. Revised: 8-1-55. e-Production weights replace estimated weights x-Data Revised.

68-MODEL 3124 DATA

CHEVROLET 1955 SPECIFICATIONS - TRUCK

CHASSIS AND BODY DIMENSIONS

MODEL 3204 PICKUP TRUCK

MINIMUM GVW 4000 LBS.  
MAXIMUM GVW 5000 LBS.

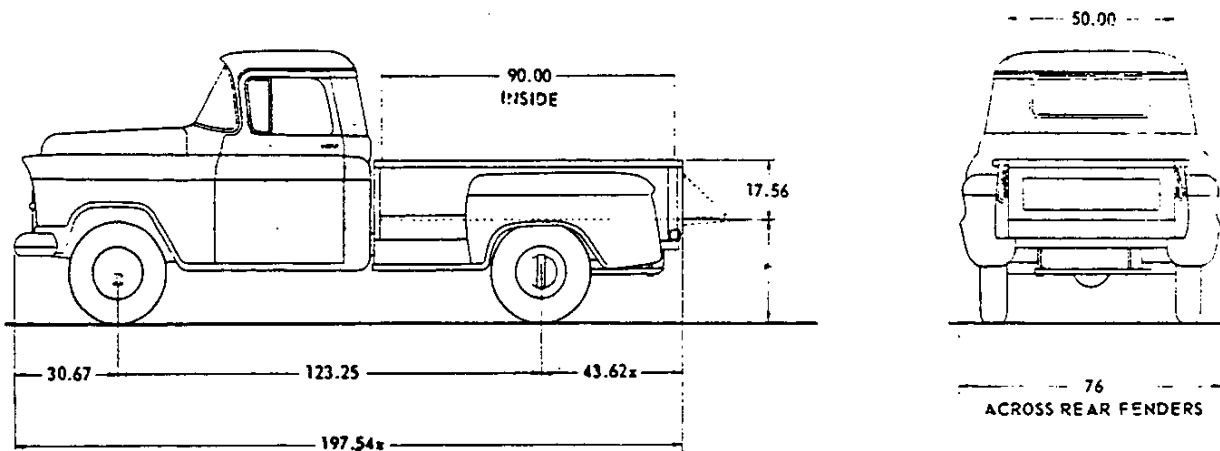

Equipment	* Platform Height		Tires	
	Loaded	Unloaded	Front	Rear
Standard	25.47	27.73	6.70-15-4pr	6.70-15-4pr
Minimum for Max GVW	24.25	28.82	6.50-16-6pr	6.50-16-6pr

VEHICLE WEIGHTS AND LOAD DISTRIBUTION

MODEL	WITH STANDARD EQUIPMENT						WITH MINIMUM EQUIPMENT FOR MAXIMUM GVW			
	Shipping			Curb			Payload	Payload Distribution		Body Length
	Front	Rear	Total	Front	Rear	Total		Front	Rear	
3204 ●	1955	1350	3305	2035	1410	3445	1475	1%	99%	90

3-25-55. Revised: 8-1-55, ●-Production weights replace estimated weights x-Data Revised.

CHASSIS AND BODY DIMENSIONS

MODELS 3442, 3542, 3742 FORWARD CONTROL CHASSIS

MINIMUM GVW 6600 LBS.  
MAXIMUM GVW 10,000 LBS.

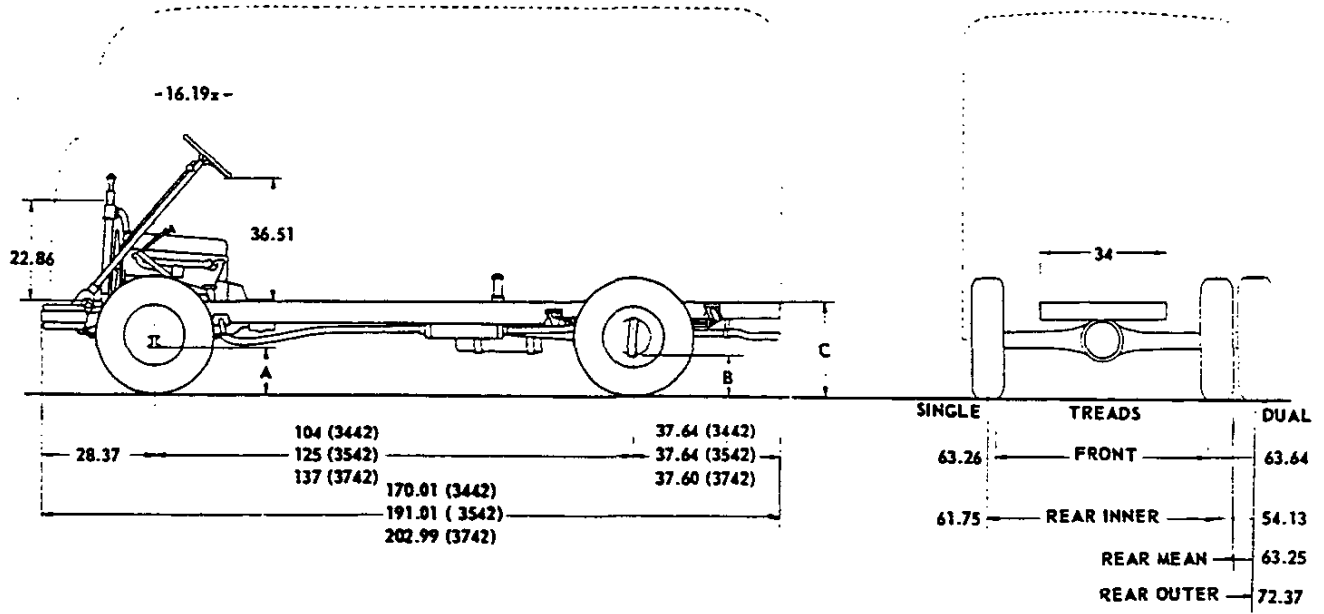

Equipment	Height Without Body and Payload					TIRES <sub>x</sub>		
	3442-3542-3742			3442	3542	3742	Front	Rear
	A	B	C					
Standard	6.94	8.88	27.73	27.60	27.55	7.00-17-6pr	7.00-17-6pr	
Minimum for Max GVW	7.44	9.38	27.94	27.90	27.88	7.00-18-8pr	7.00-18-8pr Dual	

VEHICLE WEIGHTS AND LOAD DISTRIBUTION

MODEL	WITH STANDARD EQUIPMENT						WITH MINIMUM EQUIPMENT FOR MAXIMUM GVW			
	Shipping			Curb			Body and Payload	Payload Distribution		Body Length
	Front	Rear	Total	Front	Rear	Total		Front	Rear	
3442 ⊕	1620	980	2600	1695	1155	2850	6775	Determined by style, length and weight of body.		
3542 ●	1765	955	2720	1800	1110	2910	6700			
3742 ●	1775	955	2730	1810	1110	2920	6675			

⊕ - Estimated Weight

3-25-55. Revised: 8-1-55. ●-Production weights replace estimated weights x-Data Revised.  
70 - MODELS 3442, 3542, 3742 DATA

CHEVROLET 1955 SPECIFICATIONS - TRUCK

CHASSIS AND BODY DIMENSIONS

MODEL 3602 FLAT FACE COWL CHASSIS  
 MODEL 3612 WINDSHIELD COWL CHASSIS

MINIMUM GVW 5400 LBS.  
 MAXIMUM GVW 6900 LBS.

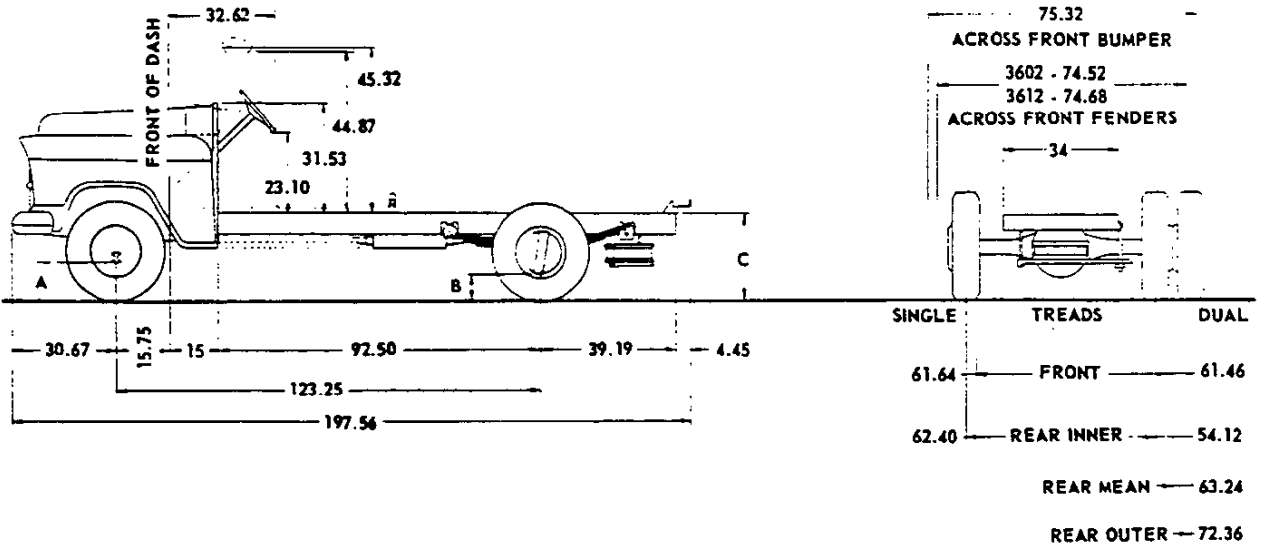

Equipment	Height Without Body and Payload			Tires	
	A	B	C	Front	Rear
Standard	8.80	7.43	27.02	15-6pr	15-6pr
Minimum for Max GVW	10.22	9.40	31.12	7.00-17-6pr x	7.50-17-8pr

VEHICLE WEIGHTS AND LOAD DISTRIBUTION

MODEL	WITH STANDARD EQUIPMENT						WITH MINIMUM EQUIPMENT FOR MAXIMUM GVW			
	Shipping			Curb			Body and Payload	Payload Distribution		Body Length
	Front	Rear	Total	Front	Rear	Total		Front	Rear	
3602 ●	1755	975	2730	1830	1080	2910	3875	Determined by style, length and weight of body		
3612 ●	1850	1010	2860	1925	1115	3040	3725			

3-25-55. Revised: 8-1-55. ●-Production weights replace estimated weights x-Data Revised.

CHASSIS AND BODY DIMENSIONS

MODEL 3603 CAB CHASSIS

MINIMUM GVW 5400 LBS.  
MAXIMUM GVW 6900 LBS.

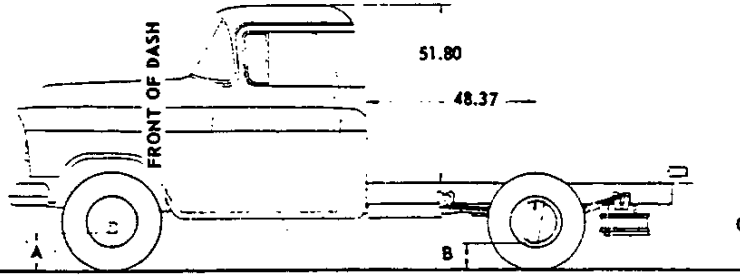

75.32  
ACROSS FRONT BUMPER  
75.03  
OVER CAB (WIDEST POINT)

74.68  
ACROSS  
FRONT FENDERS  
-- 34 --

	SINGLE	TREADS	DUAL
FRONT	61.64		61.46
INNER REAR	62.40		54.12
REAR MEAN			63.24
REAR OUTER			72.36

Equipment	Height Without Body and Payload			TIRES	
	A	B	C	Front	Rear
Standard	8.80	7.43	27.25	15-6pr	15-6pr
Minimum for Max GVW	10.22	9.40	30.50	7.00-17-6prx	7.50-17-8pr

MODEL 3604 PICKUP TRUCK

MINIMUM GVW 5400 LBS.  
MAXIMUM GVW 6900 LBS.

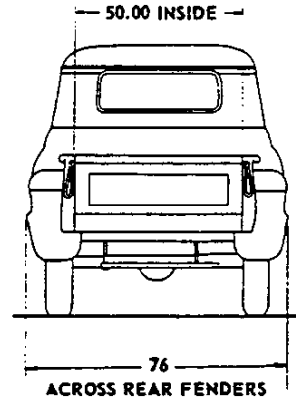
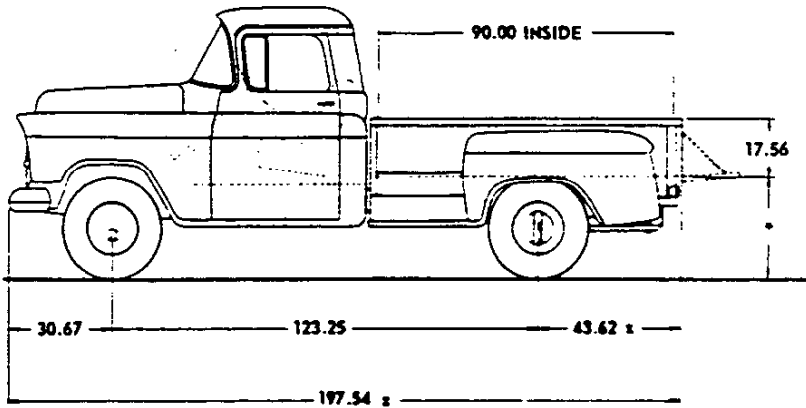

Equipment	* Platform Height		TIRES	
	Loaded	Unloaded	Front	Rear
Standard	26.15	29.51	15-6pr	15-6pr
Minimum for Max GVW	28.24	33.14	7.00-17-6pr	7.50-17-8pr

VEHICLE WEIGHTS AND LOAD DISTRIBUTION

MODEL	WITH STANDARD EQUIPMENT						WITH MINIMUM EQUIPMENT FOR MAXIMUM GVW			
	Shipping			Curb			Body and/or Payload	Payload Distribution		Body Length
	Front	Rear	Total	Front	Rear	Total		Front	Rear	
3603 ●	2035	1170	3205	2115	1275	3390	3375	8%	92%	72
								6%	94%	78
								3%	97%	84
								1%	99%	90
3604 ●	2070	1555	3625	2150	1660	3810	2950	1%	99%	90

3-25-55. Revised: 8-1-55. ●-Production weights replace estimated weights x-Data Revised.

72. MODELS 3603 AND 3604 DATA

CHEVROLET 1955 SPECIFICATIONS - TRUCK

### CHASSIS AND BODY DIMENSIONS

MODEL 3608 PLATFORM TRUCK

MINIMUM GVW 5400 LBS.  
MAXIMUM GVW 6900 LBS.

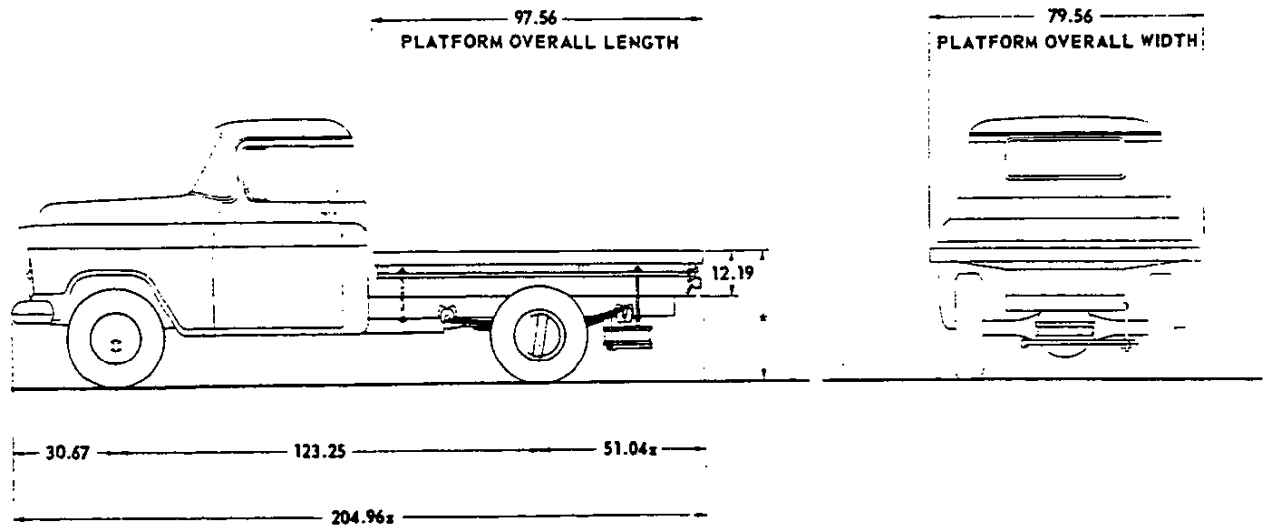

Equipment	* Platform Height		Tires	
	Loaded	Unloaded	Front	Rear
Standard	35.24	38.36	15-6pr.	15-6pr
Minimum for Max GVW	35.96	40.36	6.50-16-6pr	6.50-16-6pr Dual

MODEL 3609 STAKE TRUCK

MINIMUM GVW 5400 LBS.  
MAXIMUM GVW 6900 LBS.

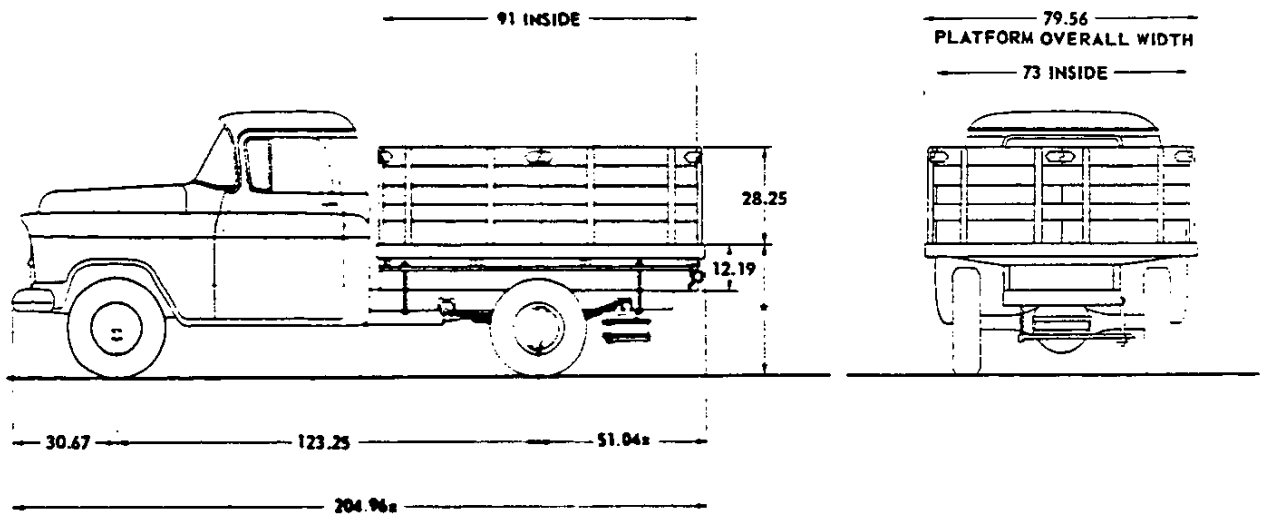

Equipment	* Platform Height		Tires	
	Loaded	Unloaded	Front	Rear
Standard	35.24	38.36	15-6pr	15-6pr
Minimum for Max GVW	35.96	40.36	6.50-16-6pr	6.50-16-6pr Dual

### VEHICLE WEIGHTS AND LOAD DISTRIBUTION

MODEL	WITH STANDARD EQUIPMENT						WITH MINIMUM EQUIPMENT FOR MAXIMUM GVW			
	Shipping			Curb			Payload	Payload Distribution		Body Length
	Front	Rear	Total	Front	Rear	Total		Front	Rear	
3608 ●	2015	1615	3630	2095	1720	3815	2940	0%	100%	97.56
3609 ●	2030	1785	3815	2110	1890	4000	2750	0%	100%	91.00

3-25-55. Revised. 8-1-55. ●-Production weights replace estimated weights x-Data Revised



### CHASSIS AND BODY DIMENSIONS

MODEL 3802 FLAT FACE COWL CHASSIS  
 MODEL 3812 WINDSHIELD COWL CHASSIS

MINIMUM GVW 6200 LBS.  
 MAXIMUM GVW 8800 LBS.

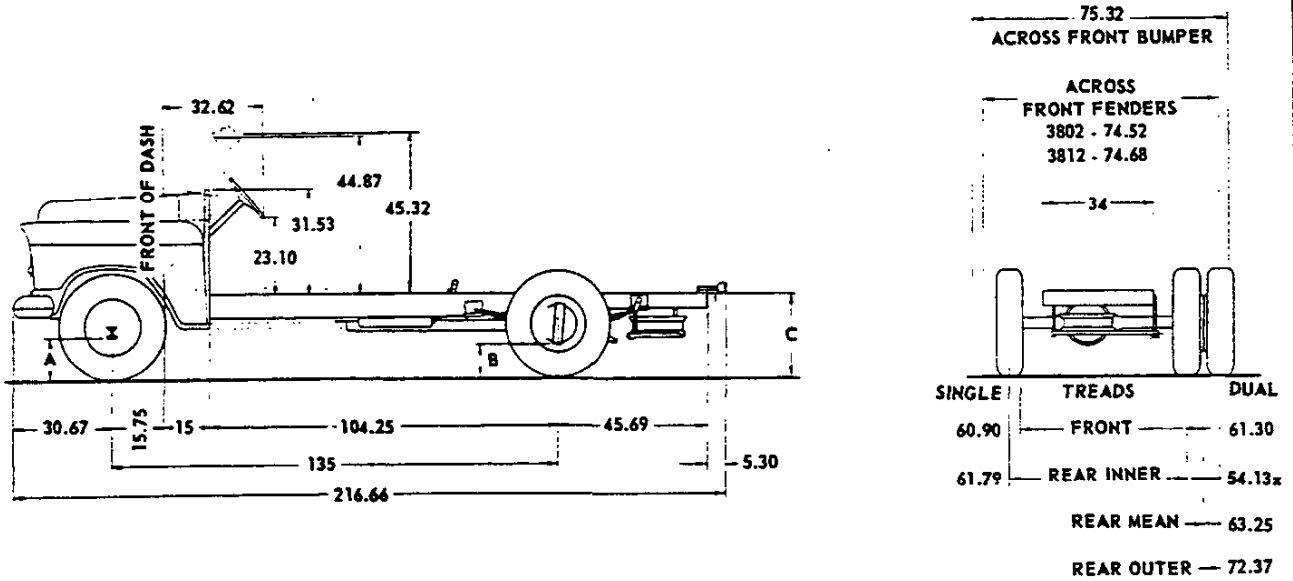

Equipment	Height Without Body and Payload			Tires	
	A	B	C	Front	Rear
Standard	10.22	8.85	30.00	7.00-17-6pr	7.00-17-8pr
Minimum for Max GVW	10.75	9.38	31.88	7.00-18-8pr	7.00-18-8pr Dual

### VEHICLE WEIGHTS AND LOAD DISTRIBUTION

MODEL	WITH STANDARD EQUIPMENT						WITH MINIMUM EQUIPMENT FOR MAXIMUM GVW			
	Shipping			Curb			Payload	Payload Distribution		Body Length
	Front	Rear	Total	Front	Rear	Total		Front	Rear	
3802 ●	1910	1140	3050	1970	1270	3240	5250	Determined by style, length and weight of body		
3812 ●	2005	1175	3180	2065	1305	3370	5100			

3-25-55. Revised: 8-1-55. ●-Production weights replace estimated weights x-Data Revised.

74 - MODELS 3802 AND 3812 DATA

CHEVROLET 1955 SPECIFICATIONS - TRUCK

CHASSIS AND BODY DIMENSIONS

MODEL 3803 CAB CHASSIS

MINIMUM GVW 6200 LBS.  
MAXIMUM GVW 8800 LBS.

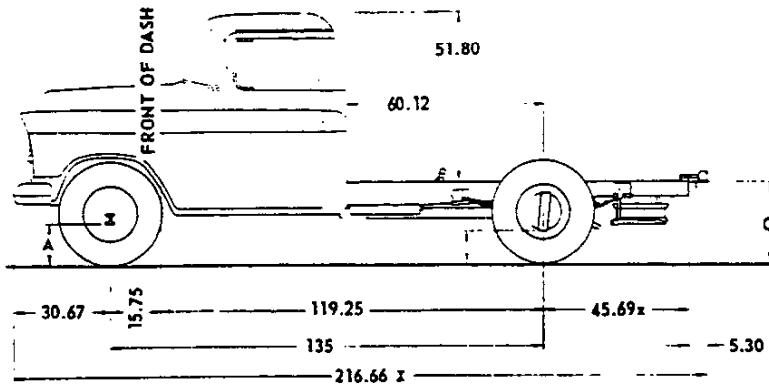

75.32  
ACROSS FRONT BUMPER

75.03  
OVER CAB  
(WIDEST POINT)  
74.68  
ACROSS  
FRONT FENDERS

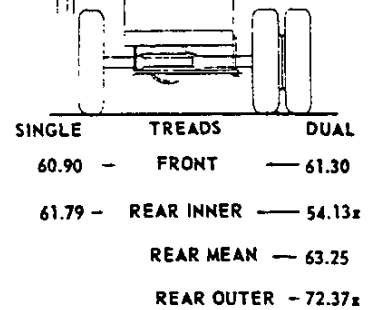

Equipment	Height Without Body and Payload			Tires	
	A	B	C	Front	Rear
Standard	10.22	8.85	29.88	7.00-17-6pr	7.00-17-8pr
Minimum for Max GVW	10.75	9.38	31.75	7.00-18-8pr	7.00-18-8pr Dual

MODEL 3804 PICKUP TRUCK

MINIMUM GVW 6200 LBS.  
MAXIMUM GVW 7000 LBS.

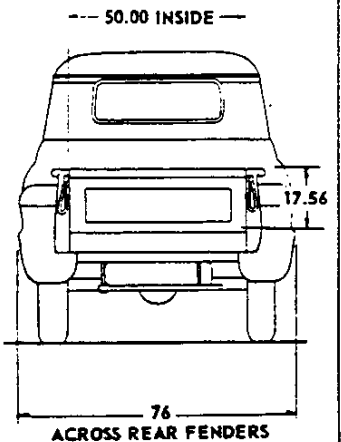
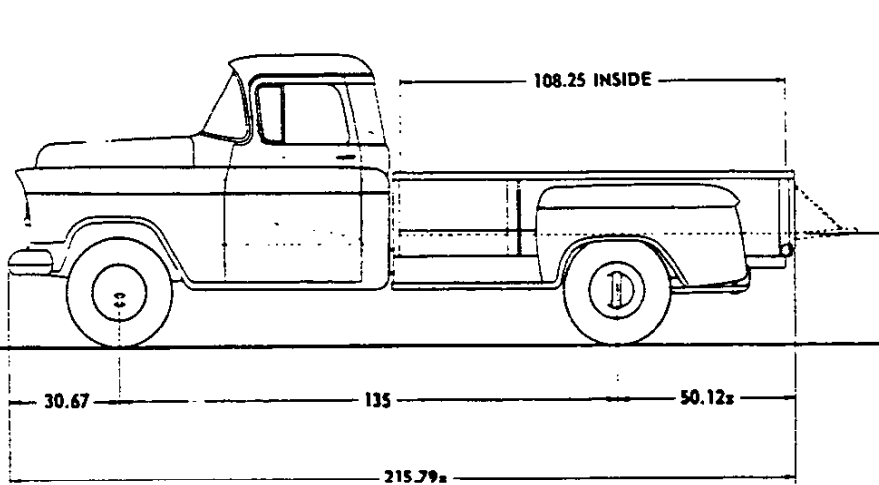

Equipment	* Platform Height		Tires	
	Loaded	Unloaded	Front	Rear
Standard	28.30	32.00	7.00-17-6pr	7.00-17-8pr
Minimum for Max GVW*	30.02	34.60	7.00-17-6pr	7.50-17-8pr

VEHICLE WEIGHTS AND LOAD DISTRIBUTION

MODEL	WITH STANDARD EQUIPMENT						WITH MINIMUM EQUIPMENT FOR MAXIMUM GVW				
	Shipping			Curb			Body and/or Payload	Payload Distribution		Body Length	
	Front	Rear	Total	Front	Rear	Total		Front	Rear		
3803 •	2230	1305	3535	2320	1410	3730	4750	7%	93%	96	
								5%	95%	102	
								3%	97%	108	
3804 •	2255	1730	3985	2345	1835	4180	2800	3%	97%	108.25	

3-25-55. Revised: 8-1-55, •-Production weights replace estimated weights x-Data Revised.

CHEVROLET 1955 SPECIFICATIONS - TRUCK

MODELS 3803 AND 3804 DATA - 75

CHASSIS AND BODY DIMENSIONS

MODEL 3805 PANEL TRUCK

MINIMUM GVW 6200 LBS.  
MAXIMUM GVW 7000 LBS.

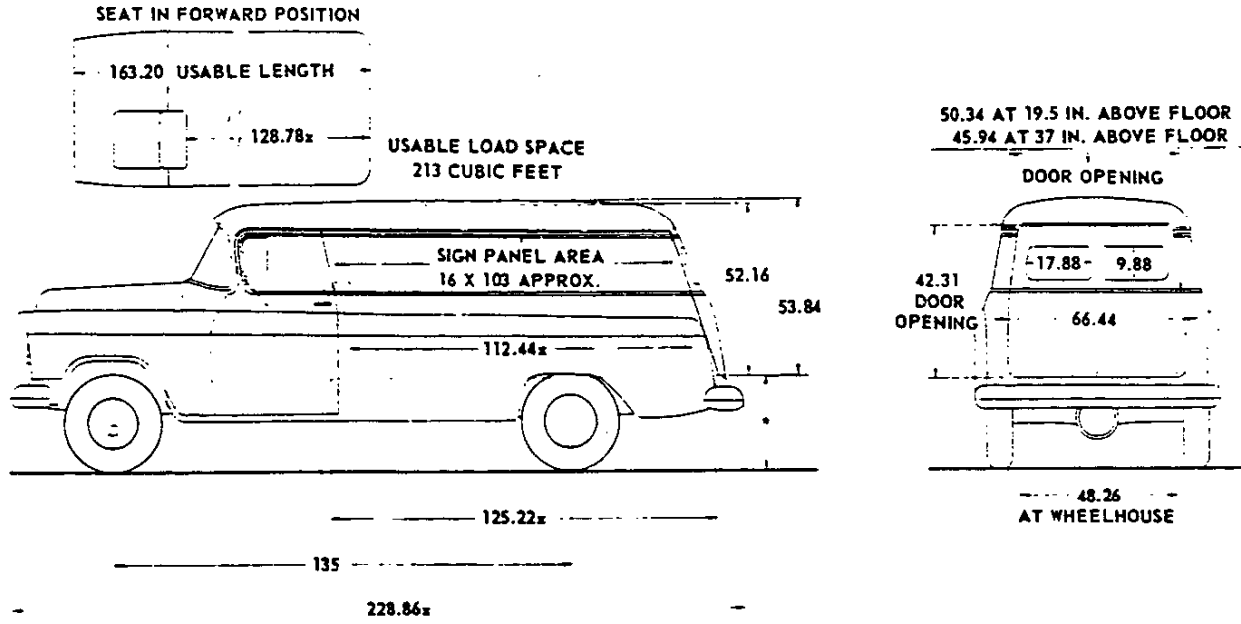

Equipment	Platform Height		Tires	
	Loaded	Unloaded	Front	Rear
Standard	28.37	31.34	7.00-17-6pr	7.00-17-8pr
Minimum for Max GVW	29.93	34.10	7.00-17-6pr	7.50-17-8pr

VEHICLE WEIGHT AND LOAD DISTRIBUTION

MODEL	WITH STANDARD EQUIPMENT						WITH MINIMUM EQUIPMENT FOR MAXIMUM GVW		
	Shipping			Curb			Payload	Payload Distribution	
	Front	Rear	Total	Front	Rear	Total		Front	Rear
3805 ●	2125	2175	4300	2185	2305	4490	2500	9%	91%

3-25-55. Revised: 8-1-55, ●-Production weights replace estimated weights x-Data Revised.

76 - MODEL 3805 DATA

CHEVROLET 1955 SPECIFICATIONS - TRUCK

### CHASSIS AND BODY DIMENSIONS

MODEL 3808 PLATFORM TRUCK

MINIMUM GVW 6200 LBS.  
MAXIMUM GVW 8800 LBS.

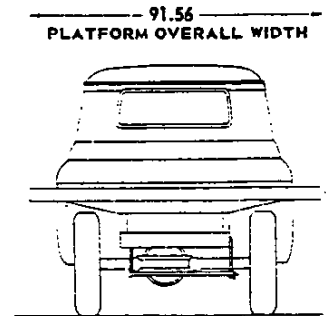
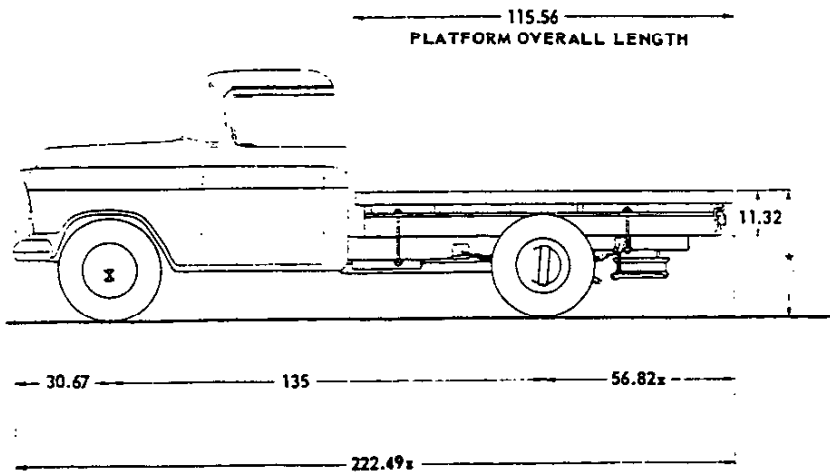

Equipment	Platform Height		Tires x	
	Loaded	Unloaded	Front	Rear
Standard	30.67	39.79	7.00-17-6pr	7.00-17-8pr
Minimum for Max GVW	38.11	42.20	7.00-18-8pr	7.00-18-8pr Dual

MODEL 3809 STAKE TRUCK

MINIMUM GVW 6200 LBS.  
MAXIMUM GVW 8800 LBS.

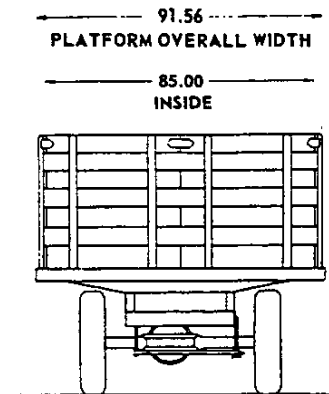
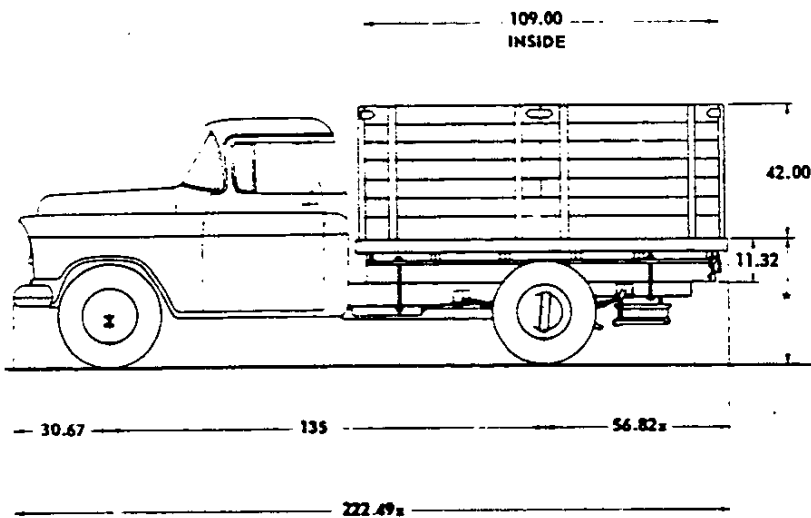

Equipment	Platform Height		Tires x	
	Loaded	Unloaded	Front	Rear
Standard	30.67	39.79	7.00-17-6pr	7.00-17-8pr
Minimum for Max GVW	38.11	42.20	7.00-18-8pr	7.00-18-8pr Dual

### VEHICLE WEIGHTS AND LOAD DISTRIBUTION

MODEL	WITH STANDARD EQUIPMENT						WITH MINIMUM EQUIPMENT FOR MAXIMUM GVW			
	Shipping			Curb			Payload	Payload Distribution		Body Length
	Front	Rear	Total	Front	Rear	Total		Front	Rear	
3808 •	2220	1855	4075	2310	1960	4270	4200	0%	100%	115.56
3809 •	2245	2115	4360	2335	2220	4555	3925	3%	97%	109.00

3-25-55. Revised: 8-1-55, •-Production weights replace estimated weights x-Data Revised.

CHASSIS AND BODY DIMENSIONS

MODEL 4102 FLAT FACE COWL CHASSIS  
MODEL 4112 WINDSHIELD COWL CHASSIS

MINIMUM GVW 10,000 LBS.  
MAXIMUM GVW 14,000 LBS.

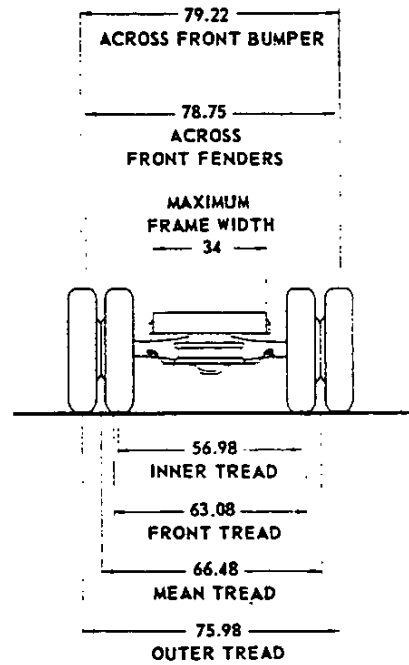
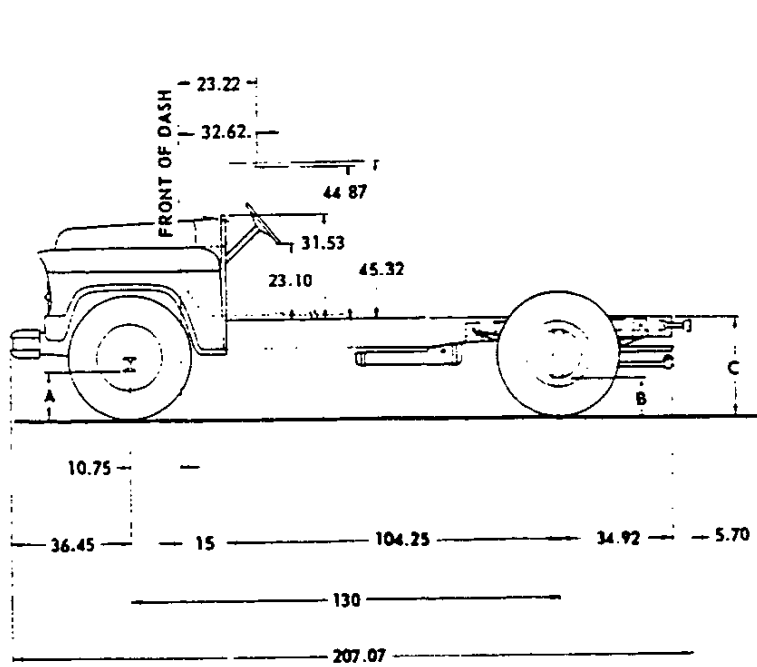

Equipment	Height Without Body and Payload			TIRES	
	A	B	C	Front	Rear
Standard	11.25	8.95	12.00	6.50-20-6pr	6.50-20-6pr Dual
Minimum for Max GVW	11.80	10.18	13.50	7.00-20-8pr	7.50-20-8pr Dual

VEHICLE WEIGHTS AND LOAD DISTRIBUTION

MODEL	WITH STANDARD EQUIPMENT						WITH MINIMUM EQUIPMENT FOR MAXIMUM GVW			
	Shipping			Curb			Payload	Payload Distribution		Body Length
	Front	Rear	Total	Front	Rear	Total		Front	Rear	
4102 e	2150	1590	3740	2225	1710	3935	9775	Determined by style, length and weight of body.		
4112 e	2245	1625	3870	2320	1745	4065	9665			

3-25-55. Revised: 8-1-55, e-Production weights replace estimated weights  
78 - MODELS 4102 AND 4112 DATA

CHEVROLET 1955 SPECIFICATIONS - TRUCK

CHASSIS AND BODY DIMENSIONS

MODEL 4103 CAB CHASSIS

MINIMUM GVW 10,000 LBS.  
MAXIMUM GVW 14,000 LBS.

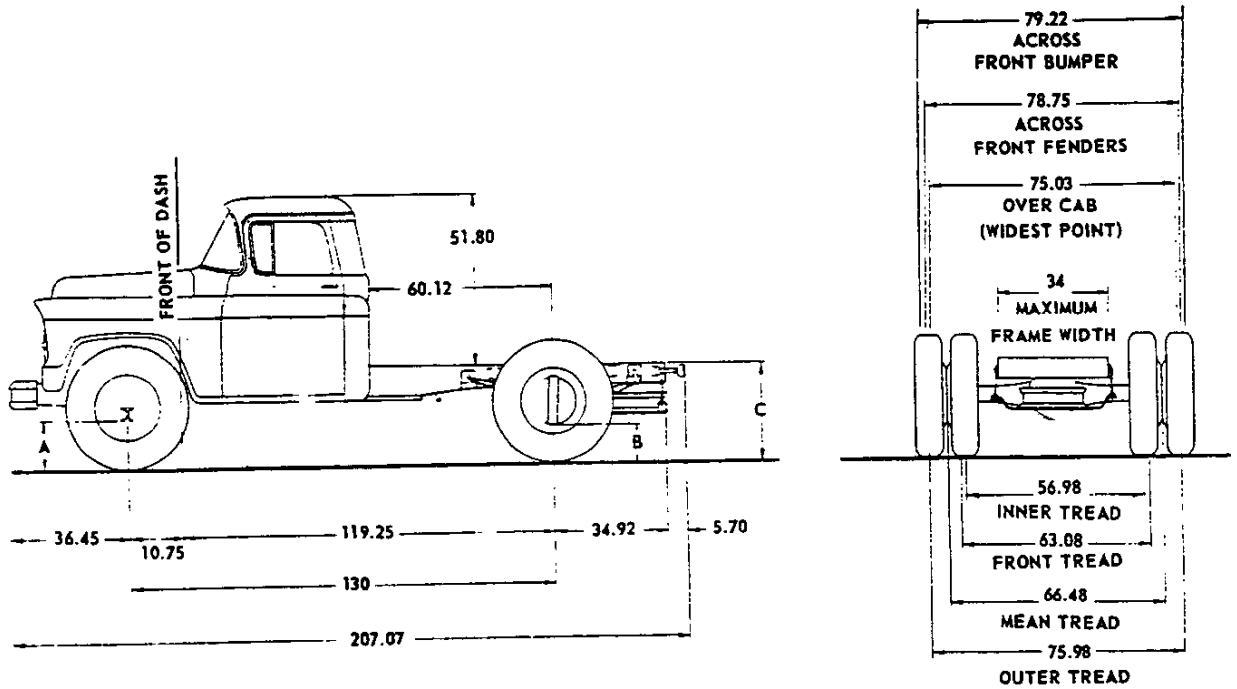

Equipment	Height Without Body and Payload			TIRES	
	A	B	C	Front	Rear
Standard	11.25	8.88	32.00	6.50-20-6pr	5.50-20-6pr Dual
Minimum for Max GVW	11.80	10.18	33.50	7.00-20-8pr	7.50-20-8pr Dual

VEHICLE WEIGHTS AND LOAD DISTRIBUTION

MODEL	WITH STANDARD EQUIPMENT						WITH MINIMUM EQUIPMENT FOR MAXIMUM GVW			
	Shipping			Curb			Body and Payload	Payload Distribution		Body Length
	Front	Rear	Total	Front	Rear	Total		Front	Rear	
4103 ●	2480	1770	4250	2565	1880	4445	9250	7%	93%	96
								5%	95%	102
								3%	97%	108

3-25-55. Revised: 8-1-55, ●-Production weights replace estimated weights  
CHEVROLET 1955 SPECIFICATIONS - TRUCK

MODEL 4103 DATA 79

### CHASSIS AND BODY DIMENSIONS

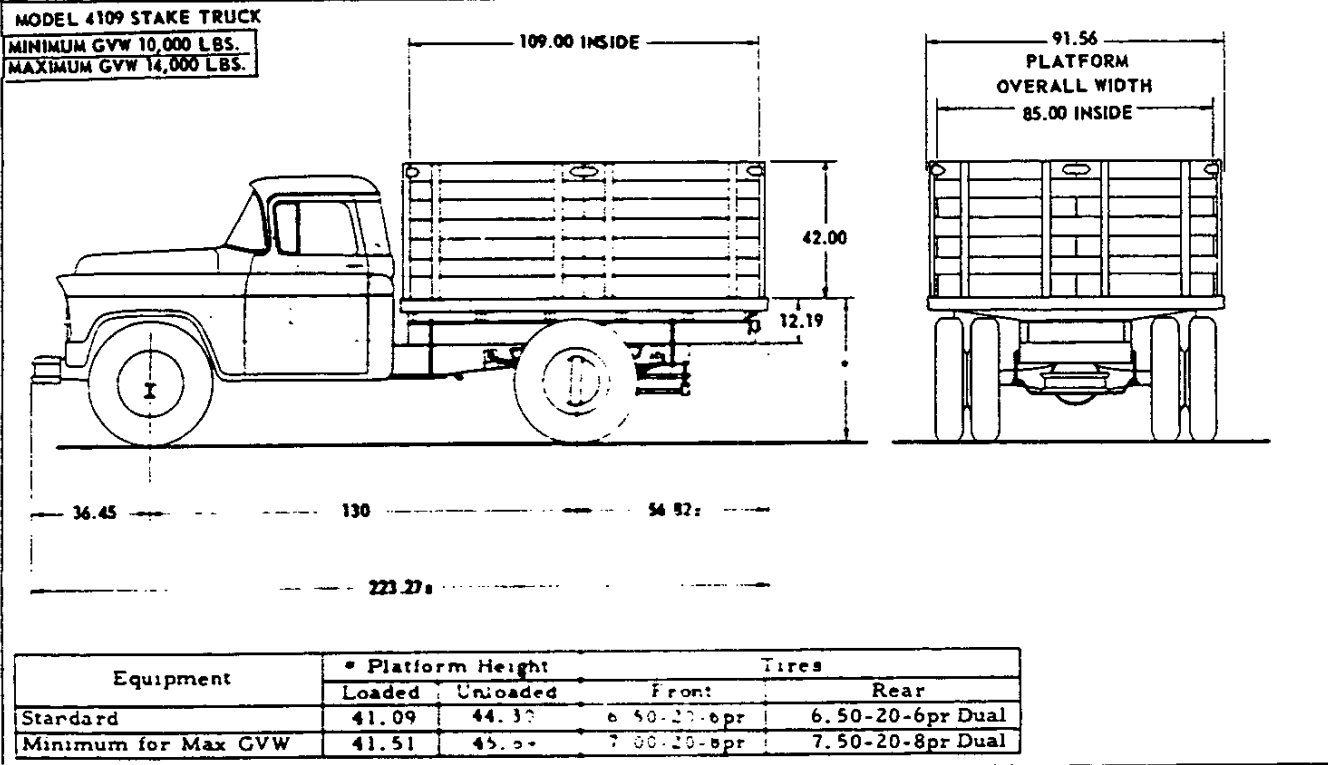
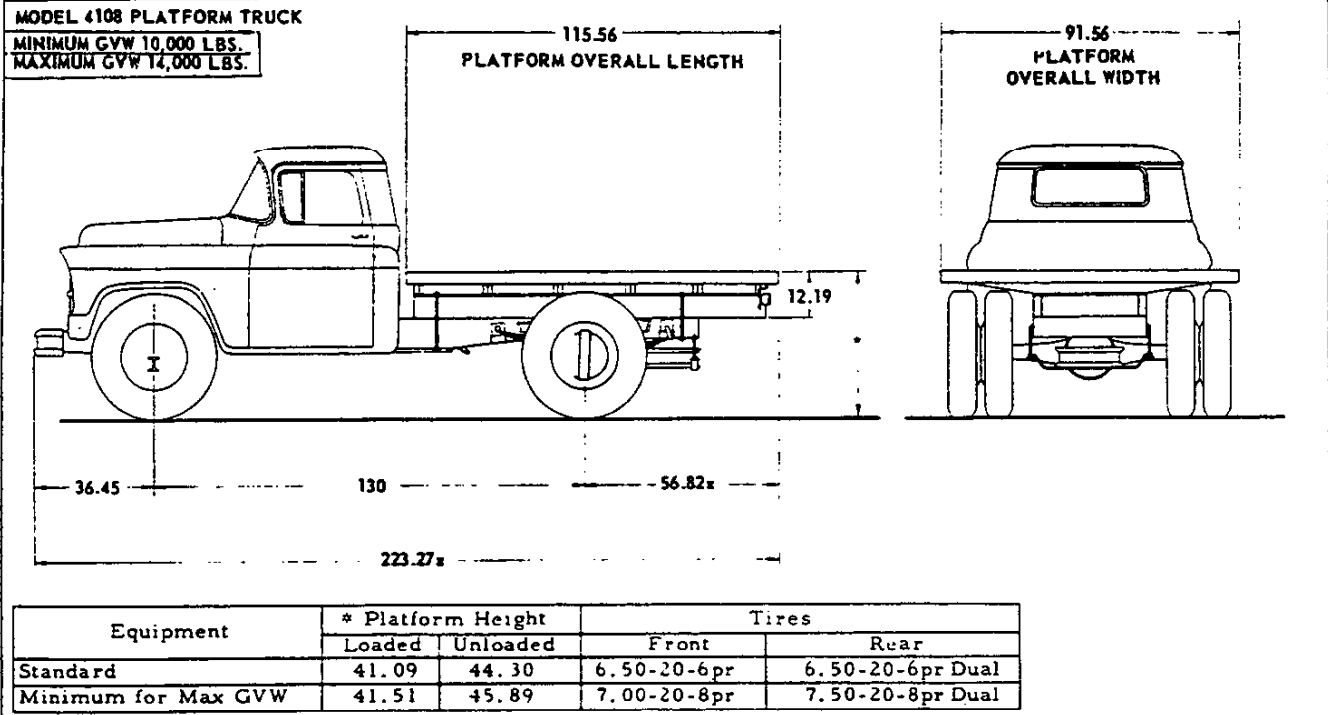

### VEHICLE WEIGHTS AND LOAD DISTRIBUTION

MODEL	WITH STANDARD EQUIPMENT						WITH MINIMUM EQUIPMENT FOR MAXIMUM GVW			
	Shipping			Curb			Payload	Payload Distribution		Body Length
	Front	Rear	Total	Front	Rear	Total		Front	Rear	
4108 •	2470	2340	4810	2555	2450	5005	8700	0%	100%	115.66
4109 •	2500	2565	5065	2585	2675	5260	8450	3%	97%	109.00

3-25-55. Revised: 8-1-55. •-Production weights replace estimated weights x-Data Revised.

80 - MODELS 4108 AND 4109 DATA

CHEVROLET 1955 SPECIFICATIONS - TRUCK

CHASSIS AND BODY DIMENSIONS

MODEL 4402 FLAT FACE COWL CHASSIS  
 MODEL 4412 WINDSHIELD COWL CHASSIS

MINIMUM GVW 10,000 LBS.  
 MAXIMUM GVW 14,000 LBS.

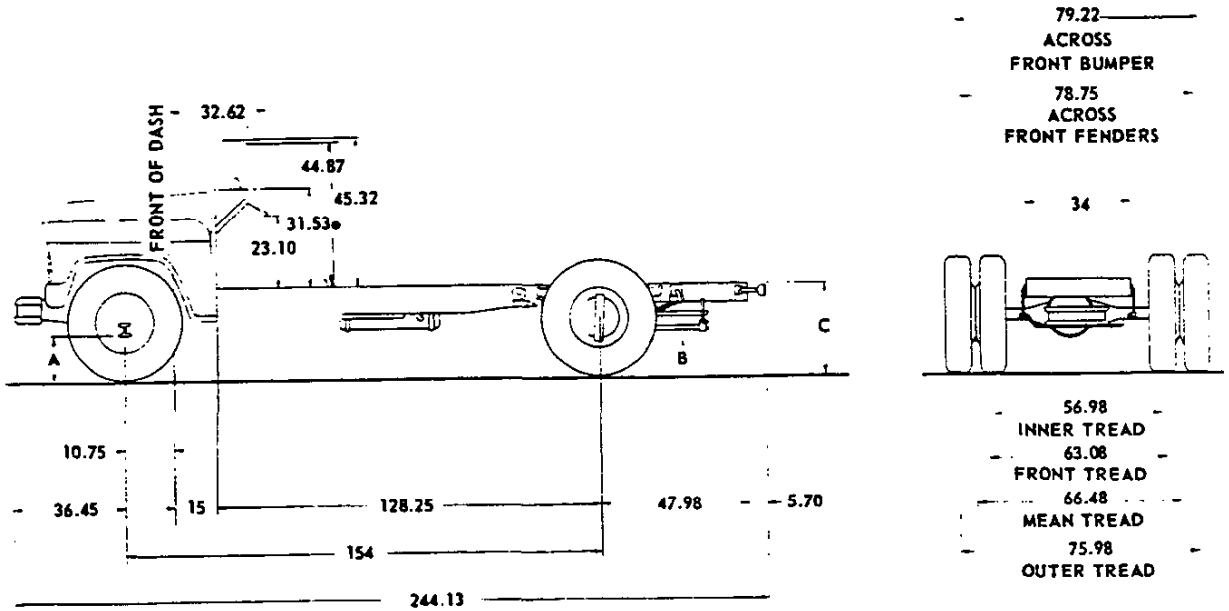

Equipment	Height without Body and Payload			Tires	
	A	B	C	Front	Rear
Standard	11.25	8.88	32.12	6.50-20-6pr	6.50-20-6pr Dual
Minimum for Max GVW	11.85	10.16	33.75	7.00-20-8pr	7.50-20-8pr Dual

VEHICLE WEIGHTS AND LOAD DISTRIBUTION

MODEL	WITH STANDARD EQUIPMENT						WITH MINIMUM EQUIPMENT FOR MAXIMUM GVW			
	Shipping			Curb			Body and Payload	Payload Distribution		Body Length
	Front	Rear	Total	Front	Rear	Total		Front	Rear	
4402 @	2160	1650	3810	2250	1775	4005	9700	Determined by style, length and weight of body.		
4412 @	2280	1660	3940	2370	1765	4135	9600			

@ Estimated Weight



CHASSIS AND BODY DIMENSIONS

MODEL 4403 CAB CHASSIS

MINIMUM GVW 10,000 LBS.  
MAXIMUM GVW 14,000 LBS.

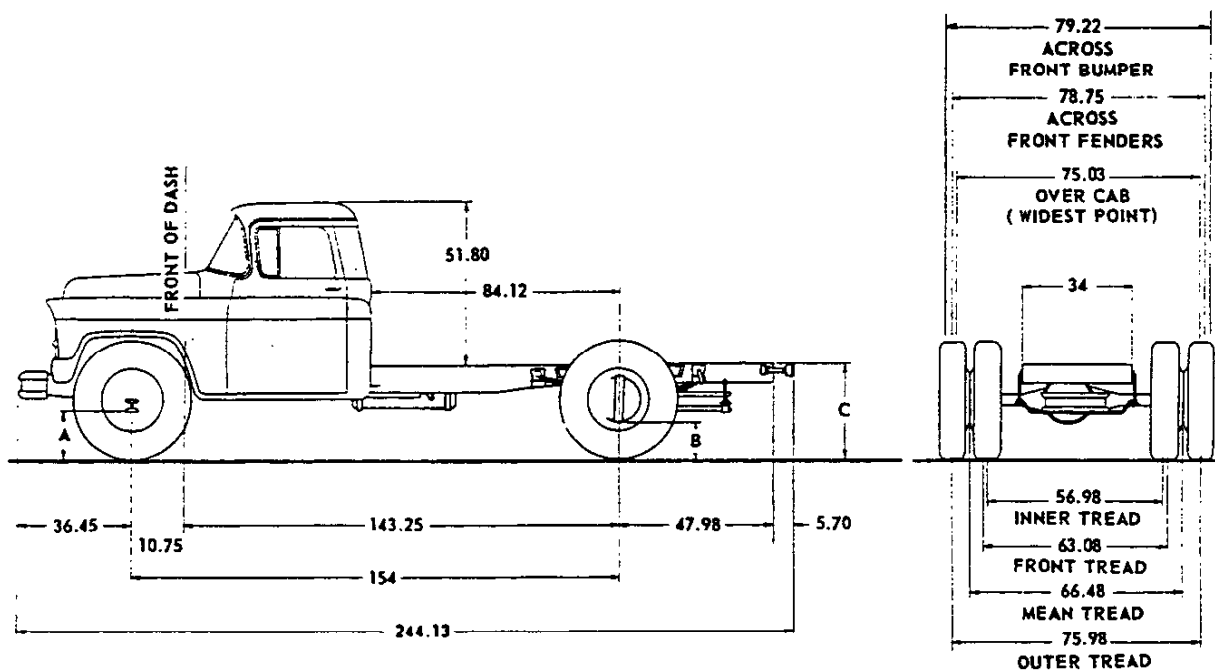

Equipment	Height Without Body and Payload			Tires	
	A	B	C	Front	Rear
Standard	11.25	8.88	32.25	6.50-20-6pr	6.50-20-6pr Dual
Minimum for Max GVW	11.80	10.18	33.75	7.00-20-8pr	7.50-20-8pr Dual

VEHICLE WEIGHTS AND LOAD DISTRIBUTION

MODEL	WITH STANDARD EQUIPMENT						WITH MINIMUM EQUIPMENT FOR MAXIMUM GVW			
	Shipping			Curb			Body and Payload	Payload Distribution		Body Length
	Front	Rear	Total	Front	Rear	Total		Front	Rear	
4403 ●	2575	1810	4385	2670	1910	4580	9125	14%	86%	120
								10%	90%	132
								6%	94%	144

3-25-55. Revised 8-1-55. ●-Production weights replace estimated weights  
82 - MODEL 4403 DATA

CHEVROLET 1955 SPECIFICATIONS - TRUCK

### CHASSIS AND BODY DIMENSIONS

**MODEL 4408 PLATFORM TRUCK**

**MINIMUM GVW 10,000 LBS.  
MAXIMUM GVW 14,000 LBS.**

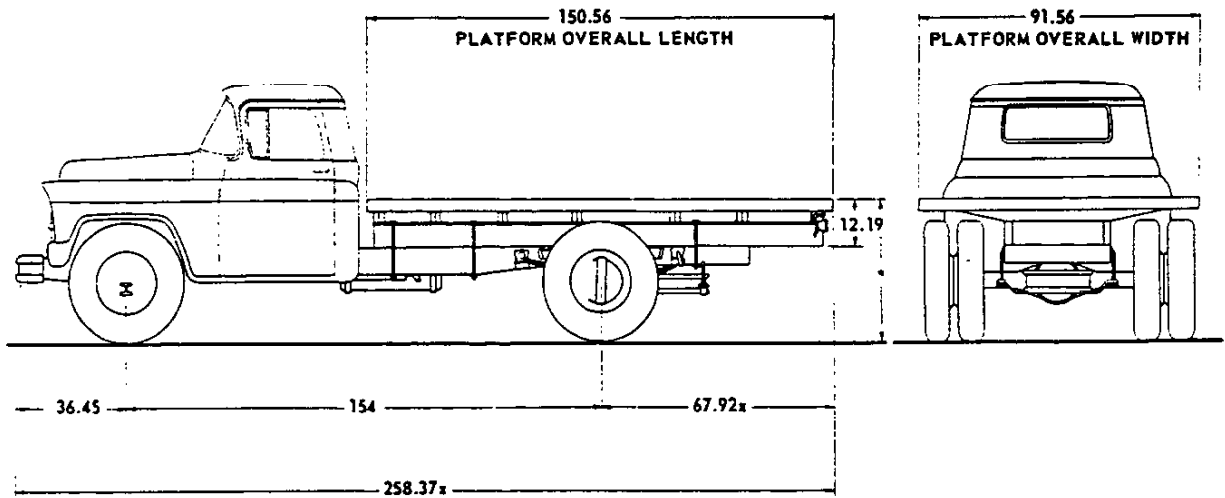

Equipment	Platform Height		Tires	
	Loaded	Unloaded	Front	Rear
Standard	41.31	44.31	6.50-20-6pr	6.50-20-6pr Dual
Minimum for Max GVW	41.71	45.98	7.00-20-8pr	7.50-20-8pr Dual

**MODEL 4409 STAKE TRUCK**

**MINIMUM GVW 10,000 LBS.  
MAXIMUM GVW 14,000 LBS.**

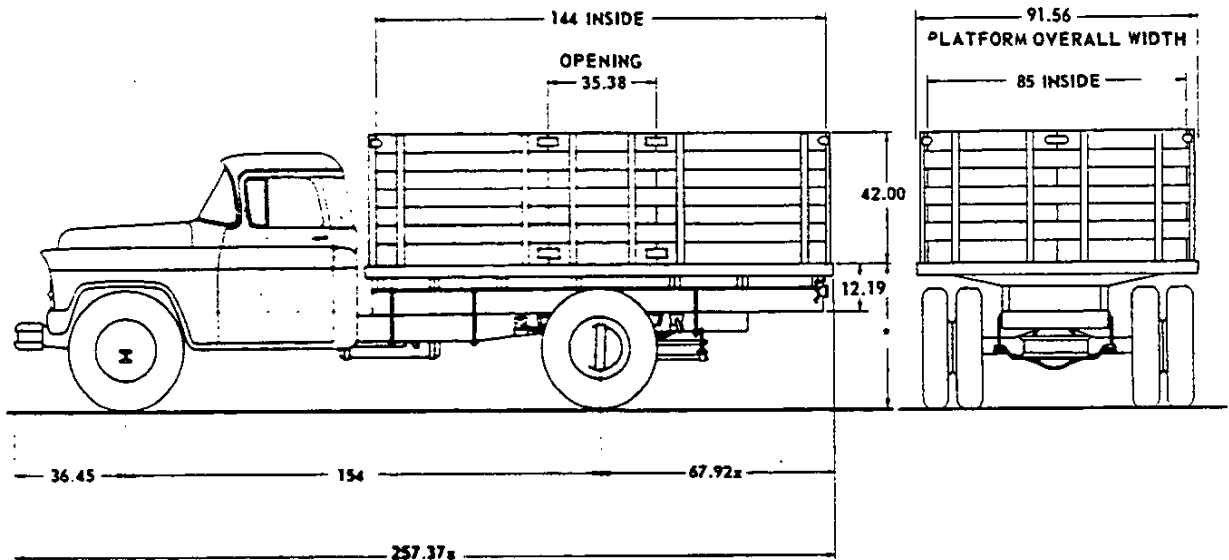

Equipment	Platform Height		Tires	
	Loaded	Unloaded	Front	Rear
Standard	41.31	44.31	6.50-20-6pr	6.50-20-6pr Dual
Minimum for Max GVW	41.71	45.98	7.00-20-8pr	7.50-20-8pr Dual

### VEHICLE WEIGHTS AND LOAD DISTRIBUTION

MODEL	WITH STANDARD EQUIPMENT						WITH MINIMUM EQUIPMENT FOR MAXIMUM GVW			
	Shipping			Curb			Payload	Payload Distribution		Body Length
	Front	Rear	Total	Front	Rear	Total		Front	Rear	
4408 ●	2600	2515	5115	2695	2615	5310	8400	5%	95%	150.56
4409 ●	2670	2750	5420	2765	2850	5615	8075	6%	94%	144.00

3-25-55. Revised: 8-1-55. ●-Production weights replace estimated weights x-Data Revised.

CHEVROLET 1955 SPECIFICATIONS - TRUCKS

MODELS 4408 AND 4409 DATA - 83

CHASSIS AND BODY DIMENSIONS

MODEL 4502 SCHOOL BUS FLAT FACE COWL CHASSIS

MINIMUM GVW 10,500 LBS.  
MAXIMUM GVW 12,000 LBS.

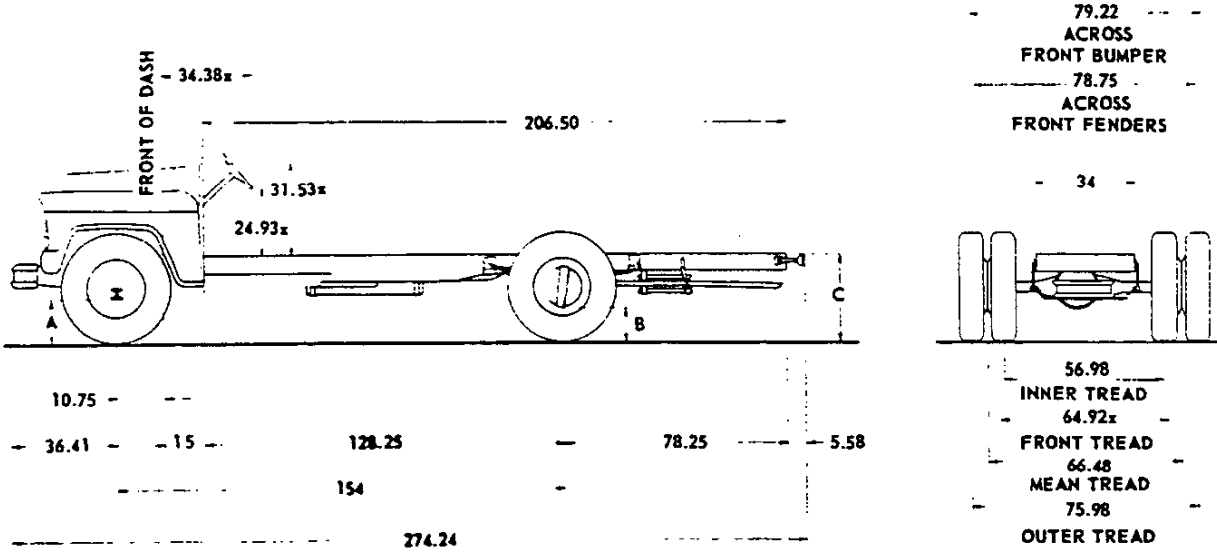

Equipment	Height Without Body and Payload			Tires	
	A	B	C	Front	Rear
Standard	10.81	8.91	34.12	6.50-20-6pr	6.50-20-6pr Dual
Minimum for Max GVW	10.81	9.42	35.12	6.50-20-6pr	7.00-20-8pr Dual

VEHICLE WEIGHTS AND LOAD DISTRIBUTION

MODEL	WITH STANDARD EQUIPMENT						WITH MINIMUM EQUIPMENT FOR MAXIMUM GVW			
	Shipping			Curb			Body and Payload	Payload Distribution		Body Length
	Front	Rear	Total	Front	Rear	Total		Front	Rear	
4502 ●	2205	1830	4035	2320	1985	4305	7650	Determined by style, length and weight of body		

3-25-55. Revised: 8-1-55, ●-Production weights replace estimated weights x-Data Revised.

84 - MODEL 4502 DATA

CHEVROLET 1955 SPECIFICATIONS - TRUCK

CHASSIS AND BODY DIMENSIONS

MODEL 5103 (5103S) L.C.F. CAB CHASSIS

MINIMUM GVW 14,000 LBS.  
MAXIMUM GVW 18,000 LBS.

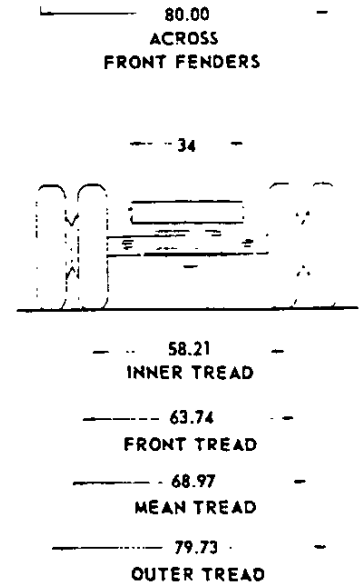
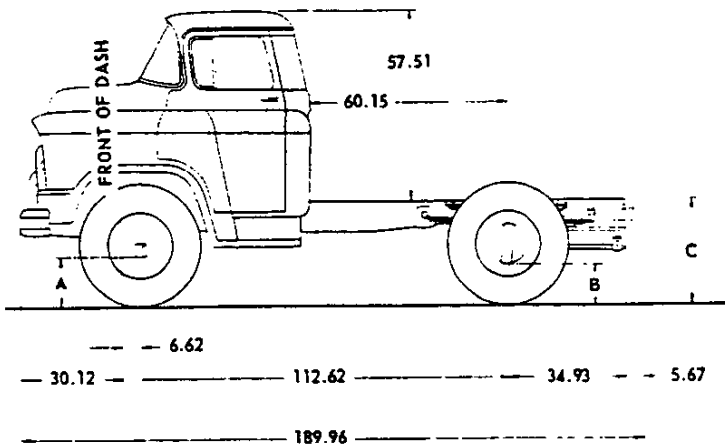

Equipment	Height Without Body and Payload			TIRES x	
	A	B	C	Front	Rear
Standard	12.32	9.30	33.22	7.50-20-8pr	7.50-20-8pr Dual
Minimum for Max GVW	12.82	10.10	35.00	8.25-20-11pr	8.25-20-12pr Dual

VEHICLE WEIGHTS AND LOAD DISTRIBUTION

MODEL	WITH STANDARD EQUIPMENT						WITH MINIMUM EQUIPMENT FOR MAXIMUM GVW			
	Shipping			Curb			Body and Payload	Payload Distribution		Body Length
	Front	Rear	Total	Front	Rear	Total		Front	Rear	
5103(S)e	2880	1930	4810	2980	2040	5020	12725	12%	88%	90
								9%	91%	96
								6%	94%	102
								4%	96%	108

3-25-55. Revised: 8-1-55. e-Production weights replace estimated weights x-Data Revised.

CHASSIS AND BODY DIMENSIONS

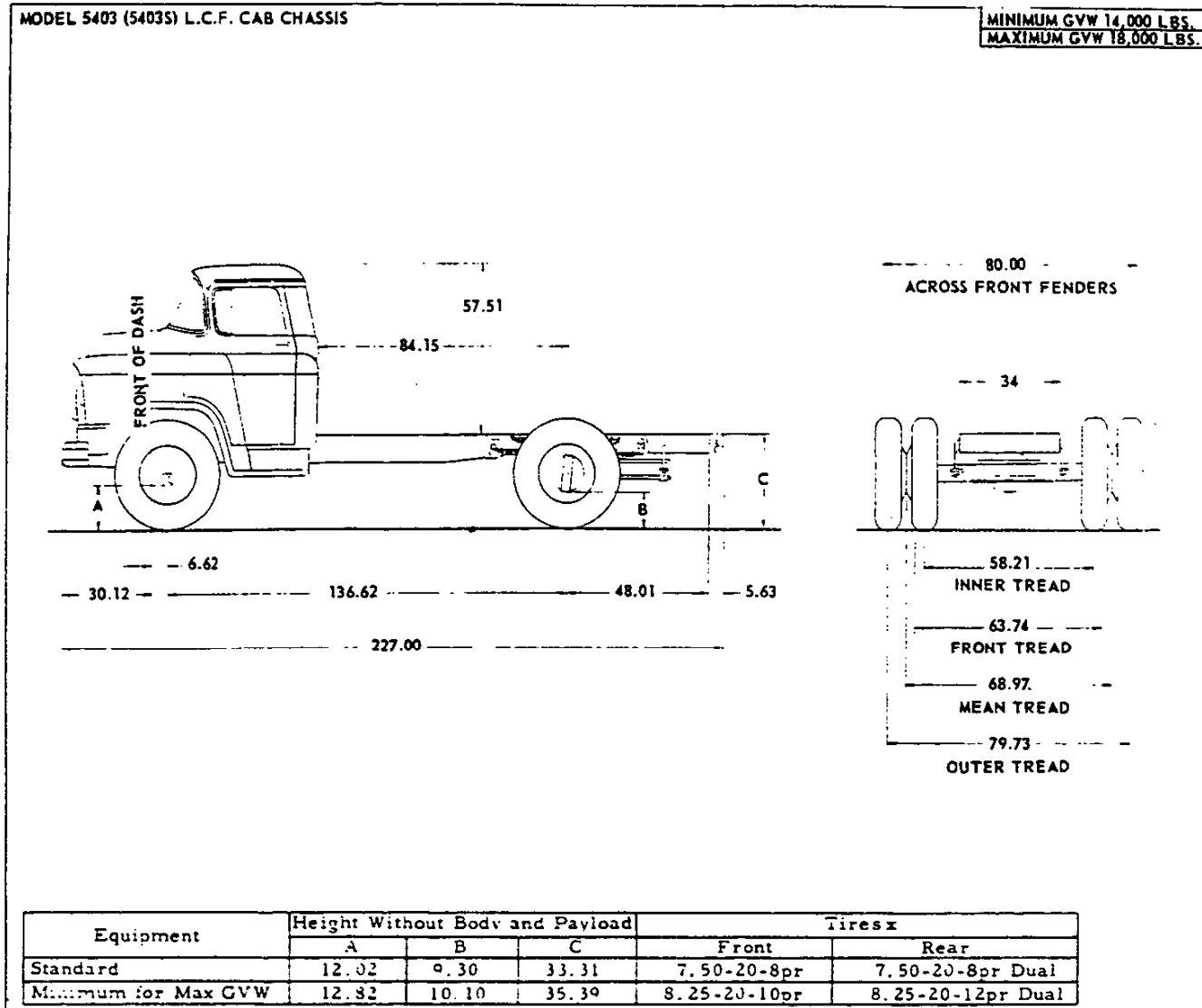

VEHICLE WEIGHTS AND LOAD DISTRIBUTION

MODEL	WITH STANDARD EQUIPMENT						WITH MINIMUM EQUIPMENT FOR MAXIMUM GVW			
	Shipping			Curb			Body and Payload	Payload Distribution		Body Length
	Front	Rear	Total	Front	Rear	Total		Front	Rear	
5403(S)●	2930	2000	4930	3040	2100	5140	12625	16%	84%	120
								12%	88%	132
								10%	90%	138
								8%	92%	144

3-25-55. Revised: 8-1-55. ●-Production weights replace estimated weights x-Data Revised.

CHASSIS AND BODY DIMENSIONS

MODEL 5408 (5408S) L.C.F. PLATFORM TRUCK  
 MINIMUM GVW 14,000 LBS.  
 MAXIMUM GVW 18,000 LBS.

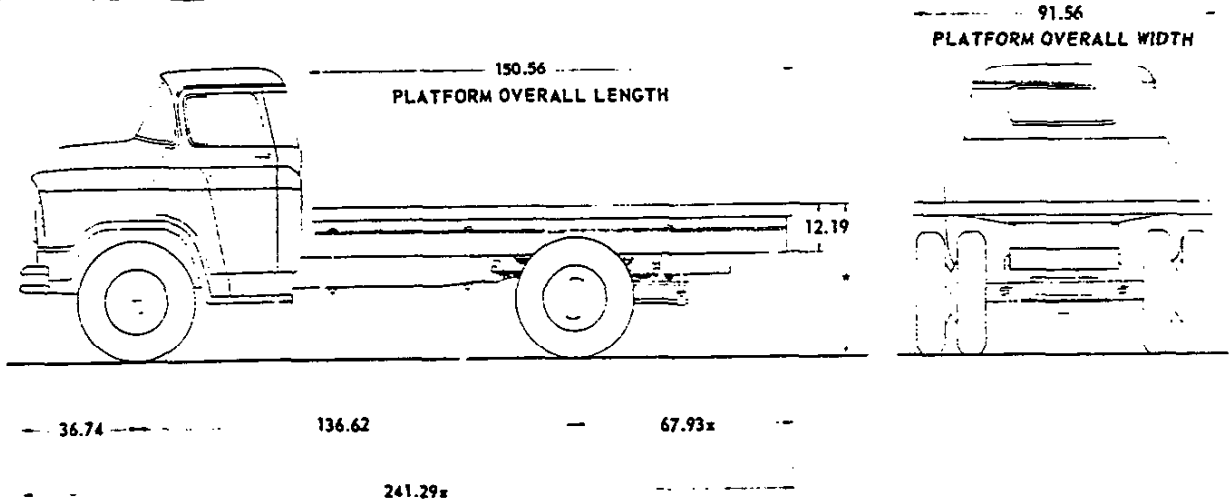

Equipment	* Platform Height		Tires	
	Loaded	Unloaded	Front	Rear
Standard	41.07	45.22	7.50-20-8pr	7.50-20-8pr Dual
Minimum for Max GVW	43.09	47.43	8.25-20-10pr	8.25-20-12 pr Dual

MODEL 5409 (5409S) L.C.F. STAKE TRUCK  
 MINIMUM GVW 14,000 LBS.  
 MAXIMUM GVW 18,000 LBS.

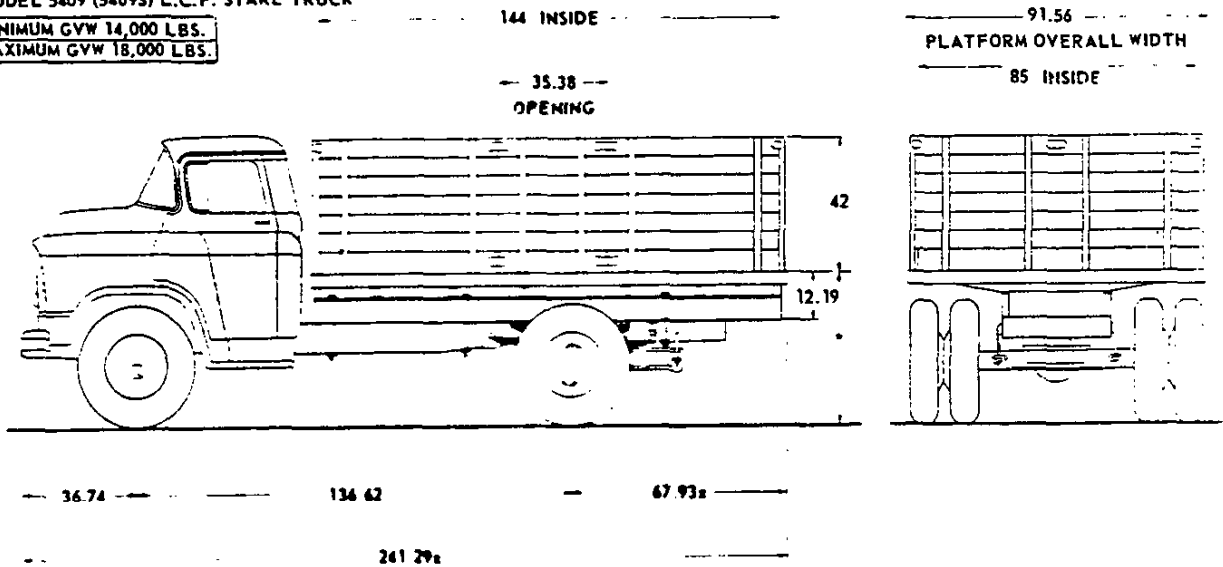

Equipment	* Platform Height		Tires	
	Loaded	Unloaded	Front	Rear
Standard	41.07	45.22	7.50-20-8pr	7.50-20-8pr Dual
Minimum for Max GVW	43.09	47.43	8.25-20-10 pr	8.25-20-12 pr Dual

VEHICLE WEIGHTS AND LOAD DISTRIBUTION

MODEL	WITH STANDARD EQUIPMENT						WITH MINIMUM EQUIPMENT FOR MAXIMUM GVW			
	Shipping			Curb			Payload	Payload Distribution		Body Length
	Front	Rear	Total	Front	Rear	Total		Front	Rear	
5408(S)•	2980	2635	5615	3090	2735	5825	11925	5%	95%	150.56
5409(S)•	3005	2925	5930	3115	3025	6140	11625	8%	92%	144.00

3-25-55. Revised: 8-1-55. •-Production weights replace estimated weights x-Data Revised.

CHEVROLET 1955 SPECIFICATIONS - TRUCK

MODELS 5408 (5408S) AND 5409 (5409S) DATA - 87

CHASSIS AND BODY DIMENSIONS

MODEL 5703 (5703S) L.C.F. CAB CHASSIS

MINIMUM GVW 14,000 LBS.  
MAXIMUM GVW 18,000 LBS.

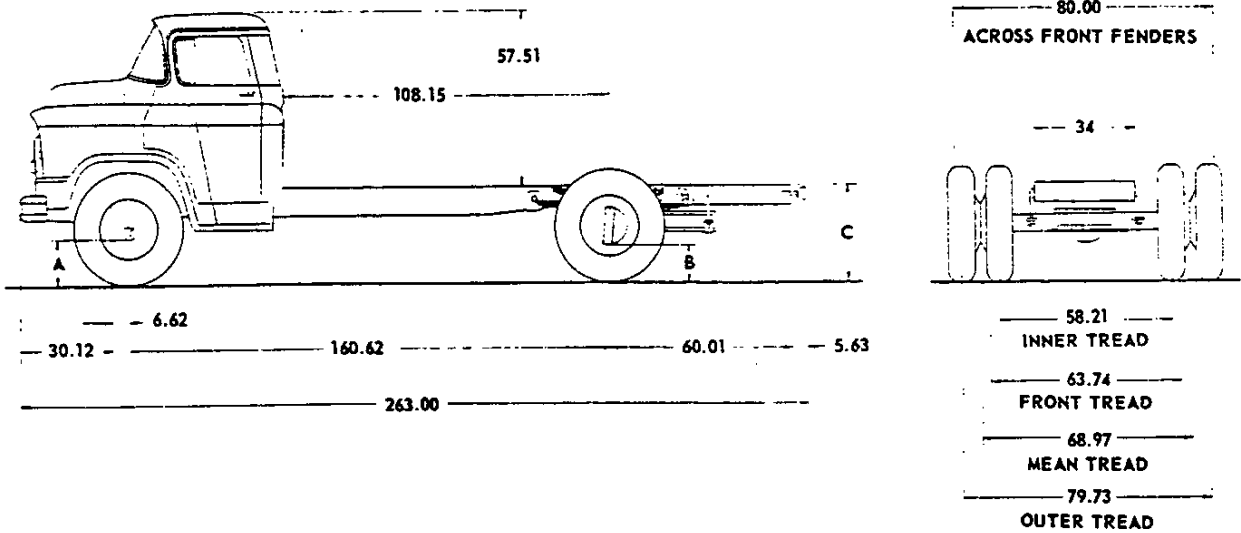

Equipment	Height Without Body and Payload			Tires x	
	A	B	C	Front	Rear
Standard	12.02	9.30	33.38	7.50-20-8 pr	7.50-20-8 pr Dual
Minimum for Max GVW	12.82	10.10	35.46	8.25-20-10 pr	8.25-20-12 pr Dual

VEHICLE WEIGHTS AND LOAD DISTRIBUTION

MODEL	WITH STANDARD EQUIPMENT						WITH MINIMUM EQUIPMENT FOR MAXIMUM GVW			Body Length
	Shipping			Curb			Body and Payload	Payload Distribution		
	Front	Rear	Total	Front	Rear	Total		Front	Rear	
5703(S) ●	2960	2050	5010	3075	2145	5220	12550	14%	86%	168
								10%	90%	180
								6%	94%	192

3-25-55. Revised: 8-1-55, ●-Production weights replace estimated weights x-Data Revised.

88 - MODEL 5703 (5703S) DATA

CHEVROLET 1955 SPECIFICATIONS - TRUCK

### CHASSIS AND BODY DIMENSIONS

MODEL 6102 (6102S) FLAT FACE COWL CHASSIS  
 MODEL 6112 (6112S) WINDSHIELD COWL CHASSIS

MINIMUM GVW 14,000 LBS.  
 MAXIMUM GVW 18,000 LBS.

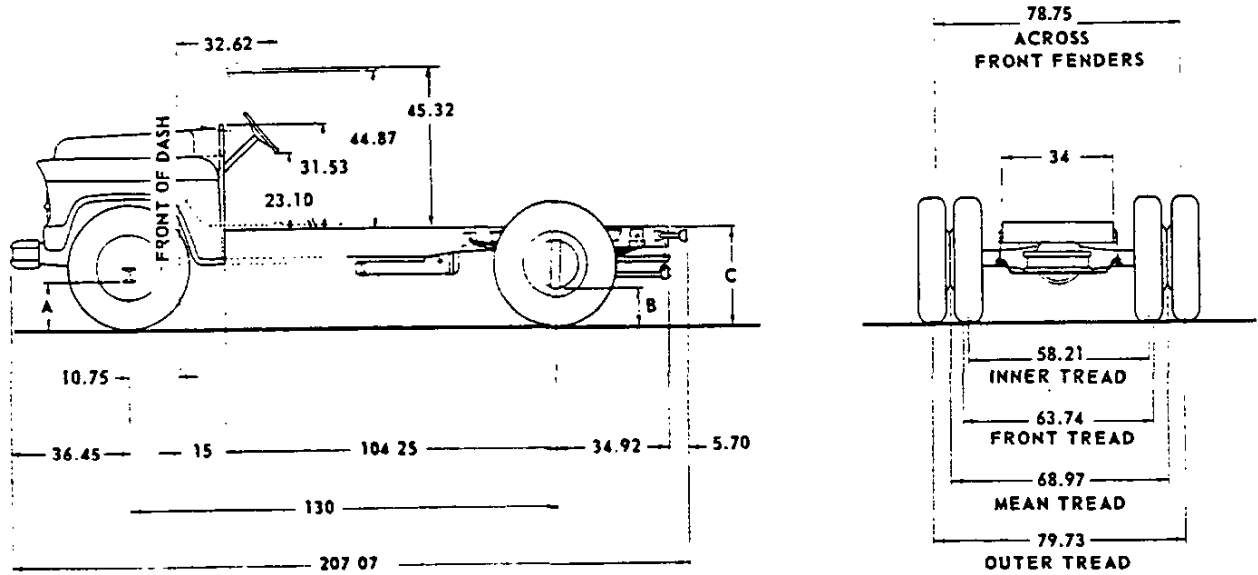

Equipment	Height Without Body and Payload			Tires	
	A	B	C	Front	Rear
Standard	12.02	4.74	33.75 <sup>⊕</sup>	7.50-20-8pr	7.50-20-8pr Dual
Minimum for Max GVW	12.62	10.34	35.62	8.25-20-10pr	8.25-20-12pr Dual

### VEHICLE WEIGHTS AND LOAD DISTRIBUTION

MODEL	WITH STANDARD EQUIPMENT						WITH MINIMUM EQUIPMENT FOR MAXIMUM GVW			
	Shipping			Curb			Body and Payload	Payload Distribution		Body Length
	Front	Rear	Total	Front	Rear	Total		Front	Rear	
6102(S) <sup>⊕</sup>	2190	1950	4140	2170	2085	4355	13350	Determined by style, length and weight of body.		
6112(S) <sup>⊕</sup>	2310	1955	4265	2190	2090	4480	13200			

<sup>⊕</sup> - Estimated Weight



### CHASSIS AND BODY DIMENSIONS

MODEL 6103 (6103S) CAB CHASSIS

MINIMUM GVW 14,000 LBS.  
MAXIMUM GVW 18,000 LBS.

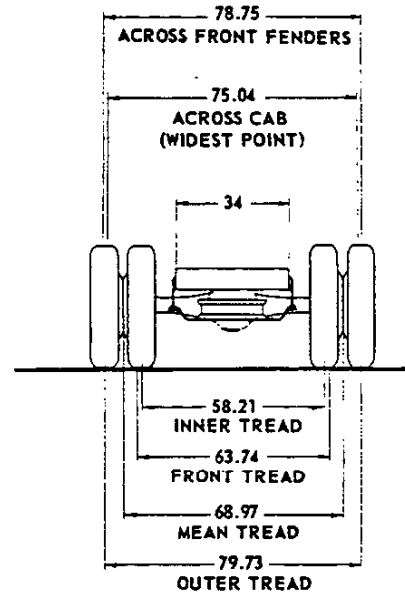
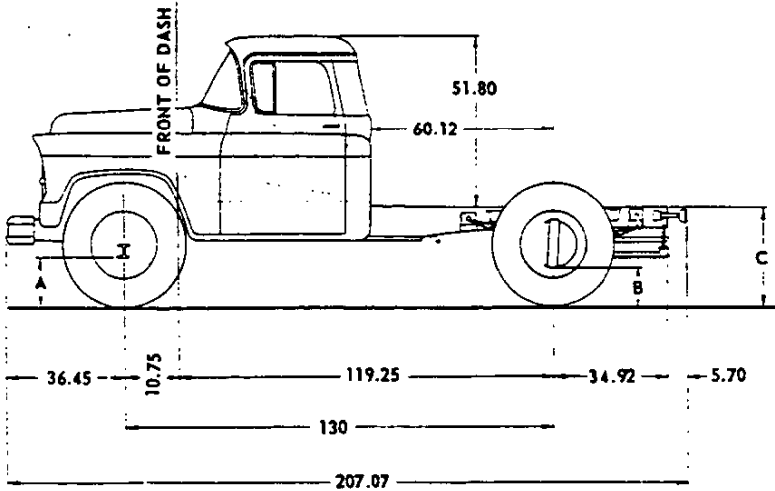

Equipment	Height Without Body and Payload			Tires	
	A	B	C	Front	Rear
Standard	12.02	9.74	33.75 x	7.50-20-8pr	7.50-20-8pr Dual
Minimum for Max GVW	12.62	10.34	35.62 x	8.25-20-10pr	8.25-20-12pr Dual

### VEHICLE WEIGHTS AND LOAD DISTRIBUTION

MODEL	WITH STANDARD EQUIPMENT						WITH MINIMUM EQUIPMENT FOR MAXIMUM GVW			
	Shipping			Curb			Body and Payload	Payload Distribution		Body Length
	Front	Rear	Total	Front	Rear	Total		Front	Rear	
6103(S) ●	2625	2060	4685	2715	2180	4895	12775	7%	93%	96
								5%	95%	102
								3%	97%	108

3-25-55. Revised: 8-1-55. ●-Production weights replace estimated weights x-Data Revised.

90 - MODEL 6103 (6103S) DATA

CHEVROLET 1955 SPECIFICATIONS -TRUCK

### CHASSIS AND BODY DIMENSIONS

**MODEL 6108 (6108S) PLATFORM TRUCK**

MINIMUM GVW 14,000 LBS.  
MAXIMUM GVW 18,000 LBS.

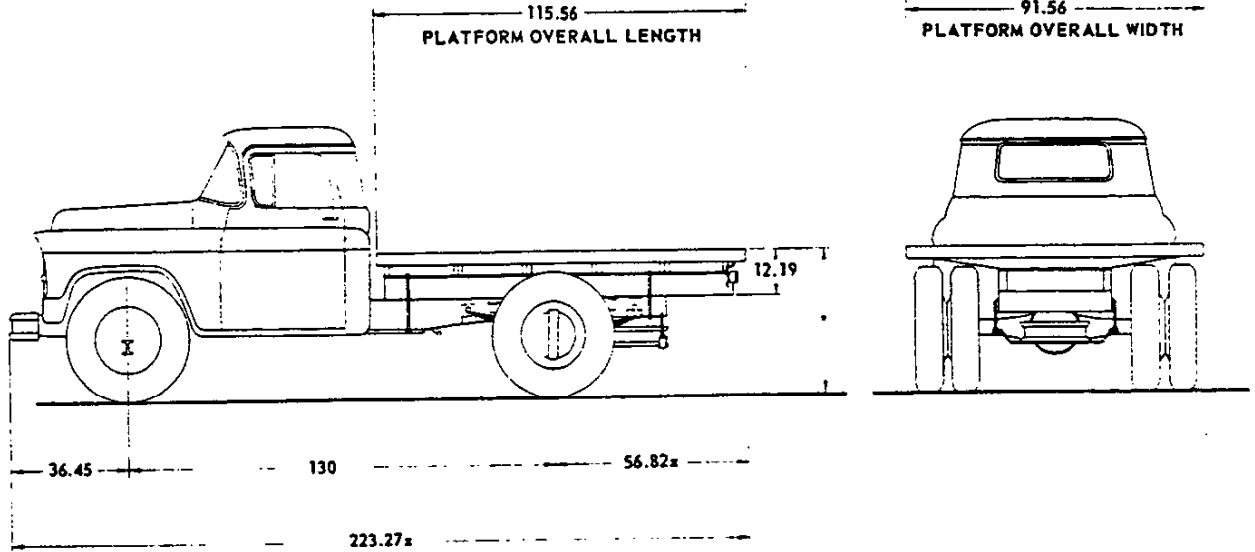

Equipment	Platform Height		Tires	
	Loaded	Unloaded	Front	Rear
Standard	42.15	46.23	7.50-20-8pr	7.50-20-8pr Dual
Minimum for Max GVW	43.90	48.23	8.25-20-10pr	8.25-20-12pr Dual

**MODEL 6109 (6109S) STAKE TRUCK**

MINIMUM GVW 14,000 LBS.  
MAXIMUM GVW 18,000 LBS.

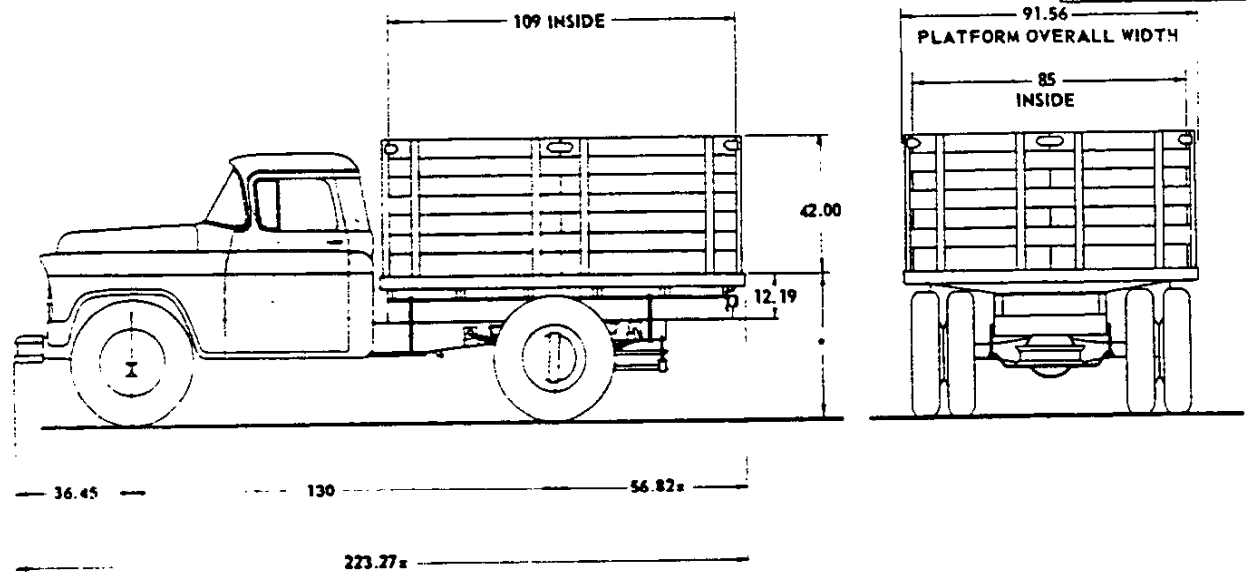

Equipment	Platform Height		Tires	
	Loaded	Unloaded	Front	Rear
Standard	42.15	46.23	7.50-20-8pr	7.50-20-8pr Dual
Minimum for Max GVW	43.90	48.23	8.25-20-10pr	8.25-20-12pr Dual

### VEHICLE WEIGHTS AND LOAD DISTRIBUTION

MODEL	WITH STANDARD EQUIPMENT						WITH MINIMUM EQUIPMENT FOR MAXIMUM GVW			
	Shipping			Curb			Payload	Payload Distribution		Body Length
	Front	Rear	Total	Front	Rear	Total		Front	Rear	
6108(S) ⊕	2490	2615	5115	2595	2730	5325	12350	0%	100%	115.56
6109(S) ⊕	2490	2885	5375	2585	3000	5585	12100	3%	97%	109.00

⊕ Estimated Weight

CHASSIS AND BODY DIMENSIONS

MODEL 6402 (6402S) FLAT FACE COWL CHASSIS  
 MODEL 6412 (6412S) WINDSHIELD COWL CHASSIS

MINIMUM GVW 14,000 LBS.  
 MAXIMUM GVW 18,000 LBS.

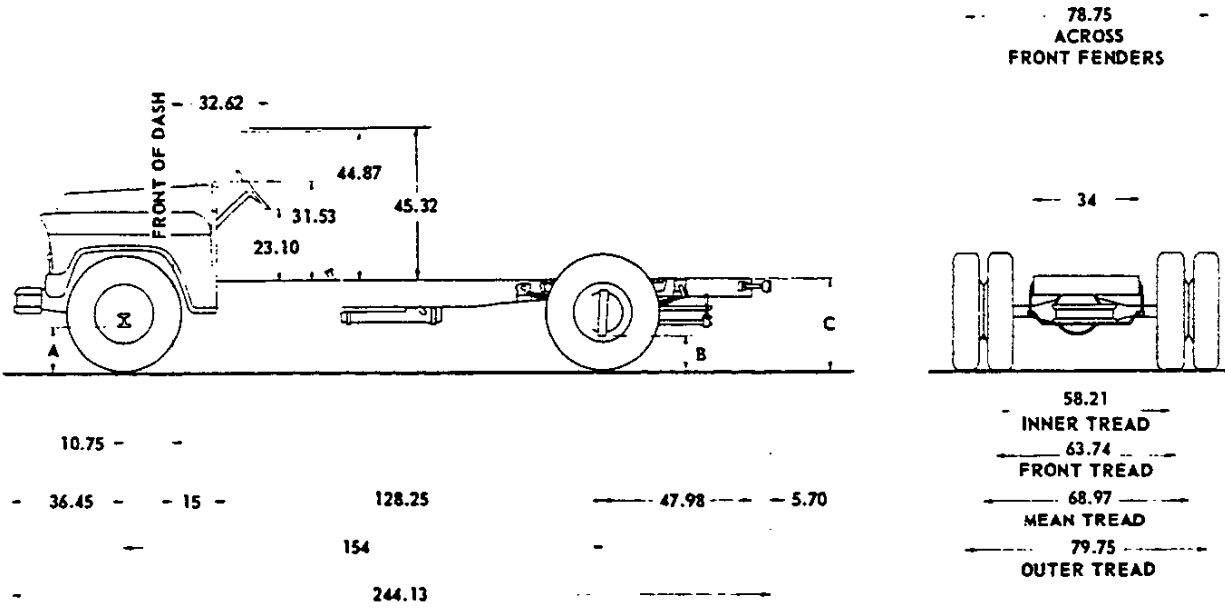

Equipment	Height Without Body and Payload			Tires	
	A	B	C	Front	Rear
Standard	12.02	9.74	33.87 x	7.50-20-8pr	7.50-20-8pr Dual
Minimum at Max GVW	12.62	10.34	35.88	8.25-20-10pr	8.25-20-12pr Dual

VEHICLE WEIGHTS AND LOAD DISTRIBUTION

MODEL	WITH STANDARD EQUIPMENT						WITH MINIMUM EQUIPMENT FOR MAXIMUM GVW			
	Shipping			Curb			Body and Payload	Payload Distribution		Body Length
	Front	Rear	Total	Front	Rear	Total		Front	Rear	
6402(S) ●	2280	1985	4265	2370	2110	4480	13200	Determined by style, length and weight of body.		
6412(S) ●	2315	2080	4395	2405	2205	4610	13075			

3-25-55. Revised: 8-1-55, ●-Production weights replace estimated weights x-Data Revised.

92 - MODELS 6402 (6402S) AND 6412 (6412S) DATA

CHEVROLET 1955 SPECIFICATIONS - TRUCK

CHASSIS AND BODY DIMENSIONS

MODEL 6403 (6403S) CAB CHASSIS

MINIMUM GVW 14,000 LBS.  
MAXIMUM GVW 18,000 LBS.

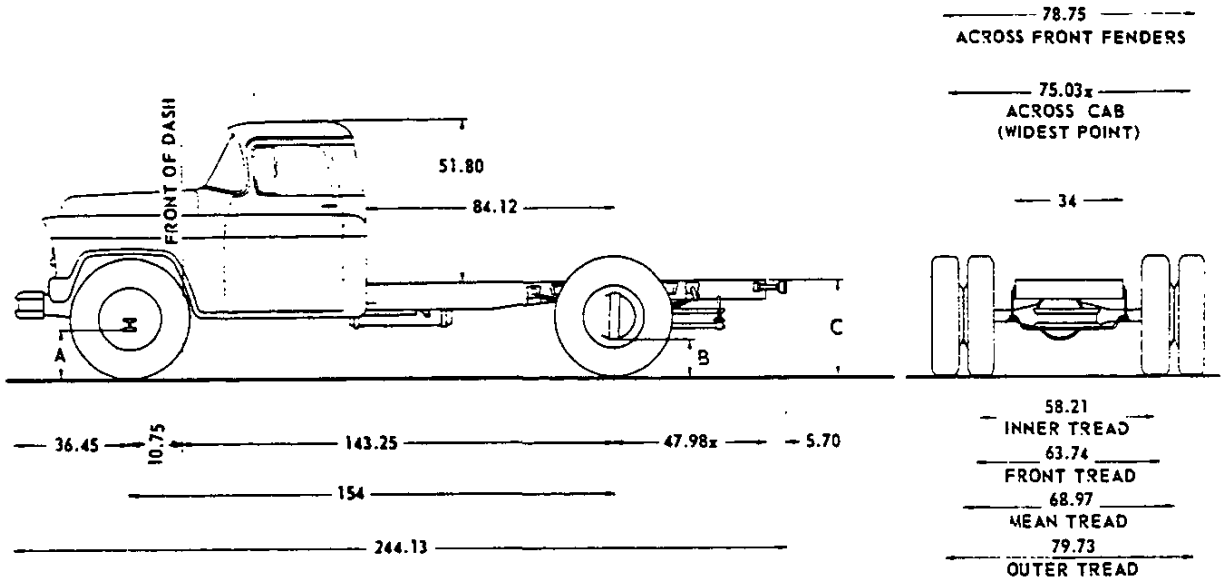

Equipment	Height Without Body and Payload			Tires	
	A	B	C	Front	Rear
Standard	12.02	9.74	33.87 x	7.50-20-8pr	7.50-20-8pr Dual
Minimum for Max GVW	12.62	10.34	35.89	8.25-20-10pr	8.25-20-12pr Dual

VEHICLE WEIGHTS AND LOAD DISTRIBUTION

MODEL	WITH STANDARD EQUIPMENT						WITH MINIMUM EQUIPMENT FOR MAXIMUM GVW			
	Shipping			Curb			Body and Payload	Payload Distribution		Body Length
	Front	Rear	Total	Front	Rear	Total		Front	Rear	
6403S) •	2695	2115	4810	2790	2230	5020	12650	14%	86%	120
								10%	90%	132
								6%	94%	144

3-25-55. Revised: 8-1-55, •-Production weights replace estimated weights x-Data Revised.

CHEVROLET 1955 SPECIFICATIONS - TRUCK

MODEL 6403 (6403S) DATA-93

### CHASSIS AND BODY DIMENSIONS

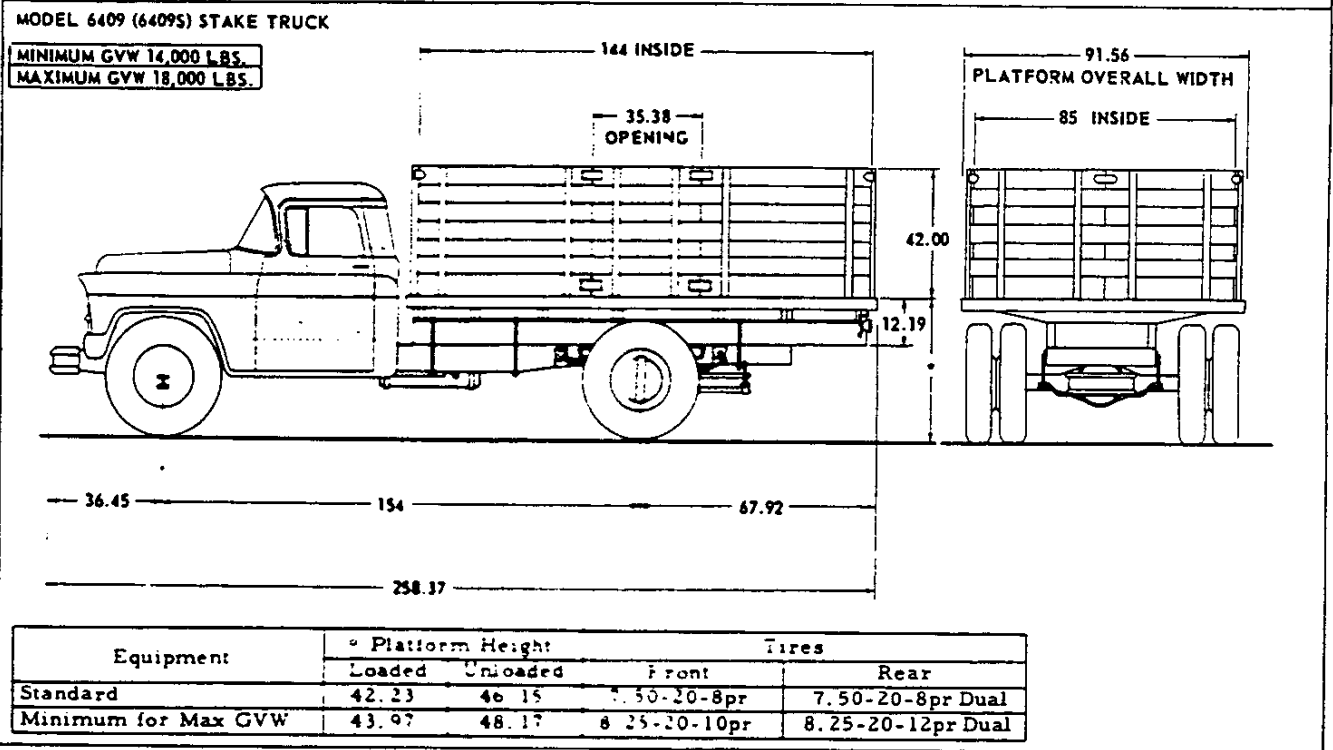
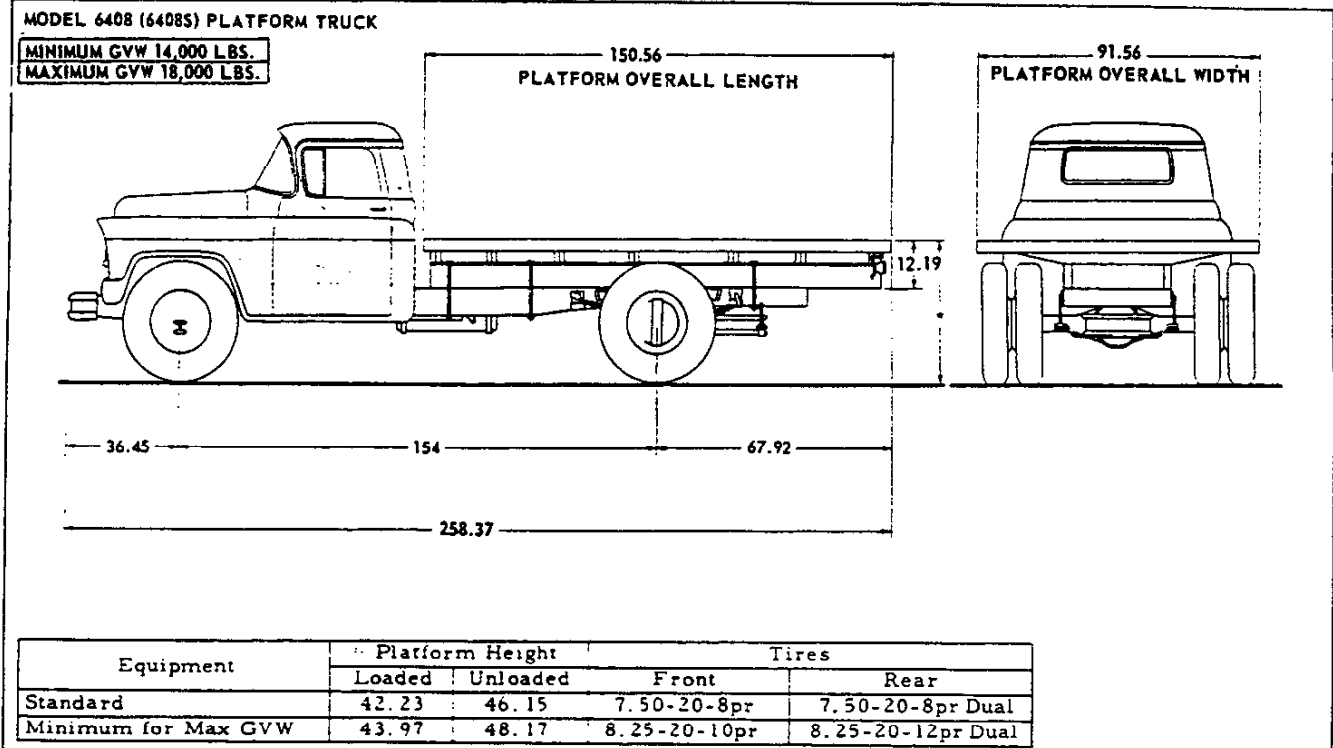

### VEHICLE WEIGHTS AND LOAD DISTRIBUTION

MODEL	WITH STANDARD EQUIPMENT						WITH MINIMUM EQUIPMENT FOR MAXIMUM GVW			
	Shipping			Curb			Payload	Payload Distribution		Body Length
	Front	Rear	Total	Front	Rear	Total		Front	Rear	
6408(S) ●	2695	2770	5465	2790	2885	5675	12000	5%	95%	150.56
6409(S) ●	2790	3090	5880	2885	3205	6090	11575	6%	94%	144.00

3-25-55. Revised: 8-1-55, ●-Production weights replace estimated weights  
 94 - MODELS 6408 (6408S) AND 6409 (6409S) DATA

CHEVROLET 1955 SPECIFICATIONS - TRUCK

CHASSIS AND BODY DIMENSIONS

MODEL 6502 (6502S) FLAT FACE COWL CHASSIS  
 MODEL 6512 (6512S) WINDSHIELD COWL CHASSIS

MINIMUM GVW 14,000 LBS.  
 MAXIMUM GVW 18,000 LBS.

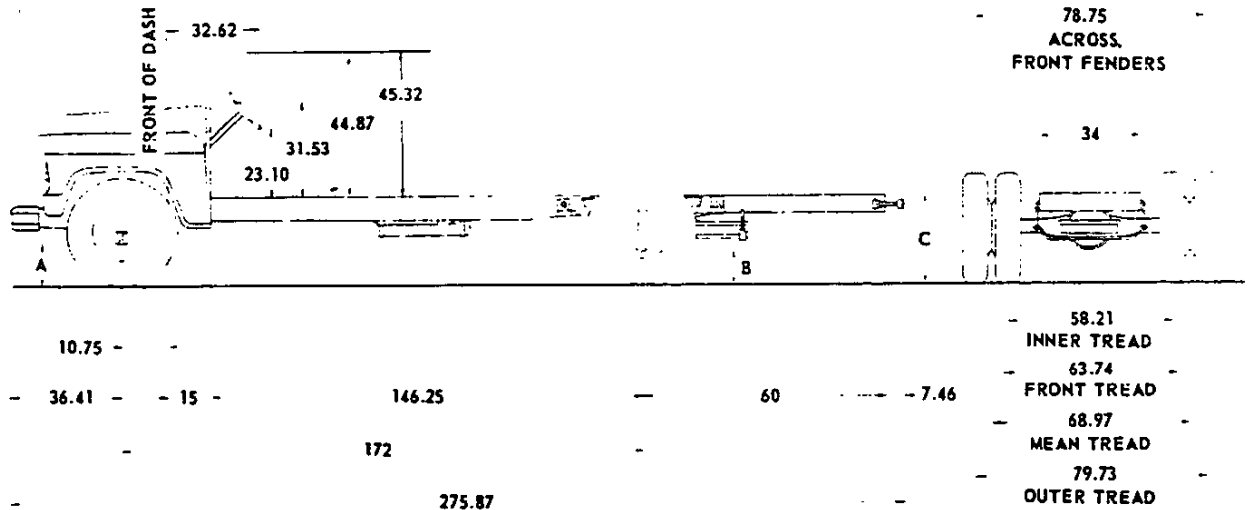

Equipment	Height Without Body and Payload			Tires	
	A	B	C	Front	Rear
Standard	12.02	9.74	34.01	7.50-20-8 pr	7.50-20-8 pr Dual
Minimum for Max GVW	12.62	10.34	35.67	8.25-20-10 pr	8.25-20-12 pr Dual

VEHICLE WEIGHTS AND LOAD DISTRIBUTION

MODEL	WITH STANDARD EQUIPMENT						WITH MINIMUM EQUIPMENT FOR MAXIMUM GVW			
	Shipping			Curb			Body and Payload	Payload Distribution		Body Length
	Front	Rear	Total	Front	Rear	Total		Front	Rear	
6502(S) Ⓞ	2265	2090	4355	2360	2210	4570	13100	Determined by style, length and weight of body		
6512 (S) Ⓞ	2360	2120	4480	2455	2240	4695	13000			

Ⓞ - Estimated Weight

CHASSIS AND BODY DIMENSIONS

MODEL 6503 (6503S) CAB CHASSIS

MINIMUM GVW 14,000 LBS.  
MAXIMUM GVW 18,000 LBS.

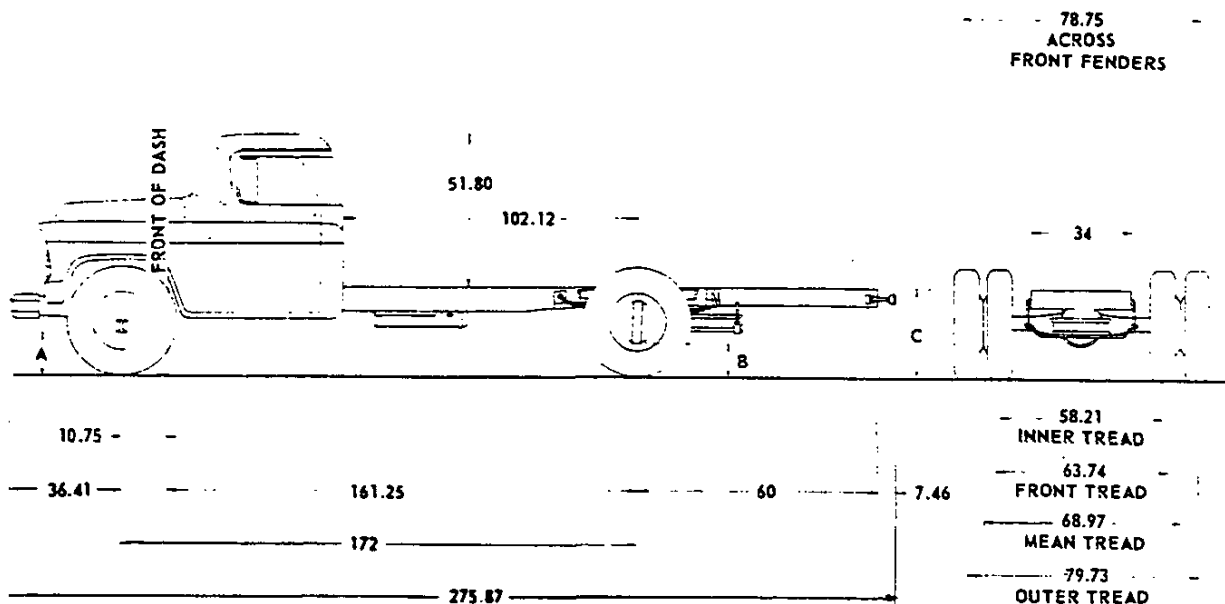

Equipment	Height Without Body and Payload			Tires	
	A	B	C	Front	Rear
Standard	12.02	2.74	34.00 x	7.50-20-8 pr	7.50-20-8 pr Dual
Minimum for Max GVW	12.62	10.34	36.00	8.25-20-10 pr	8.25-20-12 pr Dual

VEHICLE WEIGHTS AND LOAD DISTRIBUTION

MODEL	WITH STANDARD EQUIPMENT						WITH MINIMUM EQUIPMENT FOR MAXIMUM GVW			
	Shipping			Curb			Body and Payload	Payload Distribution		Body Length
	Front	Rear	Total	Front	Rear	Total		Front	Rear	
6503(S)•	2720	2150	4870	2825	2255	5080	12625	9%	91%	168
								6%	94%	180
								2%	98%	192

3-25-55. Revised: 8-1-55. •-Production weights replace estimated weights x-Data Revised.  
96 - MODEL 6503 (6503S) DATA

CHEVROLET 1955 SPECIFICATIONS - TRUCK

CHASSIS AND BODY DIMENSIONS

MODEL 6702 SCHOOL BUS FLAT FACE COWL CHASSIS

MINIMUM GVW 14,000 LBS.  
MAXIMUM GVW 18,000 LBS.

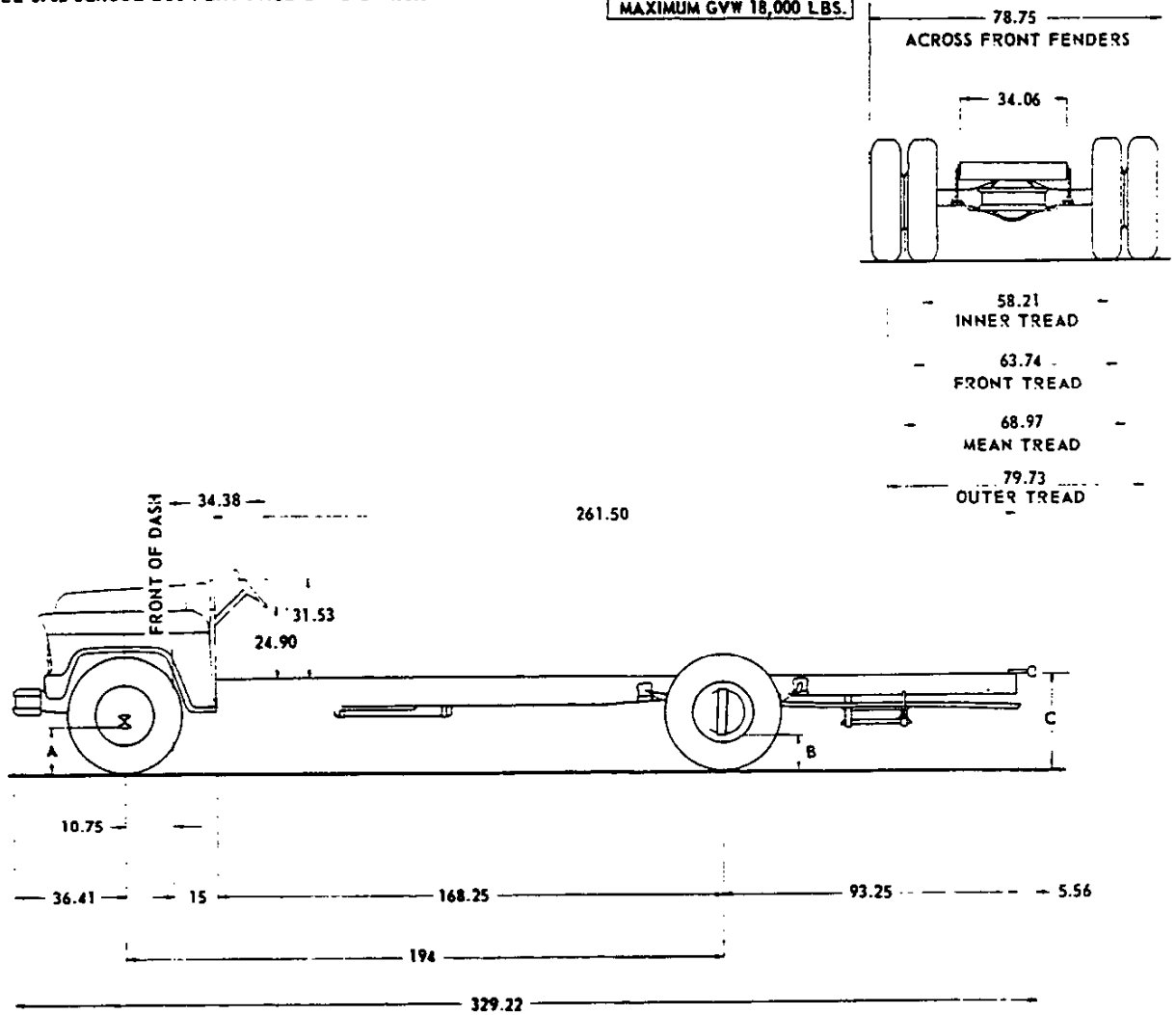

Equipment	Height Without Body and Payload			Tires	
	A	B	C	Front	Rear
Standard	12.02	9.74	36.01	7.50-20-8 pr	7.50-20-8 pr Dual
Minimum for Max GVW	12.62	10.34	38.00	8.25-20-10 pr	8.25-20-12 pr Dual

VEHICLE WEIGHTS AND LOAD DISTRIBUTION

MODEL	WITH STANDARD EQUIPMENT						WITH MINIMUM EQUIPMENT FOR MAXIMUM GVW			
	Shipping			Curb			Body and Payload	Payload Distribution		Body Length
	Front	Rear	Total	Front	Rear	Total		Front	Rear	
6702 ●	2405	2205	4610	2550	2345	4895	12800	Determined by style, length and weight of body		

3-25-55. Revised: 8-1-55. ●-Production weights replace estimated weights

CHEVROLET 1955 SPECIFICATIONS - TRUCK

MODEL 6702 DATA-97



### CHASSIS AND BODY DIMENSIONS

MODEL 6802 SCHOOL BUS FLAT FACE COWL CHASSIS

MINIMUM GVW 14,000 LBS.  
MAXIMUM GVW 18,000 LBS.

78.75  
ACROSS  
FRONT FENDERS

34.06

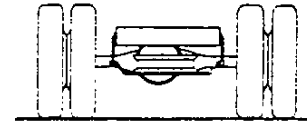

58.21  
INNER TREAD  
63.74  
FRONT TREAD  
68.97  
MEAN TREAD  
79.73  
OUTER TREAD

289

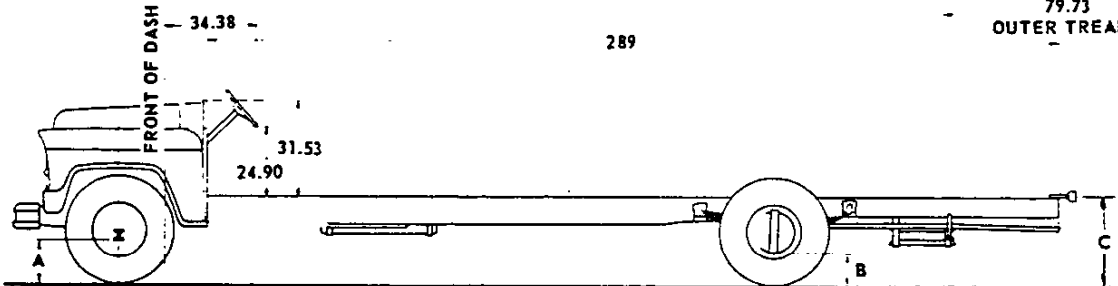

10.75

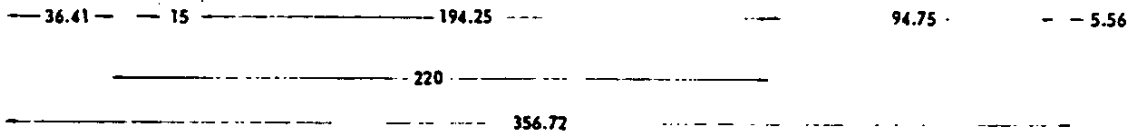

356.72

Equipment	Height Without Body and Payload			Tires	
	A	B	C	Front	Rear
Standard	12.02	9.74	35.75 x	7.50-20-8 pr	7.50-20-8 pr Dual
Minimum for Max GVW	12.62	10.34	37.77	8.25-20-10 pr	8.25-20-12 pr Dual

### VEHICLE WEIGHTS AND LOAD DISTRIBUTION

MODEL	WITH STANDARD EQUIPMENT						WITH MINIMUM EQUIPMENT FOR MAXIMUM GVW			
	Shipping			Curb			Body and Payload	Payload Distribution		Body Length
	Front	Rear	Total	Front	Rear	Total		Front	Rear	
6802 ●	2465	2220	4685	2625	2345	4970	12725	Determined by style, length and weight of body		

3-25-55. Revised: 8-1-55, ●-Production weights replace estimated weights x-Data Revised.

98 - MODEL 6802 DATA

CHEVROLET 1955 SPECIFICATIONS - TRUCK

CHASSIS TREADS AND OVERALL WIDTHS

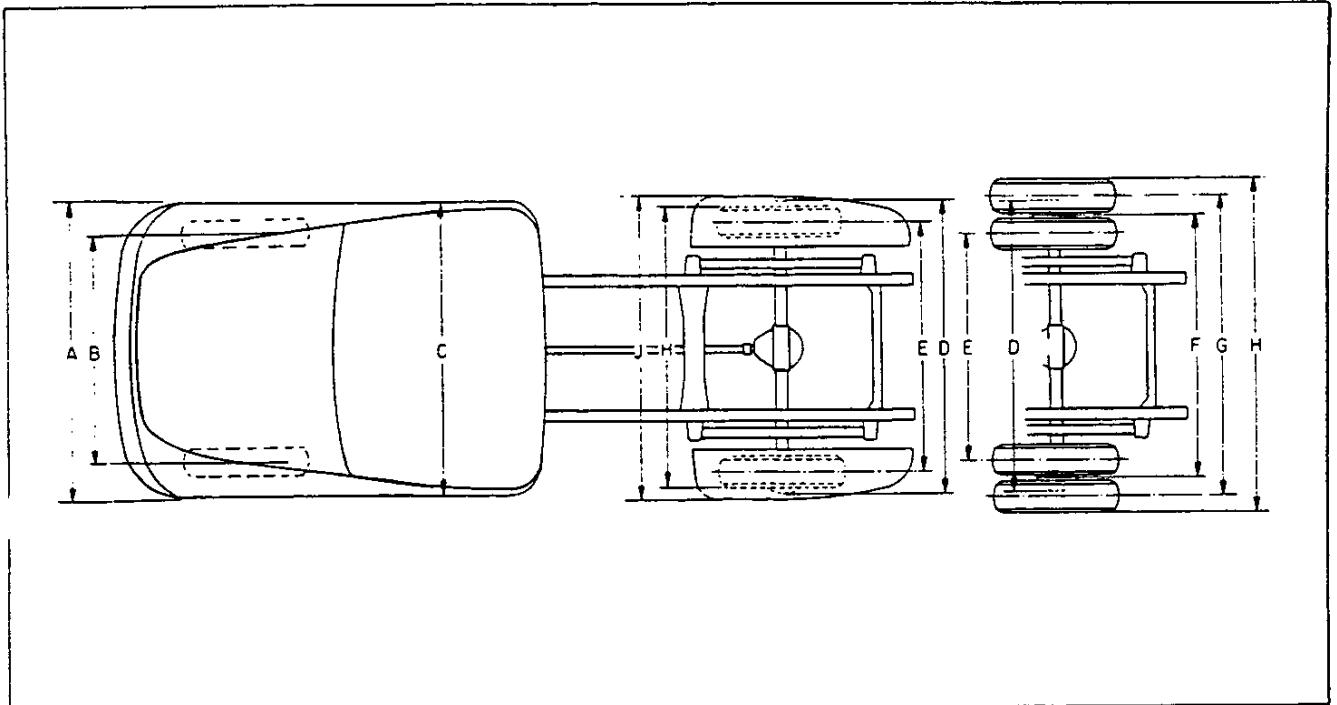

Tires	Models	A Across Front Fenders	B Front Wheel Tread	C Across Cab Widest Point	D Over Rear Hubs or Hub Caps	E Inner Wheel Tread	F Dual Mean Tread	G Outer Wheel Tread	H Over Rear Tires	J Over Rear Fender	
6.70-15	3100	74.52	60.54	75.03	70.30	61.02			67.94	%	
6.50-16	3200	on 3102	60.72			61.27			68.23		
15-6pr		74.68 all others	61.62			71.32	62.14				69.87
7.00-17	3400		63.26		72.38	61.75			69.33		
7.50-17	3500		63.24						69.76		
7.00-18	3700		63.64		71.25	54.13	63.25	72.37	79.95		
15-6 or 8pr	3600	74.52 on 3602 and 3802	61.64	75.03	72.38	62.40			70.13	76.00 on 3604 and 3804	
7.00-17			60.90								69.35
7.50-17			60.98								69.78
6.50-16			61.45				71.25	54.12	63.24		72.36
7.00-17	3800	74.65 all others	60.90		72.38	61.79			69.37	76.64 on 3805	
7.50-17			60.86						69.80		
7.00-18			61.30		71.25	54.13	63.25	72.37	79.95		
6.50-20	41-4000		63.65		77.04	56.98	66.48	75.98	83.24		
7.00-20	5.0 Wheels								83.90		
	41-4400*		61.70				55.85	66.61	77.37		84.70
7.50-20	6.0 Wheels										85.56
6.50-20	4500 (41-4400 RPO)		64.25				56.98	66.48	75.98		83.24
7.00-20	5.0 Wheels										83.90
	4500* (41-4400 RPO)	75.75	63.65			55.85	66.61	77.37	84.70		
7.50-20	6.0 Wheels								85.56		
7.50-20	5000		63.74	82.64 on 5000*		58.21		79.73	88.15		
8.25-20	6000								88.73		
8.25-20	5000										
Front 9.00-26 Rear	6000 with 20 x 6.5 Wheels		63.18	75.03 on 6000	80.85	57.73	68.97	80.21	90.16		

\* - Over fender step

% - 76.00 on 3104; 76.40 on 3105 and 3116; 77.00 on 3124

3-25-55. Revised: 8-1-55, e-Data Added x-Data Corrected  
CHEVROLET 1955 SPECIFICATIONS - TRUCK

### COWL DIMENSIONS

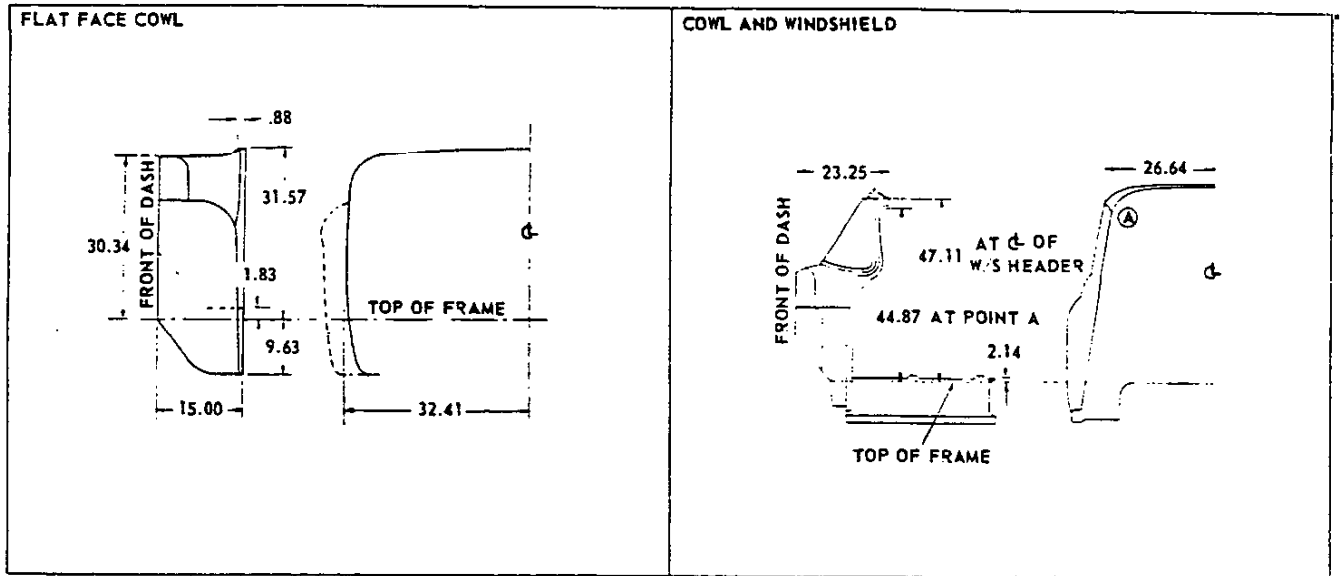

### CAB EXTERIOR DIMENSIONS

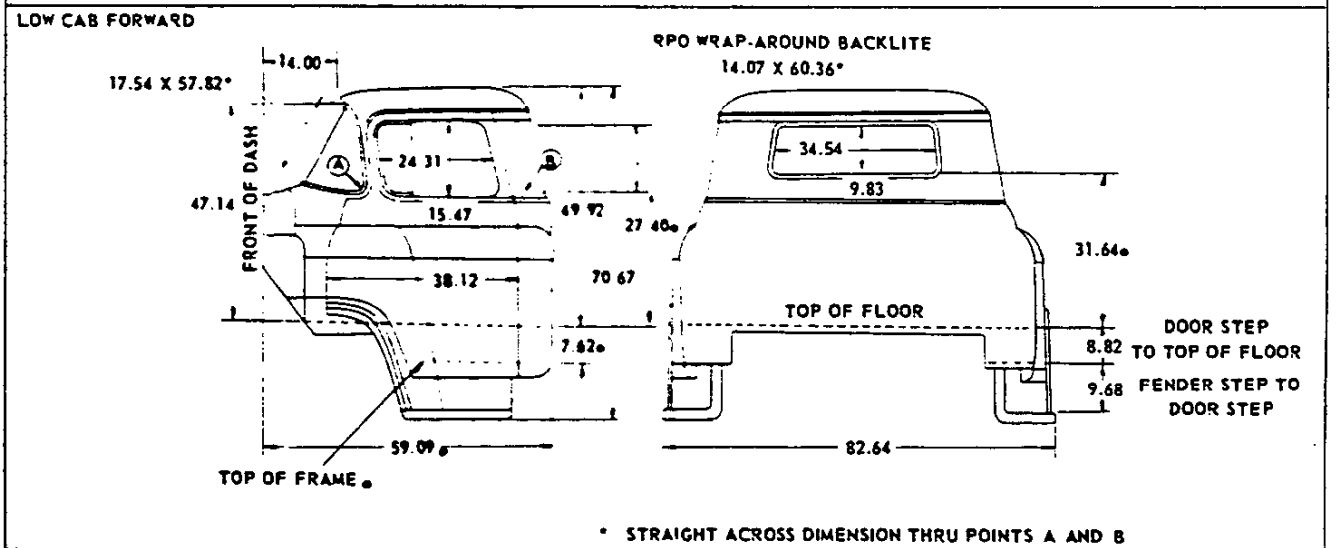
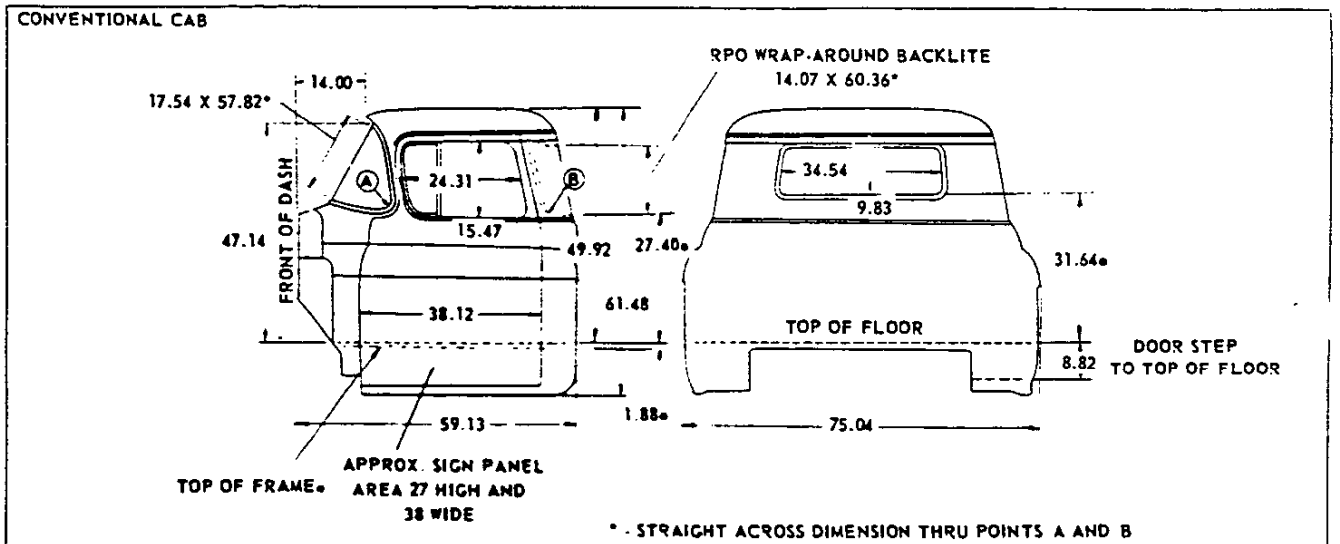

DRIVER COMPARTMENT AND SEAT DIMENSIONS

CONVENTIONAL AND LOW CAB FORWARD

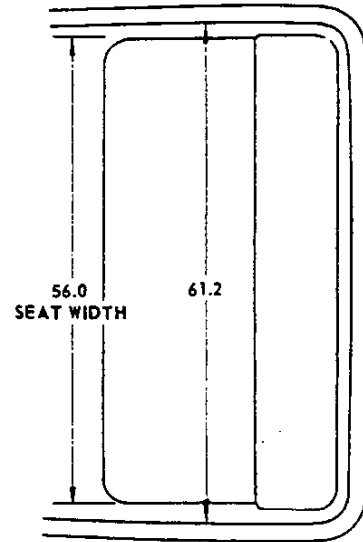
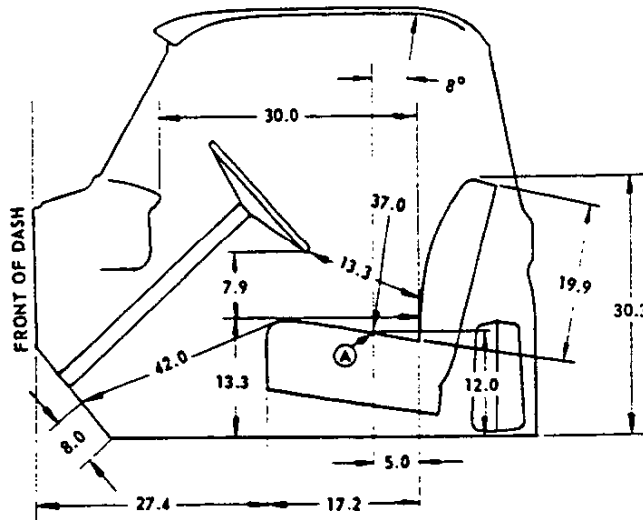

SEAT IN REAR POSITION  
SEAT ADJUSTMENT: 3.75

HIP ROOM  
(THRU "A" POINT)

PANEL AND SUBURBAN CARRYALL

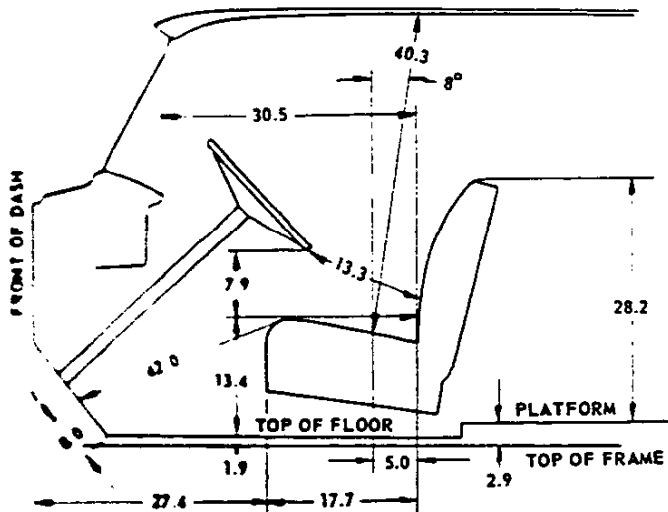
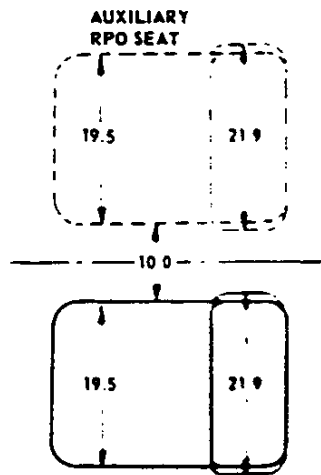

SEAT IN REAR POSITION  
SEAT ADJUSTMENT: 3.54

EXTERIOR APPEARANCE AND COLORS

Paint Colors: Solid

ITEM	BODY	WHEELS	WHEEL STRIPES
Standard-All models*	Juniper Green	Black on all models	
RPO 234	Commercial Red		
All Models Except 3124	Sand Beige		
	Jet Black		
	Omaha Orange		
	Granite Gray		
	Empire Blue		
	Cream Medium		
	Yukon Yellow		
	Ocean Green		
	Crystal Blue		
	Russet Brown		
	Pure White		

\* - Except Model 3124

Paint Colors: Two-Tone #

ITEM	BODY		WHEELS	WHEEL STRIPES	
	UPPER	LOWER			
RPO's 443 & 444 on all cab models * RPO 445 on Model 3105; RPO 446 on Model 3805	Bombay Ivory	Juniper Green	Lower body color on 3000 Series; All others, Black	@ Bombay Ivory	
	Bombay Ivory	Commercial Red		@ Argent Silver	
	Bombay Ivory	Jet Black		@ Bombay Ivory	
	Bombay Ivory	Empire Blue		@ Bombay Ivory	
	Bombay Ivory	Cream Medium		@ Bombay Ivory	
	Bombay Ivory	Yukon Yellow		@ Bombay Ivory	
	Bombay Ivory	Ocean Green		@ Bombay Ivory	
	Bombay Ivory	Crystal Blue		@ Bombay Ivory	
	Bombay Ivory	Granite Gray		@ Bombay Ivory	
	Bombay Ivory	Omaha Orange		@ Bombay Ivory	
	Bombay Ivory	Sand Beige		@ Bombay Ivory	
		Sand Beige		Russet Brown	@ Bombay Ivory
	Standard - 3124	Commercial Red		Bombay Ivory	† Commercial Red

@ - On 15-5K and 16 x 5K Wheels only. † - On 16 x 5K Wheels only. \* - Except Model 3124

# - Deluxe equipment and two-tone options are not available for models 3106-16

HOOD AND GRILLE APPEARANCE

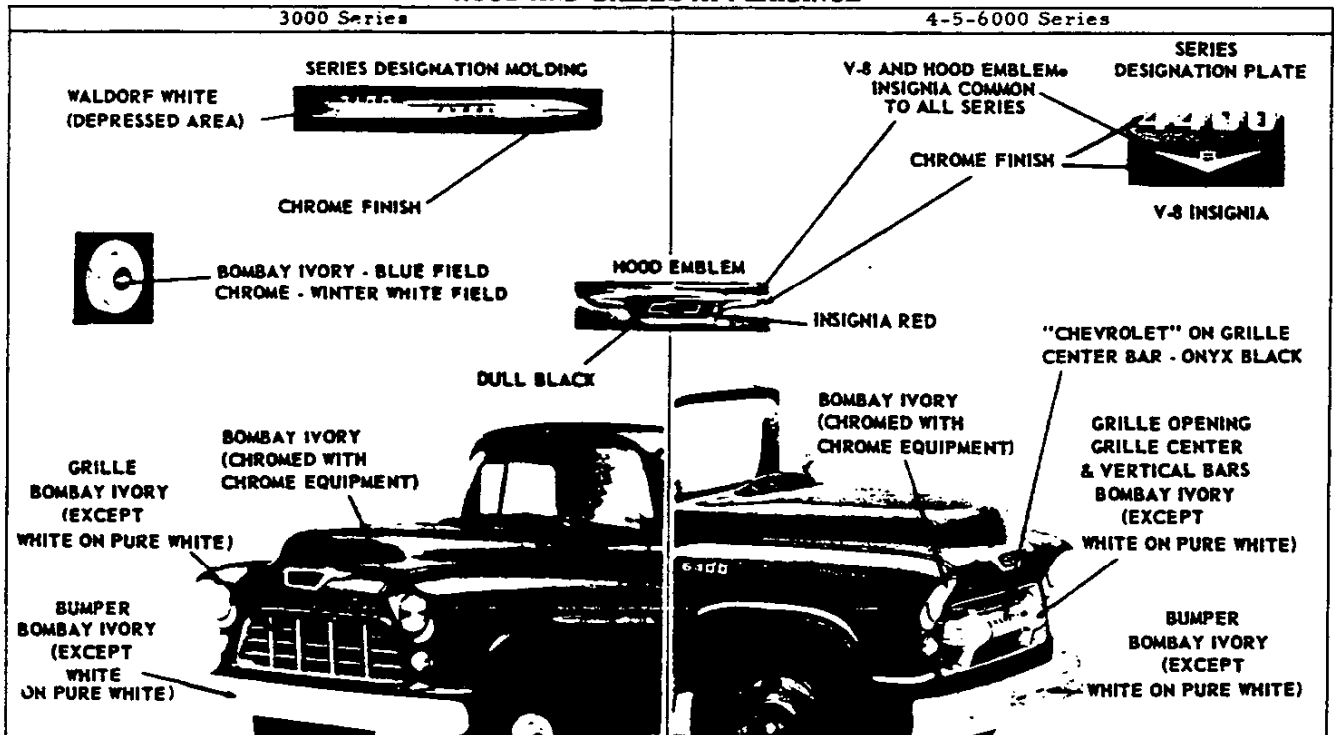

3-25-55. Revised: 8-1-55, --Data added.  
102 - EXTERIOR APPEARANCE AND COLORS

CHEVROLET 1955 SPECIFICATIONS - TRUCK

FRAME

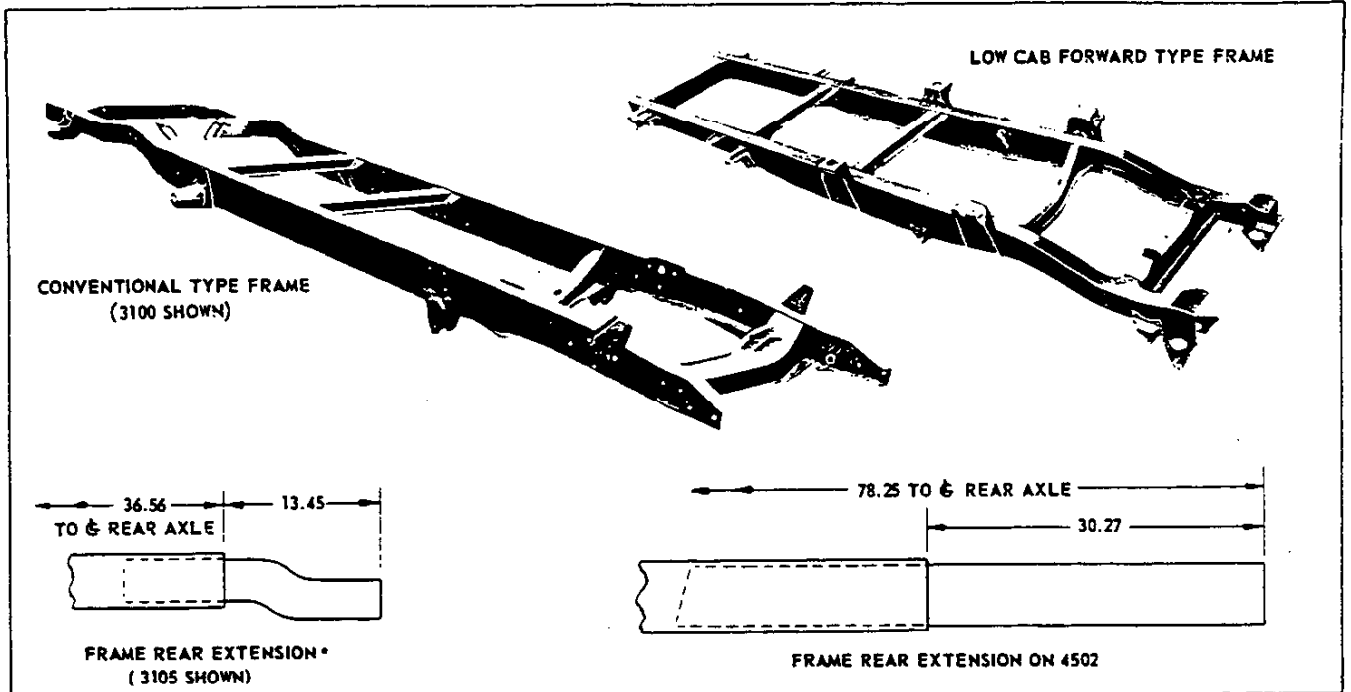

MODEL	Wheel base	Frame Overall Length	Width Over Side Members	Number Of Cross Members +	Section Modulus ‡	
CONVENTIONAL	3100	114.00	34	5	2.54	
	3200	123.25			3.37	
	3400	104.00		4	5.70	
	3500	125.00				191.01
	3600	123.25		5	3.37	
	3700	137.00			202.99	
	3800	135.00		208.18	5.70	
	4100	130.00		222.50*	8.28	
	4400	154.00		236.46	9.41	6
	6100	130.00		199.40		5
6400	154.00	236.46	6			
6500	172.00	266.48	7			
8						
SCHOOL BUSES	4500	154.00	34.06	9	10.36	
	6700	194.00				321.73
	6800	220.00				349.23
L. C. F.	5100	112.62	34	6	9.41	
	5400	136.62				219.33
	5700	160.62				255.33

FRAME TYPE --- Ladder; with straight thru channel side members

SIDE MEMBER DATA:

Section type ----- Channel

Kick-up height, at rear axle:

1.68 on 3100

1.53 on 3200, 3600

2.27 on 3400, 3500, 3700

Material ----- Hot rolled steel, pickled

Yield point ----- 39000 PSI (Min.)

Elongation ----- 25% in two inches

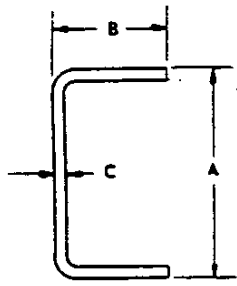

SERIES	Max Sectional Dimensions		
	A	B	C
3100	6.00	2.26	.14
3400, 3500	7.25	2.75	.22
3700, 3800			
3200, 3600	6.09	2.25	.19
4100	9.06	2.97	.22
4400, 4500, 5000	9.12	3.00	.25
6100, 6400, 6500			
6700, 6800			
	9.18	3.03	.28

\* - Length includes regular production rear extensions on models 3105, 3106, 3116, 3805 and 4502 and RPO rear extensions on models 3102, 3103, 3112, 3602, 3603 and 3612.

‡ - Inches cubed per side member.

+ - Structural cross members; those which are so attached as to resist torsional frame stresses.

3-25-55

CHEVROLET 1955 SPECIFICATIONS - TRUCK

FRONT AXLE

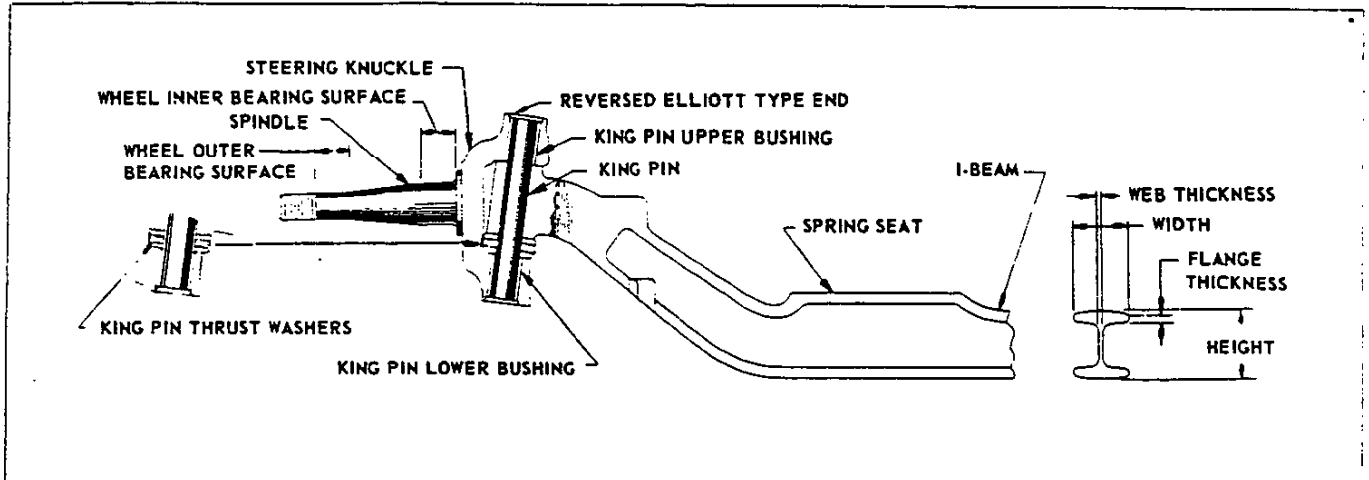

ITEM	3100-3200	3600	3800	4100 4400	3400 3500 3700	45-5000-61-64-6000 (RPO 41-4000)	6702 6802	
Type	Reverse Elliott (modified I-beam section)							
Rated capacity (pounds)	2200	2500	3500	4000	4500	4750		
I-beam (average dimen- sions)	Height	2.06-2.12	2.19-2.34		2.44-2.59			
	Width	1.68-1.76	1.94-2.06					
	Flange thickness	.20	.32		.44			
	Web thickness	.24	.25		.22-.28			
	Section Modulus @	.72	1.05		1.37			
King pin	Diameter	.8660-.8665	.9210-.9214		1.1090-1.1094			
	Bushing Type	Floating		Pressed into steering knuckle				
	Length x I.D.	1.313 x .867-.868	1.516 x .922-.923		1.375 x 1.110-1.111			
King pin thrust bearing	Type	Copper and steel washers						
	Diameter	Inside	.872-.882		.927-.937		1.130 across flats after coining	
		Outside	1.547-1.557					2.031
Spindle diameter	At inner bearing	1.2301-1.2806	1.4986-1.4991		1.7491-1.7496			
	At outer bearing	.7490-.7495	.9052-.9057		1.0291-1.0296			
Steering knuckle stop	Adjustable, Nut and bolt type							
Front Wheel bearing	Anti-friction bearings-See pages 148-151							

FRONT WHEEL ALIGNMENT

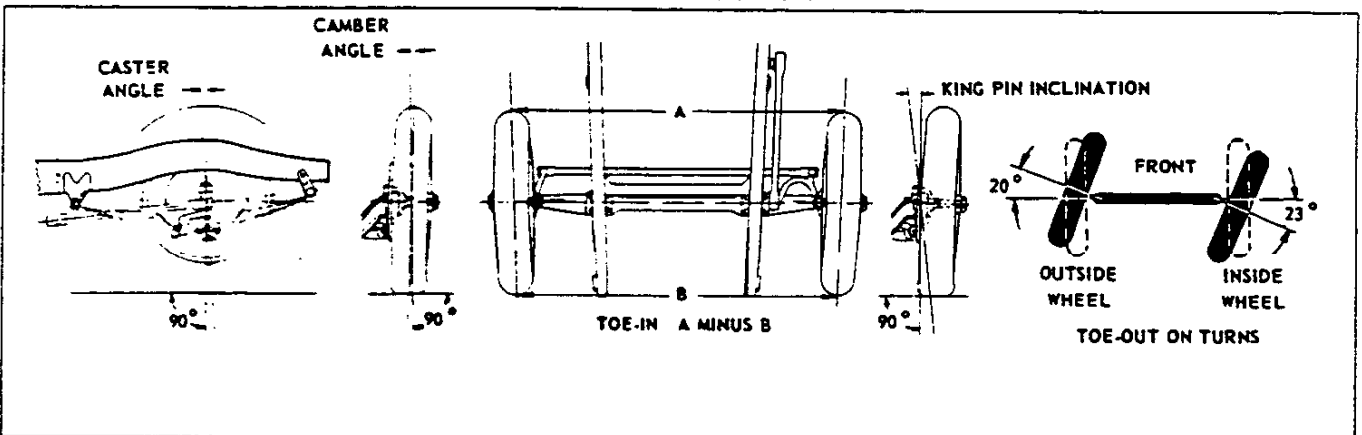

ITEM	3100-3200	3600-3800	34-35-3700	4100-4400	4500	5000	6000
King pin inclination	6.16° to 8.16°						
Camber	0° 30' - 1° 30'						
Caster at design load	3.0°	2.75°	3.25°	2.5°	2.75°	2.75°	3.0°
Caster at curb weight	§	§	§	§	§	§	§
Toe-in	.132 to .219		.25 to .31				
Toe-out on turns	Outside Wheel	20°					
	Inside Wheel	22.5°-23.5°					

\* Without shims. § Information not available. @ -Inches cubed.

**FRONT SUSPENSION**

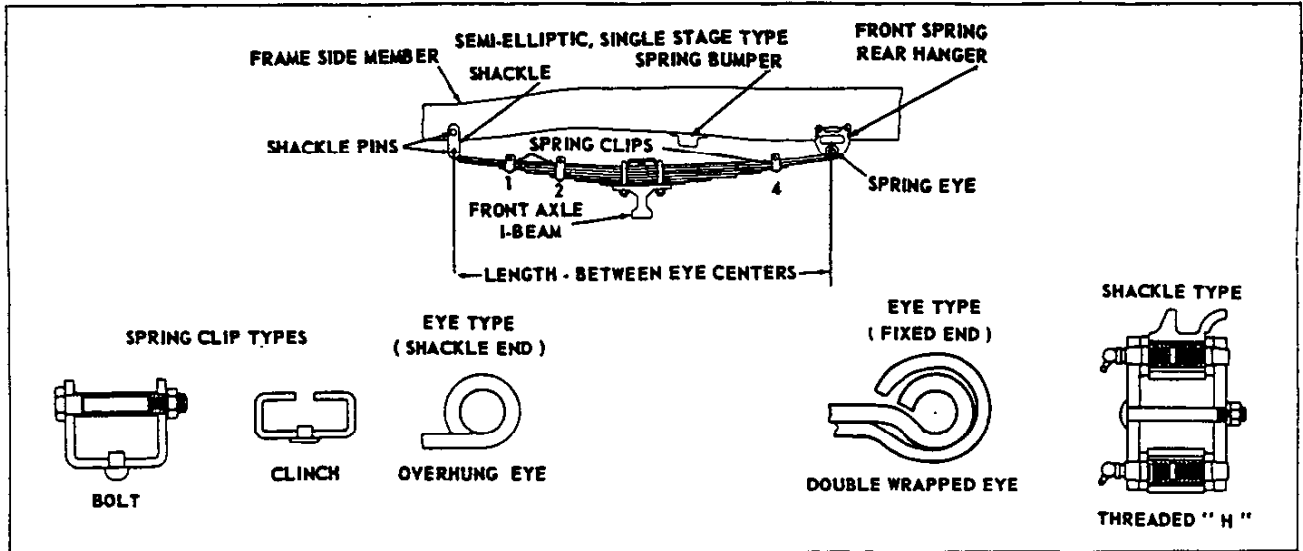

ITEM	3100		3800	3400		4000		5000	RPO 5000	6700		
	3200	3600		3500	3700	6100	6400			6500	(RPO 3400 3500-3700 6100-6400 6500)	
Springs	Type	Semi-elliptic										
	Material	Chrome carbon steel										
	Number	6		7	8			9	10			
	LEAVES (Thickness Leaves Numbered from top to bottom)	Leaf #	1-2		.323		.323			.323		
		3										
		4										
		5					.291			.360		
		6										
		7										
		8										
		9										
		10										
		Total	1.746	2.101	2.328	2.456	2.88	3.24	3.07			
	Load in pounds at opening height	826-906 @ 1.70	900-1000 @ 1.74	1082-1196 @ 1.37	1020-1170 @ 1.93	1662-1938 @ .94	1946-2234 @ .82	1563-1713 @ 1.52				
	Average rate of deflection (lbs per inch)	304	410	424	500	547	616	628				
Rated Capacity (lbs)	At pad x 1000	1100	1700	1750	2100	2300	2200					
Capacity (lbs)	At ground 1170	1300	2000	2050	2450	2600	2500					
Length x Width	44 x 2											
Spring clip type (See Fig)	Clinch 1-2-4	Bolt 1-4		1-2-4			1-2-4		1-2-4			
Spring mounting	Shackle end	Located at Front		Rear		Front		Rear		Front *x		
	Type	Threaded "H"-11 thread										
	Pin diameter and length	.6595-.6645 x 3.3125		.6595-.6645 x 3.56			.6595-.6645 x 3.3125					
	Fixed end	Plain .8745 OD										
	Bushing	.6035 OD x 3.625		.6825 OD x 4.0			.6035 x 3.625					
	Bolt size	.50, 31-3200; All others .562		.625			.56					
	U-bolt diameter	.56										
	Bumper	Rubber, on frame side member lower flange										
	Spring center-to-center	31.88 (Measured on axle I-beam)		32.81 (Measured on axle I-beam)								
	Ride stabilizer	3102-3105-3106-3112-3116-3442-3542-3742, Frame to front springs										

**FRONT SHOCK ABSORBERS**

ITEM	31-32-34-35-36-37-38 Reg	4000, 61-64-6500 RPO	5000 Regular	67-6800 RPO
Model & Valve Code	820R, 180/A1.5-82	682Z, 03J10/C2	660AA,04N10/D3	682Z, 03D6/A3
Piston diameter	1.00	1.375	1.375	1.375

\* - At rear for series 3400-3500-3700 x  
 3-25-55. Revised: 8-1-55. e-Data Corrected, x-Data added, o-Data revised.  
**CHEVROLET 1955 SPECIFICATIONS - TRUCK**



REAR AXLE

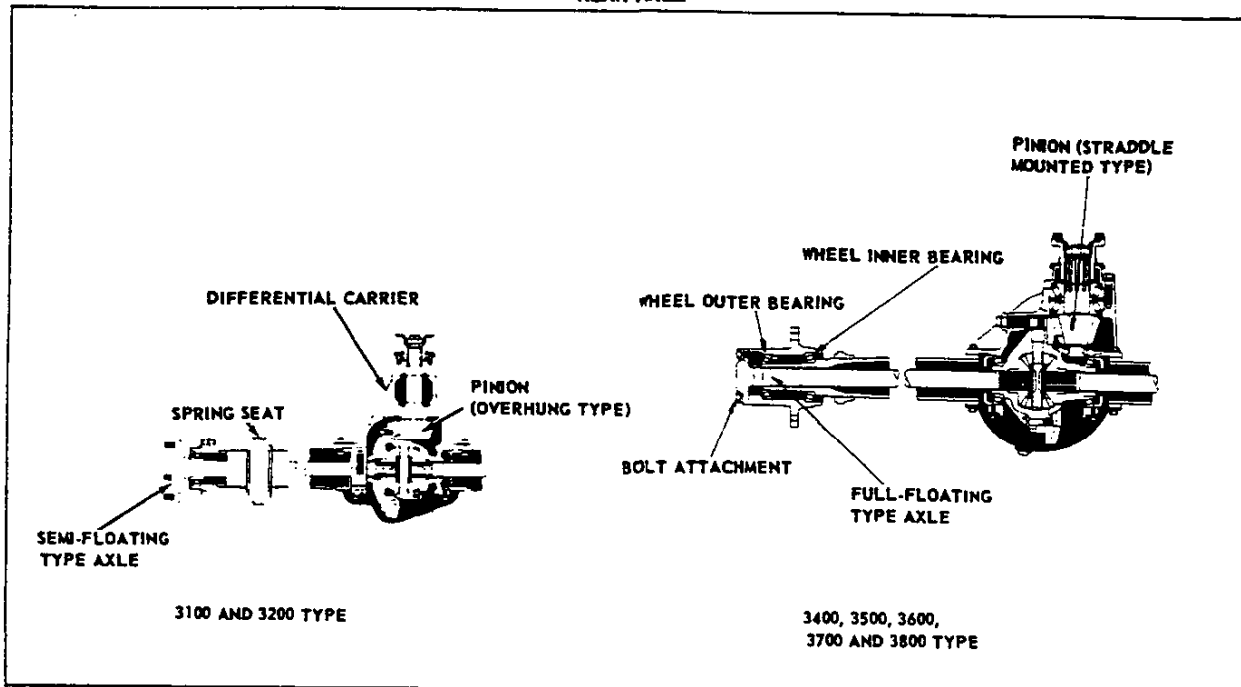

ITEM	3100 3200	RPO 3100 3200	3400 3500 3700	RPO 3400 3500 3700	3600	3800
Type	Semi-floating		Full-floating			
Rating (pounds)	3300		5000	7200	5000	7200
Housing	Banjo					
	Two piece welded		One or two pc welded		Two piece welded	One pc welded
	HR Steel		HR Steel or seamless tube		Seamless tubing	HR Steel
Final gears	Spiral Hypoid					
	Type					
	Ratio	3.90:1	4.11:1	5.14:1	4.57:1	5.14:1
	Teeth	39 & 10	37 & 9	36 & 7	32 & 7	36 & 7
Gear backlash	.005 - .008					
Pinion	Overhung		Straddle			
	Mounting					
	Adjustment	Shims				
	Thrust	Against pinion rear brg		Against pinion front bearing		
* Max gear reduction in low gear	3-Speed Trans.	11.47		15.11	13.44	
	3-Speed HD	12.36		16.29	14.49	16.29
	Automatic	14.90		24.21	21.53	24.21
	4-Speed	27.53		36.29	32.27	36.29
	Overdrive		12.08			
e Maximum axle shaft torque in low gear Ⓞ	3-Spd. 6 Cyl.	1901		2415	2228	
	Conv. 8 Cyl.	2145			2513	
	3-Spd. 6 Cyl.	2049		2603	2402	2700
	H. D. 8 Cyl.	2311			2710	3046
	Auto-matic 6 Cyl.	2470		3869	3569	4013
	8 Cyl.	2656 Ⓞ			4026	4527
	4-Spd. 6 Cyl.	2656 Ⓞ		5799	5349	6015
	8 Cyl.	2656 Ⓞ			6034	6786
	Over drive 6 Cyl.		2002			
	8 Cyl.		2259			
Lubricant capacity	4-1/2 pints			6-1/2 pints		
Differential type	Two pinion			Four pinion		
Axle shaft	Shaft and drive flange integrally formed					
	Type					
	Minimum dia	1.156		1.344		
	Hub attachment	Integral			Bolted	
Drive taken through	Springs (Hotchkiss)					
Torque taken through						
Anti-friction bearings	See pages 150-153					

\* - Axle ratio x transmission ratio.  
 Ⓞ - Gear reduction x engine maximum net torque x efficiency factor (.90 in direct drive, .85 all others).  
 Ⓢ - Maximum capacity of shafts.

CONTINUED

REAR AXLE - Continued

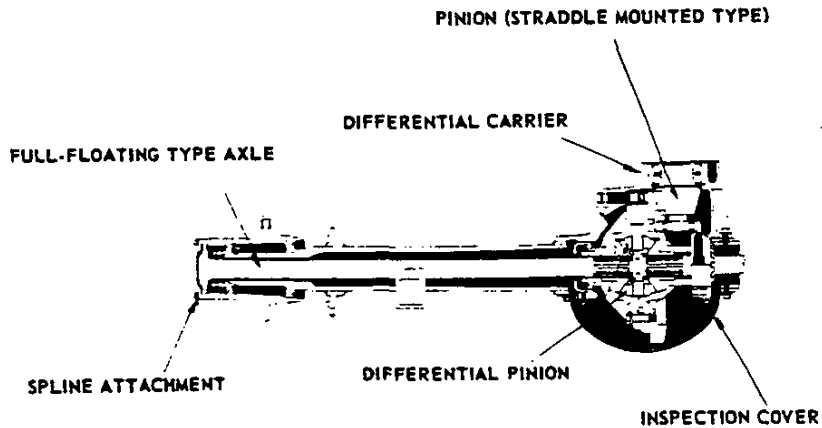

4000, 5000, AND 6000 TYPE

ITEM		4000	5000	5000 RPO	6000	6000 RPO
Type		Full-floating				
Rating (pounds)		11000	15000		13000	15000
Housing	Type	Banjo				
	Construction	One pc welded	One piece		One or two pc welded	One piece
Material		HR Steel				
Material		Seamless Steel Tubing				
Final gears	Type	Spiral Hypoid				
	Ratio	6.17:1	6.17:1	7.20:1	6.17:1	6.17:1   7.20:1
	Teeth	37 & 6		36 & 5	37 & 6   36 & 5	
Gear backlash		.005 - .008				
Pinion	Mounting	Straddle				
	Adjustment	None	Shims		None	Shims
	Thrust	Against pinion front bearing				
*Max gear reduction in low gear	4-Speed Transmission	43.56		50.83	43.56   50.83	
Ø Max axle shaft torque in low gear	6 Cyl., 235 Eng.	7220			7220   8425	
	6 Cyl., 261 Eng.				7961   9290	
	8 Cyl., 265 Eng.	8146		9506	8146   9506	
Lubricant capacity		14 pints		16-1/2 pints		
Differential type		Four Pinion				
Axle shaft	Type	Shaft and drive flange integrally formed				
	Minimum dia	1.438		1.68		
	Hub attachment	Splined				
Drive taken through		Springs (Hotchkiss)				
Torque taken through		See pages 150-153				
Anti-friction bearings		See pages 150-153				

\* - Axle ratio x transmission ratio.

Ø - Gear reduction x engine maximum net torque x efficiency factor (.90 in direct drive, .85 all others).

REAR SUSPENSION

SEMI-ELLIPTIC, SINGLE STAGE



SEMI-ELLIPTIC, TWO-STAGE



SPRING CLIP TYPES

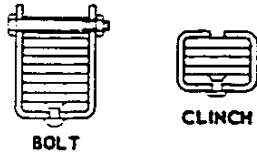

SPRING SHACKLE TYPES

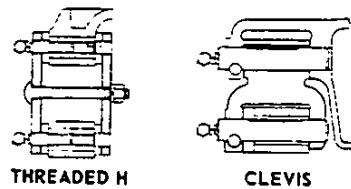

ITEM	3100-3200		3600			
	Regular	RPO	Regular	RPO	RPO	
Springs	Type	Two-stage	Sgle-stage	Semi-elliptic		
	Material	Chrome carbon steel				
	Number	7	8	9	10	
	LEAVES Numbered From Top To Bottom)	M A I N A U X	1, 2	.291	.323	
			3, 4, 5			
			6	.291		
			7	.323		
			8			
			9			
			10			
	Total	2,069	2,328	2,843	3,134	3,198
	Load in pounds at opening height	1100-1235 @ .44	1375-1475 @ .44	1334-1434 @ .44	1524-1624 @ .44	2006-2106 @ .44
	Average rate of deflection (Pounds per inch)	1st Stage	248	1st Stage	1st Stage	
		2nd Stage		2nd Stage	2nd Stage	
		175 @ 140-425 237 @ 800-1350		250 @ 200-600 370 @ 900-1500	285 @ 200-600 405 @ 1025-1700	430
Length x Width	52 x 2					
Spring Clip Type (See Fig)	Clinch	1 & 4		1 & 4		
	Bolt	3		3		
Rated Capacity (lbs)	On pad x	11	135	1450	1650	2100
	At ground	125	155	1700	1925	2400
Spring mountings	Shackle End	Located at:	Rear			
		Type	Threaded H			
		Pin dia	.6595-.6645, 11 Thread			
	Fixed End	Bushing	.687-.690 ID			
		Bolt or Pin	.685-.689			
	Attachment to axle	Two U-Bolts, Spacer and plate				
	U-Bolt diameter	.45		.625		
Bumper	Rubber, mounted on frame side member lower flange					
Center to Center	41.52					

REAR SHOCK ASSORBERS

ITEM	3100 Standard	32-3600 Standard
Type	Direct double acting	
Model & valve code	800 W181 A2 5e	800 Z 181/A 2.5
Piston diameter	1.00	

3-25-55. Revised: 8-1-55. e-Data Corrected. x Data Added  
108 - REAR SUSPENSION

REAR SUSPENSION - Continued

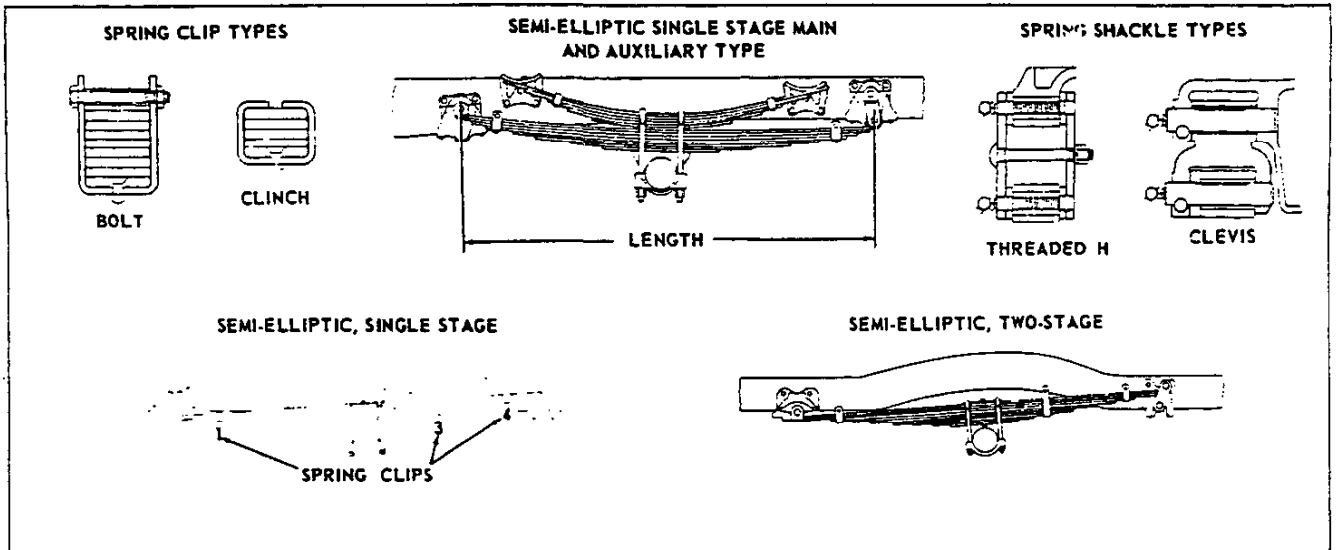

ITEM		3800	34-35-3700 3800 RPO	34-35-3700 3800 †	
		Regular	Regular	RPO	
Springs	Type	Semi-elliptic Two-stage	Semi-elliptic Single-stage	Semi-elliptic Single- Stage Main & Auxiliary	
	Material		Chrome carbon steel		
	Number		8	8	8 Main; 5 Aux
	L E A V E S T O B O T T O M	Thickness	M 1, 2	.323	.323
			A 3, 4, 5	.291	
		Numbered	I 6	.360	
			N 7		
			X 8		
		From	N 9		
			N 10		
	Total		2.530	2.552	2.552
	Bottom)		A 1, 2, 3		.291
			U 4, 5		
			X Total		1.455
	Load in pounds at opening height		1575-1725 @ 1.60	1893-2093 @ 1.62	1893-2093 @ 1.62 (Main 2322-2838 @ 2.62 (Main and auxiliary.)•
Average rate of deflection (Pounds per inch)		1st Stage 315 @ 250-750 2nd Stage 435 @ 1400-1800	424	424 Main 625 Auxiliary	
Length x Width		52 x 2.5			
Spring Clip Type (See Fig.)	Clinch			1 & 4 Auxiliary	
	Bolt	1, 3, & 4	1 & 4	1 & 4 Main	
Rated Capacity (lbs)	On pad x	2000	2050	3000	
	At ground	2300	2400	3450	
Spring mountings	Shackle		Rear		
	End	Located at	Clevis & plain bushing		
		Type			
			Pin dia		
			.874-.875 O. D.		
	Fixed End	Bushing		.976-.880 I. D.	
		Bolt or pin		.874-.875 O. D.	
	Attachment to axle		Two U-Bolts, Spacer and plate		
U-Bolt diameter		.625			
Bumper		Rubber, mounted on frame side member lower flange			
Center to Center		40.00			
<b>REAR SHOCK ASSORBERS</b>					
ITEM		34-35-3700 Standard; 3800 RPO			
Type		Direct double acting			
Model & Valve Code		684 U, 04N10/A1			
Piston diameter		1.375			

† - For Models 3802-03-08-09-12 Only.  
 3-25-55. Revised: 8-1-55. • - Data Revised, x - Data Added.  
 CHEVROLET 1955 SPECIFICATIONS - TRUCK

REAR SUSPENSION - Continued

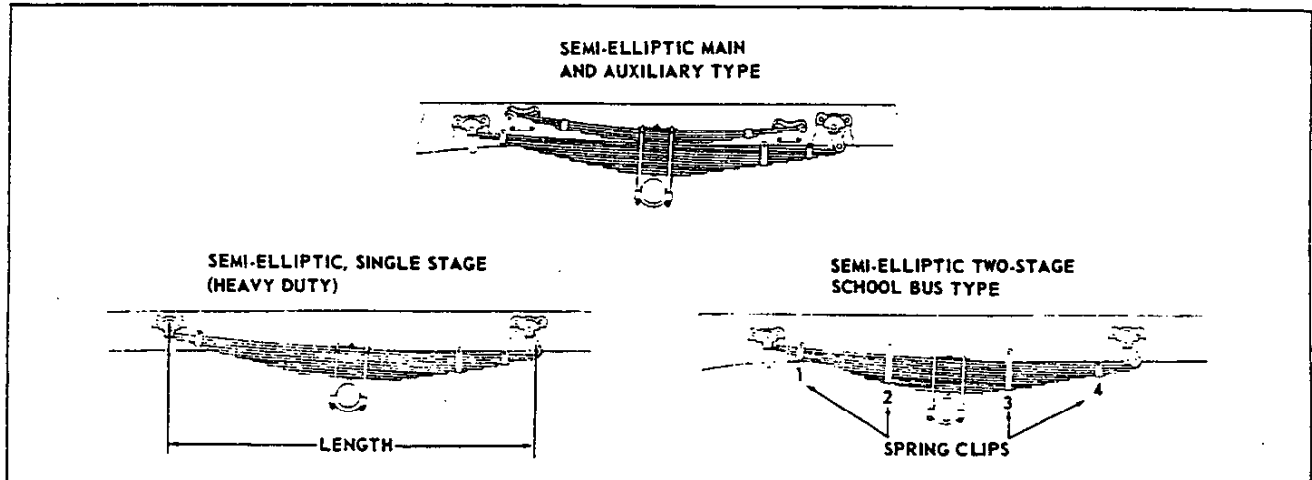

ITEM		4100-4400 Regular	4100-4400 RPO	4500 Regular	
Springs	Type	Semi-elliptic Single-stage	Semi-elliptic Single- Stage Main & Auxiliary	Semi-elliptic Two-stage	
	Material	Chrome carbon steel			
	Number	10	10 & 5	12	
	L E A V E S  (From Top To Bottom)	Thickness (Leaves Numbered From Top To Bottom)	1, 2, 3, 4	.401	.360
			5, 6, 7, 8		
			9		
			10		
			11		
		M A I N	12	4.010	.401
			13		
			14, 15		
			Total		
			Total		
	A U X	1, 2, 3	.401	.360	
		4			
5					
6					
Total	1.923				
Load in pounds at opening height	3301-3649 @ 1.23	3534-3906 @ 1.00 (Main) 3942-4818 @ 1.54 (Main and auxiliary)*	3520-3890 @ .88		
Average rate of deflection (Pounds per inch)	1113	1118 (Main) 1465* (Auxiliary)	1st Stage 780 @ 500-1000 2nd Stage 1030 @ 3500-4500		
Length x Width	52 x 2.5				
Spring Clip	Clinch	1 & 4 (Auxiliary)			
Type (See Fig.)	Bolt	1, 3 & 4 (Main)	1, 2, 3 & 4		
Rated	On pad x	4400	5050	3750	
Capacity (lbs)	At ground	5000	5700	4350	
Spring Mountings	Shackle End	Located at	Rear		
		Type	Clevis & plain bushing		
	Fixed End	Bushing	.874-.875 O.D.		
		Bolt or Pin	.876-.880 I.D.		
	Attachment to axle	U-Bolt diameter	.874-.875 O.D.		
		U-Bolt diameter	.750		
	Bumper	Rubber, mounted on frame side member lower flange			
Center to Center	40.00				

REAR SHOCK ABSORBERS

ITEM	41-44-4500 RPO
Type	Direct double acting
Model & valve Code	660U, O4N10/A1
Piston diameter	1.375

3-25-55. Revised: 8-1-55, \*Data Revised x-Data added.

REAR SUSPENSION

SEMI-ELLIPTIC MAIN AND AUXILIARY TYPE

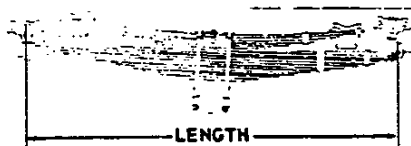

SEMI-ELLIPTIC, TWO-STAGE SCHOOL BUS TYPE



ITEM		5000-61-64-6500 Regular	5000-61-64-6500 RPO	67-6800 Regular	67-6800 RPO				
Springs	Type	Semi-elliptic, Single-stage Main and Auxiliary		Semi-elliptic, Two-stage					
	Material	Chrome carbon steel							
	Number	11 & 5	13 & 6	13	15				
	L E A V E S	Thickness (Leaves Numbered From Top To Bottom)	M	1, 2, 3, 4	.360	.401			
				5, 6, 7, 8					
			N	9					
				10					
				11					
				12					
	S	U X	13	.360	.401				
			14, 15						
			Total			4.411	5.213	4.844	5.605
			Total			1.423	2.324		
	Load in pounds at opening height	Main 4161-4599 @ .56 Main & Auxiliary 5130-6270 @ 1.10	Main 4522-4998 @ .85 Main & Auxiliary 5950-7270 @ 1.00	3800-4200 @ 1.00	4420 @ 1.00				
	Average rate of deflection (Pounds per inch)	1160 (Main) 1465 (Auxiliary)	1368 (Main) 1796 (Auxiliary)	1st Stage 860 @ 500-1000 2nd Stage 1106 @ 3500-4500	1st Stage 936 @ 600-1100 2nd Stage 1287 @ 3920-4920				
Length x Width	52 x 2.5								
Spring Clip Type (See Fig.)	Clinch	1 & 4 (Auxiliary)	1, 2, 3 & 4						
Rated Capacity (lbs)	On pad	5950	6600	4850	5500				
	At ground	6740	7600	5500	6300				
Spring Mountings	Shackle End	Located at:	Rear						
		Type	Clevis & plain bushing						
		Pin dia	.874-.875 O.D.						
	Fixed End	Bushing	.876-.880 I.D.						
		Bolt or Pin	.874-.875 O.D.						
	Attachment to axle	Two U-Bolts, Spacer & plate							
	U-Bolt diameter	.750							
Bumper	Rubber, mounted on frame side members lower flange								
Center to Center	40.00								

REAR SHOCK ABSORBERS

ITEM	5000, 67-6800 RPO
Type	Direct double acting
Model & Valve Code	660 U, 04N10/Al
Piston diameter	1.375

TWO - SPEED REAR AXLE (RPO 243 FOR 4000, RPO 201 AND 202 FOR ALL 5000 - 6000 MODELS)

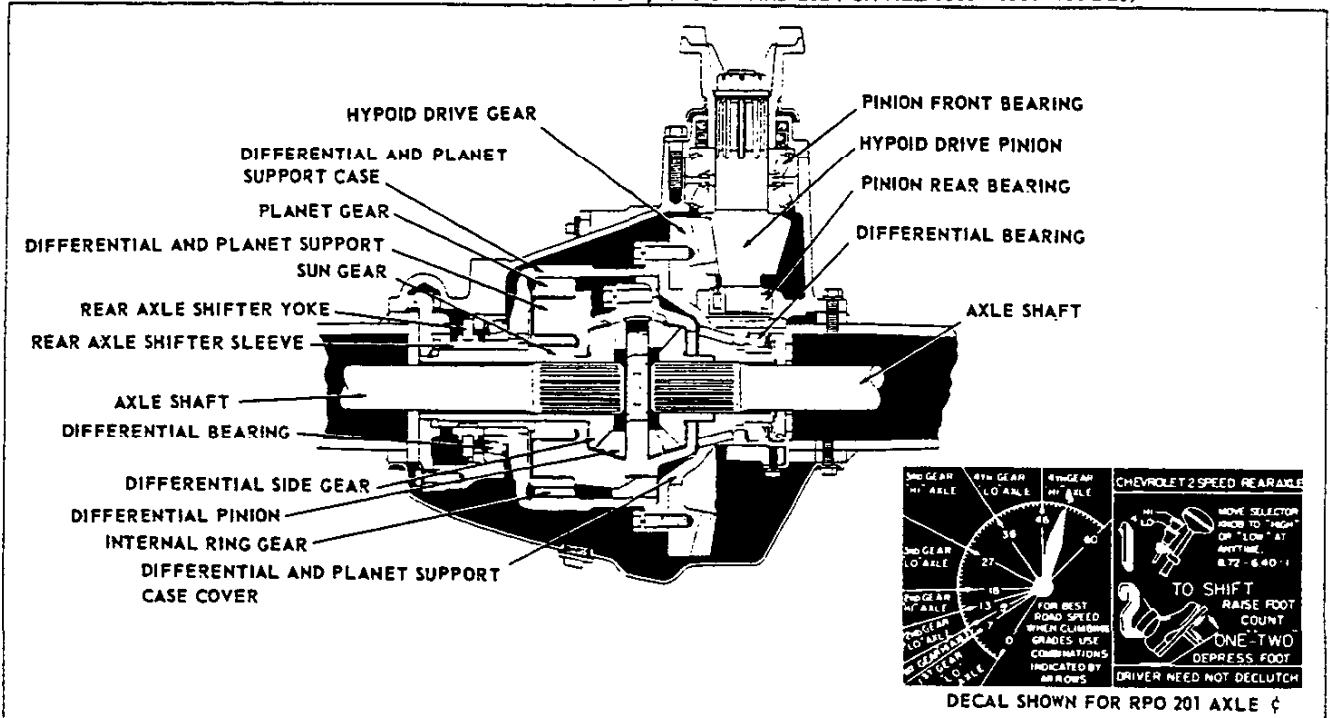

ITEM		RPO 4000-5000-6000	RPO 5000-6000	
Make and Type		Own-Full Floating - Two Speed - Planetary		
Rating (pounds)		15000		
Housing	Type	Banjo		
	Construction	One piece forged		
	Material	Seamless steel tube with HR steel reinforcements		
Axle Shaft	Type & Material	Shaft and drive flange integral - Upset forged steel		
	Minimum Diameter	1.68		
	Hub Attachment	Splined		
Differential type		Four pinion		
Pinion	Mounting	Straddle		
	Adjustment	Shims		
	Thrust	Against pinion front bearing		
Final Gears	High Speed	Gear Reduction	Hypoid pinion & driven gear	
		No. of Teeth	6 & 35	5 & 32
		Ratio	5.83:1	6.40:1
	Low Speed	Gear Reduction	Pinion and driven gear (primary) Planetary ring gear and sun gear (secondary)	
		No. of Teeth	6 & 35 (primary) 47 & 17 (secondary)	5 & 32 (primary) 47 & 17 (secondary)
Ratio		7.95:1	8.72:1	
Range Selector	Control and Type	Remote; Vacuum		
	Location	Knob on gearshift lever		
Maximum gear reduction in low transmission gear*	4-Speed	High Speed	41.16	45.18
		Low Speed	56.13	61.56
Maximum axle shaft torque in low transmission gear <sup>⊙</sup>	Trans- mission	High Speed	235 Engine 6822	
		Speed	261 Engine 7522	
			V8 Engine 7697	
			V8 Engine 8449	
		Low Speed	235 Engine 9304	
			261 Engine 10258	
V8 Engine 10496				
Drive and Torque taken through		Springs (Hotchkiss)		
Gear backlash		.005-.008		
Lubricant Capacity		16 pints		
Anti-friction Bearings		See pages 150-153		

\* - Rear axle ratio x transmission low ratio.

⊙ - Total gear reduction x engine maximum net torque x efficiency factor (.85).

¢ - Gear change points for 8.25-20 tires and 6.40/8.72:1 axle ratio.

3-25-55

UNIVERSAL JOINTS AND PROPELLER SHAFTS

SERIES 31-32-34-3600

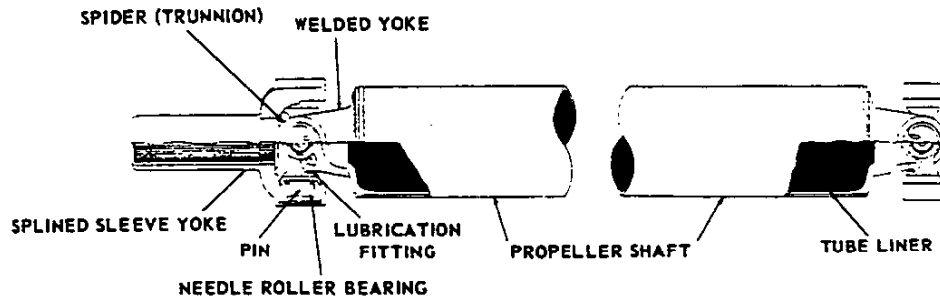

ITEM		3100		3200		3400		
		3-Speed Overdrive Automatic	3-Speed H. D. 4-Speed	3-Speed Overdrive Automatic	3-Speed H. D. 4-Speed	3-Speed Automatic	3-Speed H. D. 4-Speed	
Type and material	Propeller Shaft	Tubular Steel						
	U-Joints & Trunnion	Yoke & trunnion, Drop forged steel; trunnion case hardened						
Propeller shaft	Number Used	1		2		1		
	Outside dia	Front			2.5			
		Intermediate						
		Rear	3.0	3.5	2.5	3.5		
	Wall thickness	Front			.080-.088			
		Intermediate						
Rear		.062-.068		.080-.088		.062-.068		
U-Joint	Number Used	2		3		2		
	Rated Capacity (lb ft)	Front	600	2080	600	2080	600	2080
		Front Inter.			2080			
		Rear Inter.						
		Rear	600				2080	
Anti-friction bearings See pages 148-151	Support Bearings			1				
	Trunnion Bearings	One set of needle bearings for each trunnion pin						

ITEM		35-3700			3600			
		3-Speed	Automatic	3-Speed H. D. 4-Speed	3-Speed	Automatic	3-Speed H. D. 4-Speed	
Type and material	Propeller Shaft	Tubular Steel						
	U-Joints & Trunnion	Yoke & trunnion, Drop forged steel; trunnion case hardened						
Propeller Shaft	Number Used	2		1		2		
	Outside dia	Front	2.5				2.5	
		Intermediate						
		Rear	2.5		3.5		2.5	
	Wall thickness	Front	.080-.088				.080-.088	
		Intermediate						
Rear		.080-.088		.062-.068		.080-.088		
U-Joint	Number Used	3		2		3		
	Rated Capacity (lb ft)	Front	600	2080	600	2080		
		Front Inter.						
		Rear Inter.	2080				2080	
		Rear			2080			
Anti-friction bearings See pages 148-151	Support Bearings	1				1		
	Trunnion Bearings	One set of needle bearings for each trunnion pin						

3-25-55



**UNIVERSAL JOINTS AND PROPELLER SHAFTS**

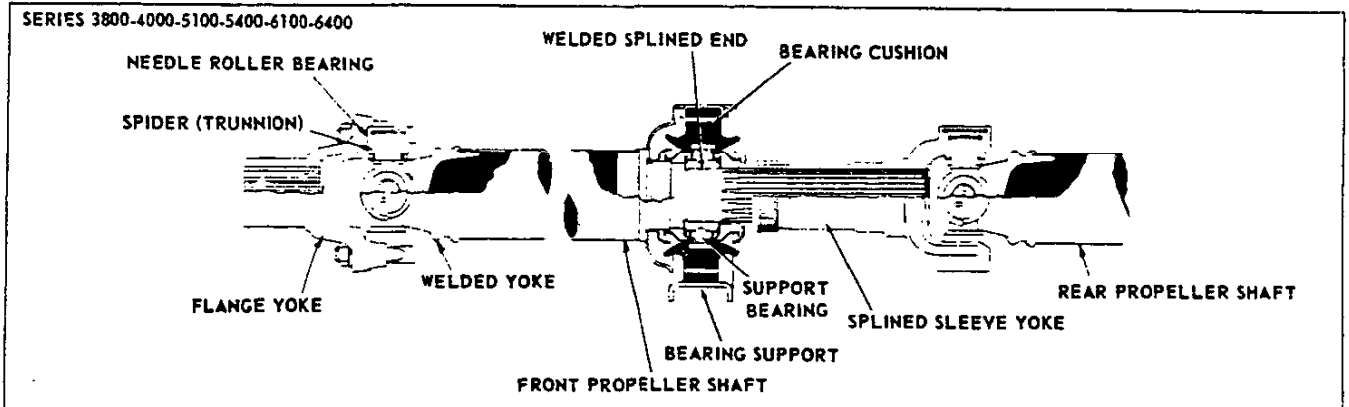

ITEM		3800		41-6100		44-45-6400		51-5400	
		3-Speed H. D. 4-Speed	Automatic	4-Speed	4-Speed With H. D. Sgl or 2-Spd Rear Axle	4-Speed	4-Speed With H. D. Sgl or 2-Spd Rear Axle	4-Speed	
Type and material	Propeller Shaft	Tubular Steel							
	U-Joint & Trunnion	Yoke and trunnion, Drop forged steel; Trunnion case hardened							
Propeller Shaft	Number Used	2							
	Outside dia	Front	2.5		3				
		Intermediate							
		Rear	2.5	3.0	2.5	3.0			
	Wall thickness	Front	.080-.088						
Intermediate									
Rear		.080-.088							
U-Joint	Number Used	3							
	Rated Capacity (lb ft)	Front	2080	2500	2080	2500			
		Front Inter.							
		Rear Inter.	2080	2500	2080	2500			
		Rear	2080	2500	2080	2500			
Anti-friction bearings See pages 148-151	Support Bearings	1							
	Trunnion Bearings	One set of needle bearings for each trunnion pin							
Propeller Shaft Guard	Number Used						2(4500 only)		
	Type	U-Bolt							
	Material	.625 Round Steel							
	Location	At front of each shaft							

ITEM		5700		6500		6700		6800	
		4-Speed	4-Speed	4-Speed With H. D. Sgl or 2-Spd Rear Axle	4-Speed	4-Speed With H. D. Sgl or 2-Spd Rear Axle	4-Speed	4-Speed With H. D. Sgl or 2-Spd Rear Axle	
Type and material	Propeller Shaft	Tubular Steel							
	U-Joint & Trunnion	Yoke and trunnion, Drop forged steel; Trunnion case hardened							
Propeller Shaft	Number Used	3							
	Outside dia	Front	3.0	2.5	3.0				
		Intermediate	3.0	2.5	3.0	2.5	3.0		
		Rear	3.0	2.5	3.0	2.5	3.0		
	Wall thickness	Front	.080-.088						
Intermediate		.080-.088							
Rear		.080-.088							
U-Joint	Number Used	4							
	Rated Capacity (lb ft)	Front	2500	2080	2500	2080	2500	2080	2500
		Front Inter.	2500	2080	2500	2080	2500	2080	2500
		Rear Inter.	2500	2080	2500	2080	2500	2080	2500
		Rear	2500	2080	2500	2080	2500	2080	2500
Anti-friction bearings See pages 148-151	Support Bearings	2							
	Trunnion Bearings	One set of needle bearings for each trunnion pin							
Propeller Shaft Guard	Number Used	3							
	Type	U-Bolt							
	Material	.625 Round Steel							
	Location	At front of each shaft							

3-25-55

## DRIVE SYSTEM SPLINES - TRANSMISSION AND PROPELLER SHAFT

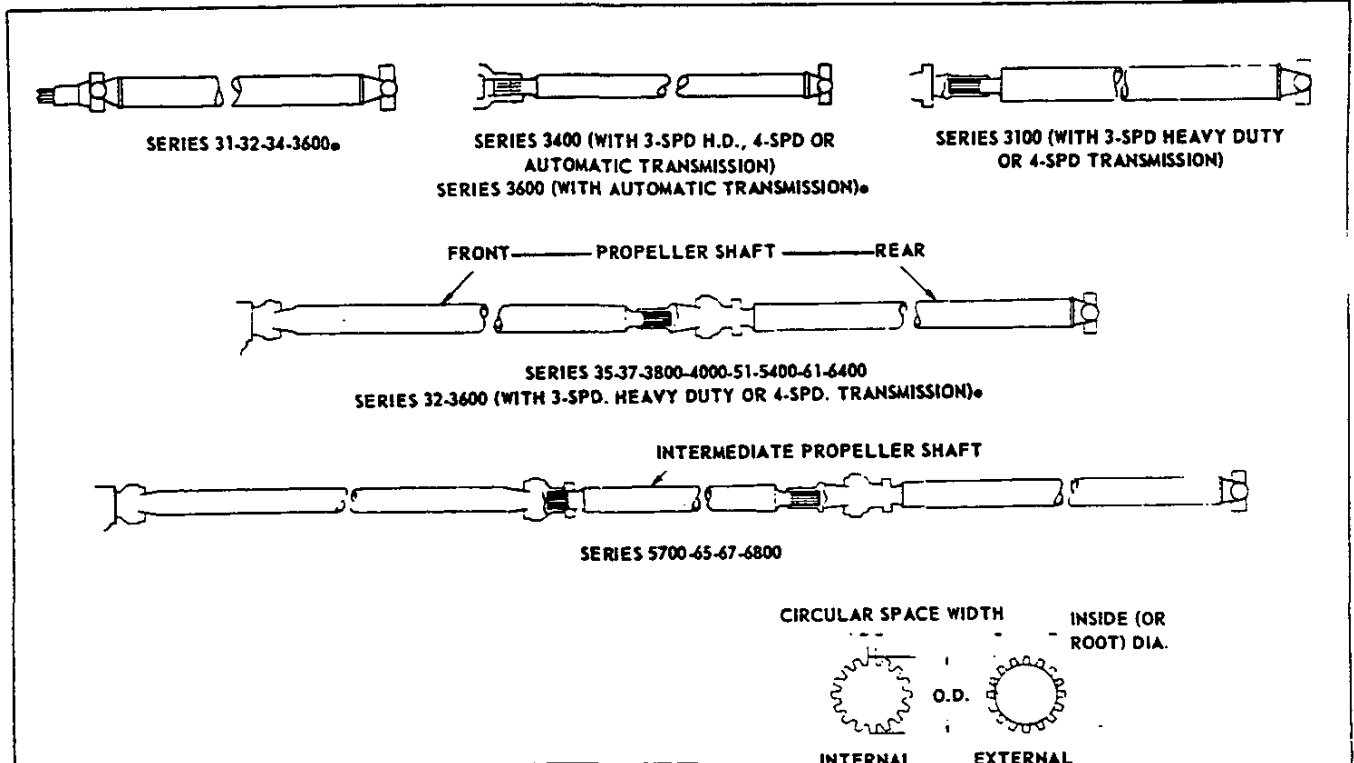

**CLUTCH DISC HUB AND TRANSMISSION CLUTCH GEAR SHAFT**

SERIES	ITEM	INTERNAL	EXTERNAL
3000-4000	Width	.174-.176	.171-.173
	I. D.	.920-.925	.918 max eff
5000-6000	O. D.	1.134-1.144	1.110-1.121
	Splines	10 (Straight side)	

**TRANSMISSION MAINSHAFT AND FRONT U-JOINT FRONT SLEEVE YOKE**

SERIES	ITEM	INTERNAL	EXTERNAL
31-3200 (with 3-spd conv; O. D. or auto. trans) 34-35-36-3700 (with 3-speed trans)	Width	.1135-.1150	.1095-.1130
	I. D.	1.034-1.039	.9390-.9490
	O. D.	1.1755-1.1765	1.1745-1.1750
	Splines	16 (Straight side)	

**PROPELLER SHAFT FRONT END AND FRONT U-JOINT REAR SLEEVE YOKE**

SERIES	ITEM	INTERNAL	EXTERNAL
31-3400 (with 3-spd HD or 4-spd trans) 34-35-3600 (with auto. trans)	Width	.1455-.1470	.1430-.1445
	I. D.	1.295-1.300	1.281-1.286
	O. D.	1.495-1.500	1.4975-1.4980
	Splines	16 (Straight side)	

**INTERMEDIATE PROPELLER SHAFT REAR END AND U-JOINT FRONT SLEEVE YOKE**

SERIES	ITEM	INTERNAL	EXTERNAL
5700 65-67-6800	Width	.1335-.1350	.1305-.1320
	I. D.	1.182-1.187	1.168-1.175
	O. D.	1.374-1.375	1.3725-1.3730
	Splines	16 (Straight side)	

**TRANSMISSION MAINSHAFT AND FRONT U-JOINT FRONT FLANGE**

SERIES	ITEM	INTERNAL	EXTERNAL
3000 (with 3-spd HD or 4-spd trans) 34-35-36-37-3800 (with auto. trans) 4-5-6000 (with 4-spd trans)	Width	.1964-.1979	.1939-.1954
	I. D.	1.155-1.158	1.123-1.125
	O. D.	1.373-1.376	1.350-1.360
	Splines	10 (Involute)	

**FRONT PROPELLER SHAFT REAR END AND U-JOINT FRONT SLEEVE YOKE**

SERIES	ITEM	INTERNAL	EXTERNAL
32-35-3600 (with 3-spd HD or 4-spd trans) 37-38-4000 5100-5400 6100-6400	Width	.1335-.1350	.1305-.1320
	I. D.	1.182-1.187	1.168-1.175
	O. D.	1.374-1.375	1.3725-1.3730
	Splines	16 (Straight side)	

**FRONT PROPELLER SHAFT REAR END AND U-JOINT FRONT FLANGE**

SERIES	ITEM	INTERNAL	EXTERNAL
5700 65-67-6800	Width	.2130-.2145	.2125-.2140
	I. D.	1.208-1.213	1.120-1.130
	O. D.	1.374-1.375	1.372-1.373
	Splines	10 (Straight side)	

3-25-55. Revised: 8-1-55, a-Data Revised  
CHEVROLET 1955 SPECIFICATIONS - TRUCK

DRIVE SYSTEM SPLINES - REAR AXLE

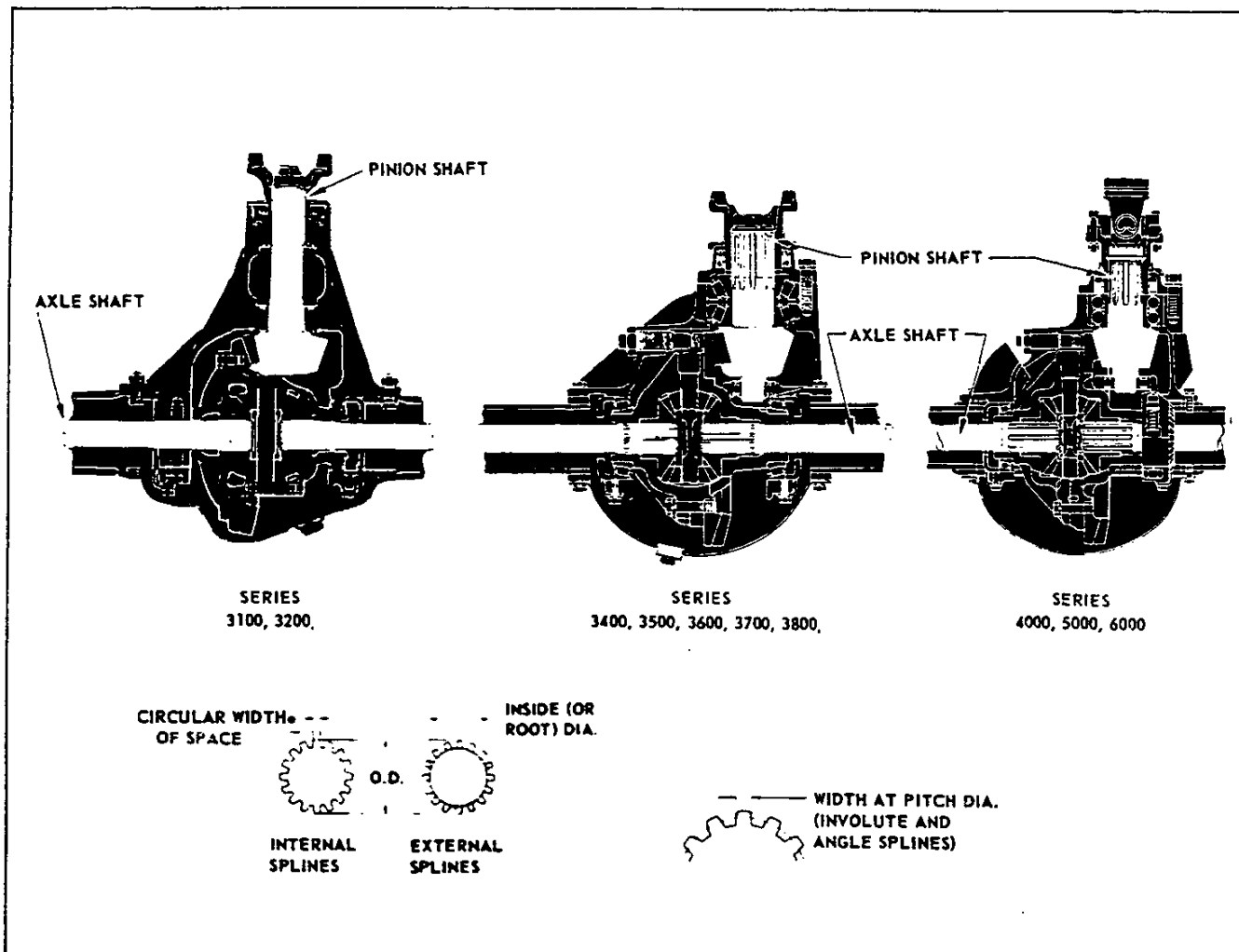

PROPELLER SHAFT PINION FLANGE AND REAR AXLE DRIVE PINION SHAFT

SERIES	ITEM	INTERNAL	EXTERNAL
3100-3200	Width	.1144-.1154	.1124-.1144
	I. D.	1.194-1.198	1.156-1.164
	O. D.	1.3117-1.3132	1.3092-1.3107
	Splines	17 (Involute)	
3400-3500	Width	.302-.303	.300-.302
3600-3700	I. D.	1.694-1.702	1.637-1.647
3800-4000	O. D.	1.9675-1.9755	1.941-1.942
5000-6000	Splines	10 (Straight side)	

DIFFERENTIAL SIDE GEAR AND AXLE SHAFT

SERIES	ITEM	INTERNAL	EXTERNAL
3100-3200	Width	.1144-.1154	.1124-.1144
	I. D.	1.194-1.198	1.166-1.174
	O. D.	1.3005-1.3105	1.2795-1.2845
	Splines	17 (Involute)	
3400-3500	Width	.1499-.1509	.1479-.1499
3600-3700	I. D.	1.4245-1.4285	1.399-1.407
3800	O. D.	1.5485-1.5595	1.5275-1.5325
4000	Splines	17 (Involute)	
	Width	.1001-.1011	.098-.100
	I. D.	1.628-1.632	1.565-1.569
	O. D.	1.752-1.756	1.724-1.732
5000-6000 (4000 with RPO 2-Spd Axle)	Splines	27 (Involute)	
	Width	.1001-.1011	.0981-.1000
	I. D.	1.752-1.756	1.689-1.693
	O. D.	1.876-1.880	1.848-1.856
	Splines	29 (Involute)	

AXLE SHAFT FLANGE AND REAR WHEEL HUB

SERIES	ITEM	INTERNAL	EXTERNAL
4000	Width	.3106-.3116	.3086-.3106
	I. D.	3.295-3.305	3.245-3.255
	O. D.	3.795-3.805	3.765-3.775
	Splines	20 (Involute)	
5000-6000 (4000-with RPO 2 Spd Axle)	Width	.157-.158	.155-.157
	I. D.	3.910-3.915	3.860-3.870
	O. D.	4.213-4.218	4.185-4.195
	Splines	40 (Involute)	

**BRAKES**

ITEM			3100 3200	3600	3400 3500 3700	3800 (RPO 3400- 3500-3700)	4000	5000	6000		
Service Brake (Hy- draulic)	Type	Front	Servo-type, Single anchor								
		Rear	2-cyl. balanced, Four anchor								
	Drum	Type	Front	Composite. Cast alloy iron							
			Rear	rim, pressed steel web							
				One-piece, cast alloy iron							
		Dia (Front & Rear)		11	12	12 & 14	14 & 15				
		Total area in sq. in. (effective)	Front	138	151	151	220				
		Rear	121	151	220	377					
		Total	259	302	371	597					
	Lining	Material		Full molded asbestos composition							
		Width	Front	2	2	2	2.5				
			Rear	1.75	2	2.5	4				
		Thickness after grinding §	Front	.164-.175	.248-.252				.373-.377		
			Rear								
		Adjust to slight drag and:	Front	Back off 7 notches	Back off enough to eliminate drum drag, but no more than 7 notches				Back off 1 to 2 notches		
			Rear								
		Attachment		Bonded				Riveted			
		Lining area in sq. in. (effective)	Front	84	93	93	134				
			Rear	74	93	137	241				
	Total		158	186	230	375					
	Wheel Cylinder	No. of Cylinders	Front	2				2			
			Rear	2				4			
		Diameter	Front	1.125				.875			
Rear			1.0	1.125	1.25	1.50					
Piston travel		.349	.312	.280	.185						
Main Cylinder	Model #		341-M				361-S				
	Diameter		1.125				1.25				
	Piston travel		1.25				1.25				
Braking effort	Front	56%	50%	41%	24%						
	Rear	44%	50%	59%	76%						
Pedal & cylinder ratio	Pedal ratio		6.352								
	Cyl. area ratio		3.579	4.000	4.469	6.740					
	Overall		22.734	25.408	28.387	42.812					
Foot pedal	Travel		7.940								
	Pad cover		Molded rubber								
Brake fluid capacity			Approximately 1 pint								
Brake fluid recommended			Delco, Super #11								
Parking Brake (Mech- anical)	Type (See note below)		Rods & cables to rr wheels			Drum on prop shaft					
	Actuated by		Hand Lever								
	Control location		L.H. side				On floor, R.H. side of				
			Below instrument panel				gearshift control lever				
	Drum	Diameter	11	12	8	9.5 Inner, 10 Outer					
		Area (effective)	121	151	62.75	138					
	Lining	Material		Full molded asbestos composition							
Clearance			See adjustment for rear service brakes				.010-.015				
Area (effective)		74	93	61.5	35						
				(Band type)	(Dual shoe type)						

**POWER BRAKES**

ITEM		RPO 34-35-3742 31-32-36-3800	RPO 4000	Reg Prod. 5000-6000	RPO 5000-6000
Type		Single piston, Vacuum suspended			
Power cylinder diameter		6.75			9.5
Vacuum cylinder stroke		1.5	3.906		4.734
Control valve		Reactionary type			
Power distribution @ 1000 PSI line press	Pedal	63% e	35% x		15% x
	Booster	37% e	65% x		85% x
Vacuum reserve tank (RPO 281)	Size	24 long x 7.5 I. D.			
	Capacity	1000 cu. in.			
	Location	Clamped to outside of left side rail			

Note: Band type propeller shaft parking brake, similar to that on 3800 series trucks, replaces rod and cable type when RPO transmissions are used on all 3400-3500-3600-3700 models.

3-25-55. Revised: 8-1-55. e- Data added, x-Data corrected, §-Data revised.  
CHEVROLET 1955 SPECIFICATIONS - TRUCK

**ENGINE - GENERAL**

Basic Engine Data

ITEM	3100	3600	3800	4100	4502	3400	3500	3700	4000 RPO	6702	6000 RPO			
	3200			4400					6000 Reg	6802				
Piston displacement	235.5 cu. in.										261 cu. in.			
Bore and Stroke (Nominal)	3.563 x 3.938										3.75 x 3.938			
Type	Valve-in-head, 6-cylinder													
Compression ratio	7.5:1										7.17:1			
Taxable (SAE) horsepower	30.4										33.7			
Idling speed	475 RPM													
Comp. pressure (Engine hot)	130 PSI or better at cranking speed													
Dry Weight (Pounds)	Engine and clutch		606		611	616	*	*	*	612	616	626		
	With transmission		672		671	753	771	775	*	*	*	771	775	785
Governor equipment	RPO 241						RPO 241							
Governor speed (RPM)	2300-3200								2300-3200		2400-3400			
	1650-2500								1650-2500		1650-2400			

\* - Information not available

**ADVERTISED MAXIMUM ENGINE PERFORMANCE**

ITEM		31-32-36-3800, 4000	34-35-3700	6000 (4000 RPO)	RPO 6000
Horsepower @ RPM	Gross	123 @ 3800	119 @ 3600	123 @ 3800	140 @ 4000
	Net	109 @ 3600	105 @ 3600	109 @ 3600	123 @ 3800
Torque (ft lb) @ RPM	Gross	207 @ 2000	205 @ 2000	207 @ 2000	230 @ 2000
	Net	195 @ 2000	188 @ 2000	195 @ 2000	215 @ 2000

**ENGINE SPEED AND PISTON TRAVEL #**

Series	Tire Size	Axle Ratio	Transmission Type	Engine RPM at one MPH				Piston Travel (ft/mi) 235.5 Eng and 261 Eng	Crankshaft (rev/mile)	
				Low	2nd	3rd	High			
3100 3200	6.70-15	3.9:1	3-Speed	144	82	49		1930	2941	
			4-Speed	346	175	84	49			
			3-Speed Heavy-Duty	155	86	49				
		4-Speed Automatic	187	120	71	49				
		Overdrive Locked out	152	87	52		2034			3099
		Locked in	106	61	36		1423			2169
	6.50-16	3.9:1	3-Speed	136	79	47		1848	2816	
			4-Speed	331	168	80	47			
			3-Speed Heavy-Duty	140	82	47				
		4-Speed Automatic	170	123	68	47				
		Overdrive Locked out	145	83	49		1947			2967
		Locked in	102	58	35		1363			2077
	15	3.9:1	3-Speed	134	77	46		1797	2738	
			4-Speed	322	163	78	46			
			3-Speed Heavy-Duty	145	81	46				
		4-Speed Automatic	174	120	66	46				
Overdrive Locked out		141	81	48		1893	2885			
Locked in		99	57	34		1326	2020			
3600	15	4.57:1	3-Speed	157	90	53		2105	3208	
			4-Speed	377	191	91	53			
			3-Speed Heavy-Duty	160	94	53				
			4-Speed Automatic	252	102	83	53			

3-25-55

118 - ENGINE, SIX CYLINDER

CHEVROLET 1955 SPECIFICATIONS - TRUCK

ENGINE - GENERAL - Continued

Series	Tire Size	Axle Ratio	Transmission Type	Engine RPM at one MPH				Piston Travel (Ft/mi) 235.5 Eng and 261 Eng	Crankshaft (rev/mile)			
				Low	2nd	3rd	High †					
3600	6.50-16	4.57:1	3-Speed	162	92	55		2166	3300			
			4-Speed	388	197	94	55					
			3-Speed Heavy-Duty	174	96	55						
			4-Speed Automatic	259	167	86	55					
	3-Speed		143	82	49		1916	2920				
	4-Speed		344	174	83	49						
	3-Speed Heavy-Duty		154	85	49							
	4-Speed Automatic		229	147	76	49						
	3-Speed	139	79	47		1857	2829					
	4-Speed	333	169	81	47							
	3-Speed Heavy-Duty	149	83	47								
	4-Speed Automatic	222	143	74	47							
3400 3500 3700 3800%	7.00-17	5.14:1	3-Speed	161	92	55		2155	3284			
			4-Speed	386	196	94	55					
			3-Speed Heavy-Duty	174	96	55						
			4-Speed Automatic	258	166	85	55					
	3-Speed		156	89	53		2088	3182				
	4-Speed		374	190	91	53						
	3-Speed Heavy Duty		168	93	53							
	4-Speed Automatic		250	161	83	53						
	3-Speed	156	89	53		2091	3187					
	4-Speed	374	190	91	53							
	3-Speed Heavy-Duty	168	93	53								
	4-Speed Automatic	250	161	83	53							
4000	6.50-20	6.17:1	4-Speed	437	222	106	62	2437	3714			
	7.00-20			425	215	103	60	2368	3609			
	7.50-20			410	208	99	58	2288	3486			
	6.50-20			5.83:1	413	209	100	58	2303	3510		
				7.95:1	563	286	136	80	3141	4786		
	7.00-20			5.83:1	401	203	97	57	2238	3411		
				7.95:1	547	277	132	78	3052	4651		
	7.50-20			5.83:1	388	197	94	55	2162	3294		
				7.95:1	528	268	128	75	2948	4492		
	7.50-20			6.17:1	4-Speed	410	208	99	58	2288	3486	
	8.25-20					394	200	95	56	2198	3350	
	9.00-20					379	192	92	54	2110	3215	
7.50-20	7.20:1	479	243			116	68	2670	4068			
8.25-20		460	233			111	65	2566	3910			
9.00-20		442	224			107	62	2462	3751			
7.50-20		5.83:1	388			197	94	55	2162	3294		
6000	7.50-20	6.17:1	4-Speed			529	268	128	75	2948	4492	
						7.95:1	372	188	90	53	2078	3166
	8.25-20					7.95:1	508	258	123	72	2833	4317
							7.95:1	357	181	87	51	1993
	9.00-20					7.95:1	488	247	118	69	2718	4142
				7.95:1	426		216	103	60	2373	3616	
	7.50-20			8.72:1	580	294	140	82	3233	4927		
					8.72:1	409	207	99	58	2280	3475	
	8.25-20			8.72:1	557	283	135	79	3107	4735		
					8.72:1	392	199	95	56	2188	3334	
	9.00-20			8.72:1	534	271	129	76	2981	4543		

‡ - Engine RPM is determined by locating the figure for one mile per hour and multiplying by the desired miles per hour-MPH is determined by dividing the known engine RPM by the engine RPM for one mile per hour.  
 † - Also known as N/V factor. % - 3-Speed not available on 3800. +- 3800 only.

3-25-55

## ENGINE PERFORMANCE

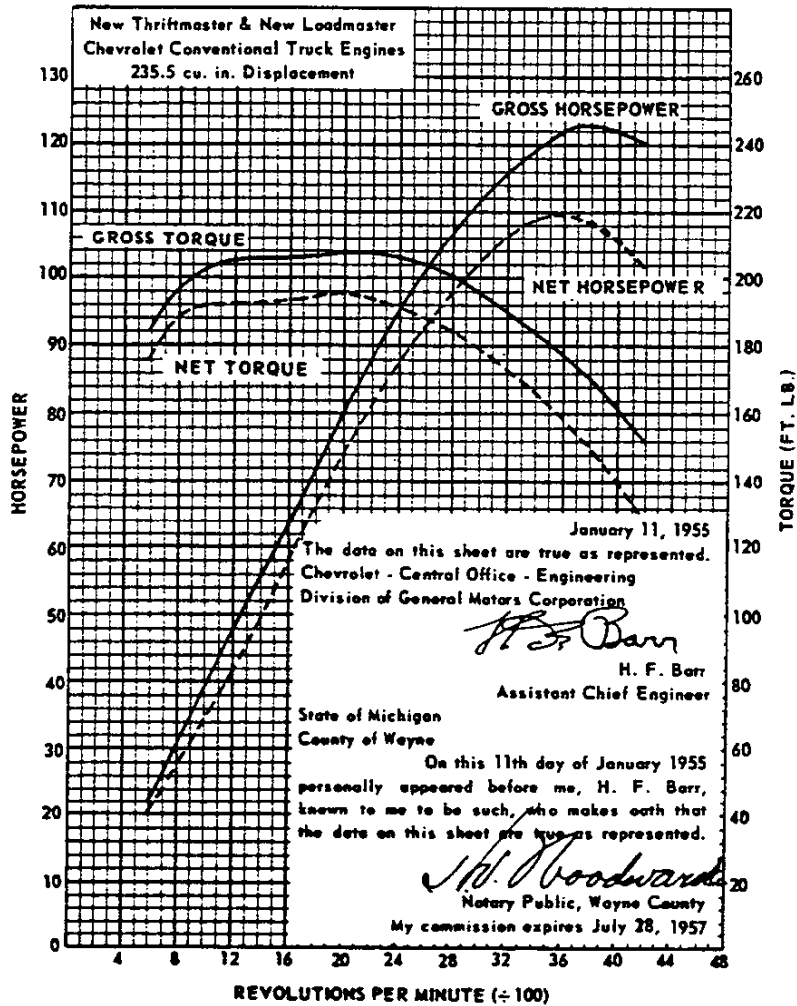

The engine performance curves shown on this sheet are taken from Chevrolet engine test report 16926-80. They represent the full throttle performance of a New Thriftmaster and New Loadmaster Chevrolet six cylinder truck engine (235.5 cu. in. displacement) as obtained from dynamometer test data which were corrected to the standard barometric pressure 29.92" mercury and the standard temperature of 60° F.

regular dynamometer test with the dynamometer exhaust system, no fan, generator not charging, and optimum spark advance.

NET POWER and TORQUE were obtained from a dynamometer test simulating actual operating conditions when the engine is in its vehicle. It includes the use of the regular muffler and pipes, the fan in operation and automatic spark advance. The generator is not charging.

GROSS POWER and TORQUE were obtained in a  
3-25-55  
120 - ENGINE, SIX CYLINDER

CHEVROLET 1955 SPECIFICATIONS - TRUCK

## ENGINE PERFORMANCE

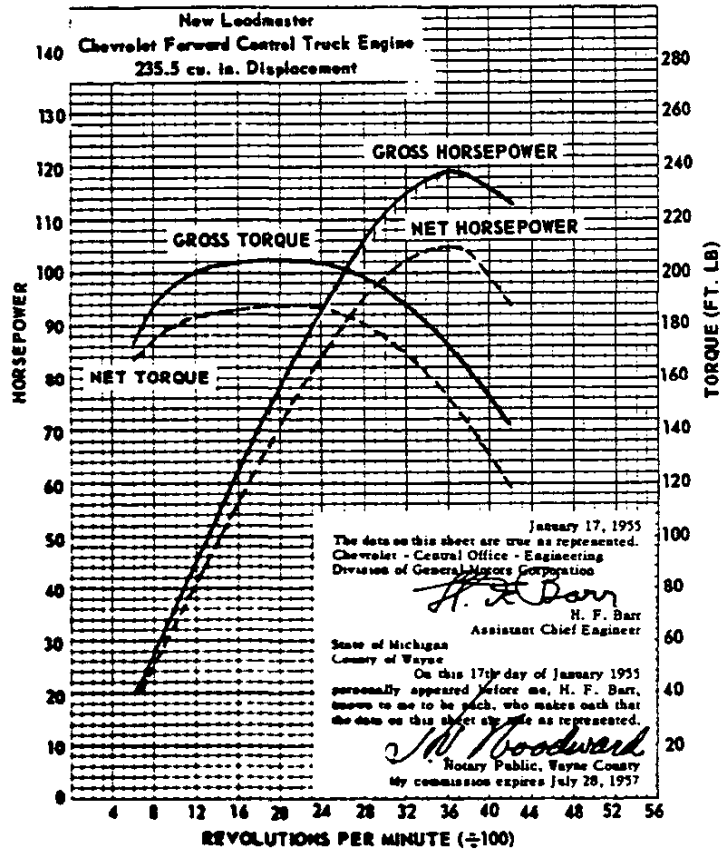

The engine performance curves shown on this sheet are taken from Chevrolet engine test report 16926-80. They represent the full throttle performance of a Chevrolet Forward Control six cylinder truck engine (235.5 cu. in. displacement) as obtained from dynamometer test data which were corrected to the standard barometric pressure 29.92" mercury and the standard temperature of 60° F.

regular dynamometer test with the dynamometer exhaust system, no fan, generator not charging, and optimum spark advance.

NET POWER and TORQUE were obtained from a dynamometer test simulating actual operating conditions when the engine is in its vehicle. It includes the use of the regular muffler and pipes, the fan in operation and automatic spark advance. The generator is not charging.

GROSS POWER and TORQUE were obtained in a  
3-25-55  
CHEVROLET 1955 SPECIFICATIONS-TRUCK

ENGINE, SIX CYLINDER-121



## ENGINE PERFORMANCE

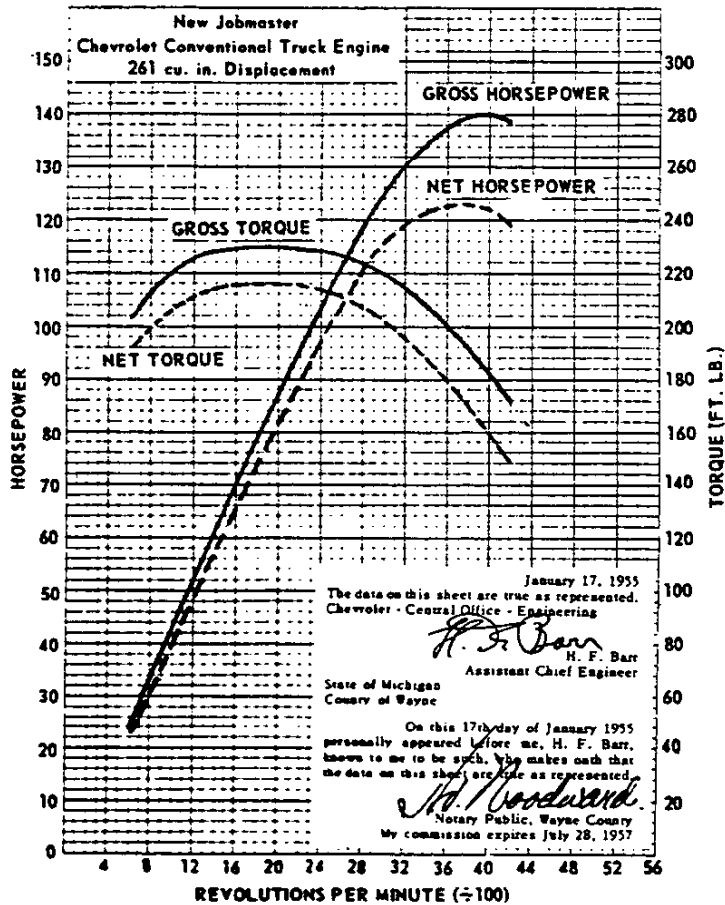

The engine performance curves shown on this sheet are taken from Chevrolet engine test report 16670-135C. They represent the full throttle performance of a New Jobmaster Chevrolet six cylinder conventional truck engine (261 cu. in. displacement) as obtained from dynamometer test data which were corrected to the standard barometric pressure 29.92" mercury and the standard temperature of 60° F.

GROSS POWER and TORQUE were obtained in a 3-25-55  
122-ENGINE, SIX CYLINDER

regular dynamometer test with the dynamometer exhaust system, no fan, generator not charging, and optimum spark advance.

NET POWER and TORQUE were obtained from a dynamometer test simulating actual operating conditions when the engine is in its vehicle. It includes the use of the regular muffler and pipes, the fan in operation and automatic spark advance. The generator is not charging.

### CYLINDER CASE AND HEAD

Material ----- Cast alloy iron      Bore diameter: 3.5620-3.5640  
 Cylinder head bolt torque ----- 90-95 ft lb      235.5 Engine  
 Offset ----- None      261.0 Engine ----- 3.7490-3.7510

### CRANKSHAFT AND BEARINGS

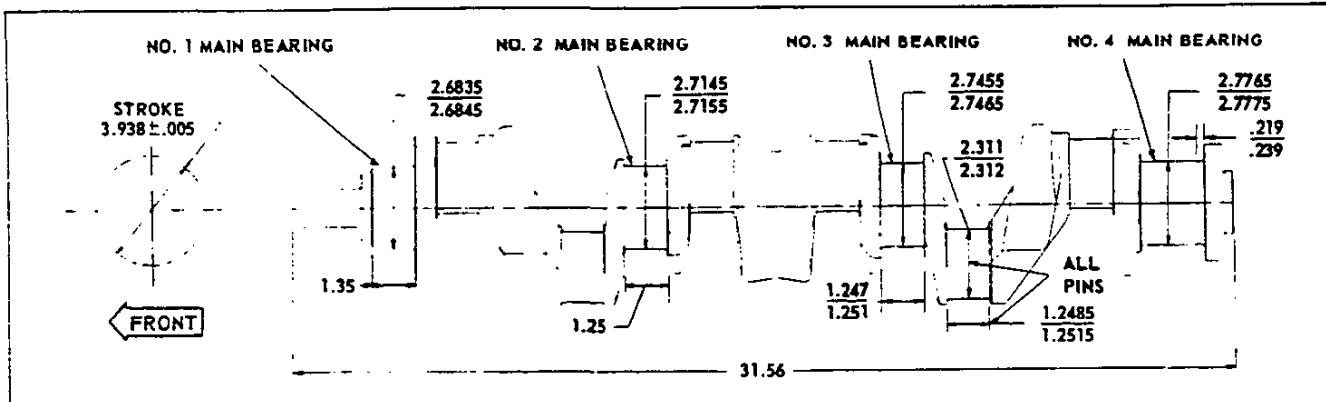

CRANKSHAFT

Material ----- Drop-forged steel  
 Weight (Crankshaft & pilot bearing assembly) - 80 lb  
 End play ----- .0035-.0095  
 Counter weights ----- 7  
 Stroke: ----- 3.938 ± .005

MAIN BEARINGS

Type ----- Precision, removable  
 Removable ----- From below  
 Necessary to align ream ----- No  
 Clearance ----- .0004-.0025 fit with solid shims  
 End thrust against ----- #3 bearing  
 Bearing cap bolt torque ----- 100-110 ft lb with oiled threads

Brg	Theo I. D. $\phi$	Eff Length $\zeta$	Proj Area $\S$
#1	2.6855	1.063	2.855 sq. in.
#2	2.7165	.907	2.464 sq. in.
#3	2.7475	.968	2.658 sq. in.
#4	2.7785	1.189	3.304 sq. in.

$\phi$  - Journal diameter plus clearance

$\zeta$  - Overall length minus chamfers

$\S$  - Based on theoretical I. D. and effective length

### HARMONIC BALANCER

(Vibration damper)

Type ----- Oscillating (Rubber-Coated)

Crankshaft pulley:

Pitch diameter ----- 2.64

### CAMSHAFT AND BEARINGS

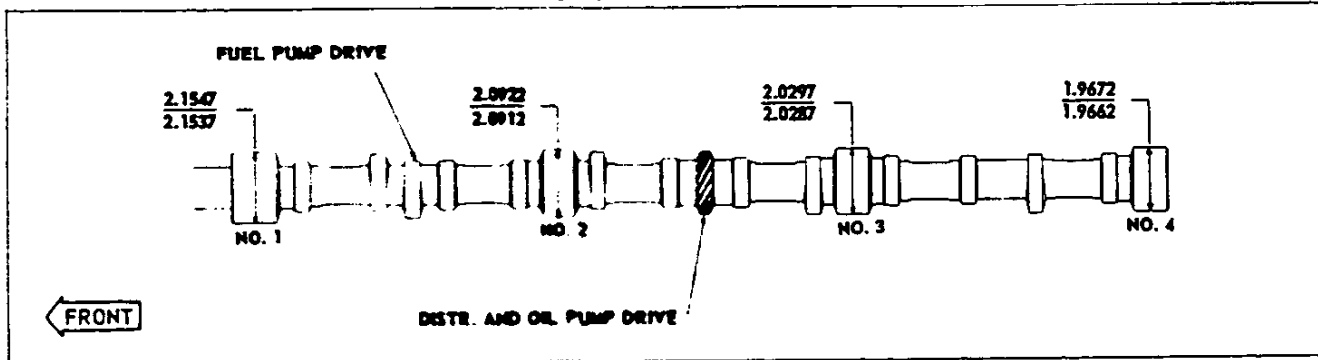

CAMSHAFT

Material ----- Cast alloy iron  
 End play ----- .001-.002  
 Thrust taken by ----- Thrust taken between driver timing gear and camshaft #1 journal front face

Ramp: Inlet

235.5-Opening Closing ----- .0111, 28° long

261.0-Opening ----- .0085, 18° long

Closing ----- .0107, 30° long

Ramp: Exhaust

235.5-Opening & Closing ----- .0140, 36° long

261.0-Opening ----- .0147, 30° long

Closing ----- .0148, 37° long

### DRIVE

Make and type ----- Own, helical gear

Material:

Driven gear (Camshaft) ----- Aluminum alloy

Drive gear (Crankshaft) ----- Steel

### BEARING

Material ----- Steel-backed babbitt

Clearance on diameter ----- .0010-.0030

Brg	Rear dia	Overall length	Proj Area $\text{O}$
#1	2.1562	1.12	2.415 sq.in.
#2	2.0937	.94	1.968 sq.in.
#3	2.0312	.94	1.909 sq.in.
#4	1.9687	.94	1.846 sq.in.

$\text{O}$  - Based on rear diameter and overall length as shown above.

PISTON - PIN - RINGS

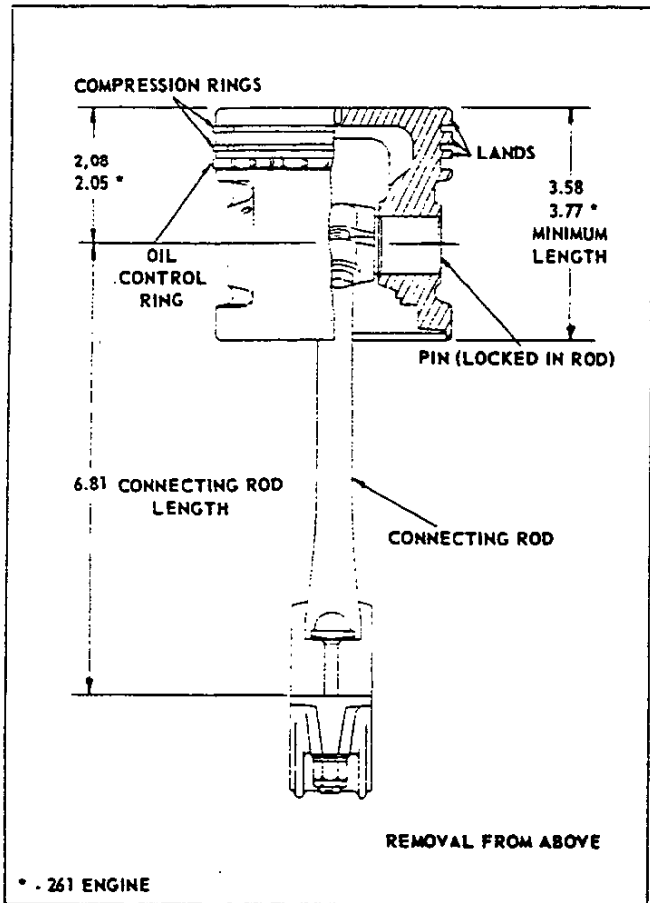

PISTON

Make	----- Own
Material	----- Cast alloy aluminum with steel struts
Features	----- Flat head tin plated, oval with controlled thermo expansion
Skirt clearance in cylinder bore	----- .0005-.0011
235.5 Engine	
Land clearance in cylinder bore	----- .028-.036
Compression and oil ring groove depth	----- .199-.205
Holes, number and size	----- 8, .156 drill
Head thickness at center	----- .235-.245
Piston pin bushings	----- None
Weight of piston	----- 1.18 lb
Weight of piston, rings, pin and connecting rod upper end x 6 (Units/engine)	----- 12.50

CONNECTING RODS

Type	----- Rod clamps piston pin
Material	----- Drop-forged steel
Rod width at piston pin	----- 1.126-1.129
Rod width at crankpin	----- 1.2415-1.2435
Crankpin bearings:	
Type	----- Precision interchangeable insert
Material	----- Steel backed, thin wall babbitt
Diameter	----- 2.3127-2.3138
Effective length overall lengthless chamfers	----- 1.008
Clearance on diameter	----- .0007-.0028
Projected area per rod (based on effective length)	----- 2.332 sq. in

261 Engine:

Compression ring groove depth	----- .208-.214
Oil groove:	
Depth	----- .204-.210
Holes, number and size	----- 8, .156 drill
Head thickness at center	----- .255-.265
Weight of piston	----- 1.36 lb
Weight of piston, rings, pin, and connecting rod upper end x 6 (Units/engine)	----- 14.53 lb

PISTON PIN

Material	----- Chromium steel (file hard case)
Diameter: 235.5	----- .8660-.8665
261	----- .9270-.9275
Length: 235.5	----- 3.168-3.198
261	----- 3.355-3.385
Taper limit in full length	----- .0002
Weight: 235.5	----- .320
261	----- .375
Clearance in piston	----- .00015-.00025

COMPRESSION RINGS

Number per piston	----- 2
Type	----- Thick wall inside bevel
Material	----- Cast iron (235.5 Loadmaster and 261 Jobmaster upper ring only)
Width	----- .0930-.0935
Gap clearance:	
235.5	----- .007-.017
261	----- .010-.020
Ring clearance in groove	----- .0020-.0035
Wall Thickness	----- 235.5 .168-.178
261.0	----- .177-.187

OIL RINGS

Material and type	----- Steel, multi-piece, 2 rails and spacer
Upper and lower rails	----- Flat spring or scaleless tempered steel, full chrome plated Q.D.
Spacer (between rails)	----- Flat spring steel
Gap clearance (on rails)	----- .015-.055
Ring clearance in groove	----- .000-.008
Width	----- .181-.188
Max. wall thickness (rails)	----- 235.5 .153
261.0	----- .168
Weight: Spacer	----- .020
Segment (Each)	----- .022

Assembly weight 235.5	----- 1.99 lb
261	----- 2.09 lb
Upper end weight: 235.5	----- .454 lb
261	----- .544 lb
Lower end weight: 235.5	----- 1.54 lb
261	----- 1.55 lb
Total rotating weight of connecting rods (weight of lower end x 6): 235.5	----- 9.22 lb
261	----- 9.28 lb
End play	----- .005-.010
Recommended nut torque, with oiled threads	----- 35 to 45 ft lb

VALVE TRAIN

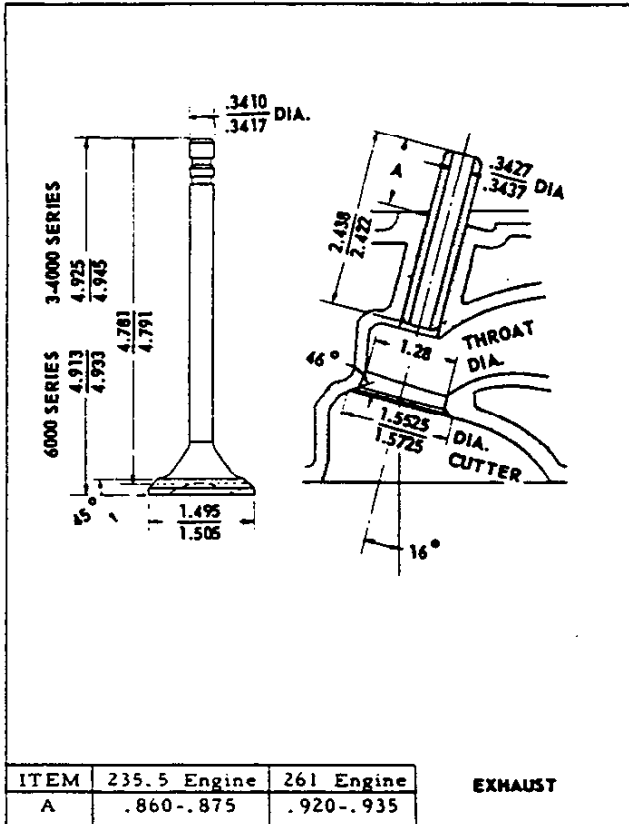

VALVES

Make ----- Own  
 Material: Exhaust valve  
 • Thriftmaster --- Aluminum dipped, Silcrome steel  
 Loadmaster & Jobmaster --- Silcrome XCR steel  
 Inlet valve ----- Silcrome or Nickel-chrome steel  
 Stem and style ----- Grooved for keys and oil seal  
 Lift:  
 Exhaust valve (235.5 Engine) ----- .3118  
 261 Engine ----- .4143  
 Inlet valve (235.5 Engine) ----- .2941  
 261 Engine ----- .4051  
 Face angle: Exhaust valve ----- 45°  
 Inlet ----- 30°  
 Distance between valve centers (measured along centerline of engine) ----- 1.547  
 Valve Lash: Inlet Exhaust  
 3-4000 Series (\* Engine normalized) .006 .016  
 6000 Series (\* Engine normalized) .006 .020  
 \* - To normalize engine (run it at fast idle approximately 600 RPM) until a constant oil temperature is maintained for a period of five minutes.  
 Exhaust valve rotators:  
 Loadmaster and Jobmaster --- Positive rotation type

TAPPETS

Type, material ----- Cylindrical, cast alloy iron  
 Outside diameter ----- .989-.990  
 Lift:  
 Exhaust (tappet) 235.5 Engine ----- .2111  
 261 Engine ----- .2805  
 Inlet (tappet) 235.5 Engine ----- .1991  
 261 Engine ----- .2743  
 Clearance ----- Selective fit  
 3-25-55. Revised: 8-1-55, e-Data revised.  
 CHEVROLET 1955 SPECIFICATIONS - TRUCK

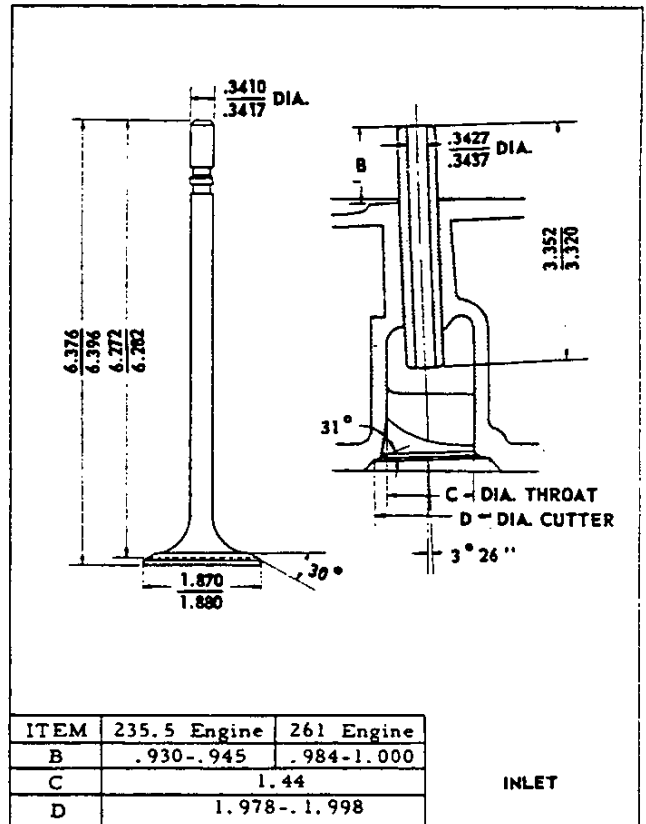

VALVE STEM GUIDES

Type ----- Removable  
 Clearance with stem: Exhaust ----- .001-.0027  
 Inlet ----- .001-.0027

VALVE ROCKER ARMS

Material ----- Cast malleable iron  
 Ratio (valve lift to cam lift) ----- 1.477:1  
 Torque of valve rocker shaft support bolts and nuts ----- 25-30 ft lb  
 Bearing: Type ----- Machined in rocker arm  
 Inside diameter ----- .7925-.7935  
 Length ----- .9354

VALVE SPRINGS

Length and pressure:  
 Valve closed (235.5 Engine) ----- 1.821 @ 62-68 lb  
 261 Engine ----- 1.858 @ 74-82 lb  
 Valve open (235.5 Engine) ----- 1.505 @ 155-165 lb  
 261 Engine ----- 1.462 @ 196-208 lb  
 Free length (235.5 Engine) ----- 2.156  
 261 Engine ----- 2.234

VALVE SEATS

Material ----- Cast alloy iron (Cylinder Head)  
 Inserts ----- None  
 Angle: Exhaust seat (In head) ----- 46°  
 Inlet seat (In head) ----- 31°  
 Width in head: Exhaust seat ----- .062-.093  
 Inlet seat ----- .035-.060

### ENGINE COOLING SYSTEM

Method of cooling cylinder walls - Full stroke length water jacket with water around each cylinder.

ITEM		31-3200	34-35-3700	3600	3800	4000	6000	6000 (261 Eng) *
Capacity (quarts)	Regular		17			18		17
	RPO 256	18.5				18.5		
Radiator Core	Make, type & Material		Harrison, cellular, copper					
	Size	Regular	.25 x .560 x 2		.22 x .560 x 2		.20 x .56 x 2.5	
		RPO 256	*		.20 x .560 x 2.5			
	Frontal area (sq. in.)	Regular	426				470	
RPO 256		470		470				
Pressure, cooling system		Radiator cap pressure valve opens 6.25 to 7.50						
Radiator hose	Type	Fabric reinforced rubber hoses, with special curved design						
	Location and size	Inlet	Elbow type, cylinder head to radiator, 1.50 ID					
		Outlet	Compound curved, coil spring reinforced, radiator to water pump, 1.75 ID					
Thermostat	Make and type		Harrison, bellows operated poppet valve					
	Location		In cylinder head water outlet					
	Valve action		At 29" mercury barometric pressure, starts to open at 157°-163°F, fully open at 183° F.					
Engine fan	Make		Chevrolet					
	Type and size		4 staggered blades, 20 diameter					
	Pulley size		36° V x 7.00 pulley diameter					
	Ratio to engine		.949:1 (Fan RPM: Engine RPM)					
	Fan Belt	Material	One-piece reinforced rubber					
		Size	.50 x 41.50 approximately pitch length		.50 x 42.313 approx pitch length			
	Shroud	¢	With RPO 256		Regular			
Water pump	Type and drive		Centrifugal, by fan belt					
	Location		On front of cylinder and case					
	Capacity (Gals/min) @ Engine RPM		55 @ 4000					
	Bearing		Anti-friction bearings, see pages 148-151					
	Seal		Molded rubber, spring loaded					

\* - Same as 3600, 3800, 4000    ¢ - Same as 3600, 3800

### FUEL SYSTEM

#### FUEL TANK

ITEM		31-3200, 3600	3800	41-4400 61-6400	34-35-3700	4502, 6702, 6802
Location	Chassis and single unit bodies	Inside of frame on right side		Outside of frame on right side		
	Cab Models *	Behind seat in cab, equipped with fuel line shut off and drain cock				
Type of construction		Two stamped pans, seam welded together				3 piece, seam welded
Capacity	Cabs	17.5				
	Others	17		18	18	30
Filler location		On right side of vehicle with vent pipe on cab and single unit bodies				
Gauge (tank)	Make	AC				
	Type	Electric				
Filter		40 mesh metal filter cloth tube mounted on end of riser pipe				

### CARBURETOR

ITEM		31-3200, 3600, 3800 4000, 6000	6000 RPO	34-35-3700
Make		Rochester		Carter
Model		7004468	7005140	BB1-871-SB
Type		Downdraft		Updraft
Idle adjustment (Number of turns open)		Single adjustment, balanced		
Size (Main venturi throat ID)		1.344	1.469	1.188
SAE flange size		1.50		
Float level when closed		Bottom of float is 1.313 below finished surface of cover		Top of float 0 to .031 below top of float chamber
Choke		Manual (No automatic choke)		
Manifold	Heat control	Automatic (thermostatic)		
	Cover	None		

### AIR CLEANER

ITEM		31-3200, 3600, 38-4000	34-35-3700	6000
Make		AC		
Silencer & flame arrester type, oil-wetted		Regular		
Heavy duty oil bath type	1 pint oil capacity	Regular		
	2 pint oil capacity	RPO 216		Regular

3-25-55. Revised: 8-1-55, \* - Data Corrected  
126 - ENGINE, SIX CYLINDER

CHEVROLET 1955 SPECIFICATIONS - TRUCK

**FUEL SYSTEM - Continued**

**OCTANE SELECTOR**  
 Type ----- Clamped on distributor shaft with 2° range manual adjustment

**FUEL PUMP**  
 Make and Model ----- AC, model AF

Type ----- Mechanical (diaphragm) "high reserve"  
 Drive ----- From camshaft  
 Arm movement ----- 1/4 at camshaft  
 Air dome ----- Yes (Inlet and Outlet)  
 Filter ----- See Fuel tank  
 Pressure at carburator ----- 3.5 to 4.5 PSI

**EXHAUST SYSTEM**

Muffler:  
 Make and type ----- Various makes; diffusion and resonance type with straight through flow

Muffler mounting ----- Single-point  
 Exhaust pipe outside diameter ----- 2  
 Tail pipe inside diameter ----- 1.313

**ENGINE LUBRICATING SYSTEM**

**METHOD OF LUBRICATION**  
 Type ---- Full pressure (direct and metered pressure)  
 Main bearings ----- Direct pressure through drilled passages in cylinder case  
 Camshaft bearings ----- Direct pressure through passages from main bearings  
 Timing gears ----- Sprayed by nozzle which is fed oil from the camshaft front bearing  
 Connecting rod bearings ----- Direct pressure from main bearings through drilled passages in crankshaft  
 Cylinder bores and piston pins ----- Sprayed from metering hole in each connecting rod bearing  
 Valve mechanism ----- Oil flows from rear camshaft bearing through drilled passage to push rod chamber through metering hole in pipe fitting, then is piped to rocker shaft and arms. Valve stems, springs, and push rods are gravity-fed from rocker arms.

Width of gears ----- 1 inch  
 Intake ----- Floto-type with 16 mesh galvanized wire screen.

**MISCELLANEOUS**

Oil level gauge ----- Rod type

Oil Filter (RPO 237)		
Make and Model	Capacity (Dry)	Replaceable element Model No.
AC S-6	1 quart	P-115
AC S-2	2 quart	P-117

**OIL PAN**

Capacity (quarts) ----- Dry, 5.5; refill, 5.0  
 Drain plug location ----- At rear of oil pan  
 Torque, corner bolts ----- 12.5 to 15 ft lb  
 Torque, flange screws ----- 6-7.5 ft lb

**OIL PUMP**

Type ----- Spur gear  
 Drive ----- From camshaft by worm gear  
 Capacity (Gallons per minute, hot oil) ----- 4.30 @ 1170-1200 engine RPM  
 Normal oil pressure (hot) ----- 35 PSI @ 1170-1240 engine RPM

**LUBRICANT RECOMMENDED**

Temperature, ambient Grade  
 Not lower than 32° F ----- SAE 20W or SAE 20  
 As low as 10° F ----- SAE 20W  
 As low as minus 10° F ----- SAE 10W  
 Below minus 10° F ----- SAE 5W

**CRANKCASE VENTILATION AND OIL FILLER**

Crankcase ventilation ----- Forward control and 261 engine models ----- Vacuum operated. Closed outlet tube from ventilator body to inlet manifold provides suction when engine is running. All others ----- Open outlet tube, extending 3-25-55.

from ventilator body into air stream beneath engine, provides suction when vehicle is moving.  
 Air Inlet (261 Engine) --- Through air cleaner to rocker cover. All others, Inlet louvers in rocker cover.  
 Oil filler location ---- On valve rocker cover at front

## ENGINE ELECTRICAL SYSTEM

### GENERATOR

Series Usage	3000	4-6000	
Make	Delco		
Model number	1100310		
Rated voltage	12-15		
Ventilation	By fan in generator pulley		
Driven by	Fan belt		
Pulley size	V angle	36°	
	Pitch dia	3.62	5.00
Speed ratio (Generator to engine)	1.83:1	1.33:1	
Max output speeds (Hot)	Gen RPM	2750 and up	
	Eng RPM	1500	2070
Bearings:	Commutator end	Drive end	
Number	812823		
Type	Bronze bushing	Anti-friction bearing	
I. D.	.562-.563		
O. D.	.778-.780		
Length	.792-.807		
Brush spring tension	24 to 32 ounces		
Rotation (drive end)	Clockwise		

### VOLTAGE AND CURRENT REGULATOR

Series Usage	3-4-6000	
Make	Delco-Remy	
Model	1118945	
Type	Vibrator	
Location	In engine compartment on left side of dash	
Voltage regulator	Volts	14.5
	Temperature	Operating
	Average air gap	.075
Current regulator	Amperage	25
	Temperature	Operating
	Average air gap	.075
Cut-out relay	Points closing (Volts)	12.8
Generator armature speed (RPM)	1300	
Average air and point gap	.020	

### STARTING

Starting Device ----- Key turns Ignition Switch 3 Positions: Locked off, On, and Start for Series 34-35-3700 and Models equipped with Automatic transmission; all other models foot operated.

Starting Operation ----- Turn ignition key to extreme right on Series 34-35-3700 and Models equipped with Automatic transmissions. For all other Models depress starter.

Pinion meshes ----- From front of flywheel

Pinion teeth (Starter) ----- 9

Flywheel teeth ----- 168

Gear Ratio (Starter to flywheel) ----- 18.67:1

### STARTING MOTOR

Make ----- Delco-Remy

Model: Series 34-35-3700 ----- 1107626

Automatic transmission ----- 1107633

All others ----- 1107634

Number of field coils ----- 4

Direction of rotation (Front view) -- Counter-clockwise

Bushing	Commutator end	Drive end
Type	Oilless, rolled bronze, with graphite-filled indentations on inside surface.	
I. D.	.5625-.5635	.4715-.4735
O. D.	.6245-.6255	.5165-.5175
Length	.812	.719

Test data: Lock test No load test

Amperage ----- 415 ----- 65

Volts ----- 5.8 ----- 10.4

Torque ----- 12 ft. lb.

RPM ----- 7900

Brush spring tension ----- 30 ounces

### BATTERY

ITEM	45-67-6800 Reg. (RPO All others except FWD Controls)	Reg. Production all Models except School Buses
Make and Model	Delco, 3SM 70-W	Delco, 2SM 50-W
SAE Number	N. A.	
Length, at top	11.97	10.19
Width, at top	6.75	
Height (Overall)	8.81	
Voltage	12	
Capacity @ 20-hour rate	70 amp hours	50 amp hours
Bench normal Charging rate	4.5	3.5
Cells	6, Side-to-side arrangement	
Plate per cell	11	9
Ground	Negative terminal	
Location	On right side of dash under hood	

### IGNITION SYSTEM

Type ----- Separate units, high tension distributor with centrifugal and vacuum spark advance, high intensity spark and water proof ignition coil.

Ignition cable: Make ----- Packard Electric

### COIL

Make, model ----- Delco-Remy, 1115085

Location ----- Engine right side

Amperes drawn-4.0 Engine stopped; 1.8 idling (500 RPM)

Resistor type ----- External

### SPARK PLUGS

Make and model:

Thriftmaster ----- AC, 44-5 Com

Loadmaster & Jobmaster ----- AC, 43-5 Com

Thread size ----- 14mm

Recommended gap ----- .033-.038

Recommended torque ----- 15-25 ft lb

### RPO HEAVY DUTY GENERATOR EQUIPMENT

Series	3-4-6000	31-32-36-3800-4-6000	3-4-6000	31-32-36-38-4000
Make	Delco-Remy			
Usage	30 amp Std steering	30 amp Power steering	40 amp Std steering	40 amp Power steering
Generator number	1102014	1102020	1106981	1106982
Regulator number	1118826		1118948	

3-25-55. Revised: 8-1-55 •-Data Revised

ENGINE ELECTRICAL SYSTEM - Continued

DISTRIBUTOR

Distributor (Delco-Remy)	1112403	1112407
Engine, cu. in. displacement	235.5	261
Breaker contact opening	.016-.021	
Nominal cam angle	26°-33°	
Breaker arm tension	19-23 oz.	
Vacuum control part number	1116089	
Condenser	Part number	1928111
	Capacity	.2 mf

VALVE TIMING (theoretical) 235.5 ENGINES

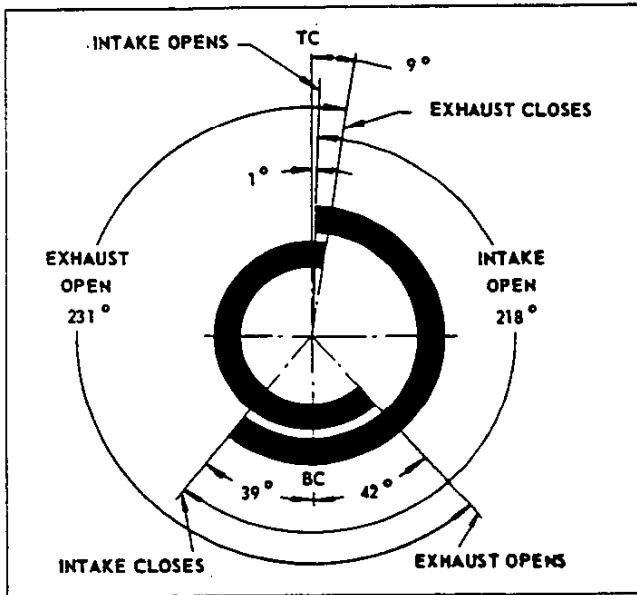

VALVE TIMING (theoretical) 261 ENGINE

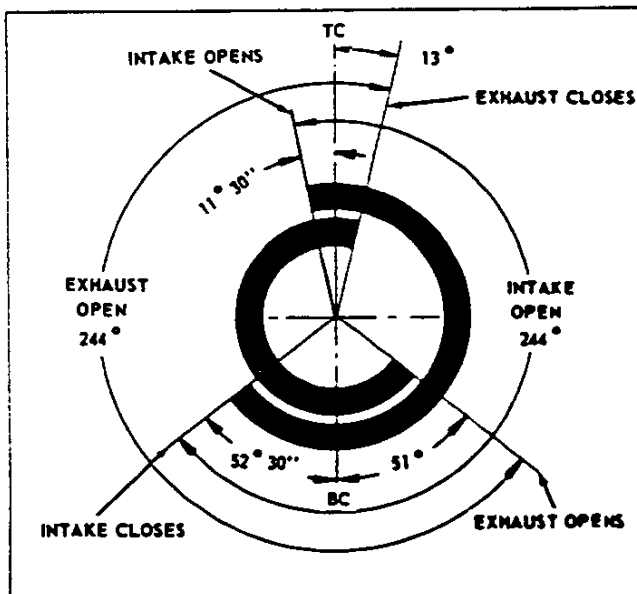

ENGINE TIMING-IGNITION

(Ignition data given in crankshaft degrees)

Timing spark advance (initial setting)	
235.5 Engine	U. D. C.
261 Engine	U. D. C.
Timing mark, location	Steel ball in flywheel
Firing order	1-5-3-6-2-4
	3-25-55

CHEVROLET 1955 SPECIFICATIONS - TRUCK

THRIFTMASTER & LOADMASTER  
235.5 CU IN. ENGINES

Automatic Spark advance	Advance begins	Full advance
Vacuum Control	4" to 6" Hg	13° to 17° @ 7.5" to 10" Hg
Centrifugal	450 to 750 RPM	24° to 28° at 3500 RPM and up

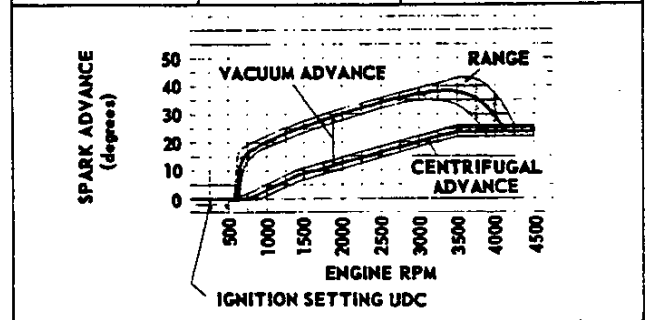

JOBMASTER 261 CU IN. ENGINE

Automatic Spark advance	Advance begins	Full advance
Vacuum Control	4" to 6" Hg	13° to 17° @ 7.5" to 10" Hg
Centrifugal	500 to 700 RPM	32° to 36° at 3600 RPM and up

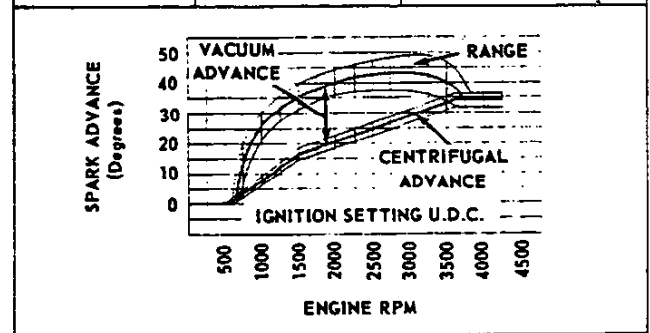

ENGINE MOUNTING

TYPE: 4-POINT RUBBER CUSHIONED

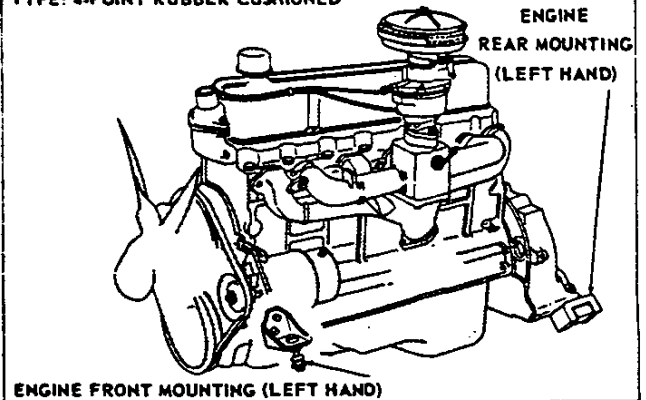

ENGINE, SIX CYLINDER - 129



**ENGINE - GENERAL**

Basic V-8 Engine Data●

	RPO 3100-3200	RPO 3600	RPO 3800	RPO 4000	Reg 5000	RPO 6000	
Piston displacement (cu. in.)	265.0						
Bore and Stroke (Nominal)	3.75 x 3.0						
Type	Valve-in-head						
Compression Ratio	7.5:1						
Taxable (SAE) horsepower	45						
Idling speed	475						
Comp. pressure (Engine hot)	160 PSI or better at cranking speed						
Dry Weight (Pounds)	Engine and Clutch	N. A.					
	With transmission	N. A.					
Governor Equipment					RPO 241		
Governor Speed (RPM)					2800- 3800		

**ADVERTISED MAXIMUM ENGINE PERFORMANCE●**

ITEM	RPO 3100, 3200, 3600, 3800, 4000, Regular 5000, RPO 6000
Horsepower	Gross 145 @ 4000 RPM
	Net 126 @ 4000 RPM
Torque (ft. lbs.)	Gross 238 @ 2000 RPM
	Net 220 @ 2000 RPM

**ENGINE SPEED AND PISTON TRAVEL #**

Series	Tire Size	Axle Ratio	Transmission Type	Engine RPM at one MPH				Piston Travel (ft/mi) 265 Engine●	Crankshaft (rev/mile)	
				Low	2nd	3rd	High			
3100 3200	6.70-15	3.9:1	3-Speed	144	82	49		1471	2941	
			4-Speed	146	175	84	49			
			3-Speed Heavy-Duty	155	86	49				
		4-Speed Automatic	187	129	71	49				
		Overdrive Locked out	152	87	52		1550			3099
		Locked in	106	61	36					
	6.50-16	3.9:1	3-Speed	138	79	47		1408	2816	
			4-Speed	131	168	80	47			
			3-Speed Heavy-Duty	142	82	47				
		4-Speed Automatic	179	123	68	47				
		Overdrive Locked out	145	83	49		1484			2967
		Locked in	102	58	35					
	15	3.9:1	3-Speed	134	77	46		1369	2738	
			4-Speed	122	163	78	46			
			3-Speed Heavy-Duty	145	86	46				
		4-Speed Automatic	174	120	66	46				
		Overdrive Locked out	141	81	48		1443			2885
		Locked in	99	57	34					
3600	15	4.57:1	3-Speed	157	90	53		1604	3208	
			4-Speed	177	191	91	53			
			3-Speed Heavy-duty	169	94	53				
			4-Speed Automatic	252	162	83	53			

3-25-55, Revised: 8-1-55, ●-Data Revised  
130 - ENGINE, EIGHT CYLINDER

CHEVROLET 1955 SPECIFICATIONS - TRUCK

ENGINE - GENERAL - Continued

Series	Tire Size	Axle Ratio	Transmission Type	Engine RPM at one MPH				Piston Travel (Ft/mi)●	Crankshaft (rev/mile)			
				Low	2nd	3rd	High					
3600	6.50-16	4.57:1	3-Speed	162	92	55		1650	3300			
			4-Speed	388	197	94	55					
			3-Speed Heavy-Duty	174	96	55						
			4-Speed Automatic	259	167	86	55					
	7.00-17		4.57:1	3-Speed	143	82	49		1460	2920		
				4-Speed	344	174	83	49				
				3-Speed Heavy-Duty	154	85	49					
				4-Speed Automatic	229	147	76	49				
	7.50-17		4.57:1	3-Speed	139	79	47		1415	2829		
				4-Speed	333	169	81	47				
				3-Speed Heavy-Duty	149	83	47					
				4-Speed Automatic	222	143	74	47				
3800●	7.00-17	5.14:1	4-Speed	386	196	94	55	1642	3284			
			3-Speed Heavy-Duty	174	96	55						
			4-Speed Automatic	258	166	85	55					
			4-Speed	374	190	91	53					
	7.50-17		5.14:1	3-Speed Heavy-Duty	168	93	53		1591	3182		
				4-Speed Automatic	250	161	83	53				
				4-Speed	374	190	91	53				
				3-Speed Heavy-Duty	168	93	53					
	7.00-18		5.14:1	4-Speed Automatic	250	161	83	53	1594	3187		
				3-Speed Heavy-Duty	168	93	53					
				4-Speed	374	190	91	53				
				4-Speed Automatic	250	161	83	53				
4000	6.50-20	6.17:1	4-Speed	437	222	106	62	1457	3714			
	7.00-20			425	215	103	60	1805	3609			
	7.50-20			410	208	99	58	1743	3486			
	6.50-20			5.83:1	413	209	100	58	1755	3510		
				7.95:1	563	286	136	80	2393	4786		
	7.00-20			5.83:1	401	203	97	57	1706	3411		
				7.95:1	547	277	132	78	2326	4651		
	7.50-20			5.83:1	388	197	94	55	1647	3294		
				7.95:1	528	268	128	75	2246	4492		
	5000 ● 6000			7.50-20	6.17:1	4-Speed	410	208	99	58	1743	3486
				8.25-20			394	200	95	56	1675	3350
				9.00-20			379	192	92	54	1608	3215
7.50-20		7.20:1	479	243			116	68	2034	4068		
		7.20:1	460	233			111	65	1955	3910		
9.00-20		7.20:1	442	224			107	62	1876	3751		
		7.20:1	388	197			94	55	1647	3294		
7.50-20		5.83:1	529	268			128	75	2246	4492		
		7.95:1	372	188			90	53	1583	3166		
8.25-20		5.83:1	508	258			123	72	2159	4317		
		7.95:1	357	181			87	51	1519	3037		
9.00-20		5.83:1	488	247			118	69	2701	4142		
	7.95:1	426	216	103	60	1808	3616					
7.50-20	8.72:1	580	294	140	82	2464	4927					
	8.72:1	409	207	99	58	1738	3475					
8.25-20	6.40:1	557	283	135	79	2368	4735					
	8.72:1	392	199	95	56	1667	3334					
9.00-20	6.40:1	534	271	129	76	2272	4543					
	8.72:1											

● - Engine RPM is determined by locating the figure for one mile per hour and multiplying by the desired miles per hour-MPH is determined by dividing the known engine RPM by the engine RPM for one mile per hour.  
 † - Also known as N/V factor.  
 3-25-55, Revised: 8-1-55, ●-Data Revised

## ENGINE - GENERAL

### Basic Engine Data -5000 Series

Piston displacement (Cu. in.)		265.0
Bore and stroke (Nominal)		3.75 x 3.00
Type		Valve-in-head
Compression ratio		7.5:1
Taxable (SAE) Horsepower		45
Idling Speed (RPM)		475
Compression pressure (Engine Hot)		160 or better @ cranking speed
Dry Weight (Pounds)	Engine and clutch	567
	Engine, clutch and transmission	631
Governor		RPO 241
Governor speed (RPM)		2800-3800

### ADVERTISED MAXIMUM ENGINE PERFORMANCE

Horsepower	Gross	145 @ 4000 RPM	Torque (ft. lb.)	Gross	238 @ 2000 RPM
	Net	126 @ 4000 RPM		Net	220 @ 2000 RPM

### ENGINE SPEED AND PISTON TRAVEL #

Series	Tire Size	Axle Ratio	Transmission Type	Engine RPM @ One MPH				Piston Travel (feet/mile)	Crankshaft (Rev/mile)
				Low	2nd	3rd	High*		
5000	7.50-20	6.17:1	4-speed	410	208	99	58	1743	3486
	8.25-20			394	200	95	56	1675	3350
	9.00-20			379	192	92	54	1608	3215
	7.50-20	7.20:1		479	243	116	68	2034	4068
	8.25-20			460	233	111	65	1955	3910
	9.00-20			442	224	107	62	1876	3751
	7.50-20	5.83:1	2-Speed	388	197	94	55	1647	3294
	8.25-20			529	268	128	75	2246	4492
	8.25-20	5.83:1		372	188	90	53	1583	3166
		7.95:1		508	258	123	72	2159	4317
	9.00-20	5.83:1		357	181	87	51	1519	3037
		7.95:1		488	247	118	69	2071	4142
	7.50-20	6.40:1		426	216	103	60	1808	3616
		8.72:1		580	294	140	82	2464	4927
	8.25-20	6.40:1		409	207	99	58	1738	3475
		8.72:1		557	283	135	79	2368	4735
	9.00-20	6.40:1		392	199	95	56	1667	3334
		8.72:1		534	271	129	76	2172	4543

# - Engine RPM is determined by locating the figure for one mile per hour and multiplying by the desired miles per hour.

MPH is determined by dividing the known engine RPM by the engine RPM for one mile per hour.

\* - Also know as N/V factor.

## ENGINE PERFORMANCE

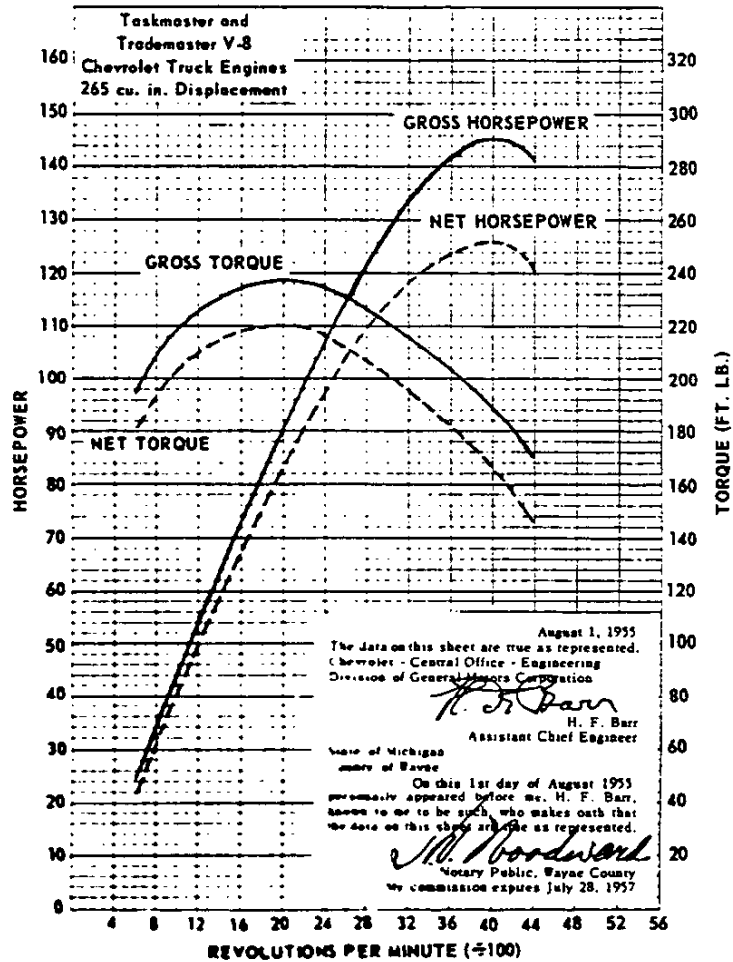

The engine performance curves shown on this sheet are taken from Chevrolet engine test report 16926-89. They represent the full throttle performance of the Taskmaster and Tridemaster 8 cylinder truck engines (265 cu. in. displacement) as obtained from dynamometer test data which were corrected to the standard barometric pressure 29.92" mercury and the standard temperature of 60°F.

regular dynamometer test with the dynamometer exhaust system, no fan, generator not charging, and optimum spark advance.

NET POWER and TORQUE were obtained from a dynamometer test simulating actual operating conditions when the engine is in its vehicle. It includes the use of the regular muffler and pipes, the fan in operation and automatic spark advance. The generator is not charging.

GROSS POWER and TORQUE were obtained in a 3-25-55. Revised: 8-1-55. • Revised to include 8-cylinder option.  
CHEVROLET 1955 SPECIFICATIONS-TRUCK

ENGINE, EIGHT CYLINDER-133

**CYLINDER AND CASE AND HEAD**

Material ----- Cast alloy iron    Offset ----- None  
 Cylinder head bolt torque ----- 60-70 ft lb    Bore diameter ----- 3.7495-3.7515

**CRANKSHAFT AND BEARINGS**

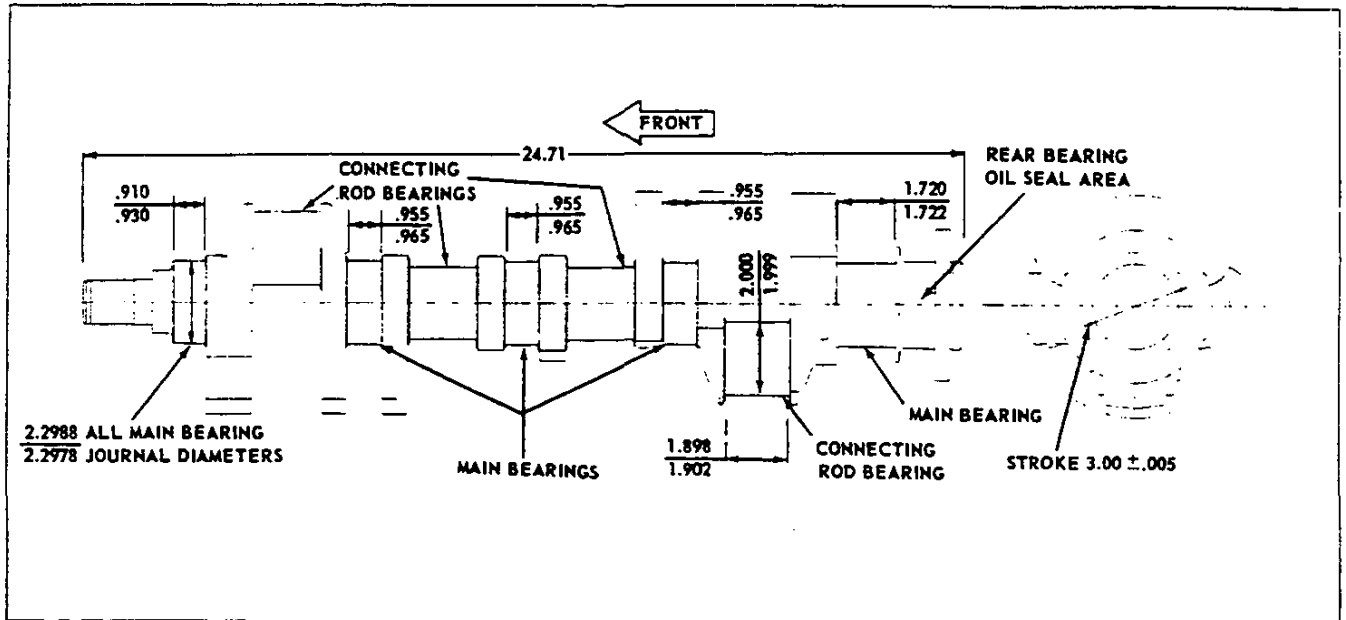

**CRANKSHAFT**

Material ----- Drop-forged steel  
 Weight ----- 47.75 lb  
 End play ----- .002-.006  
 Counter-weights ----- 6  
 Stroke ----- 3.00 ± .005

**HARMONIC BALANCER (Vibration Damper)**

Type ----- Oscillating (Rubber floated)  
 Crankshaft pulley pitch diameter ----- 6.64

**MAIN BEARING**

Type ----- Precision, interchangeable

Material ----- .003-.006 babbitt on steel shell  
 Vertical oil clearance ----- .0008-.0034  
 End thrust against ----- #5 bearing  
 Bearing cap bolt torque ----- 60-70 ft lb  
 Necessary to align ream ----- No  
 Removable ----- From below

Brg	Theo. I. D. *	Eff length †	Proj Area #
1, 2, 3, 4	2.3004	.702	1.615 ea
5	2.3004	1.160	2.667

\* - Journal diameter plus oil clearance

† - Overall length minus chamfers

# - Based on effective length and theoretical I. D.

**CAMSHAFT AND BEARINGS**

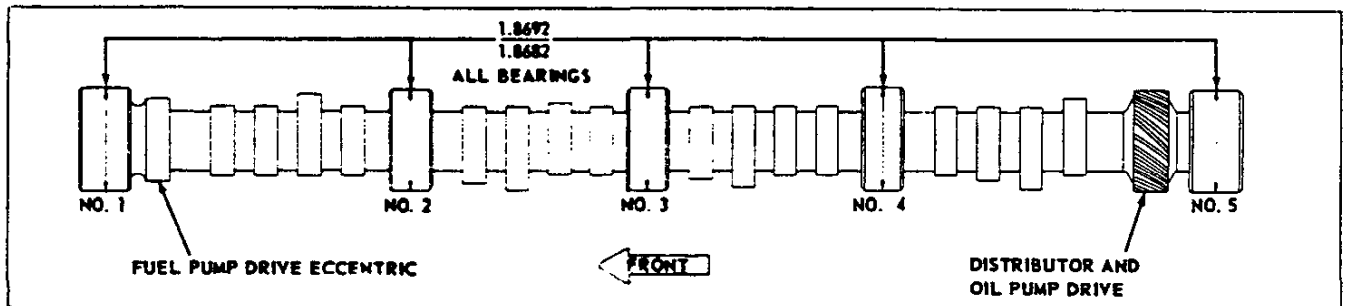

**CAMSHAFT**

Material ----- Cast alloy iron  
 Ramp:

Inlet: Opening ----- .00300, 7.5°  
 Closing ----- .00600, 24°  
 Exhaust: Opening ----- .00400, 10°  
 Closing ----- .00600, 15°

**DRIVE**

Make and type ----- Chevrolet, silent chain and sprocket, driven from crankshaft.  
 3-25-55

134 - ENGINE, EIGHT CYLINDER

Camshaft sprocket material ----- Cast alloy iron  
 Thrust ----- Rearward, carried against face of the crankcase at the front bearing.

**BEARINGS**

Material ----- Steel backed babbitt  
 Clearance on diameter ----- .0015-.0035  
 Brg      Ream dia      Overall length      Proj Area Ⓞ

1-2-3-4      1.8712      .740      1.385  
 5      1.8712      .940      1.759

Ⓞ - Based on ream diameter and overall length shown above.

CHEVROLET 1955 SPECIFICATIONS - TRUCK

PISTON - PIN - RINGS

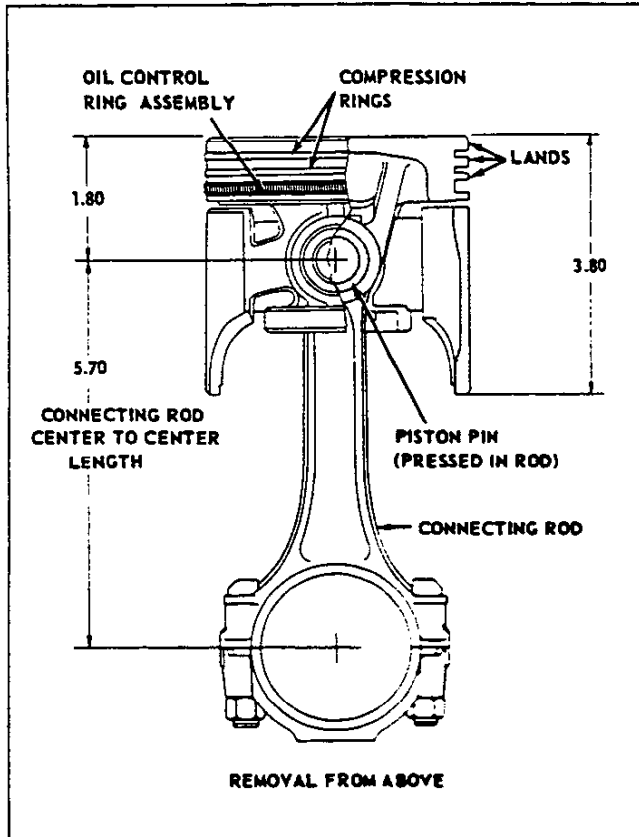

PISTON

Make .....	Chevrolet
Type .....	Slipper skirt, flat head, tin plated oval with controlled thermo expansion
Material .....	Cast alloy aluminum with steel struts
Skirt clearance in cylinder bore .....	.0005-.0011
Top land clearance in cylinder bore .....	.035-.042
Lower land clearance in cylinder bore .....	.025-.032
Compression ring groove depth .....	.2116-.2150
Oil ring groove depth .....	.2041-.2105
Holes, number and size .....	8, .156 Drill
Minimum head thickness at center .....	.25
Piston pin bushings .....	None
Weight of piston .....	1.173
Weight of piston rings, pin and connecting rod upper end X 8 (Units/Engine) .....	15.536

PISTON PIN

Material .....	Chromium steel (file hard case)
Type .....	Locked in rod (shrunk fit)
Diameter .....	.9270-.9273
Length .....	3.110-3.130
Taper limit in full length .....	.0001
Weight .....	.310
Clearance in piston .....	.00011-.00029

COMPRESSION RINGS

Type: Thick wall, twist	
Upper .....	Inside bevel, taper-faced
Lower .....	Inside bevel or counter bored
Material .....	Cast alloy iron with wear resistant coating; Chrome plate, upper ring only
Number per piston .....	2
Width .....	.077-.078
Wall thickness:	
Upper .....	.160-.179
Lower .....	.177-.187
Gap clearance:	
Upper .....	.008-.016
Lower .....	.009-.018
Ring clearance .....	.0012-.0032
Weight (each) .....	.039

OIL CONTROL RING

Material and type .....	Steel, multi-piece 2 rails and spacer
Upper and lower rails .....	Flat spring or scaleless tempered steel, full chrome plated outside diameter
Spacer (between rails) .....	Flat spring steel
Gap clearance (on rails) .....	.015-.055
Ring clearance in groove .....	.0006-.0084
Width .....	.181-.198
Maximum wall thickness (rails) .....	.168
Weight:	
Spacer .....	.023
Segment (each) .....	.025

CONNECTING RODS

Type .....	Shrink fit to piston pin
Material .....	Drop forged steel
Rod width at piston pin .....	1.007-1.011
Rod width at crankpin .....	.944-.945
Crankpin bearings:	
Type .....	Precision interchangeable insert
Material .....	Steel backed with babbitt overlay
Theoretical I.D. .....	2.0013*
Effective length .....	.8176
* - Journal diameter plus oil clearance	
‡ - Overall length minus chamfers	
# - Based on effective length and theoretical inside diameter	

Clearance on diameter .....	.0007-.0028
Projected area per rod .....	1.635#
Assembly weight (Machined) .....	1.189
Upper end weight .....	.333
Lower end weight .....	.856
Total rotating weight of connecting rods (Weight of lower end X 8) .....	6.848
End play .....	.008-.014
Recommended nut torque with oiled threads-30 to 35 ft lb	

## VALVE TRAIN

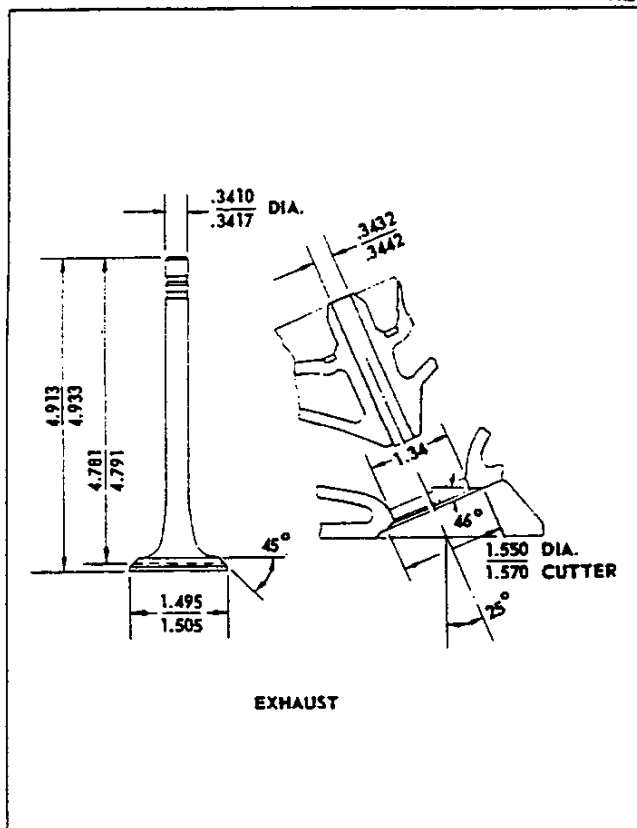

EXHAUST

### VALVES

Make ..... Own  
Material:

Exhaust valve:

All engines ..... Silchrome XCR steel

\* Trademaster--Silchrome XCR aluminum dipped seats

Inlet valve: ..... Silchrome steel

Stem end style ..... Grooved for keys & oil seal

Lift: Inlet and Exhaust valve ..... .3336

Face Angle: Inlet and Exhaust valve ..... 45°

Distance between valve centers (measured along center-line of engine) ..... 1.86

Valve lash (Engine normalized)\*

Inlet ..... Self adjusting

\* Exhaust valve rotators: (Taskmaster only) .....

..... Positive rotation type

\* - To normalize engine, run it at fast idle (approximately 600 RPM) until a constant oil temperature is maintained for a period of five minutes.

### HYDRAULIC VALVE LIFTERS

Make ..... G. M. Diesel  
Material:

Lifter body ..... Cast iron

Lifter plunger and push rod seat ..... Steel

Lift: Exhaust and inlet ..... .2224

Oil flow; Oil enters the valve lifter oil galleries through a drilled passage from the camshaft rear bearing where it flows to the hydraulic lifters. Oil enters the hydraulic lifters through holes in the side of the lifter body and plunger. Oil enters the ram chamber around the steel ball and is delivered to the disc valve which meters the oil into the hollow push rods.

3-25-55. Revised: 8-1-55, e-Data revised.

136 - ENGINE, EIGHT CYLINDER

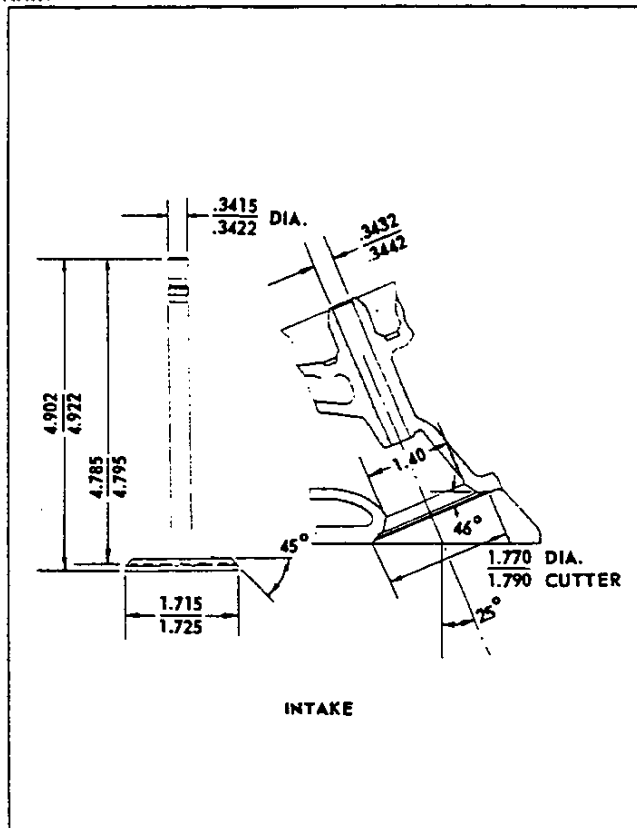

INTAKE

### VALVE STEM GUIDES

Type ..... Integral in cylinder head

Clearance with stem:

Exhaust ..... .0015-.0032

Inlet ..... .0010-.0027

### VALVE ROCKER ARMS

Type --- Hollow arm with semi-spherical pivot bearing

Material ..... Hardened pressed steel

Ratio (valve lift to cam shaft) ..... 1.5:1

Mounting ..... Bolted to individual studs

Adjusting nut ..... Tighten to zero axial movement of push rod plus three quarter of a turn

### VALVE SPRINGS

Length and pressure:

Valve closed ..... 1.696 @ 71-79 lb

Valve open ..... 1.366 @ 145-155 lb

Free length ..... 2.03 approximately

### VALVE SEATS

Material ..... Cast alloy iron (Cylinder head)

Inserts ..... None

Angle:

Exhaust seat (In head) ..... 46°

Inlet seat (In head) ..... 46°

Width in head:

Exhaust seat ..... .062-.093

Inlet seat ..... .035-.060

### PUSH RODS

Type and material ..... Hollow, welded steel tubing

Push rod seats ..... Contained in lifter cylinder

ENGINE LUBRICATION SYSTEM

GENERAL DATA

Type ----- Controlled, full pressure
Main bearings-----Direct pressure fed from main oil gallery through drilled passages in the cylinder case to the bearings
Connecting rod bearings ----- Individually fed by oil from main bearings through drilled passages in the crankshaft.
Cylinder bores and piston pins----- Cross sprayed by pressurized jets of oil from spit holes in connecting rod caps.
Camshaft bearings ----- Direct pressure fed by vertical drilled passages from main oil gallery.
Timing chain ----- Oil supplied through camshaft front bearings and centrifugally fed through slots on sprocket hub.
Hydraulic valve lifters ----- Oil equally distributed by slot at rear camshaft bearing to lifter galleries which pass through the centerline of the lifter cylinder bores.
Rocker arms ----- Individually lubricated by oil from lifter cylinders through hollow push rods. A hole in the rocker arms allows oil to enter and lubricate the pivot area. Excess oil spills over the outside lip and into the valve spring which atomizes it for distribution on the working surfaces

OIL FILTER

Make and model ----- AC, PM-11
Type ----- Full Flow
Capacity (Dry) ----- 1 Quart
Replacement Element Number ----- PF-131

METHOD OF COOLING

Cylinder cooling ----- Full stroke length water jacket around each cylinder.
Cooling System Capacity ----- (31-32-36-3800) 17 Quarts
Standard Radiator ----- (4-5000-6000) 18 Quarts
With Heater ----- (31-32-36-3800) 18 Quarts
(4-5000-6000) 19 Quarts
Heavy Duty Radiator (RPO 256) ----- 18.5 Quarts
With Heater ----- 19.5 Quarts
Pressurized cooling system ----- Yes
Radiator pressure valve cap opens ----- 6.25 to 7.50 lb

RADIATOR CORE

Make and type ----- Harrison, cellular
Model:
Standard (31-32-36-3800) ----- 3133343
(4000-6000) ----- 3134559
(5000) ----- 3133344
Heavy duty radiator (RPO 256)
(31-32-36-3800) ----- 3133708
(4000-6000) ----- 3133708
(5000) ----- 3133345
Material ----- Copper
Cell constant and Core thickness:
Standard (31-32-36-3800) ----- .25 x .560; x 2
(4000-5000-6000) ----- .22 x .560; x 2
Heavy Duty Radiator (RPO 256)
(31-32-36-3800) ----- 20 x .560 x 2.5
4000-5000-6000)
Frontal Areas:
Standard (31-32-36-3800) ----- 426 sq. in.
(4000-5000-6000) ----- 470 sq. in.
Heavy Duty Radiator (RPO 256)
(31-32-36-3800-4000-5000-6000) ----- 470 sq. in.
3-25-55. Revised: 6-25-55. 8-1-55 e-Data Revised.
CHEVROLET 1955 SPECIFICATIONS - TRUCK

OIL PUMP

Type and drive ----- Gear, from camshaft
Location ----- At rear main bearing cap
Cleaner type ----- "Floto-type" with 16 mesh galvanized wire cloth
Relief valve ----- In pump cover
Width of gears ----- 1.198-1.200
Capacity (Gallons per minute, hot oil) ----- 4.01-4.22 @ 1170-1200 Engine RPM
Normal oil pressure (Hot) ----- 30 PSI @ 1170-1200 Engine RPM
OIL PAN

Type ----- Rear sump with welded in baffle
Capacity:
Trademaster ----- 4.5 quarts dry; 4 quarts refill
Taskmaster ----- 5.5 quarts dry; 5 quarts refill
Drain ----- Plug in rear of pan
Torque, Corner Bolts ----- 12.5 to 15 ft. lb
Torque, Flange Screws ----- 6 to 7.5 ft. lb.

MISCELLANEOUS

Oil filler ----- Tube and breather cap attached to front end of intake manifold.
Oil level gauge ----- Rod type
Oil pressure gauge ----- Instrument cluster
Crankcase ventilation (type):
Trademaster ----- Open, Road draft
Taskmaster ----- Positive, closed

LUBRICATION RECOMMENDED

Temperature: ----- Grade
Not lower than 32° F ----- SAE 20 W or SAE 20
As low as 10° F ----- SAE 20 W
As low as minus 10° F ----- SAE 10 W
Below minus 10° F ----- SAE 5 W

ENGINE COOLING SYSTEM

WATER PUMP

Type and Drive ----- Centrifugal, driven by fan belt
Location ----- At front of cylinder and case
Distribution arms ----- One per bank
Capacity ----- 44.5 Gals/min @ 4000 engine RPM
Impeller type ----- Vane
Bearings, anti-friction ----- See pages 150-153
Seal Assembly ----- Spring-loaded brass encased synthetic rubber and plastic.

ENGINE FAN AND BELT

Make and type ----- Own, 4 staggered blades
Diameter ----- 20
Pulley size:
Trademaster engine ----- 6.64 pitch diameter, 36° V
Taskmaster engine ----- 7.00 pitch diameter, 36° V
Fan to engine speed ratio:
Trademaster engine ----- .916:1
Taskmaster engine ----- .949:1
Fan Belt:
Material ----- One piece reinforced moulded rubber with wrapped or cut sides.
Size:
Trademaster engine ----- .50 x 55.33 approximate pitch length
Taskmaster engine ----- .50 x 56.86 approximate pitch length
Angle of V ----- 37°-44°
Fan Shroud:
Trademaster ----- 4000 only
Taskmaster ----- 5000-6000



## ENGINE COOLING SYSTEM

### WATER THERMOSTAT

Make and Type -----  
 ----- Harrison, bellows operated poppet valve  
 Thermostat housing - At front center of intake manifold  
 Valve action ----- @ 29" mercury barometric pressure  
 Starts to open ----- 157° to 163° F  
 Fully open ----- 83° F

### RADIATOR HOSE

Function	Inlet	Outlet
Location	Cylinder head to Radiator	Radiator to Water Pump
Quantity		
Type	Moulded Elbow	Compound Curve
Inside diameter	1.50	1.75
Material	Fabric reinforced rubber	
Spring reinforced	None	Brass Coil Spring

### FUEL TANK

Type----- 2 stamped pans, seam welded together  
 Location ----- Back of seat in cab  
 Capacity ----- 17.5 gallons  
 Filler location ----- Right side of cab  
 Fuel gauge (Tank Unit):  
 Make and type ----- AC,  
 Electric riser pipe and filter integral with unit.  
 Filter ----- 40 mesh metal  
 filter cloth tube mounted on end of riser pipe.

### FUEL SYSTEM

Air dome ----- Yes (Inlet and Outlet)  
 Pressure at carburetor----- 4 to 5.50 PSI  
 Filter ----- None (See fuel tank)

### AIR CLEANER AND SILENCER

Make and Type ----- AC, oil bath  
 Flame arrester ----- Yes  
 Filter element ----- Cactus fiber  
 Capacity:  
 Trademaster ----- 1-pint  
 Taskmaster ----- 1-quart  
 Used with governor ----- No

### EXHAUST SYSTEM

Muffler:  
 Make ----- Various  
 Type ----- Diffusion and resonance, reverse flow  
 Size (body outside) ----- 5.06 x 21.50  
 Cross under pipe ----- Flanged for attachment to exhaust manifold; Approximately 1.75 O.D.  
 Exhaust pipe ----- 2 O.D.  
 Tail pipe ----- 1.813 I.D.  
 Mounting ----- Single point

### CARBURETOR

Make ----- Rochester  
 Model ----- 7006770  
 Type -- Individually adjusted double barrel, downdraft  
 SAE flange size ----- 1.25  
 Size:  
 Venturi: throat I.D. ----- 1.16  
 Throttle body I.D. ----- 1.44  
 Choke ----- Manual

### FUEL PUMP

Make and Model ----- AC, model EN  
 Type ----- Mechanical (diaphragm) "high reserve"  
 Drive ----- From camshaft through pump push rod to rocker arm.  
 Arm movement ----- .34 @ camshaft

### EXHAUST MANIFOLD

Manifold heat control ----- Automatic (Thermostatic)

### ENGINE ELECTRICAL SYSTEM

#### SPARK ADVANCE CURVE

Automatic Spark advance	Advance begins	Full advance
Vacuum Control	5" to 7" Hg	25.5° to 29.5° at 13.5" to 16.25" Hg
Centrifugal	450 to 800 RPM	30° to 34° at 3600 RPM and up

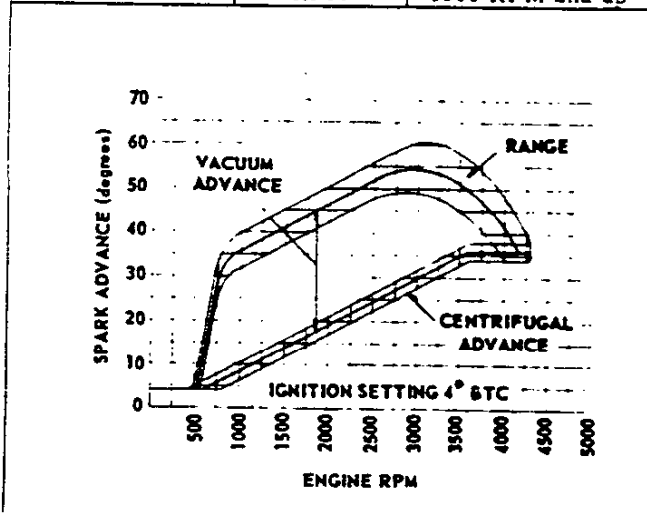

### GENERATOR

Make and model ----- Delco-Remy 1100310  
 Type ----- Two brush, shunt wound  
 Rating:  
 Amperes ----- 25  
 Volts ----- 12-15  
 Ventilation ----- By pulley fan  
 Drive ----- By fan belt  
 Pulley size:  
 31-32-36-38-4000 ----- 5.00 P.D. x 36° V  
 5000-6000 ----- 4.58 P.D. x 36° V  
 Armature shaft bearings:  
 Commuter end ----- Plain bushings  
 Drive end- Anti-friction bearing. See pages 150- 153  
 Bush spring tension ----- 24-32 ounces  
 Rotation (Drive end) ----- Clockwise  
 Generator RPM/MPH ----- 77 approximately  
 Generator RPM ----- 2750 and up  
 Speed ratio (Generator to engine):  
 31-32-36-38-4000 ----- 1.33:1  
 5000-6000 ----- 1.45:1

### DISTRIBUTOR

Make and model ----- Delco-Remy, 1110847  
 Current Source ----- Generator or battery  
 New breaker contact opening ----- .016-.021  
 Cam angle at .016 setting ----- 26°- 33°  
 Breaker arm tension ----- 19-23 ounces  
 Vacuum Control ----- Integral with distributor

## ENGINE ELECTRICAL SYSTEM

### RPO GENERATORS •

Make	Delco-Remy			
	30 amp W/O Use	30 amp with Pwr Strg	40 amp W/O Pwr Strg	40 amp with Pwr Strg
Generator Number	1102014	1102020	1106981	1106982
Regulator Number	1118826		1118948	

### VALVE TIMING (Theoretical)

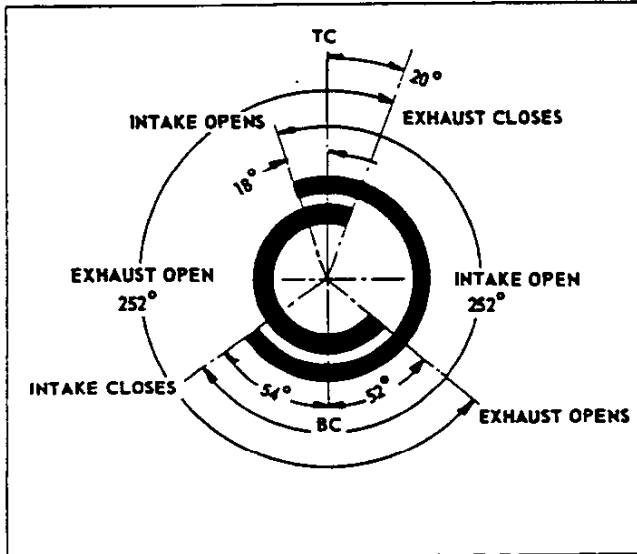

### VOLTAGE AND CURRENT REGULATORS

Make and model ----- Delco-Remy 1118945  
 Location ----- Engine compartment, left side of dash  
 Type ----- Vibrator  
 Voltage regulators  
 Volts ----- 14.5  
 Temperature ----- Operating  
 Average air gap ----- .075  
 Current Regulator  
 Amperes ----- 25  
 Temperature ----- Operating  
 Average air gap ----- .075  
 Cutout relay:  
 Points closing, volts ----- 12.8  
 Generator armature speed (Hot) ----- 1300 RPM  
 Average air and point gap ----- .020

### BATTERY •

ITEM	Reg. Production School bus, RPO all others	Reg. Production all models except School buses
	Make and model	Delco, 3SM 70-W
SAE Number	N.A.	N.A.
Length, at top	11.97	10.19
Width, at top	6.75	
Height (Overall)	8.81	
Voltage	12	
Capacity @ 20-hour rate	70 amp hours	50 amp hours
Bench normal Charging rate	4.5	3.5
Cells	6, side-to-side arrangement	
Plates per cell	11	9
Ground	Negative terminal	
Location	On right side of dash under hood	

3-25-55. Revised: 8-1-55. •-Data Revised  
**CHEVROLET 1955 SPECIFICATIONS - TRUCK**

### SPARK PLUG

Make and model ----- AC, 43-5  
 Thread size ----- 14 MM  
 Recommended gap ----- .033-.038  
 Recommended torque ----- 20-25 ft. lb.

### COIL

Make and model ----- Delco-Remy, 1115083  
 Resistor type ----- External  
 Location ----- at rear of intake manifold

### STARTING MOTOR

Make and model ----- Delco-Remy, 1107627  
 Number of field coils ----- 4  
 Rotation (Drive end view) ----- Clockwise  
 Maximum Horsepower ----- 1.23 @ 4600 RPM  
 (Equivalent to engine cranking speed of 247 RPM)  
 Brush spring tension ----- 30 ounces  
 Armature shaft bushing:  
 Drive & commutator end - Graphite lubricated bronze  
 Testing Lock Test No Load Test  
 Amperage draw --- 415 ----- 65  
 Volts ----- 5.8 ----- 10.4  
 Torque ----- 12 ft lb  
 Free speed ----- 8900 RPM

### STARTING

Motor Control:  
 Ignition switch; 3 positions; locked off, on, & start  
 Starting operation ----- Turn ignition to extreme right  
 Pinion meshes ----- From front of flywheel  
 Number of teeth ----- 9 starter pinion; 168 flywheel  
 Gear ratio (Starter to flywheel) ----- 18.67:1

### IGNITION SYSTEM

Type ----- Separate units, high tension distributor with centrifugal and vacuum spark advance; high tension spark and water proof ignition coil.  
 Ignition cable make ----- Packard Electric

### ENGINE TIMING - IGNITION

(Ignition data given in crankshaft degrees)

Timing spark advance (Initial setting) ----- 4° BTC  
 Timing mark location ----- On damper  
 Firing order ----- 1-8-4-3-6-5-7-2

### ENGINE MOUNTING

TYPE: 4-POINT RUBBER CUSHIONED

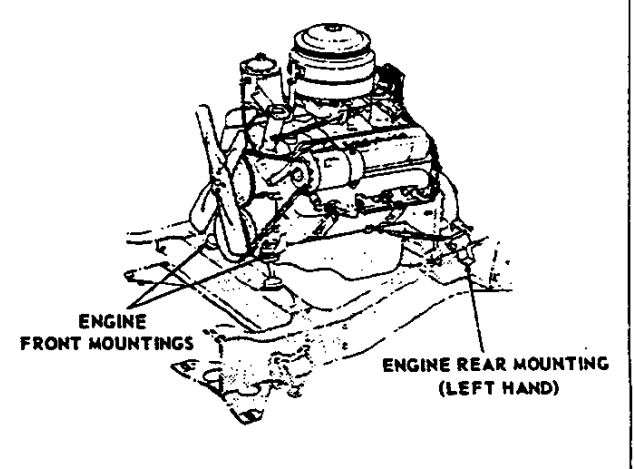

**ENGINE, EIGHT CYLINDER - 139**

CLUTCH

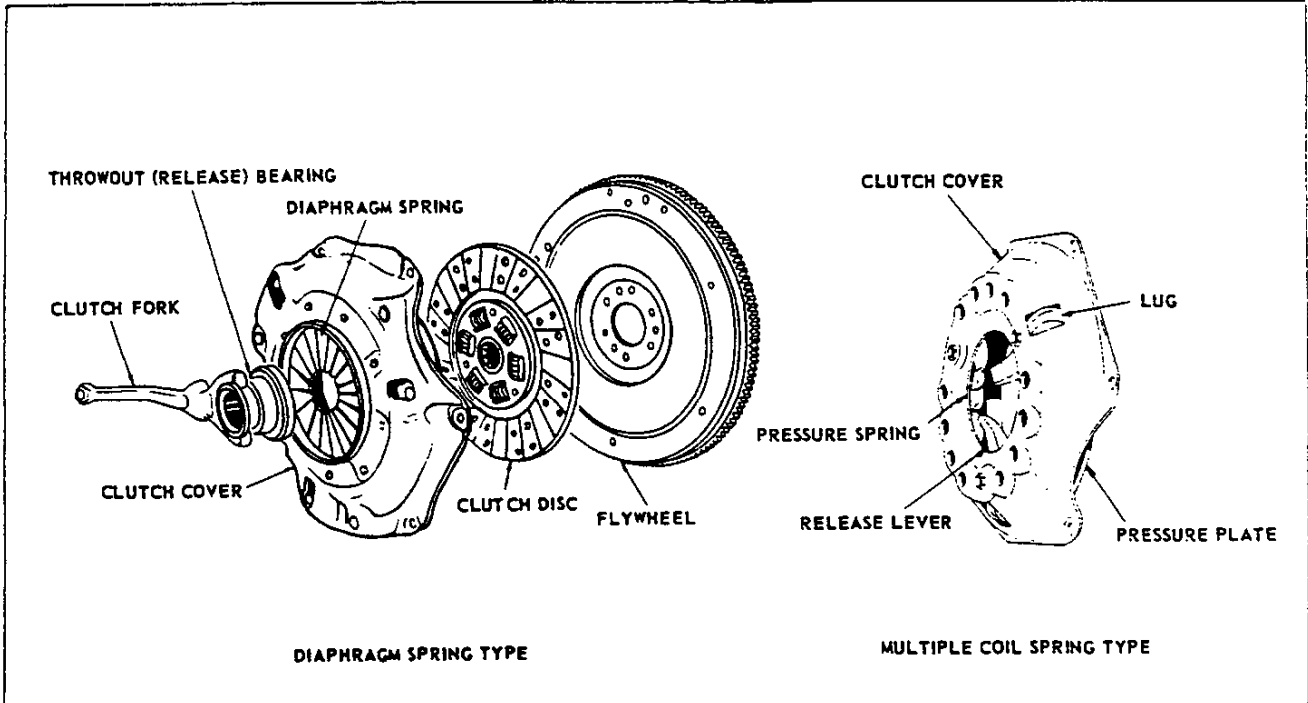

ITEM	Six-Cylinder			Eight Cylinder		
	3100-3200 3600-3800	34-35-3700 4000-6000	RPO 227 on 31-32-36-3800	31-32-3600 3800-4000	5000 6000	
Type	Diaphragm spring, single plate, Dry Disc Type			Multiple coil spring, Single plate, Dry Disc Type		
Rated torque capacity	238 ft lbs	282 ft lbs		295 ft lbs	305 ft lbs	
Drive	Strap Drive			Lug Drive		
Ventilation	Vanes Cast in pressure plate			Embossed mounting flange and holes in cover		
Clutch Springs	Material	Spring steel, heat treated			Spring wire, heat treated	
	Spring pressure	15 levers, integral with spring			12 thrust springs	
	Total clutch spring pressure	1325 to 1450 lbs	1450 to 1550 lbs		1825 lbs	
	Clutch spring release	Diaphragm action, spring pivots on pivot ring			3 levers pivoting on struts	
Driven disc	Type	One, spring cushioned plate with two facings				
	Vibration insulation at hub	6 cushion springs				
	Facing (2)	Material	Woven type asbestos composition			
		O. D.	10	11	10.5	11
		I. D.	6.5			
		Area (both facings)	100.53 sq. in.	123.70 sq in		106.81 sq in
	Thickness	.130-.136				
Bearings	Throwout (release)	Type, make & no.	Anti-friction bearings, See pages 150-153			
		Lubrication	Packed for life			
	Pilot	Make & no.	Chevrolet 412562			
		Type	Sintered powdered bronze bushing, Oil impregnated			
		I. D.	.5915-.5925			
		O. D.	1.0935-1.0945			
		Width	.740-.760			
		Lubrication	Self			
Controls	Clutch fork type	Drop-forged (pivot mounted on ball)				
	Pedal mounting location	L. C. F. models, on body mounting bracket; All others, on side rail				
Flywheel	Material	Cast alloy iron				
	Weight (with ring gear)	6 Cylinder, 31 lb; 8 Cylinder, 29 lb				
	Ring gear	Type	Cold drawn steel, shrunk on			
		Number at teeth	168 (9 teeth on starter pinion)			
	Width & pitch diameter	.480-.490 wide; 14.00 pitch diameter				
Clutch attachment to flywheel		6 bolts				

3-25-55. Revised: 8-1-55. • - Data revised. • - Molded type asbestos composition

TRANSMISSION

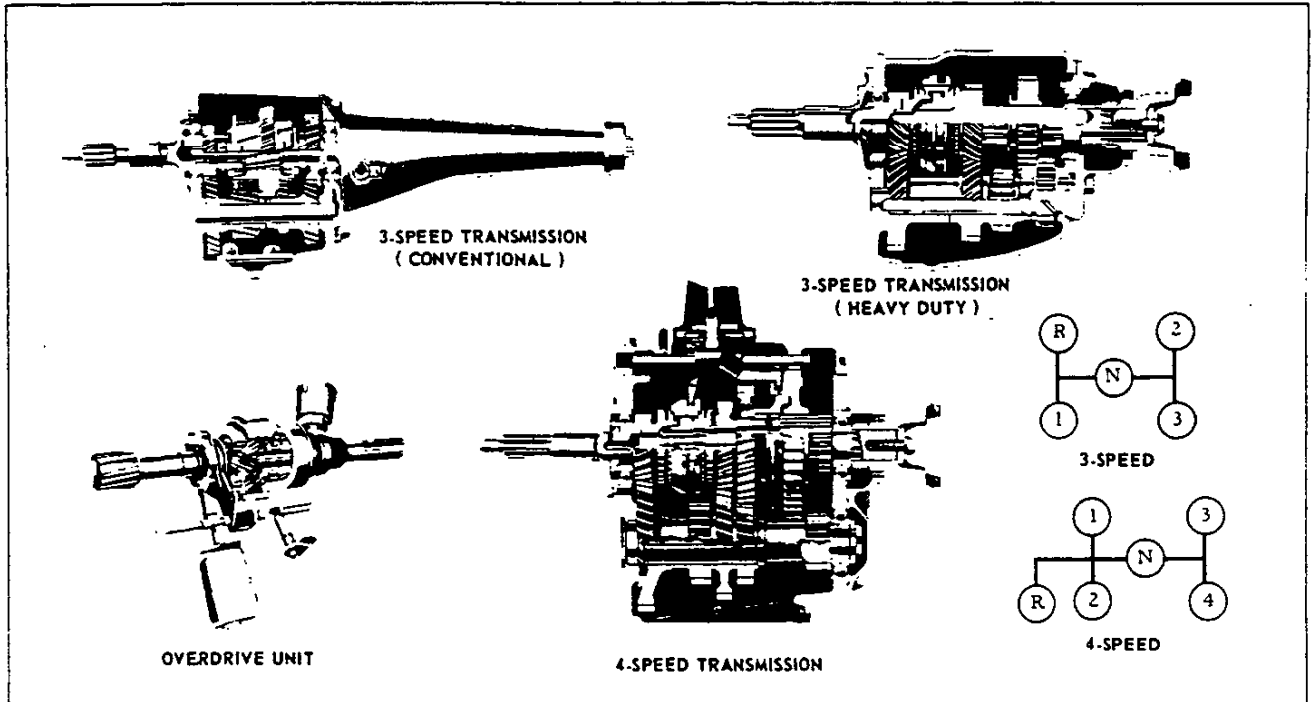

ITEM	3100-3200 3400-3500 3600-3700	RPO 3100-3200	RPO 3100-3200-3400 3500-3600-3700-3800	Reg 3800-4-5-6000 RPO 3100-3200-3400 3500-3600-3700				
Make and type	Own. 3-Spd Synchro- mesh	3 Spd. Trans. with Borg-Warner Plane- tary O.D. unit *	Borg-Warner Synchro-mesh 3-Speed H.D.	Own. 4-Speed Synchro-mesh				
Gear shift control	Type	Manual, remote						
	Location	Mounted on steering column						
Input torque capacity (ft lbs)	220		230	220				
Gears	Type	All helical		All helical except 1st & reverse				
	Material	Forged steel, hardened						
	Synchronized speeds	2nd and 3rd		2nd, 3rd and 4th				
	Constant mesh speeds	2nd		2nd and 3rd				
	Sliding gears	1st and reverse						
	Ratios	Forward	1st	2.94:1	2.94:1	2.06:1*	3.17:1	7.06:1
			2nd	1.68:1	1.68:1	1.18:1*	1.75:1	3.58:1
			3rd	Direct	Direct	0.70:1*	Direct	1.71:1
4th							Direct	
Reverse		2.94:1	2.94:1		3.76:1	6.78:1		
Over-drive unit	Cut-in	Approx. 31 mph						
	Cut-out	Approx. 27 mph						
	Manual lockout control location	Bottom LH side of instrument panel						
	Downshift accelerator control	Kickdown switch actuated by depressing accelerator pedal to full throttle						
Bushing material	Reverse idler	Bronze, ball indented						
	Trans. rear brg support							
	2nd gear				Gear ID anti-friction coated	Bronze, ball indented		
	3rd gear					Nickel phosphor bronze		
Lubricant capacity	2 pints	3 pints	2.75 pints	6.25 pints				
Power take-off provision	Type of opening							
	Location	Left side of trans.						
	Drive gear	Type	Helical					
		No. of teeth	33 teeth					
Speed	425 RPM @ 1000 engine RPM							
Anti-friction bearings	See pages 150-152							

\* - With Overdrive Unit locked-in    § - With Overdrive Unit locked out  
 3-25-55. Revised: 8-1-55.    •-Data Revised  
 CHEVROLET 1955 SPECIFICATIONS - TRUCK

## TRUCK AUTOMATIC TRANSMISSION

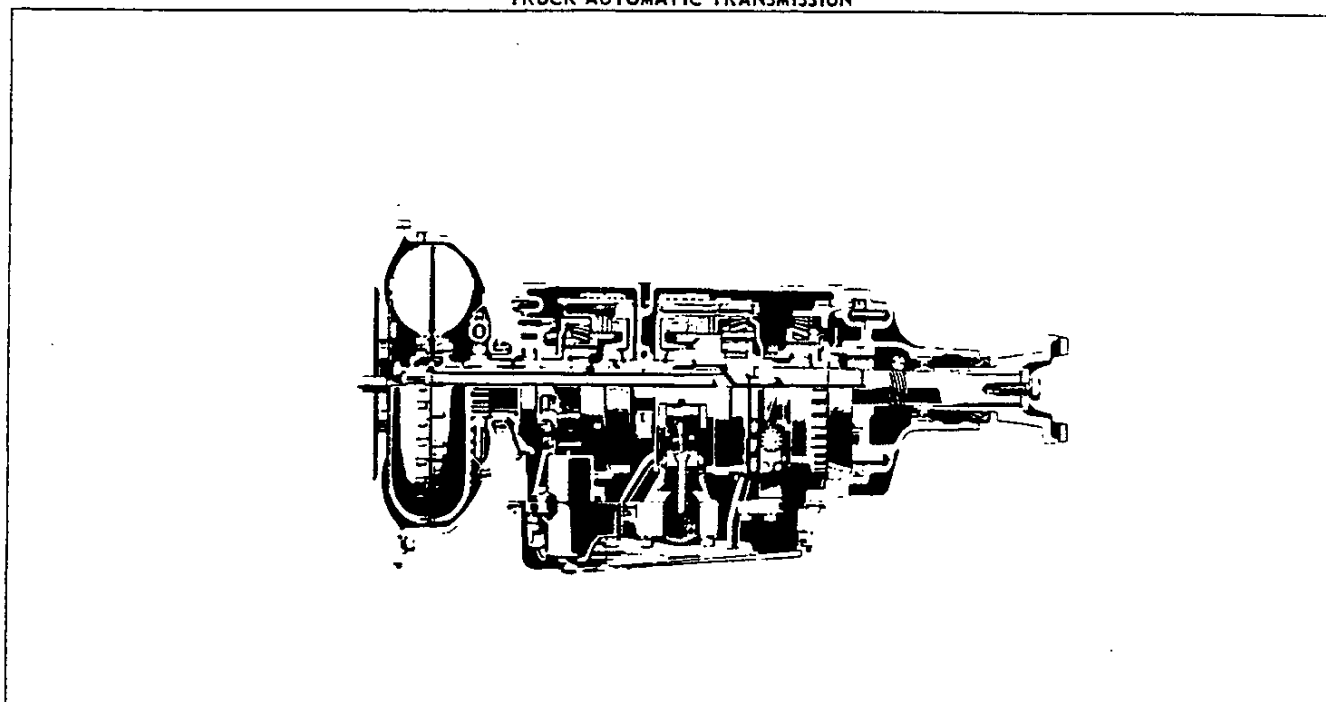

### AUTOMATIC TRANSMISSION - GENERAL

Make ----- Detroit Transmission (Hydra-Matic)  
 Identification ----- Plate on left rear face of case  
     Orange background plate ----- Series 31-3200  
     Black background plate ----- Series 34-35-36-37-3800  
 Serial numbers ----- CH 55 fol-  
     lowed by the manufacturers system of identification  
 Vehicle Weights:  
     When replacing 3-Speed transmission -----  
     ----- Add approximately 122 pounds  
     When replacing 4-Speed transmission -----  
     ----- Add approximately 60 pounds  
 Steering column selector lever ----- All  
 Selector lever positions ----- Five (left - right,  
     Neutral, 1 - 4 (four - speed range), 1 - 2 (three-  
     speed range), 1 - 2 (two-speed range), R (reverse)  
 Oil type ----- Automatic Transmission Fluid - Type A  
 Oil capacity ----- Without oil cooler, 9 qts. 8-1/2 refill  
     With oil cooler, 12 qts. 9-1/2 refill  
 Oil level gauge and filler tube -----  
     ----- On right side of transmission  
 Parking lock:  
     Type ----- Pawl and gear on  
     reverse ring gear and band on reverse sun gear  
     Operation ----- Applied  
     by selector lever in reverse with release  
 Automatic shifts ----- Throttle  
     valve and governor oil pressures position speed  
     shift valves to control the hydraulic actuation of  
     clutches and bands.

### FLUID COUPLING

Driving member ----- Sheet  
     metal multivane, half torus, driven at or below  
     engine speed through front planetary unit  
 Driven member ----- Sheet  
     metal multivane, half torus, splined to mainshaft  
     and driven by fluid reaction from driving member  
 Flywheel ----- Heavy pressed  
     steel with teeth cut in outer edge and hardened  
 3-25-55 Revised: 8-1-55 • Data Corrected  
 142 - AUTOMATIC TRANSMISSION

### PLANETARY GEAR UNITS

Gear ratios:	31-3200	Series	34-35-36-37-3800
First -----	3.82:1	-----	4.71:1
Second -----	2.63:1	-----	3.03:1
Third -----	1.45:1	-----	1.56:1
Fourth (Direct) -----	1:1	-----	1:1
Reverse -----	4.30:1	-----	6.11:1
Planetary gear ratios:			
Front planetary unit:			
1st, 3rd, Reverse -----	1.45:1	-----	1.56:1
2nd, 4th -----	1:1	-----	1:1
Rear planetary unit:			
1st, 2nd -----	2.63:1	-----	3.03:1
3rd, 4th -----	1:1	-----	1:1
Rev. (with reverse unit) -----	2.97:1	-----	3.93:1
Multiple disc clutches:			
Front unit			
Driving plates -----	4	with bonded facings	
Driven plates -----	4	steel	
Piston material -----	Die cast Aluminum		
Rear unit			
Driving plates -----	7	-----	8
-----	with bonded facings		
Driven plates -----	7	-----	8
Piston material -----	Die cast Aluminum		
Reverse clutch			
Type -----	Cone		
Piston material -----	Die cast Aluminum		
Oil Cooler -----	Series 34-35-37-3800		
Type -----	Plate		
Location -----	In transmission oil pan sump		
Water circulation -----	From discharge side of water pump to transmission oil pan and return to rear of cylinder block.		

### CARBURETOR

ITEM	31-32-36-3800	34-35-3700
Make	Rochester Product	Carter
Model No.	7007181	3705500 •
Choke	Automatic	

### STEERING GEAR

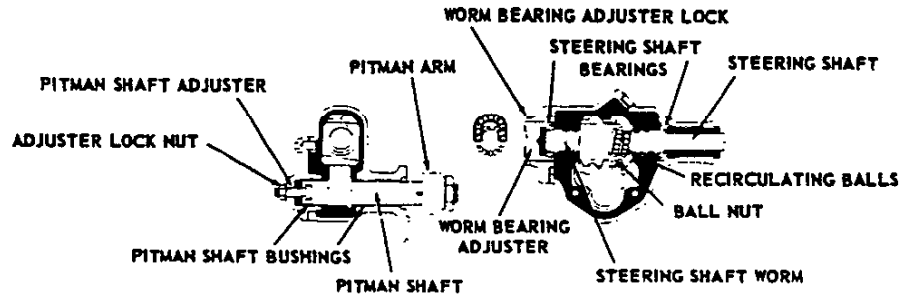

ITEM		31-32-35-3800	34-35-3700;5000	4000-6000	
Make and type		Saginaw steering gear; Semi-reversible recirculating ball			
Ratio		21.3:1	27.76:1	23.6:1	
Mounting		On frame side member			
Pitman Shaft bushings	Material	Cast bronze			
		Outer	Inside dia	1.1245-1.1250	1.2495-1.2500
	Inner	Length	1.375	1.125	1.50
		Inside dia	1.1255-1.260		
Pitman shaft	Diameter	Outer end	1.1205-1.1215	1.245-1.246	
		Inner end	1.123-1.124		
	Location	Straddle mounted in steering gear housing assembly			
Worm and Steering shaft	Type	Worm integrally welded to shaft			
	Shaft diameter	.750	.813		
Pitman arm type		One-piece; drop forged steel			
Steering column outside diameter		1.75			
Gear adjustment (lash)		Adjusting screw & nut; 2 to 3-1/2 lb pull at rim of steering wheel			
Horn cable and contact		Cable lead attached to rubber imbedded contact ring at inside upper end of column			
Steering Wheel	Type and material	3-Spoke; Hard rubber vulcanized to steel insert			
	Diameter	18			
Anti-friction bearings		See pages 148-151			

### POWER STEERING

ITEM		31-32-36-3800	4-5-6000
Type		Linkage with open center valve	
Steering cylinder I. D.		1.37	2
Pump	Type	Vane, hydraulic	
	Mounting	On rear of generator	
	Driven by	Splined extension of generator shaft	
	Max. flow rate	1 to 1.3 G. P. M.	1.7 to 3 G. P. M.
Steering assistance provided		Up to 80%	

### TURNING DIAMETERS @

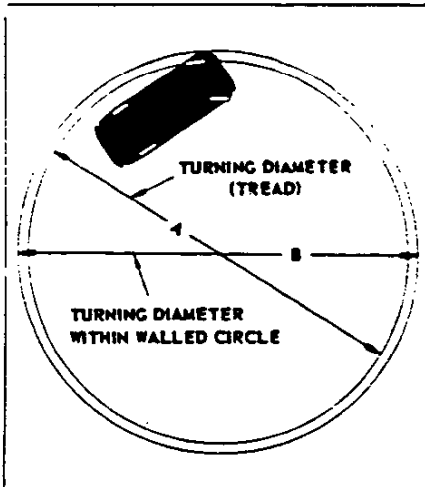

Series	Wheelbase	A (feet) *		B (feet) *	
		Right	Left	Right	Left
3100	114	38.00	39.00	40.75	41.75
3200	123.25	40.00	41.50	42.75	44.25
3400	104	45.50	37.00	#	#
3500	125	53.00	43.00	#	#
3600	123.25	40.50	42.50	43.25	45.25
3700	137	57.00	46.50	#	#
3800	135	44.50	47.50	47.25	50.25
4100	130	43.00	43.00	46.50	46.50
4400	154	49.00	49.00	52.50	52.50
4500		53.50	53.50	57.00	57.00
5100	112.625	50.50	42.50	54.00	46.00
5400	136.625	59.50	50.00	63.00	53.50
5700	160.625	68.00	56.50	71.50	60.00
6100	130	46.50	46.50	50.00	50.00
6400	154	53.50	53.50	57.00	57.00
6500	172	58.50	58.50	62.00	62.00
6700	194	65.00	65.00	68.50	68.50
6800	220	72.50	72.50	76.00	76.00

\* - Theoretical Dimensions. @ - All dimensions based on vehicles with standard equipment.

# - Variable, dependent on style of body.

3-25-55

CHEVROLET 1955 SPECIFICATIONS - TRUCK

STEERING - 143

**TIRES - TUBES - WHEELS**

Tire Size and Ply Rating	Base or RPO #	Models	Number of Tires	Tire and Rim Association Standards						Wheels§			
				Loaded		Maximum Recommended		Tube Section	Valve @	Flap	Rim Size	Offset	Attachment
				Rolling Radius	Rev Per Mile	Capacity	Press. PSI						
6.70-15-4†	Base	3100 3200	Five #	13.4	754	925	24				15 x 5K	9/16	Six 7/16-20 bolts, 5-1/2 circle
6.70-15-6‡	288					1055	30						
6.50-16-6‡	282			1215	36								
15-6	273			14.4	702	1605	45	7.00	150 SB90°	15L	15x 5.50 F	O	
7.00-17-6	Base	3400 3500 3700	Four	15.7	637	1730	45	7.00W	76	17M	17 x 5.0	7/16	Eight: 1/2-20 bolts, 6-1/2 circle
7.00-17-8	278					2060	60						
7.50-17-8	272			2440	65	7.50W							
7.00-18-8	295		Six	16.2	620	2140	60	7.00W	76SB	18M	18 x 5.0	4-9/16	
15-6	Base	3600	Four	14.4	702	1605	45	7.00	150 SB90°	15L	15 x 5.50 F	1/8	
15-8	280					1900	60						
7.00-17-6	277			1730	45	7.00W	76	17M	17 x 5.0	7/16			
7.00-17-8	278					2060	60						
7.50-17-8	272			16.3	619	2440	65	7.50W					
6.50-16-6‡	282	3602-03 08-09-12	Six	13.9	722	1215	36	6.50	150 SB90°	16L	16 x 5.50 F	4-9/16	
7.00-17-6	Base †	3800	Four	15.7	637	1730	45	7.00W	76	17M	17 x 5.0	7/16	
7.00-17-8	278					2060	60						
7.50-17-8	272			2440	65	7.50W							
7.00-18-8	295	3802-03 08-09-12		16.2	620	2140	60	7.00W	76SB	18M	18 x 5.0	4-9/16	
6.50-20-6	Base	4000	Six	16.7	602	1870	50	6.50W	76-90° E-12	20K	20 x 5.0 #	4-3/4	Five front and Ten rear 5/8-18 bolts, 7-1/4 circle
7.00-20-8	300					2310	60						
7.00-20-10	296			2580	75	7.00W	76 SB90°						
7.50-20-8	304			17.8	565	2740	65	7.50W	177 SB90°	20M	20 x 6.0	5-3/8	
7.50-20-10	305	2740	80										
7.50-20-8	Base	5000 (S)	2740	65									
7.50-20-10	305	6100 (S)	2970	80									
8.25-20-10	343	6400 (S)	3330	70	18.5	543	3600	80	8.25W	77-90° C-20	20 x 6.5 Ⓞ	5-5/8	
8.25-20-12	344	6500 (S)											
9.00-20-10	312	6700 6800		19.3	521	3960	70	9.00W	175-90° C-20	20N			

\* - Base equipment includes tires of the same size and ply rating on front and rear wheels. Except for 9.00-20-10 pr tires, which are available for rear only, all tires shown for each series are available in any front and rear combination provided tires of a larger size or ply rating are not used on the front, and provided front, rear and spare wheels remain interchangeable.

† - Passenger car type tires. All others shown are truck type. ‡ - Tubeless tires. # - Includes spare.

Ⓞ - Tire and Rim Association numbers.

§ - All models, except 3400-3500-3700, are furnished with a spare wheel as standard equipment.

¶ - Base tires for 3800 series are 7.00-17-6 pr front and 7.00-17-8 pr rear.

# - 20 x 6.0 rims used with 7.00-20 tires when 7.50-20 rear tires are used.

Ⓞ - 20 x 6.5 rims are available as RPO 291, mandatory with 9.00-20 tires; optional with 8.25-20 tires.

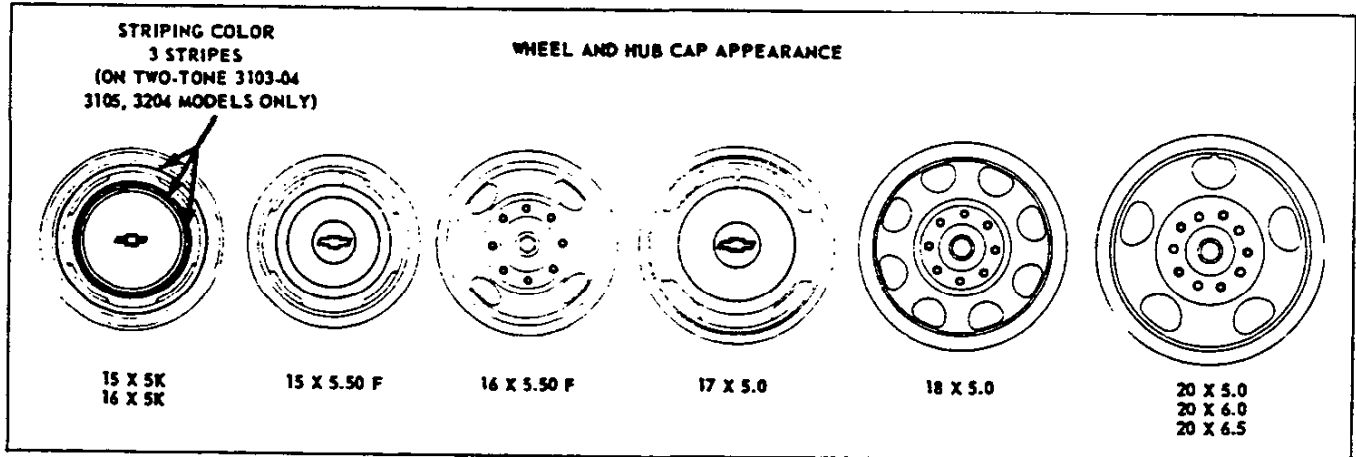

3-25-55. Revised: 8-1-55. •-Data revised.

LOAD CAPACITY CHART

GROSS VEHICLE WEIGHTS FOR 1955 CHEVROLET TRUCKS AND SCHOOL BUSES

VEHICLE TYPE	MODEL AND SERIES DESIGNATION		WHEEL BASE	NOMINAL RATING	GROSS VEHICLE WEIGHT	TIRES AND EQUIPMENT		EQUIPMENT		
						TIRE SIZE & PLY RATING FRONT	REAR			
SEDAN DELIVERY	1508	D55	115		\$4000	6.70-15-4	6.70-15-4			
					4100	6.70-15-6	6.70-15-6			
LIGHT DUTY CONVENTIONAL	3100 3200	H255 M255	114 123-1/4	1/2 Ton	\$4000	6.70-15-4	6.70-15-4			
					4400	6.70-15-6	6.70-15-6			
					*5000	6.50-16-6 15-6	6.50-16-6 15-6	8 leaf rear spring		
MEDIUM DUTY FORWARD CONTROL	3400 3500 3700	F255 G255 K255	104 125 137	3/4 Ton	\$6600	7.00-17-6	7.00-17-6			
					7000	7.00-17-6	7.00-17-8			
					7500	7.00-17-6	7.50-17-8			
					*10000	7.00-18-8	7.00-18-8Dual	H. D. 3-spd trans; H. D. front & rear axle; H. D. 10 leaf front spring; H. D. 8 leaf and 5 leaf aux rear spring		
MEDIUM DUTY CONVENTIONAL	3600	J-255	123-1/4	3/4 Ton	\$5400	15-6	15-6			
					5400	7.00-17-6	7.00-17-6			
					5800	15-6	15-8	10 leaf two-stage rear spring		
						7.00-17-6	7.00-17-8			
					*6900	7.00-17-6	7.50-17-8	H. D. 10 leaf single stage rear spring		
						6.50-16-6	6.50-16-6Dual			
3800	L255	135	1 Ton	\$6200	7.00-17-6	7.00-17-8				
				7000	7.00-17-6	7.50-17-8	H. D. 8 leaf single stage rear spring			
				*8800	7.00-18-8	7.00-18-8Dual	H. D. 8 leaf & 5 leaf aux. rear spring			
HEAVY DUTY	4100 4400	N-255 P-255	130 154	1-1/2 Ton Conventional	\$10000	6.50-20-6	6.50-20-6 Dual			
					11000	6.50-20-6	7.00-20-8 Dual			
					12500	6.50-20-6	7.00-20-10Dual	Hydrovac		
					*14000	7.00-20-8	7.50-20-8 Dual	H. D. 10 leaf & 5 leaf aux. rear spring & Hydrovac		
	5100S 5400S 5700S 6100S 6400S 6500S 5100 5400 5700 6100 6400 6500 5100 5400 5700 6100 6400 6500	SS-255 ST-255 SU-255	112-5/8 136-5/8 160-5/4	130 154 172	1-1/2 Ton Special L. C. F.	\$14000	7.50-20-8	7.50-20-8 Dual		
						*15000	7.50-20-8	8.25-20-10 Dual		
						\$14000	7.50-20-8	7.50-20-8 Dual		
						*15000	7.50-20-8	8.25-20-10 Dual	H. D. 10 leaf front spring	
		S-255 T-255 U-255 V-255 W-255 X-255	130 154 172	112-5/8 136-5/8 160-5/8	130 154 172	2 Ton L. C. F.	\$14000	7.50-20-8	7.50-20-8 Dual	
							*16000	7.50-20-8	8.25-20-10 Dual	
							\$14000	7.50-20-8	7.50-20-8 Dual	
							*16000	7.50-20-8	8.25-20-10 Dual	H. D. 10 leaf front spring
							\$14000	7.50-20-8	7.50-20-8 Dual	
							*16000	7.50-20-8	8.25-20-10 Dual	H. D. 10 leaf front spring
							\$14000	7.50-20-8	7.50-20-8 Dual	
							*16000	7.50-20-8	8.25-20-10 Dual	H. D. 10 leaf front spring
							\$18000	8.25-20-10	8.25-20-12Dual 9.00-20-10Dual	Jobmaster Engine; H. D. Sgle. spd. or two-spd. rear axle; H. D. drive line; H. D. 10 leaf front spring; H. D. 13 leaf & 6 leaf aux. rear spring
							SCHOOL BUS CHASSIS	4502	R-255	154
*12000	6.50-20-6	7.00-20-8 Dual								
\$14000	7.50-20-8	7.50-20-8 Dual								
*16000	7.50-20-8	8.25-20-10 Dual								
6702	Y-255	194	42 Pupils	\$14000	7.50-20-8	7.50-20-8 Dual				
				*16000	7.50-20-8	8.25-20-10 Dual				
				\$14000	7.50-20-8	7.50-20-8 Dual				
				*16000	7.50-20-8	8.25-20-10 Dual				
6802	Z-255	220	44 Pupils	\$14000	7.50-20-8	7.50-20-8 Dual				
				*16000	7.50-20-8	8.25-20-10 Dual				
				\$16000	7.50-20-8	8.25-20-10 Dual				
				*18000	8.25-20-10	8.25-20-12Dual 9.00-20-10Dual	Jobmaster Engine; H. D. sgle. or two-spd. rear axle; H. D. drive line; H. D. 15 leaf two-stage rear spring			

\* - A plate is supplied with each vehicle showing chassis number and maximum Gross Vehicle Weight (GVW). The maximum GVW rating includes the truck chassis with lubricants, water and full tank or tanks of fuel, plus the weight of the cab or driver's compartment, body, and special chassis and body equipment, and payload. These GVW ratings are reduced per above table when tires and/or equipment of lesser capacity are used. Series D55 plate shows no GVW.  
 † - Base GVW, tires shown included in base price  
 Extra ply rating and/or oversize tires and equipment are available with no increase in gross vehicle weight rating.

State of Michigan  
 County of Oakland

On this 9th day of February, 1955 personally appeared before me, R. S. Plexico, known to me as such who makes oath that the data on this sheet are true as represented.

*R. S. Plexico*  
 My commission expires July 28, 1957  
 Acting in Wayne County Michigan

3-25-55  
 CHEVROLET 1955 SPECIFICATIONS - TRUCK

February 9, 1955  
 The data on this sheet are true as represented.  
 CHEVROLET-CENTRAL OFFICE  
 ENGINEERING DEPARTMENT  
 DIVISION OF GENERAL MOTORS CORPORATION

*R. S. Plexico*  
 R. S. Plexico  
 Asst. Chief Engineer  
 Truck Chassis

LOAD CAPACITY CHART - 145



**BUMPERS**

		WRAP-AROUND TYPE				CHANNEL-TYPE		WRAP-AROUND TYPE	
		CHANNEL-TYPE							
ITEM		3102-03-04-12; 3204; 3002-03-04-08-09-12; 3802-03-04-08-09-12	3105-00-16; 3805	3124	34-35-3700	4-5-6000			
Standard or Optional	Front	Standard			Optional	Standard			
	Rear	Optional	Standard		None Available				
Type	Front	Wrap-around passenger car type section			Channel				
	Rear	Wrap-around passenger car type section		5-Piece*					
Material	Front	Spring steel			Hot rolled steel				
	Rear								
Gauge	Front								
	Rear	.149			.1196	.2092			
Overall width	Front	75.313			79.25				
	Rear	75.313 (70.375 on 4's)		73.75					
Overall height	Front	6.75			8				
	Rear	6.75			8.063				
Finish	Front	Painted (Chrome RPO)			Chrome	Painted			
	Rear				¢				

\* - 2 outer bars, 2 intermediate face bars and 1 hinged center face bar.

¢ - Chromed bumperettes and outer face bar; Painted intermediate and center face bar

**LIGHTS AND HORNS**

(Units listed below are shipped loose on Series 34-35-3700)

**HEADLIGHTS**

Make and type ----- Guide, Sealed Beam  
 Location ----- In front fender faces  
 Sealed Beam Unit Diameter ----- 7  
 Lens diameter ----- 6.688  
 Dimmed by ----- Foot switch (depresses beam)  
 Beam indicator location ----- In speedometer face

**REAR LICENSE LIGHTS**

Cameo Carrier -----  
 -----Two housed in rear bumper center face  
 All others ----- Illuminated through window in combination Tail & Stop Light

**PARKING LIGHTS**

Location---In front fender face below the headlights

**DOME LIGHTS**

Number ----- One, all except F/F & W/S models

**LIGHTING SWITCHES**

Make ----- Delco-Remy  
 Main switch ----- 3-Position, mounted on instrument panel. Incorporates a rheostat, operated by rotating the switch knob, which controls the brightness of the instrument panel lights.  
 Stop light switch-----Mechanical, on toe board  
 Dome light switch ----- Incorporated in main switch, operated by rotating switch knob to extreme travel

**DUAL CIRCUIT BREAKER**

Type and location ----- Bi-Metal thermal elements incorporated in main switch  
 Capacity (Each circuit) ----- 15 amperes

**HORN**

Make and type ----- Delco-Remy; vibrator, low-note  
 Location ----- Bolted to radiator upper tie bar  
 Current drain ----- 9-10 amperes

**BULBS**

USED IN	QUANTITY	TRADE NO.	POWER	USED IN	QUANTITY	TRADE NO.	POWER
Parking lights	2	67	3 cp	Tail and stop lights	3124	2	1034* 4 cp 32 cp
Instrument cluster	3	57	2 cp		All Others	1	
Beam indicator	1	53	1 cp		RPO 249	2	
Ignition lock		94	15 cp		License lights	3124	
Dome light				Pickup#	1	67	3 cp
Head Upper beam lights	2	2433 or 4400*	50 W				
Lower beam			40W				

# - Pickup models with RPO rear bumper, License light at center below tail gate. \* - Single bulb, double filament  
 3-25-55. Revised: 8-1-55 •Data Corrected

## INSTRUMENTS

Make ----- AC  
 Type -----  
 Fuel gauge ----- Electric  
 Ammeter ----- Electric  
 Oil gauge ----- Pressure  
 Cooling system heat indicator ----- Pressure  
 Speedometer -----  
 ----- Dial, driven by flexible shaft from transmission

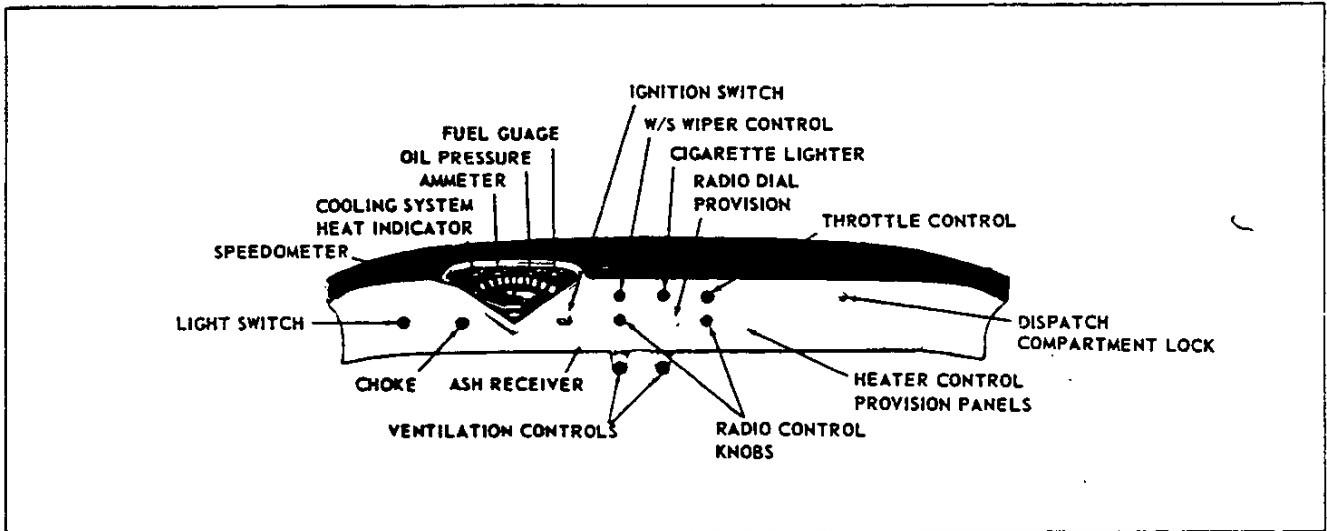

### SPEEDOMETER GEARS \*

ITEM		3100, 3200	34, 35, 3700	3600	3800	4000	5000	6000
3-Speed transmission		Regular						
3-Speed overdrive		RPO 315						
3-Speed H. D.		RPO 316						
4-Speed transmission		RPC 318			Regular			
4-Speed auto. trans.		RPO 314						
Rear axle		Regular						
		3.90:1	5.14:1	4.57:1	5.14:1	6.17:1		
Teeth	Drive	7	6		4			
	Driven	20		19	13	15	14	
Pitch	Drive	30				22		
	Driven							

\* - All figures shown for gear teeth and pitch are based on standard tires, axles, and transmissions. For speedometer gear fitting equipment see RPO's 306 and 307 and speedometer gear chart 3718238.

### SPEEDOMETER GEAR ADAPTERS

The following speedometer gear adapters are available through the Service Department for correction of speedometer and odometer errors that sometimes occur when combinations of tires, transmission and rear axle, other than standard, are specified.

Service Package Number	156584	1565813	1565812	1583876
Gear Ratio	16:1	17:15	17:16	18:14

### TOOLS

ITEM		3100, 3200	3600	3400, 3500, 3700, 3800	4000, 5000, 6000
Jack	Capacity (pounds)	1300			8250
	Raised height	14.34		15.70	18
	Lowered height	6.25		7.62	8.87 <sup>a</sup>
Jack handle		Also used as changing iron			
Tire changing iron		With RPO 273 §		All	
Wrench					

§ - 3100 and 3200 only

3-25-55, Revised: 8-1-55, <sup>a</sup>-Data Revised

CHEVROLET 1955 SPECIFICATIONS - TRUCK

INSTRUMENTS - 147

### ACCESSORIES

Definition: Items made available at extra Cost through the Parts and Accessories Department and installed by the customer or his dealer.

ITEM	DESCRIPTION	APPLICABLE TO *
Alarm	Parking brake	3100-3200-34-35-3700-3600
Antenna	Radio, rod type (fender mounting)	All
Arm Rests	Beige, for L. H. or R. H. door	All cabs & single unit bodies
Cap	Gas tank filler, locking	All
Caps	Hub, stainless steel	All 3000 except 3124
Deflectors	Rain (Ventshades)	All
Flaps	Mud	All stakes & platforms
Frame	License plate	All
Guard	Bumper, for curved type face bar (painted or plated)	All 3000 except flat face cowl
	Bumper, for channel type face bar (painted)	All
	Grill, brush type (painted)	All
Heater	With defroster	All
	Air Flow Recirculating	
Horn	High note (vibrator)	All except 5000
Kit	Tool	All
Lamp	Back-up	All pick-ups & single units
	Fog (dual)	All
	Spot, with bracket	All with cigarette lighter
	Spot, portable	All except single unit bodies
	Tail and Stop, R. H.	All except 34-35-3700
	Underhood	All
	Glove compartment	All
	Directional signal, Front and Rear	All except 34-35-3700, Pick-ups & Single units
Lighter	Cigarette	All except 34-35-3700
Mat	Floor, rectangular	All
Mirror	Rear view, outside, door mounted	3000
	Rear view, outside, extension type	All
	Rear view, inside, non-glare	All
Ornament	Hood	All except 5000
Paint	Touch-up	All
Radio	Delco- Manual, with antenna	All
Reflector	Reflex (4 inch) red	All
Shaver	Electric	All with cigarette lighter
Step Unit	Rear	All stakes & platforms
Sunshade	Right Hand	All, standard on 3106-16
Visor	Sun, outside mounted	All cabs & single unit bodies
Washer	Windshield, foot operated	All except 34-35-3700

\* - In most cases application of items is made generally to series rather than to each individual model. For further information see Accessory Literature.

**REGULAR PRODUCTION OPTIONS**

RPO	ITEM	SERIES*
200	Shock Absorbers, Direct double acting.	3800-4000-5000-6000
201	Two-Speed Rear Axle, 8.72/6.40:1	5000-6000
202	Two-Speed Rear Axle, 7.95/5.83:1	5000-6000
203	Heavy Duty Front Axle	4100-4400
210	Rear View Mirror, Long and Short, Left and Right Side	All except FWD Controls
211	Rear Shock Absorber Shield	31-32-34-35-36-3700
212	Power Brakes, Long Stroke; 6.75 piston diameter	4000
213	Power Brakes, Short Stroke; 6.75 piston diameter	3000
216	Oil Bath Air Cleaner, 1 and 2 pint capacity	31-32-36-3800-4000
217	Engine Positive Ventilation	All except FWD Controls & LCF
218	Rear Bumper, One piece Wrap-around	3100-3200-3600-3800
225 •	Heavy Duty Engine (235 Loadmaster and 261 Jobmaster)	4000-6000
227	Heavy Duty Clutch, 11 diameter	31-32-36-3800
230	Platform Body	3600
234 •	Solid Colors	All
237	Oil Filter 1 and 2 quart capacity	31-32-36-3800-4000-6000
241	Engine Governor	All
243	Two-Speed Rear Axle, 7.95/5.83:1 (4000)	4000
249	Dual Tail and Stop Lamp	3100-3800
252	Heavy Duty Single Speed Rear Axle (6.17:1 and 7.20:1)	5000-6000
253 x	Heavy Duty Front Springs	6100-6400-6500
254	Heavy Duty Rear Springs	All except FWD Controls
256	Heavy Duty Radiator (18.5 quart capacity)	All except FWD Controls & LCF
258	Foam Rubber Seat	All Cabs
263	Auxiliary Seat	3100-3800
267	Rear Spring, Main and Auxiliary	3800-4100-4400
269	Air Cushion Seat	All Cabs
281	Vacuum Power Brake Reserve Tank	4000-5000-6000
291 •	20 x 6.5 Wheels (For 8.25-20 and 9.00-20 Tires)	5000-6000
306	Speedometer Fitting Equipment	3600-4000-5000-6000
307	Speedometer Fitting Equipment	3000
314	Automatic Transmissions, With or Without Oil Cooler	3000
315	Overdrive Transmission	3100-3200
316	3-Speed Heavy Duty Transmission	3000
318	4-Speed Transmission	31-32-34-35-36-3700
320	Dual Electric Windshield Wipers	All
326	Generator, 30 and 40 ampere	All
340	Fuel and Vacuum Booster Pump	All School Buses
341 x	Side Mounted Spare Wheel Carrier	All Pick-Ups
345 x	Heavy Duty 70 Amp Battery	All except School Buses
350	Power Steering (6 Cylinder Engines)	All except FWD Controls
351 x	Power Steering (8 Cylinder Engines)	All except FWD Controls
367	Front Bumper (Channel Type)	All FWD Control Models
384	Wheel Carrier	All FWD Control Models
391	Hydraulic Auto Jack (5 ton capacity)	4000-5000-6000
393	Chrome Equipment	3100-3200-3600-3800
394	Wrap-around Rear Window	All Cabs
395 •	Lock Equipment	All Cabs, Panels & Pick-Ups
399	Body Tinted Glass	All Cabs & Panels
401	Stake Racks	All Stake Models
402	Identification Plate ("S" Series) 15000 GVW	5000-6000
403	Identification Plate (18000 GVW)	5000
404	Identification Plate (18000 GVW)	6000
408 x	V-8 Engine	3100-3200-3600
409 x	V-8 Engine	3800-4000-6000
414	Heavy Duty Hydraulic Power Brakes	5000-6000
423 x	Running Board	3100
430	Deluxe Equipment (6 Cylinder Engine)	All except FWD Controls & LCF
431 x	Deluxe Equipment (8 Cylinder Engine)	All except FWD Controls
443	Color Combination, Two-Tone (Cabs)	All Cabs
444	Color Combination, Custom Two-Tone (Cabs)	All Cabs
445	Color Combination, Two-Tone (3105)	3100
446	Color Combination, Two-Tone (3805)	3800

NOTE: For information on RPO Tires, see page 144 •

\* - For model applications, see Regular Production Option Book

ANTI-FRICTION BEARINGS

BEARING FUNCTION		GM PART NUMBER	TYPE	1500 2100 2400	3100	3200	3400	3500	3600	3700	
Rear axle	Pinion front	7450373	Taper Roller	1	1	1					
		442093	DR Taper Roller				1	1	1	1	
		954237	DR Ball								
	Pinion rear	7450371	Taper Roller	1	1	1					
		189436	Roller				1	1	1	1	
		7450382	Roller								
		144553	Roller								
	Differential	7450438	Barrel Roller	2	2	2					
		188930	Barrel Roller				2	2	2	2	
		148399	Barrel Roller								
		7450326	Barrel Roller								
		144527	Barrel Roller								
144527		Barrel Roller									
Rear Wheel	Inner	188930	Barrel Roller				2	2	2	2	
		144527	Barrel Roller								
		7450320	Barrel Roller								
	Outer	954561	SR Ball	2							
		111121	Roller		2	2					
		188932	Barrel Roller				2	2	2	2	
		144525	Barrel Roller								
7450323	Barrel Roller										
Front Wheel	Inner	909040	SR Ball	2							
		909052	SR Ball		2	2					
		909046	SR Ball				2	2	2	2	
		7450335	Taper Roller								
	Outer	909041	SR Ball	2							
		909001	SR Ball		2	2					
		909045	SR Ball				2	2	2	2	
7450336	Taper Roller										
U-Joint & Propeller Shaft	Trunnion assy	Front	3707062	Needle	4						
			606866	Needle		4	4	4	4	4	
			3705199	Needle		4@	4@	4@	4@	4@	
		Fr Center	3705199	Needle			4@		4	4@	
		RR Center	3705199	Needle							
		Rear	3707062	Needle	4						
			606866	Needle		4	4				
	Support	3705199	Needle				4	4	4	4	
		Front	954257	SR Ball			1@		1	1@	
			Rear	954257	SR Ball						
Water Pump	3836131C	DR Ball	1	1	1	1	1	1	1		
	3704162S	DR Ball	1	1	1	1	1	1	1		
Generator-front	954378	SR Ball	1	1	1	1	1	1	1		
Clutch release	909422	SR Ball	1	1	1	1	1	1	1		
	954221S	SR Ball			1	1			1		

3-25-55. Revised: 8-1-55. e-Data revised  
150 - ANTI-FRICTION BEARINGS

Continued

**ANTI-FRICTION BEARINGS - Continued**

BEARING FUNCTION		GM PART NUMBER	TYPE	1500 2100 2400	3100	3200	3400	3500	3600	3700
Steering gear	Worm thrust	5666693	SR Ball	2						
		179291	Barrel Roller		2	2			2	
		270266	Barrel Roller				2	2		2
		178430	Barrel Roller							
	Sector roller	266800	Ball	54	60	60	100	100	60	100
	Strg Column upper	5667239	SR Ball	1						
	Strg Column upper	270255	SR Ball		1	1	1	1	1	1
Conventional 3-Speed transmission	Counter shaft front	435847	Needle	1	1	1	1	1	1	1
	Countershaft rear	435847	Needle	1	1	1	1	1	1	1
	Transmission rear bearing	954886	SR Ball	1	1	1	1	1	1	1
	Mainshaft Pilot front	435844	Needle	1	1	1	1	1	1	1
	Mainshaft Pilot rear	7450247	Needle	1	1	1	1	1	1	1
	Clutch gear	954388	SR Ball	1	1	1	1	1	1	1
4-Speed transmission	Countershaft front	142260	Roller		1	1	1	1	1	1
	Countershaft rear	954164**	SR Ball		1	1	1	1	1	1
	Mainshaft Pilot front	7450010	Needle		1	1	1	1	1	1
	Mainshaft Pilot rear	954869	SR Ball		1	1	1	1	1	1
	Clutch gear	954358	SR Ball		1	1	1	1	1	1
3-Speed heavy duty transmission	Clutch gear	954127	SR Ball		1	1	1	1	1	1
	Mainshaft rear	954829	SR Ball	1						
	Mainshaft rear	954390	SR Ball		1	1	1	1	1	1
	Countershaft front & rear	3709328	Needle		4	4	4	4	4	4
	M/Shaft Pilot	7450010	Needle		1	1	1	1	1	1
3-Speed overdrive transmission	Countershaft front	435847	Needle	1	1	1				
	Countershaft rear	435847	Needle	1	1	1				
	Mainshaft Pilot front	435844	Needle	1	1	1				
	Mainshaft Pilot rear	7450247	Needle	1	1	1				
	Clutch gear	954388	SR Ball	1	1	1				
	Output shaft	954862	SR Ball		1	1				
	Drive shaft	954813	SR Ball		1	1				
RPO 313 Auto. transmission	Mainshaft	954862	SR Ball	1						
	Planet pinions	3689731	Needle	6						
RPO 314 Hydra-matic transmission	Mainshaft rear	903006	SR Ball		1	1				
	Mainshaft rear	9003007	SR Ball				1	1	1	1
	Planet Pinion	440483	Needle		9	9	9	9	9	9
	Rear band lever	440483	Needle		1	1	1	1	1	1
<b>Total per base vehicle</b>				<b>31</b>	<b>31</b>	<b>31</b>	<b>33</b>	<b>38</b>	<b>33</b>	<b>38</b>

\* 2-Speed axle 8.72/6.4:1

‡ 2-Speed axle 5.83/7.95:1

+ Heavy duty single speed axle

‡ Heavy duty front axle

@ 3-Speed heavy duty or 4-Speed transmission

§ Automatic transmission

† With 6-cylinder engine

§ 8-cylinder engine

\*\* Will be replaced by 901604 when stock of 954164 is exhausted

Continued

3-25-55

CHEVROLET 1955 SPECIFICATIONS - TRUCK

ANTI-FRICTION BEARINGS - 151

ANTI-FRICTION BEARINGS - Continued

BEARING FUNCTION		GM PART NUMBER	TYPE	3800	4100 4400	4500	5100 5400	5700	6100 6400	6500 6700 6800	
Rear Axle	Pinion front	7450373	Taper Roller								
		442093	DR Taper Roller	1	1*	1*	1	1	1+**	1+**	
		954237	DR Ball		1	1			1	1	
	Pinion rear	7450371	Taper Roller								
		189436	Roller	1							
		7450382	Roller		1*	1*	1	1	1+**	1+**	
		144553	Roller		1	1			1	1	
	Differential	7450438	Barrel Roller								
		188930	Barrel Roller	2							
		148399	Barrel Roller		2	2					
		7450326	Barrel Roller						2	2	
		144527	Barrel Roller				2	2	2+	2+	
144527		Barrel Roller		1*	1*	1+*	1+*	1+*	1+*		
7450358		Barrel Roller		1*	1*	1+*	1+*	1+*	1+*		
Rear Wheel	Inner	188930	Barrel Roller	2							
		144527	Barrel Roller		2	2					
		7450320	Barrel Roller		2*	2*	2	2	2	2	
	Outer	954861	SR Ball								
		111121	Roller								
		188932	Barrel Roller	2							
		144525	Barrel Roller		2	2					
		7450323	Barrel Roller		2*	2	2	2	2	2	
Front Wheel	Inner		SR Ball								
		909052	SR Ball								
		909046	SR Ball	2	2						
		7450335	Taper Roller		2*	2	2	2	2	2	
	Outer	909041	SR Ball								
		909001	SR Ball								
		909045	SR Ball	2	2						
7450336	Taper Roller		2*	2	2	2	2	2			
U-Joint & Propeller Shaft	Trunnion Assy	Front	3707062	Needle							
			606868	Needle							
			3705199	Needle	4	4	4	4	4	4	
		Fr Center	3705199	Needle	4	4	4	4	4	4	
		Rr Center	3705199	Needle				4		4	
		Rear	3707062	Needle							
			606868	Needle							
	Support	Front	3705199	Needle	4	4	4	4	4	4	
		Rear	954257	SR Ball	1	1	1	1	1	1	
			954257	SR Ball					1	1	
Water Pump		3836131	DR Ball	1	1	1	1	1	1		
		37041625	DR Ball	1	1	1	1	1	1		
Generator-front		954375	SR Ball	1	1	1	1	1	1		
Clutch release		909422	SR Ball	1	1	1			1		
		9542215	SR Ball	1	1	1	1	1	1		

3-25-55, Revised: 8-1-55, -Data Revised Continued

ANTI-FRICTION BEARINGS - Continued

BEARING FUNCTION		GM PART NUMBER	TYPE	3800	4100 4400	4500	5100 5400	5700	6100 6400	6500 6700 6800
Steering gear	Worm thrust	5666693	SR Ball							
		179291	Barrel Roller	2						
		270266	Barrel Roller				2	2		
		178480	Barrel Roller		2	2			2	2
	Sector roller	266800	Ball	60	106	106	100	100	106	106
	Strg column upper	5667239	SR Ball							
	Strg column upper	270255	SR Ball	1	1	1	1	1	1	1
Conventional 3-Speed transmission	Countershaft front	435847	Needle							
	Countershaft rear	435847	Needle							
	Transmission rear bearing	954886	SR Ball							
	Mainshaft Pilot front	435844	Needle							
	Main shaft Pilot rear	7450247	Needle							
	Clutch gear	954388	SR Ball							
4-Speed transmission	Countershaft front	142260	Roller	1	1	1	1	1	1	1
	Countershaft rear	954164**	SR Ball	1	1	1	1	1	1	1
	Mainshaft Pilot front	7450010	Needle	1	1	1	1	1	1	1
	Mainshaft Pilot rear	954869	SR Ball	1	1	1	1	1	1	1
	Clutch gear	954358	SR Ball	1	1	1	1	1	1	1
3-Speed heavy duty transmission	Clutch gear	954127	SR Ball	1						
	Mainshaft rear	954829	SR Ball							
	Mainshaft rear	954390	SR Ball	1						
	Countershaft front & rear	3709328	Needle	4						
	M/shaft pilot	7450010	Needle	1						
3-Speed overdrive transmission	Countershaft front	435847	Needle							
	Countershaft rear	435847	Needle							
	Mainshaft Pilot front	435844	Needle							
	Mainshaft pilot rear	7450247	Needle							
	Clutch gear	954388	SR Ball							
	Output Shaft	954862	SR Ball							
	Drive Shaft	954813	SR Ball							
RPO 313 Auto. transmission	Mainshaft	954862	SR Ball							
	Planet pinions	3689731	Needle							
RPO 314 Hydra-matic transmission	Mainshaft rear	903006	SR Ball							
	Mainshaft rear	903007	SR Ball	1						
	Planet pinion	440483	Needle	9						
	Rr band lever	440484	Needle	1						
Total per base vehicle				37	37	37	37	42	37	42

\* 2-Speed axle 8.72/6.4:1

± 2-Speed axle 5.83/7.95:1

+ Heavy duty single speed axle

‡ Heavy duty front axle

@ 3-Speed heavy duty or 4-Speed transmission

§ Automatic transmission

¢ With 6-cylinder engine

§ 5-cylinder engine

\*\* Will be replaced by 901604 when stock of 954164 is exhausted

3-25-55

CHEVROLET 1955 SPECIFICATIONS - TRUCK

ANTI-FRICTION BEARINGS - 153



INDEX.

	PASSENGER	TRUCK		PASSENGER	TRUCK
Accessories	19	148	Finish, exterior		102
Air cleaner	39, 48	126, 138	Firing order	41, 50	129, 139
Alignment, wheel	29	104	Flywheel	51	140
Anti-friction bearings	150, 153	150, 153	Frame, chassis	28	103
Automatic transmission	54	142	Front suspension	28, 29	105
Axle, front		104	Fuel pump	39, 48	127, 138
Axle, rear	31	106, 107	Fuel system	39, 48	126, 138
Axle rear, two-speed		112	Fuses, lighting		146
Battery	49, 49	128, 138	Gear reduction, rear axle	31	106-107
Bearings, anti-friction	150, 153	150, 153	Gear reduction, total	31	106-107
Bearings, crankshaft & camshaft	36, 45	123, 134	Gear reduction, transmission	52, 54	141
Belt, engine fan	40, 49	126, 137	Gearshift	22	141
Body dimensions	12-18	64-98	Generator	40, 49	128, 138
Body glass	27		Glass, body	27	
Brakes power	31	117	Governor, engine		118, 132
Brakes	31-32	117	Grill, radiator		102
Breaker points	41, 50	129, 139	Gross vehicle weight		145
Bulbs, light	56	146	Guards, propeller shafts		113, 114
Bumpers		146	Guides, valve stem	38, 47	125, 136
Cab dimension		101	Harmonic balancer	36, 45	123, 134
Camber, wheel	29	104	Headlights	56	146
Camshaft	36, 45	123, 134	Height, vehicle overall	11	64-98
Carburetor	39, 48	126, 138	Hood		102
Caster, wheel	29	107	Horns	56	146
Chassis dimension		64-98	Horsepower	33-35, 42-45	120-122, 133
Circuit breaker	56	146	Hoses, radiator	40, 49	126, 137
Clutch	51	140	I-Beam, front axle		104
Coil, ignition	41, 50	129, 139	Identification, model	8	62
Colors, exterior	24, 25		Ignition system	41, 50	128, 139
Colors, interior	24, 25		Instrument panel & instruments	20-21	147
Condenser, distributor		129, 139	Interior dimensions	12-18	64-98
Connecting rods	37, 46	124, 135	Interior upholstery	26-27	
Controls (hydraulic)			King pin		104
Automatic transmission	54		Length, vehicle overall	11	64-98
Converter, torque	50		License lights	56	146
Cooling system, engine	47, 49	125, 137	Lifters, valve hydraulic	38, 47	136
Corvette specifications	57-63B		Lights	56	146
Cowl dimension		100	Load capacity chart		145
Crankshaft	36, 45	123, 134	Lock ignition	41, 50	128, 138
Cut-out relay	47, 49	125, 137	Lubricant, engine	39, 48	127, 137
Current regulator	40, 49	126, 138	Lubricant, rear axle	31	106-107
Cylinder case and head	36, 45	123, 134	Lubricant, steering gear	55	
Differential	31	106-107	Lubricant, transmission	52-54	141
Dimmer switch	56	146	Lubrication system, engine	39-48	127, 137
Direction signal	56		Luggage compartment capacity	12-18	
Distributor	41, 50	129, 139	Main cylinder, brake	32	117
Dome light	56	146	Model identification	8	62
Driver compartment dimensions		101	Mounting, power plant engine	33, 42	129, 139
Drive system	32	107, 108	Muffler	39, 48	127, 138
Electrical system, engine	40-41, 49-50	128, 138	Octane selector	39	127
Engine	33-41, 42-50	120-139	Oil pump	39, 48	127, 138
Engine basic design data	33, 42	120-139	Options, regular production	20	149
Engine, power plant mounting	33, 42	124, 134	Pan, oil	39, 48	127, 137
Engine performance		120-122, 133	Parking brake	32	117
Exhaust system	39, 48	127, 138	Parking lights	56	146
Exterior dimensions	11	64-98	Performance, car	33, 42	
Fan, engine	40, 49	126, 137	Performance, curves	34-35, 43-44	120-122, 133
Filler, crankcase oil	39, 48	127, 137			
Filter, oil	39, 48	127, 137			

INDEX - Continued. •

	PASSENGER	TRUCK		PASSENGER	TRUCK
Performance, engine	34-35, 43-44	120-122, 133	Suspension, front	28-29	105
Pipe, tail and exhaust	39, 48	127, 138	Suspension, rear	30	108-111
Pistons, pins, and rings	37, 46	124, 135	Switches, lighting	56	146
Piston travel	33, 42	118-119, 133			
Planetary gear unit	54				
Power take-off		141	Tail lights	56	146
Propeller shaft	32	113-114	Tank, fuel	39, 48	126, 138
Propeller shaft brake		117	Tappets	38, 47	125, 136
Pump, fuel	39, 48	127, 138	Thermostat, coolant	40, 49	126, 137
Pump, oil	3, 48	127, 137	Thermostat, manifold		
Pump, water	40, 49	126, 137	heat control	39, 48	126, 137
			Timing engine	41, 50	129, 139
Radiator core	40, 49	126, 137	Timing gears	36, 45	123, 134
Radiator grille		102	Tires	53	144
Ratios, rear axle	31	106-107	Toe-in, wheel	29	104
Rear axle and drive	31	106-107	Toe-out, on turns	29	104
Rear axle, two-speed		112	Tools	56	147
Rear suspension	30	108-111	Torque, axle shaft	31	106-107
Regular equipment	20-21		Torque converter	54	
Regular production options	20	149	Torque engine	33-35, 42-44	120-122, 133
Regulator, voltage & current	40, 49	128, 138	Transmission, Automatic	54	142
Ride stabilizer		104, 180-111	Transmission, conventional	52	141
Rings, piston	37, 46	124, 135	Transmission, overdrive	53	
Rocker arms, valve	38, 47	125, 136	Treads, chassis	11	99
			Trim, interior	22-27	
			Tubes, tire		144
Seat dimensions	12-18	101	Turning diameters	55	143
Seats, valve	38-47	125, 136	Two-speed rear axle		112
Serial numbers	9	63			
Shackles, front spring		105	Universal joints	32	113-114
Shackles, rear spring	30	108-111	Upholstery	26-27	
Shock absorbers, front	28	105			
Shock absorbers, rear	30	108-111	Valve lifters, hydraulic	38, 47	136
Spare wheel mounting	12-18		Valve train	38, 47	125, 136
Spark advance, automatic	41-50	129, 139	Ventilation, crankcase	39, 48	127
Spark plugs	41-50	128, 130	Vibration damper	36, 45	123, 134
Speedometer gears	52-53	147	Voltage and current regulator	40, 49	128, 138
Splines, drive system	32	115-116			
Springs, front	28	105	Water pump	40, 49	126, 137
Springs, rear	30	108-111	Weights, gross vehicle		145
Springs, valve	38, 47	125, 136	Weights performance	10	
Stabilizer, ride		104, 108, 111	Weights, power plant	33, 42	110, 122
Starting motor	40, 49	128, 138	Weights, shipping and curb	10	
Steering gear	55	143	Wheels	53	144
Steering knuckles	29	104	Wheel alignment	29	104
Steering linkage	55		Wheelbase	11	64-98
Steering wheel	55	143	Wheel travel	28	
Stop lights	56	146	Width, vehicle overall	11	64-98
Support bearing, propeller shaft		113-114	Windshield	27	100
			Windows	11, 27	100



.

.

.



## SERIAL NUMBERS

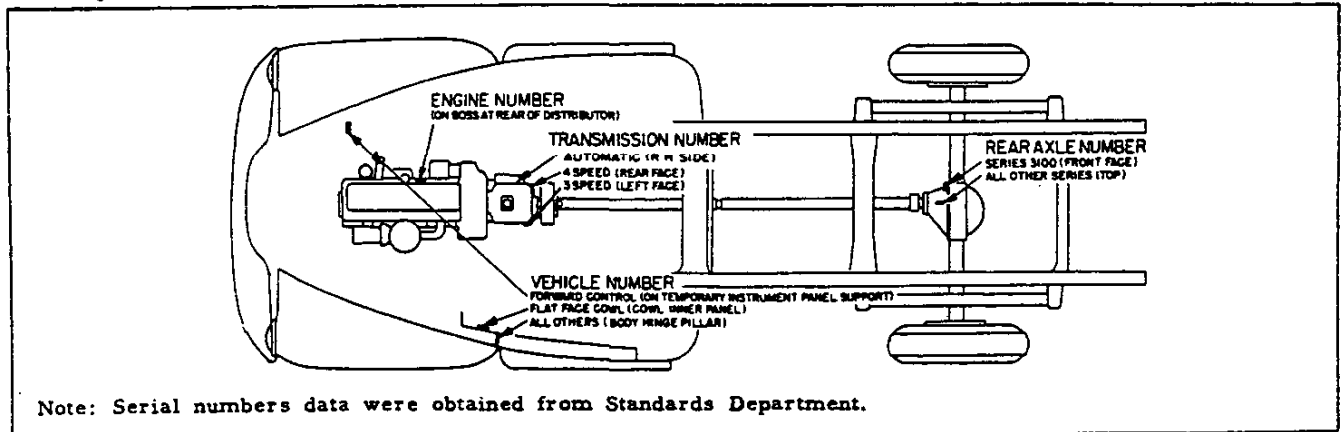

Note: Serial numbers data were obtained from Standards Department.

### VEHICLE SERIAL NUMBER

Example: **L 55 K 001803**

Series	Model	Year	Assembly Plant	Unit Number
H	3100		T Tarrytown	
J	3600		F Flint	
K	3700		S St. Louis	
L	3800		K Kansas City	
M	3900		O Oakland	
N	4100		A Atlanta	
P	4400		N Norwood	
R	4500		B Baltimore	
S	5100	*SS 5100S*	L Los Angeles	
T	5400	ST 5400S	J Janesville	
U	5700	SU 5700S		
V	6100	SV 6100S		
W	6400	SW 6400S		
X	6500	SX 6500S		
Y	6700			
Z	6800			

\*-S, Used on 1-1/2 ton specials only

Unit numbers begin with 1001 at each plant regardless of series.

### TRANSMISSION IDENTIFICATION

Three Speed regular and four speed

Example: **T 2 07**

Plant & type design	Month	Day of Month
Prefix	Plant	Type
M	Muncie	3-Speed
T	Toledo	4-Speed

Automatic Transmission Identification

Series	3100	36-37-38-3900
Plate color	Orange	Black
Plate location	On right hand side of transmission	

### Heavy Duty Three Speed Transmission

Example: **W G 15 5 2**

Manufacturer	Month	Day of Month	Year	Work shift
W	G	15	5	2

### ENGINE SERIAL NUMBER

Example: **0601025 F 55 T**

Unit Number	Assembly Plant	Model Year	Type
Flint Tonawanda Series			
F55X	T55X	3100	
F55XA	T55XA	3600	
F55XB	T55XB	3800	
F55U	T55U	3100 with HD clutch (RPO 227)	
F55UA	T55UA	3600 with HD clutch (RPO 227)	
F55UB	T55UB	3800 with HD clutch (RPO 227)	
F55M	T55M	3100 with automatic transmission	
F55MA	T55MA	3600 with automatic transmission	
F55MB	T55MB	3800 with automatic transmission	
F55T	T55T	3700	
F55TA	T55TA	3900	
F55L	T55L	3700 with automatic transmission	
F55LA	T55LA	3900 with automatic transmission	
F55S	T55S	4000	
F55PA	T55PA	4000 HD Engine	
F55R	T55R	5000	
F55Q	T55Q	5000 HD Engine	
F55P	T55P	6000	
F55N	T55N	6000 HD Engine	

Unit numbers begin with 1001 at each plant and continue in sequence.

### REAR AXLE SERIAL NUMBER

Example: **N K 1 02**

Model Year	Type and Assembly Plant	Month	Day of Month
Detroit Buffalo Series			
NK	NY 3100, 3.9 ratio		
NG	NH 3600, 4.57 ratio		
ND	-- 3600, Dual Rear Wheels (RPO 282)		
NC	-- 3600, Dual Rear Wheels & 5.14 ratio (RPO 208)		
NQ	NR 3700, (3600 sgle whls & 5.14 ratio)		
YJ	-- 3800 & 3802 - 12 with RPO 214		
YQ	-- 3802-03-08-12 RPO's 294 & 295 Dual Rear Wheels; 3802-12 Dual Rear Wheels & RPO 214		
YC	-- 3942 & 3942 with RPO 214		
YA	-- 3942 with Dual Rear Wheels; 3942 with RPO 214 & Dual Rear Wheels		
YL	-- 4000, 6.17 ratio		
YE	-- 4000 RPO 204 (5.43:1 ratio)		
YG or YK	-- 5-6000, 6.17 ratio		
YN or YR	-- 5-6000 RPO 202 2-Speed (8.10-6.13 ratio) RPO 243 on 4000		
YS or YD	-- 5-6000 RPO 201 2-Speed (8.86-6.70 ratio)		

CHASSIS AND BODY DIMENSIONS

Model 3102 Flat Face Cowl Chassis  
 Model 3112 Windshield Cowl Chassis

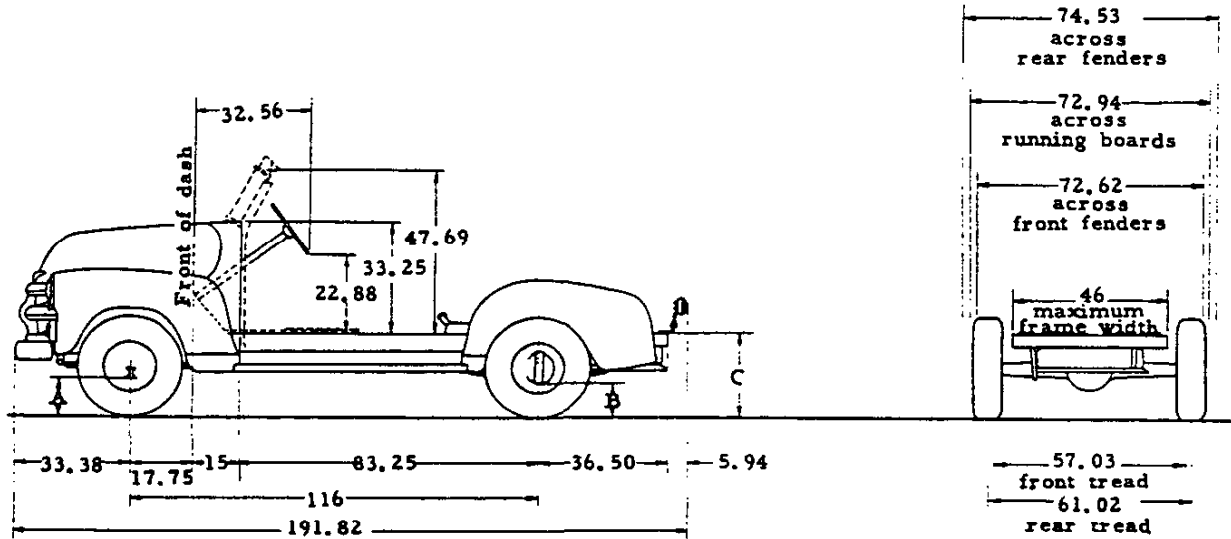

Equipment	Height Without Body and Payload		
	A	B	C
Standard	8.19	8.06	26.25
Minimum for Max GVW	8.19	8.38	26.75

To determine loaded and unloaded heights, body specifications must be known.  
 Minimum tire equipment for Max. GVW is 6.00-16-6pr front and 6.50-16-6pr rear.

VEHICLE WEIGHTS AND LOAD DISTRIBUTION

MODEL	WITH STANDARD EQUIPMENT						WITH MINIMUM EQUIPMENT FOR MAXIMUM GVW			
	Shipping			Curb			Body and Payload	Payload Distribution		Body Length
	Front	Rear	Total	Front	Rear	Total		Front	Rear	
3102 Ⓞ	1545	855	2400	1595	935	2530	2250	Determined by style, length and weight of body.		
3112 Ⓞ	1615	905	2520	1665	985	2650	2100			

Ⓞ-Estimated Weight

10-29-54

64-MODELS 3102 AND 3112 DATA

CHEVROLET 1955 SPECIFICATIONS—TRUCK

**MODEL 3102 LIGHT DUTY FLAT FACE COWL CHASSIS  
MODEL 3112 LIGHT DUTY WINDSHIELD COWL CHASSIS**

1/2 TON NOMINAL RATING --- 116 WHEELBASE --- 4800 lb MAXIMUM GVW

**STANDARD EQUIPMENT**

AIR CLEANER -----AC make; oil-wetted type	FUEL TANK ----- Inside of frame on right side; 16 gallon capacity
AXLE, FRONT ----- I-beam type; 2200 lb capacity	GENERATOR ----- 40 amp maximum rate
AXLE, REAR -----Semi-floating type; 3300 lb capacity; hypoid gears; 3.9 ratio	LIGHTS ----- 2 head, 2 parking and 1 tail and stop
BATTERY----- 15 plate; 100 amp hr capacity	RIDE STABILIZER ----- Frame to front axle
BODY -----None	RUNNING BOARDS ----- Full length
BRAKES	SEAT RISER ----- 3112 only
PARKING ----- Foot operated on rear wheels; 74 sq. in. area	SHOCK ABSORBERS ----- Front and rear; direct double- acting; 1-inch dia piston
SERVICE ----- Hydraulic type; 4 wheel; 158 sq. in.	SPARE WHEEL CARRIER ----- Underslung at rear
FRONT ----- 11 x 2; 84 sq. in. area	SPRINGS, FRONT-- Semi-elliptic; 8-leaf, 38 x 1-3/4; 1000 lb (ea) capacity at ground
REAR ----- 11 x 1-3/4; 74 sq. in. area	SPRINGS, REAR --- Semi-elliptic; 8-leaf, 54 x 1-3/4; 1450 lb (ea) capacity at ground
BUMPER, FRONT -----Curved, spring type; painted	STEERING GEAR ----- Recirculating-ball type; 26.24:1 ratio; 18-inch dia wheel
CLUTCH -----Diaphragm spring; single disc type; 10 dia; 100.53 sq. in. area; 238 ft lb capacity	TIRES ----- Front, rear and spare; 6.00-16-6pr; 1065 lb (ea) capacity
COLOR, BASIC VEHICLE ----- Juniper Green	TOOLS ----- 2500 lb capacity jack; wheel wrench; jack handle
COOLING SYSTEM ---- Cellular radiator core, 4 lb press. cap; 407 sq.in. frontal area; 16 quart capacity	TOOL BOX (3112 only) ----- 50 x 19 x 2-3/8
DISPATCH BOX - 3102 -----13-7/8 x 4-3/4 x 8-1/4	TRANSMISSION ----- 3 - speed, Synchro-mesh; gearshift control mounted on steering column.
3112 -----13-1/2 x 5-1/2 x 8-1/2	VENTILATOR ----- Top of cowl
DRIVE SYSTEM ----- Hotchkiss	WHEELS ----- 5; 16 x 4-1/2K
ENGINE -----Thriftmaster; 235.5 cu. in. displ.	WINDSHIELD WIPERS - (3112 only)-Dual; cowl-mounted
GROSS HP ----- 112 @ 3700 RPM	
GROSS TORQUE ----- 200 ft lb @ 2000 RPM	
FENDERS ----- Front and rear	
FRAME -----Ladder type with 4 cross members, channel side rails 5-3/4 x 2-1/4 x 9/64; section modulus 2.46 in. <sup>3</sup>	

**OPTIONAL EQUIPMENT**

For model application see Option Section

	Wt	Number		Wt	Number
AIR CLEANER: AC make, oil bath type			GOVERNOR:		
1 pint capacity ----- *	216		Range 2300-3200 RPM ----- *	241	
2 pint capacity ----- *	216		OIL FILTER: AC make;		
BUMPER EQUIPMENT, REAR -----30R	218		1 quart capacity ----- 8F	237	
CHROME EQUIPMENT: Includes Radiator			2 quart capacity ----- 15F	237	
Grille, Front Bumper & Hub Caps ----- *	393		SHOCK ABSORBER SHIELDS, REAR ---- *	211	
CLUTCH, HEAVY DUTY: Diaphragm			SPRINGS REAR:		
spring, single disc type; 11 dia;			Heavy Duty; semi-elliptic; 10-leaf; 1800 lb (ea)		
123.7 sq. in. area; 282 ft lb cap. ----- *	227		capacity at ground ----- 24R	254	
COLORS, VEHICLE, Solid ----- *	234		TIRES, MAXIMUM:		
CRANKCASE VENTILATION: Vac-operated with			Front, rear and spare; 15-6pr;		
filtered air from oil bath air cleaner --- *	217		1500 lb (ea) capacity ----- 42F, 64R	273	
FENDERS, LESS REAR ----- Minus 40R	615		TRANSMISSION:		
GENERATOR: Including voltage and current			3-Speed Heavy Duty ----- 12F, 5R	316	
regulator, and pulley for high output			Automatic 4-Speed ----- 100F, 40R	314	
40 amp ----- 13F	326		4-Speed, Synchro-mesh; power-take-off		
45 amp ----- *	326		opening on left side ----- 53F, 22R	318	
50 amp ----- 13F	326		VACUUM BOOSTER AND FUEL PUMP--- *	340	
55 amp ----- 32F	326		WINDSHIELD WIPERS:		
55 amp, low cut-in ----- 32F	326		Dual, Electric (3112 only) ----- *	320	

\* - Weight is less than 10 pounds

### CHASSIS AND BODY DIMENSIONS

#### Model 3103 Cab Chassis

Seat in rear position  
Adjustment - 3.38

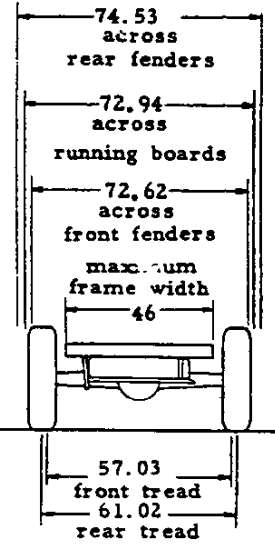
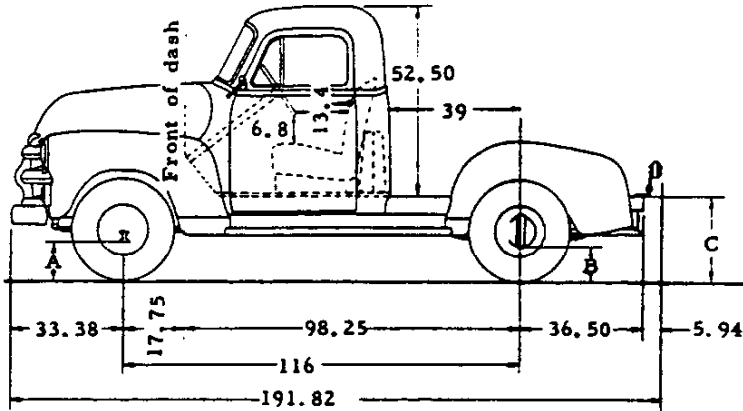

Equipment	Height Without Body and Payload		
	A	B	C
Standard	8.25	8.00	25.75
Minimum for Max GVW	8.25	8.38	26.00

#### Model 3104 Pickup Truck

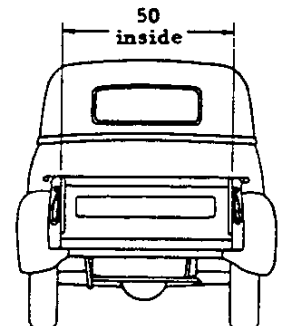
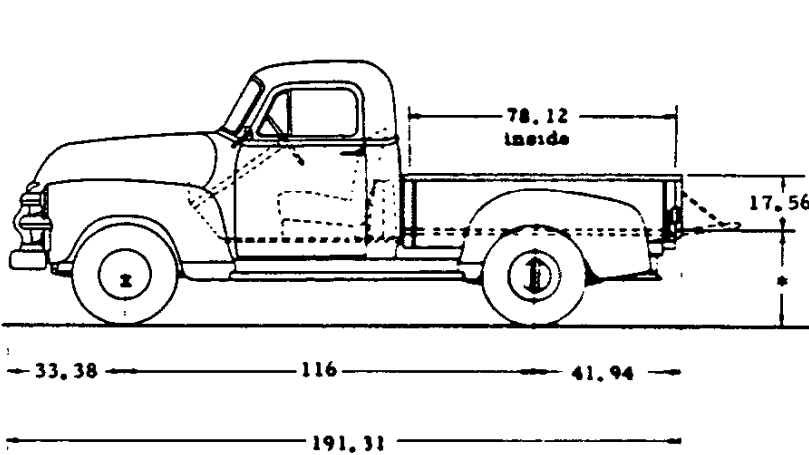

Equipment	*Platform Height		Tires	
	Loaded	Unloaded	Front	Rear
Standard	23.75	27.75	6.00-16-6pr	6.00-16-6pr
Minimum for Max GVW	22.00	28.25	6.00-16-6pr	6.50-16-6pr

### VEHICLE WEIGHTS AND LOAD DISTRIBUTION

MODEL	WITH STANDARD EQUIPMENT						WITH MINIMUM EQUIPMENT FOR MAXIMUM GVW			
	Shipping			Curb			Body and/or Payload	Payload Distribution		Body Length
	Front	Rear	Total	Front	Rear	Total		Front	Rear	
3103 Ⓞ	1780	1070	2850	1850	1140	2990	1800	11%	89%	48
								6%	94%	60
3104 Ⓞ	1780	1335	3115	1850	1405	3255	1500	0%	100%	72
								0%	100%	78

10-29-54

Ⓞ - Estimated weight

**MODEL 3103 LIGHT DUTY CAB CHASSIS  
MODEL 3104 LIGHT DUTY PICKUP TRUCK**

1/2 TON NOMINAL RATING --- 116 WHEELBASE --- 4800 lb MAXIMUM GVW

**STANDARD EQUIPMENT**

AIR CLEANER -----AC make; oil-wetted type	FRAME -----Ladder type with 4-cross members, channel side rails 5-3/4 x 2-1/4 x 9/64; section modulus 2.46 in. <sup>3</sup>
AXLE, FRONT ----- 1-beam type; 2200 lbs capacity	FUEL TANK -----Back of seat in cab; 17-1/2 gal. capacity
AXLE, REAR ---Semi-floating type; 3300 lbs capacity; hypoid gears; 3.9 ratio	GENERATOR ----- 40 amp maximum rate
BATTERY -----15 plate; 100 amp hr capacity	LIGHTS ----- 2 head, 2 parking, and 1 tail and stop
BODY	MIRROR, REAR VIEW -----LH; short fixed bracket
3103-----None	RUNNING BOARDS ----- Full length
3104-----Welded steel box, wood floor, and steel skid strips	SEAT ----- Full width
BRAKES	SHOCK ABSORBERS --- Front and rear; direct double- acting; 1-inch dia piston.
PARKING ----- Foot-operated on rear wheels, 74 sq. in. area	SPARE WHEEL CARRIER -----Underslung at rear
SERVICE ----- Hydraulic type; 4-wheel; 158 sq. in.	SPRINGS, FRONT -- Semi-elliptic; 8-leaf, 38 x 1-3/4; 1000 lb (ea) capacity at ground
FRONT ----- 11 x 2; 84 sq. in. area	SPRINGS, REAR --- Semi-elliptic; 8-leaf, 54 x 1-3/4; 1450 lb (ea) capacity at ground
REAR ----- 11 x 1-3/4; 74 sq. in. area	STEERING GEAR ----- Recirculating-ball type; 26.24 ratio; 18-inch dia wheel
BUMPERS, FRONT ----- Curved, spring type, painted	SUNSHADE -----Adjustable; for driver
CAB -----All-steel; welded; flexibly mounted	TIRES----- Front, rear, and spare; 6.00- 16-6pr; 1065 lb (ea) capacity
CLUTCH ----- Diaphragm spring; single disc type; 10 dia; 100.53 sq. in. area; 238 ft lb capacity	TOOLS ----- 2500 lb capacity jack; jack handle; wheel wrench
COLOR, BASIC VEHICLE ----- Juniper Green	TOOL BOX ----- Under seat; 50 x 19 x 6
COOLING SYSTEM ----- Cellular radiator core; 407 sq. in. frontal area; 4 lb pressure cap; 16 qt capacity	TRANSMISSION ----- 3-Speed, Synchro-mesh; gearshift control mount- ed on steering column
DISPATCH BOX ----- 13-1/2 x 5-1/2 x 8-1/2	VENTILATORS -----Top of cowl and ventipanes
DOME LIGHT ----- Above rear window	WHEELS ----- 5; 16 x 4-1/2K
DRIVE SYSTEM ----- Hotchkiss	WINDSHIELD WIPERS ----- Dual; cowl-mounted
ENGINE -----Thriftmaster; 235.5 cu. in. displ	
GROSS HP -----112 @ 3700 RPM	
GROSS TORQUE ----- 200 ft lb @ 2000 RPM	
FENDERS -----Front and rear	

**OPTIONAL EQUIPMENT**

For model application See Option Section

	Wt	Number		Wt	Number
AIR CLEANER: AC make; oil bath type			GOVERNOR: Range 2300-3200 RPM ----- *		241
1 pint capacity -----*	216		MIRROR, REAR VIEW:		
2 pint capacity -----*	216		RH, Long or short; LH, long ----- *		210
BUMPER EQUIPMENT, REAR ----- 30R	218		OIL FILTER: AC make;		
CHROME EQUIPMENT: Includes Radiator Grille,			1 quart capacity ----- 8F	237	
Front Bumper and Hub Caps -----*	393		2 quart capacity ----- 15F	237	
CLUTCH, HEAVY DUTY: Diaphragm			SEAT EQUIPMENT: Unison -----*		264
spring; single disc type; 11 dia;			SHOCK ABSORBER SHIELDS, REAR -----*		211
123.7 sq. in. area; 282 ft lb cap. ----- *	227		SIDE DOOR AND WHEEL CARRIER LOCK-*		395
COLORS, VEHICLE. Solid -----*	234		SPRINGS, REAR:		
Two-tone -----*	438		Heavy duty; semi-elliptic; 10-leaf; 1800 lb (ea) capacity at ground ----- 24R	254	
CORNER WINDOWS, CAB: Clear or tinted--*	387		TIRES, MAXIMUM:		
CRANKCASE VENTILATION: Vac-operated with			Front, rear, and spare; 15-6pr;		
filtered air from oil bath air cleaner ----*	217		1500 lb (ea) capacity ----- 42F, 64R	273	
DELUXE EQUIPMENT -----*	430		TRANSMISSION:		
FENDERS, LESS REAR (3103 only) --- Minus 40R	615		3-Speed heavy duty -----12F, 5R	316	
GENERATOR: With voltage and current			Automatic 4-Speed ----- 100F, 40R	314	
regulator, and pulley for high output			4-Speed, Synchro-mesh; Power take- off opening on left side ----- 53F, 22R	318	
40 amp -----13F	326		VACUUM BOOSTER AND FUEL PUMP -- *		340
45 amp ----- *	326		WHEEL CARRIER EQUIPMENT (3104 only):		
50 amp -----13F	326		Side mounted -----*		341
55 amp ----- 32F	326		WINDSHIELD WIPERS: Dual, Electric --- *		320
55 amp, low cut-in -----32F	326				
GLASS EQUIPMENT, BODY: Tinted ----- *	399				

\*-Weight is less than 10 pounds

10-29-54

**CHEVROLET 1955 SPECIFICATIONS—TRUCK**

**MODELS 3103 AND 3104 DATA - 67**



### CHASSIS AND BODY DIMENSIONS

**Model 3105 Panel Truck**

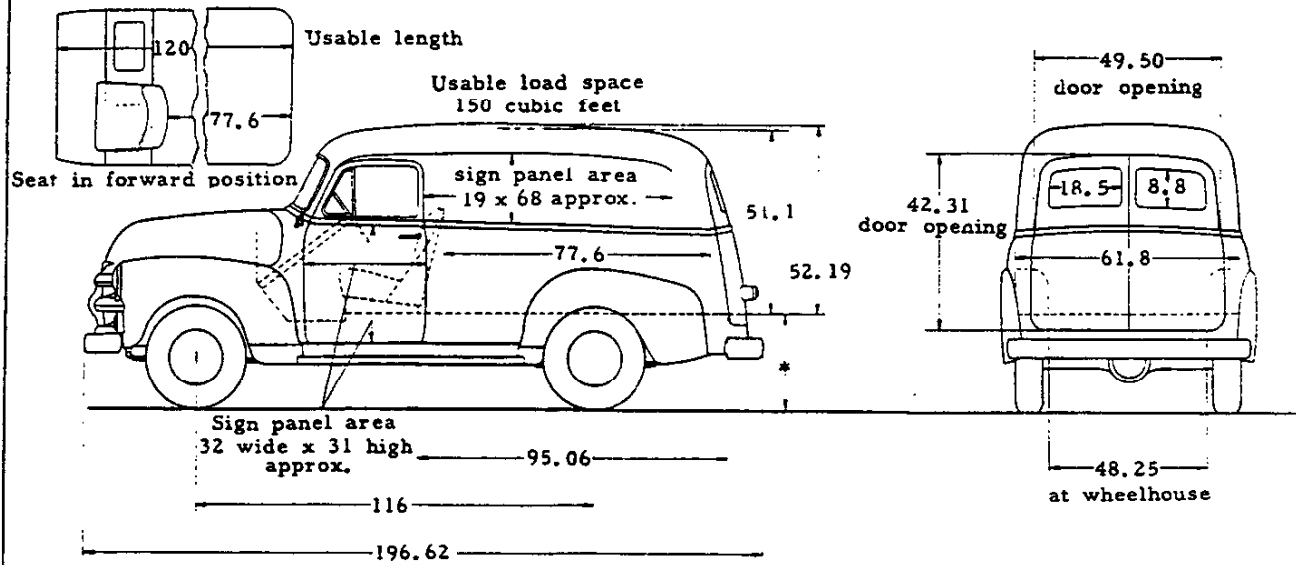

Equipment	*Platform Height		Tires	
	Loaded	Unloaded	Front	Rear
Standard	25.25	28.00	6.00-16-6pr	6.00-16-6pr
Minimum for Max GVW	23.25	28.50	6.00-16-6pr	6.50-16-6pr

**Model 3107 Canopy Express Truck**

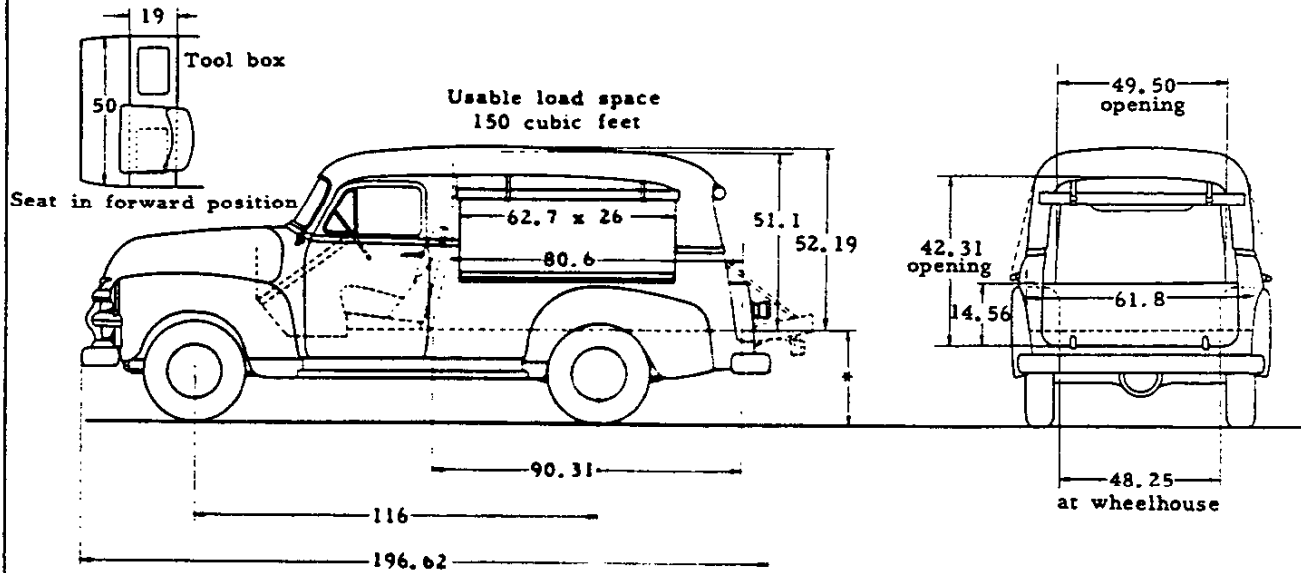

Equipment	*Platform Height		Tires	
	Loaded	Unloaded	Front	Rear
Standard	25.25	28.25	6.00-16-6pr	6.00-16-6pr
Minimum for Max GVW	23.25	28.75	6.00-16-6pr	6.50-16-6pr

### VEHICLE WEIGHTS AND LOAD DISTRIBUTION

MODEL	WITH STANDARD EQUIPMENT						WITH MINIMUM EQUIPMENT FOR MAXIMUM GVW		
	Shipping			Curb			Payload	Payload Distribution	
	Front	Rear	Total	Front	Rear	Total		Front	Rear
3105 Ⓞ	1725	1605	3330	1775	1685	3460	1300	5%	95%
3107 Ⓞ	1745	1555	3300	1795	1635	3430	1350	4%	96%

Ⓞ - Estimated Weight

10-29-54

**68 - MODELS 3105 AND 3107 DATA**

**CHEVROLET 1955 SPECIFICATIONS—TRUCK**

**MODEL 3105 LIGHT DUTY PANEL TRUCK  
MODEL 3107 LIGHT DUTY CANOPY EXPRESS TRUCK**

1/2-TON NOMINAL RATING --- 116 WHEELBASE --- 4800 lb MAXIMUM GVW

**STANDARD EQUIPMENT**

AIR CLEANER ----- AC make; oil-wetted type	FENDERS ----- Front and rear
AXLE, FRONT ----- I-beam type; 2200 lb capacity	FRAME ----- Ladder type with 4 cross members, channel side rails 5-3/4 x 2-1/4 x 9/64; section modulus 2.46 in. <sup>3</sup>
AXLE, REAR ----- Semi-floating; 3300 lb capacity; hypoid gears; 3.9 ratio	FUEL TANK ----- Inside of frame on right side; 16 gallon capacity
BATTERY ----- 15 plate; 100 amp hr capacity	GENERATOR ----- 40 amp maximum rate
BODY	LIGHTS ----- 2 head, 2 parking, and 1 tail and stop
PANEL ----- All-steel panel with plywood floor and steel skid strips. Two rear doors for full width opening at rear.	MIRROR, REAR VIEW ----- LH; short fixed bracket
CANOPY ----- All-steel with plywood floor and steel skid strips. Weather-proof curtains for load compartment, side and rear openings. Tail gate in rear. Sheet metal partition with window between driver compartment and load space.	RIDE STABILIZER ----- Frame to front axle (3105 only)
EXPRESS	RUNNING BOARDS ----- Full length
BRAKES	SEAT ----- Bucket type; driver only
PARKING ----- Foot-operated on rear wheels; 74 sq. in. area.	SHOCK ABSORBERS ----- Front and rear; direct double-acting; 1-inch dia piston
SERVICE ----- Hydraulic type; 4-wheel; 158 sq. in. FRONT ----- 11 x 2; 84 sq. in. area REAR ----- 11 x 1-3/4; 74 sq. in. area	SPARE WHEEL CARRIER ----- Underslung at rear
BUMPERS ----- Curved, spring type; painted	SPRINGS
CLUTCH --- Diaphragm spring, single disc type; 10 dia; 100.53 sq. in. area; 238 ft lb capacity	FRONT ----- Semi-elliptic; 8-leaf, 38 x 1-3/4 1000 lb (ea) capacity at ground
COLOR, BASIC VEHICLE ----- Juniper Green	REAR ----- Semi-elliptic; 8-leaf, 54 x 1-3/4 1450 lb (ea) capacity at ground
COOLING SYSTEM ----- Cellular radiator core; 407 sq. in. frontal area; 4 lb pressure cap; 16 qt capacity	STEERING GEAR ----- Recirculating-ball type; 26.24 ratio; 18-inch dia wheel
DISPATCH BOX ----- 13-1/2 x 5-1/2 x 8-1/2	SUNSHADE ----- Adjustable; for driver
DOME LIGHT ----- Above driver on centerline of car	TIRES ----- Front, rear, and spare; 6.00-16-6 pr; 1065 lb (ea) capacity
DRIVE SYSTEM ----- Hotchkiss	TOOLS ----- 2500 lb capacity jack; jack handle; wheel wrench
ENGINE ----- Thriftmaster; 235.5 cu. in. displacement	TOOL BOX ----- Under seat; 50 x 19 x 2-3/8
GROSS HP ----- 112 @ 3700 RPM	TRANSMISSION ----- 3-Speed, Synchro-mesh; gearshift control mounted on steering column.
GROSS TORQUE ----- 200 ft lb @ 2000 RPM	VENTILATORS ----- Top of cowl and ventipanes
	WHEELS ----- 5; 16 x 4-1/2K
	WINDSHIELD WIPERS ----- Dual; cowl mounted

**OPTIONAL EQUIPMENT**

For model application see Option Section

	Wt	Number		Wt	Number
AIR CLEANER: AC make; oil bath type			LAMPS, TAIL AND STOP: Dual mounted	*	249
1 pint capacity ----- *	216		MIRROR, REAR VIEW: Short, RH ----- *		210
2 pint capacity ----- *	216		OIL FILTER: AC make;		
CHROME EQUIPMENT: Includes Radiator Grille, Front & Rear Bumpers & Hub caps ----- *	393		1 quart capacity ----- 8F		237
CLUTCH, HEAVY DUTY: Diaphragm spring, single disc type; 11 dia; 123.7 sq. in. area; 282 ft lb capacity -- *	227		2 quart capacity ----- 15F		237
COLORS, VEHICLE, Solid ----- *	234		SEAT, AUXILIARY:		
Two-tone (3105 only) ----- *	439		Imitation leather ----- 24F, 24R		263
CRANKCASE VENTILATION: Vac-operated with filtered air from oil bath air cleaner ----- *	217		SHOCK ABSORBER SHIELDS, REAR ----- *		211
DELUXE EQUIPMENT (3105 only) ----- *	430		SIDE DOOR KEY LOCK, LH ----- *		395
GENERATOR: Including voltage and current regulator, and pulley for high output			SPRINGS, REAR:		
40 amp ----- 13F	326		Heavy duty; semi-elliptic; 10-leaf; 1800 lb (ea) capacity at ground ----- 24R		254
45 amp ----- *	326		TIRES, MAXIMUM: Front and rear, and spare, 15-6pr; 1500 lb (ea) capacity ----- 42F, 64R		273
50 amp ----- 13F	326		TRANSMISSION:		
55 amp ----- 32F	326		3-Speed Heavy Duty ----- 12F, 5R		316
55 amp, low cut-in ----- 32F	326		Automatic 4-Speed ----- 100F, 40R		314
GLASS EQUIPMENT, BODY: : Tinted ----- *	399		4-Speed, Synchro-mesh; Power take-off opening on left side ----- 53F, 22R		318
GOVERNOR: Range 2300-3200 RPM ----- *	241		VACUUM BOOSTER AND FUEL PUMP --- *		340
			WINDSHIELD WIPERS:		
			Dual, Electric ----- *		320

\* - Weight is less than 10 pounds

10-29-54

**CHASSIS AND BODY DIMENSIONS**

**Model 3106 Suburban Carryall**

Auxiliary seat moves forward 10 to provide access to center and rear seats.

Center and rear seats removable rear seat adaptable to center seat position.

Leg room  
 Front seat 42.38  
 Center seat 37.75  
 Rear seat 38.25

Seat adjustment - 3

Equipment	*Platform Height		Tires	
	Loaded	Unloaded	Front	Rear
Standard	25.25	26.88	6.00-16-6pr	6.00-16-6pr
Minimum for Max GVW	23.25	27.25	6.00-16-6pr	6.50-16-6pr

**Model 3116 Suburban Carryall**

Auxiliary seat moves forward 10 to provide access to center and rear seats.

Center and rear seats removable rear seat adaptable to center seat position.

Leg room  
 Front seat 42.38  
 Center seat 37.75  
 Rear Seat 38.25

Seat adjustment - 3

Equipment	*Platform Height		Tires	
	Loaded	Unloaded	Front	Rear
Standard	25.25	26.88	6.00-16-6pr	6.00-16-6pr
Minimum for Max GVW	23.25	27.25	6.00-16-6pr	6.50-16-6pr

**VEHICLE WEIGHTS AND LOAD DISTRIBUTION**

MODEL	WITH STANDARD EQUIPMENT						WITH MINIMUM EQUIPMENT FOR MAXIMUM GVW			
	Shipping			Curb			Payload	Payload Distribution		
	Front	Rear	Total	Front	Rear	Total		Front	Rear	
3106 ⓪	1755	1855	3610	1805	1935	3740	1050	3%	97%	
3116 ⓪	1750	1860	3610	1800	1940	3740	1050	3%	97%	

10-29-54

⓪ - Estimated weight

**70-MODELS 3106 AND 3116 DATA**

**CHEVROLET 1955 SPECIFICATIONS—TRUCK**

**MODEL 3106 SUBURBAN CARRYALL WITH REAR DOORS  
MODEL 3116 SUBURBAN CARRYALL WITH TAIL AND LIFT GATE**

1/2 TON NOMINAL RATING --- 116 WHEELBASE --- 4800 lb MAXIMUM GVW

**STANDARD EQUIPMENT**

<b>AIR CLEANER</b> ----- AC make; oil-wetted type	<b>FRAME</b> ----- Ladder type with 4 cross members;
<b>AXLE, FRONT</b> ----- 1-beam type; 2200 lb capacity	channel side rails 5-3/4 x 2-1/4 x 9/64;
<b>AXLE, REAR</b> --- Semi-floating type; 3300 lb capacity;	section modulus 2.46 in <sup>3</sup>
hypoid gears; 3.9 ratio	<b>FUEL TANK</b> ----- Inside of frame on right side;
<b>BATTERY</b> ----- 15 plate; 100 amp hr capacity	16 gallon capacity
<b>BODY</b> ----- All-steel, single unit, eight passenger	<b>GENERATOR</b> ----- 40 amp maximum rate
body with removable rear and center seats	<b>LIGHTS</b> ----- 2 Head, 2 parking, and 1 tail and stop
and linoleum covered plywood floor.	<b>MIRROR, REAR VIEW</b> ----- LH; Short fixed bracket
Model 3106 has panel type rear doors and	<b>RIDE STABILIZER</b> ----- Frame to front axle
Model 3116 has a tail gate and lift type	<b>RUNNING BOARDS</b> ----- Full length
doors.	<b>SEATS</b> --- Front, 3-pass; center, 2-pass rear; 3-pass
<b>BRAKES</b>	<b>SHOCK ABSORBERS</b> --- Front and rear; direct double-
<b>PARKING</b> ----- Foot-operated on rear wheels;	acting; 1-inch dia piston
74 sq. in. area	<b>SPARE WHEEL CARRIER</b> ----- Underslung at rear
<b>SERVICE</b> ----- Hydraulic type; 4-wheel; 158 sq. in.	<b>SPRINGS</b>
<b>FRONT</b> ----- 11 x 2; 84 sq. in. area	<b>FRONT</b> ----- Semi-elliptic, 8-leaf; 38 x 1-3/4;
<b>REAR</b> ----- 11 x 1-3/4; 74 sq. in. area	1000 lb (ea) capacity at ground
<b>BUMPERS</b> ----- Curved, spring type; painted	<b>REAR</b> ----- Semi-elliptic, 8-leaf; 54 x 1-3/4;
<b>CLUTCH</b> ----- Diaphragm spring single disc	1450 lb (ea) capacity at ground
type; 10 dia, 100.53 sq. in.	<b>STEERING GEAR</b> ----- Recirculating-ball type; 26.24
area; 238 ft lb capacity	ratio; 18 dia wheel
<b>COLOR, BASIC VEHICLE</b> ----- Juniper Green	<b>SUNSHADE (LH only)</b> ----- One, adjustable
<b>COOLING SYSTEM</b> ----- Cellular radiator core, 4 lb	<b>TIRES</b> ----- Front, Rear, and Spare; 6.00-16-6pr;
press. cap; 407 sq. in. frontal	1065 lb (ea) capacity
area; 16 quart capacity	<b>TOOLS</b> --- 2500 lb cap. jack; wheel handle; wheel wrench
<b>DISPATCH BOX</b> ----- 13-1/2 x 5-1/2 x 8-1/2	<b>TOOL BOX</b> ----- Under seat; 36 x 19 x 2-3/8
<b>DOME LIGHT</b> ----- Above driver on centerline of car	<b>TRANSMISSION</b> ----- 3-Speed, Synchro-mesh;
<b>DRIVE SYSTEM</b> ----- Hotchkiss	steering column-mounted
<b>ENGINE</b> ----- Thriftmaster 235.5 cu. in. displ	gearshift control
<b>GROSS HP</b> ----- 112 @ 3700 RPM	<b>VENTILATORS</b> ----- Top of cowl and ventipanes
<b>GROSS TORQUE</b> ----- 200 ft lb @ 2000 RPM	<b>WHEELS</b> ----- 5; 16 x 4-1/2K
<b>FENDERS</b> ----- Front and Rear	<b>WINDSHIELD WIPERS</b> ----- Dual; cowl-mounted

**OPTIONAL EQUIPMENT**

For model application see Option Section

	Wt	Number		Wt	Number
<b>AIR CLEANER: AC make; oil bath type</b>			<b>LAMPS, DUAL TAIL AND STOP</b> ----- *		249
1 pint capacity ----- *	216		<b>MIRROR, REAR VIEW: Short RH</b> ----- *		210
2 pint capacity ----- *	216		<b>OIL FILTER: AC make;</b>		
<b>CHROME EQUIPMENT: Includes Radiator Grille</b>			1 quart capacity ----- *		237
Front & Rear Bumpers & Hubs Caps ----- *	393		2 quart capacity ----- 12F		237
<b>CLUTCH, HEAVY DUTY: Diaphragm</b>			<b>SHOCK ABSORBER SHIELDS, REAR</b> --- *		211
spring, single disc type;			<b>SIDE DOOR KEY LOCK, LH</b> ----- *		395
11 dia; 123.7 sq. in. area			<b>SPRINGS, REAR:</b>		
282 ft lb capacity ----- *	227		Heavy duty; semi-elliptic; 10-leaf; 1800 lb (ea)		
<b>COLORS, VEHICLE, Solid</b> ----- *	234		capacity at ground ----- 24R		254
<b>CRANKCASE VENTILATION: Vac-operated with</b>			<b>TIRES, MAXIMUM</b>		
filtered air from oil bath air cleaner --- *	217		Front, rear and spare; 15-6pr;		
<b>GENERATOR: Including voltage and current</b>			1500 lb (ea) capacity ----- 42F, 64R		273
regulator, and pulley for high output			<b>TRANSMISSION:</b>		
40 amp --- ----- 13F	326		3-Speed Heavy Duty ----- 12F, 5R		316
45 amp ----- *	326		Automatic 4-speed ----- 100F, 40R		314
50 amp ----- 13F	326		4-Speed, synchro-mesh; Power take-off		
55 amp ----- 32F	326		opening on left side ----- 53F, 22R		318
55 amp, low cut-in ----- 32F	326		<b>VACUUM BOOSTER AND FUEL PUMP</b> - *		340
<b>GLASS EQUIPMENT, BODY: Tinted</b> ----- *	399		<b>WINDSHIELD WIPERS:</b>		
<b>GOVERNOR:</b>			Dual, Electric ----- *		320
Range 2300-3200 RPM ----- *	241				

\* - Weight is less than 10 pounds

10-29-54

**CHEVROLET 1955 SPECIFICATIONS—TRUCK**

**MODELS 3106 AND 3116 DATA- 71**

CHASSIS AND BODY DIMENSIONS

Model 3602 Flat Face Cowl Chassis  
 Model 3612 Windshield Cowl Chassis

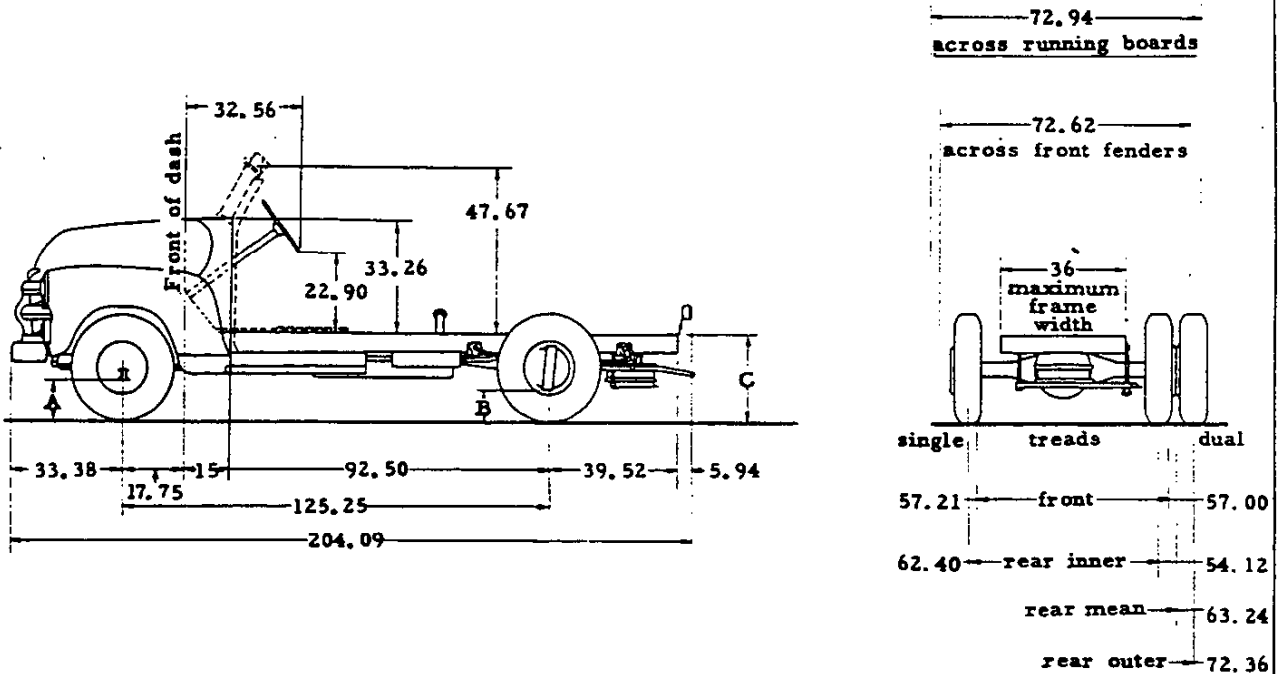

Equipment	Height Without Body and Payload		
	A	B	C
Standard	8.91	7.68	27.75
Minimum for Max GVW	8.84	7.55	28.14

To determine loaded and unloaded heights, body specifications must be known. Minimum tire equipment for max. GVW is 7.00-17-6 front and 7.50-17-8pr rear.

VEHICLE WEIGHTS AND LOAD DISTRIBUTION

MODEL	WITH STANDARD EQUIPMENT						WITH MINIMUM EQUIPMENT FOR MAXIMUM GVW			
	Shipping			Curb			Body and Payload	Payload Distribution		Body Length
	Front	Rear	Total	Front	Rear	Total		Front	Rear	
3602	1675	1010	2685	1740	1115	2855	3950	Determined by style, length and weight of body.		
3612 Ⓞ	1720	1060	2780	1785	1165	2950	3850			

Ⓞ - Estimated Weight

10-29-54

72-MODELS 3602 AND 3612 DATA

CHEVROLET 1955 SPECIFICATIONS—TRUCK

MODEL 3602 MEDIUM DUTY FLAT FACE COWL CHASSIS  
MODEL 3612 MEDIUM DUTY WINDSHIELD COWL CHASSIS

3/4 TON NOMINAL RATING --- 125-1/4 WHEELBASE --- 6900 MAXIMUM GVW

STANDARD EQUIPMENT

AIR CLEANER -----	AC make; oil-wetted type	FUEL TANK -----	Inside of frame on right side
AXLE, FRONT -----	I-beam type; 2500 lb capacity		16 gallon capacity
AXLE, REAR ---	Full-floating type; 5000 lb capacity;	GENERATOR -----	40 amp maximum rate
	Hypoid gears; 4.57 ratio	LIGHTS -----	2 head, 2 parking, and
BATTERY -----	15 plate; 100 amp hr capacity		1 tail and stop
BRAKES		RUNNING BOARDS -----	Short
PARKING -----	Foot-operated on rear wheels;	SEAT RISER -----	3612 only
	93 sq. in. area	SHOCK ABSORBERS -----	Front and rear; direct
SERVICE ----	Hydraulic type; 4-wheel; 186 sq. in.		double-acting 1-inch
FRONT -----	12 x 2; 93 sq. in. area		dia. piston
REAR -----	12 x 2; 93 sq. in. area	SPARE WHEEL CARRIER -----	Underslung at rear
BUMPER, FRONT -----	Curved spring type;	SPRINGS	
	front	FRONT -----	Semi-elliptic; 8-leaf, 38 x 1-3/4;
CLUTCH--	Diaphragm spring; single disc type; 10 dia;		1150 lb (ea) capacity at ground
	100.53 sq. in. area; 238 ft lb capacity	REAR ----	Semi-elliptic; 2-stage; 7-leaf, 46 x 2;
COLOR, BASIC VEHICLE -----	Juniper Green		2000 lb (ea) capacity at ground
COOLING SYSTEM ---	Cellular radiator core. 4 lb	STEERING GEAR -----	Recirculating-ball type; 26.24
	press. cap; 407 sq. in. frontal		ratio; 18-inch dia wheel
	area; 16 quart capacity	TIRES ---	Front and rear; 15-6pr; 1500 lb (ea) cap.
DISPATCH BOX-3602 -----	13-7/8 x 4-3/4 x 8-1/4	TOOLS -----	2500 lb capacity jack; jack handle;
3612 -----	13-1/2 x 5-1/2 x 8-1/2		tire changing iron; wheel wrench;
DRIVE SYSTEM -----	Hotchkiss	TOOL BOX (3612 only) -----	50 x 19 x 2-3/8
ENGINE -----	Thriftmaster; 235.5 cu. in. displ	TRANSMISSION -----	3-Speed, Synchro-mesh,
GROSS HP -----	112 @ 3700 RPM		gearshift control mount-
GROSS TORQUE -----	200 ft lb @ 2000 RPM		ed on steering column
FENDERS -----	Front only	VENTILATOR -----	Top of cowl
FRAME ----	Ladder type with 5 cross members,	WHEELS -----	5; 15 x 5.50 F
	channel side rails 5-27/32 x 2-1/4 x 3/16;	WINDSHIELD WIPERS:	
	section modulus 3.25 in <sup>3</sup>	3612 only -----	Dual; cowl mounted

OPTIONAL EQUIPMENT

For model application see Option Section

	Wt	Number	Wt	Number
AIR CLEANER: AC make; oil bath type				
1 pint capacity -----	*	216	RADIATOR, HEAVY DUTY: 17 qt cap. -----	* 256
2 pint capacity -----	*	216	RUNNING BOARDS (long)	
AXLE, REAR: Single-speed; full-floating,			AND REAR FENDERS -----	72F 207
5.14 ratio; 5000 lb capacity -----	*	208	SHOCK ABSORBER SHIELDS, REAR -----	* 211
BUMPER EQUIPMENT, REAR -----	32R	218	SPRINGS, REAR	
CHROME EQUIPMENT: Includes Radiator			Included in tire RPOs 272 and 282;	
Grille, Front Bumper & Hub Caps -----	*	393	8-leaf; two-stage; 2500 lb (ea)	
CLUTCH, HEAVY DUTY -----	*	227	capacity at ground	
COLORS, VEHICLE, Solid -----	*	234	TIRES, MAXIMUM	
CRANKCASE VENTILATION: Vac-operated with			Front and single rear;	
filtered air from oil bath air cleaner ---	*	217	7.50-17-8pr; 2100 lb (ea) capacity;	
GENERATOR: Including voltage and current			(Spring weight included) -----	45F, 71R 272
regulator, and pulley for high output			Front and dual rear;	
40 amp -----	13F	326	6.50-16-6pr; 1215 lb (ea) capacity;	
45 amp -----	*	326	(Spring weight included) -----	25F, 165R 282
50 amp -----	13F	326	TRANSMISSION:	
55 amp -----	32F	326	3-Speed Heavy Duty -----	13F, 4R 316
55 amp, low cut-in -----	32F	326	Automatic 4-Speed	
GOVERNOR:			without oil cooler -----	110F, 30R 314
Range 2300-3200 RPM -----	*	241	4-Speed, Synchro-mesh; Power take-off	
OIL FILTER: AC make			opening on left side -----	54F, 21R 318
1 quart capacity -----	8F	237	VACUUM BOOSTER AND FUEL PUMP ---	* 340
2 quart capacity -----	15F	237	WINDSHIELD WIPERS:	
			Dual, Electric (3612 only) -----	* 320

\*-Weight is less than 10 pounds

10-29-54

CHASSIS AND BODY DIMENSIONS

Model 3603 Cab Chassis

Seat in rear position  
Adjustment - 3.38

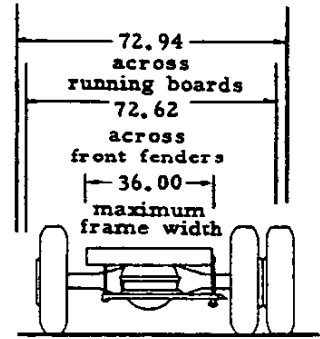
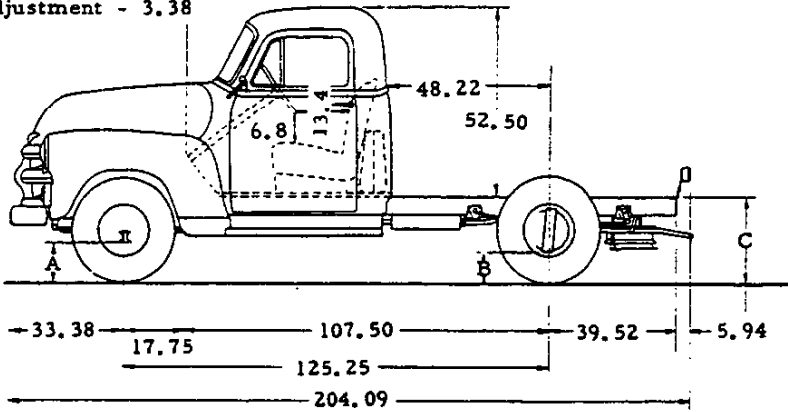

Single	Treads	Dual
57.21	front	57.00
62.40	rear inner	54.12
	rear mean	63.24
	rear outer	72.36

Equipment	Height Without Body and Payload		
	A	B	C
Standard	8.83	7.63	27.77
Minimum for Max GVW	8.75	7.50	27.75

To determine loaded and unloaded heights, body specifications must be known. Minimum tire equipment for Max GVW is 7.00-17-6 front and 7.50-17-8 rear.

Model 3604 Pickup Truck

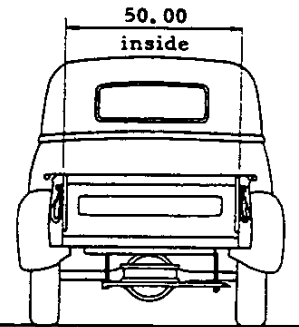
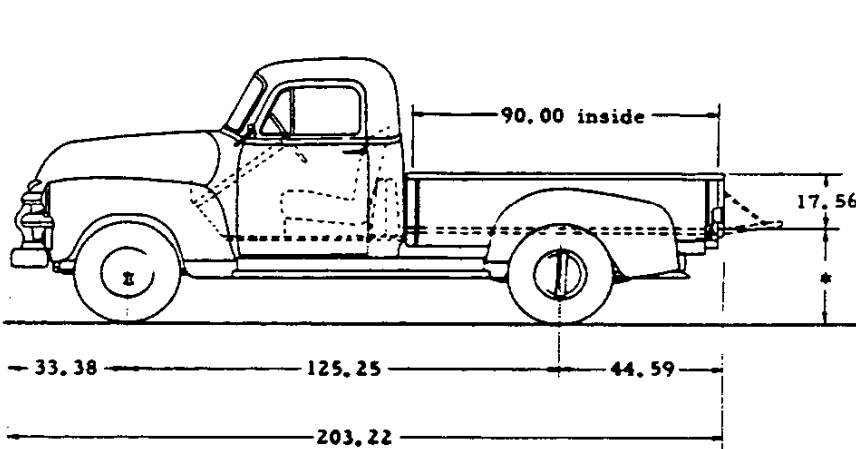

Equipment	*Platform Height		Tires	
	Loaded	Unloaded	Front	Rear
Standard	26.31	30.12	15-6pr	15-6pr
Minimum for Max GVW	28.35	32.11	7.00-17-6pr	7.50-17-8pr

VEHICLE WEIGHTS AND LOAD DISTRIBUTION

MODEL	WITH STANDARD EQUIPMENT						WITH MINIMUM EQUIPMENT FOR MAXIMUM GVW			
	Shipping			Curb			Body and/or Payload	Payload Distribution		Body Length
	Front	Rear	Total	Front	Rear	Total		Front	Rear	
3603	1925	1210	3135	2000	1315	3315	3500	8%	92%	72
								6%	94%	78
								3%	97%	84
								1%	99%	90
3604	1940	1585	3525	2015	1690	3705	3100	2%	98%	90

10-29-54

74-MODELS 3603 AND 3604 DATA

CHEVROLET 1955 SPECIFICATIONS—TRUCK

**MODEL 3603 MEDIUM DUTY CAB CHASSIS  
MODEL 3604 MEDIUM DUTY PICKUP TRUCK**

3/4 TON NOMINAL RATING --- 125-1/4 WHEELBASE --- 6900 lb MAXIMUM GVW

**STANDARD EQUIPMENT**

AIR CLEANER ----- AC make; oil-wetted type	FRAME ---- Ladder type with 5 cross members, channel side rails 5-27/32 x 2-1/4 x 3/16; section modulus 3.25 in <sup>3</sup>
AXLE, FRONT ----- 1-beam type; 2500 lb capacity	FUEL TANK ----- Back of seat in cab; 17-1/2 gals cap.
AXLE, REAR ----- Full floating type; 5000 lb capacity; hypoid gears; 4.57 ratio	GENERATOR ----- 40 amp maximum rate
BATTERY ----- 15 plate; 100 amp hr capacity	LIGHTS ----- 2 head, 2 parking, and 1 tail and stop
BODY	MIRROR, REAR VIEW ---- 3603 LH long adj bracket; 3604 LH short fixed bracket
3604 ----- Welded steel box, wood floor, and steel skid strips.	RUNNING BOARDS ----- 3604 Full length 3603 Short
BRAKES	SEAT ----- Full width
PARKING ----- Foot-operated on rear wheels; 93 sq. in. area	SHOCK ABSORBERS ---- Front and rear; direct double acting 1-inch dia. piston
SERVICE ----- Hydraulic type; 4-wheel; 186 sq. in.	SPARE WHEEL CARRIER ----- Underslung at rear
FRONT ----- 12 x 2; 93 sq. in. area	SPRINGS ----- Semi-elliptic
REAR ----- 12 x 2; 93 sq. in. area	Front-8-leaf, 38 x 1-3/4; 1150 lb (ea) cap. at ground
BUMPER, FRONT ----- Curved, spring type; painted	Rear ----- Two-stage; 7-leaf, 46 x 2; 2000 lb (ea) capacity at ground
CAB ----- All-steel; welded; flexibly mounted	STEERING GEAR ----- Recirculating-ball type; 26.24 ratio; 18-inch dia. wheel
CLUTCH -- Diaphragm spring; single disc type; 10 dia; 100.53 sq. in. area; 238 ft lb capacity	SUNSHADE ----- Adjustable; for driver
COLOR, BASIC VEHICLE ----- Juniper Green	TIRES ----- Front and Rear; 15-6pr; 1500 lb (ea) cap.
COOLING SYSTEM---- Cellular radiator core, 4 lb press. cap; 407 sq. in. frontal area; 16 quart capacity	TOOLS ----- 2500 lb capacity jack; jack handle; tire changing iron; wheel wrench
DISPATCH BOX ----- 13-1/2 x 5-1/2 x 8-1/2	TOOL BOX ----- Under seat; 50 x 19 x 6
DOME LIGHT ----- Above rear window	TRANSMISSION ---- 3-Speed, Synchro-mesh; gearshift control mounted on steering column
DRIVE SYSTEM ----- Hotchkiss	VENTILATORS ----- Top of cowl and ventipanes
ENGINE ----- Thriftmaster; 235.5 cu. in. displ	WHEELS ----- 5; 15 x 5.50F
GROSS HP ----- 112 @ 3700 RPM	WINDSHIELD WIPERS ----- Dual; cowl-mounted
GROSS TORQUE ----- 200 ft lb @ 2000 RPM	
FENDERS ----- 3604 Front and Rear; 3603 Front only	

**OPTIONAL EQUIPMENT**

For model application see Option Section

	Wt	Number		Wt	Number
AIR CLEANER: AC make; oil bath type			RADIATOR, HEAVY DUTY:		
1 pint capacity ----- *	216		17 quart capacity ----- *	256	
2 pint capacity ----- *	216		RUNNING BOARDS (long) AND REAR		
AXLE, REAR: Single-Speed; full-floating:			FENDERS (3603 only) ----- 72R	207	
5.14 ratio; 5000 lb capacity ----- *	208		SEAT EQUIPMENT: Unison ----- *	264	
BUMPER EQUIPMENT, REAR ----- 32R	218		SHOCK ABSORBER SHIELDS, REAR ---- *	211	
CHROME EQUIPMENT: Includes Radiator			SIDE DOOR and WHEEL CARRIER LOCK - *	395	
Grille, Front Bumper & Hub Caps ----- *	393		SPARE WHEEL CARRIER:		
CLUTCH, HEAVY DUTY ----- *	227		Side mounted (3604 only) ----- *	342	
COLORS, VEHICLE, Solid ----- *	234		SPRINGS, REAR:		
Two-tone ----- *	438		Included in tire RPOs 272 and 282;		
CORNER WINDOWS, CAB: Clear or tinted - *	387		8-leaf; two-stage; 2500 lb (ea) capacity at ground		
CRANKCASE VENTILATION: Vac-operated with filtered air from oil bath air cleaner----- *	217		TIRES, MAXIMUM:		
DELUXE EQUIPMENT ----- *	430		Front and single rear;		
GENERATOR: Including voltage and current regulator, and pulley for high output			7.50-17-8pr; 2100 lb (ea) capacity (Spring weight included) ----- 45F, 71R	272	
40 amp ----- 13F	326		Front and dual rear (3603 only)		
45 amp ----- *	326		6.50-16-6pr; 1215 lb (ea) capacity (Spring weight included) ----- 25F, 165R	282	
50 amp ----- 13F	326		TRANSMISSION:		
55 amp ----- 32F	326		3-Speed Heavy Duty ----- 13F, 4R	316	
55 amp, low cut-in ----- 32F	326		Automatic 4-Speed		
GLASS EQUIPMENT, BODY: Tinted ----- *	399		without oil cooler ----- 110F, 30R	314	
GOVERNOR: Range 2300-3200 RPM ----- *	241		4-Speed, Synchro-mesh; Power-take-off opening on left side ----- 53F, 21R	318	
MIRROR, REAR VIEW: 3603, long RH, short RH or LH; 3604, long RH or LH, short RH -- *	210		VACUUM BOOSTER AND FUEL PUMP --- *	340	
OIL FILTER: AC make			WINDSHIELD WIPERS:		
1 quart capacity ----- 8F	237		Dual, Electric ----- *	320	
2 quart capacity ----- 15 F	237				

\* - Weight is less than 10 pounds

10-29-54

**CHEVROLET 1955 SPECIFICATIONS—TRUCK**

**MODELS 3603 AND 3604 DATA-75**



CHASSIS AND BODY DIMENSIONS

Model 3608 Platform Truck

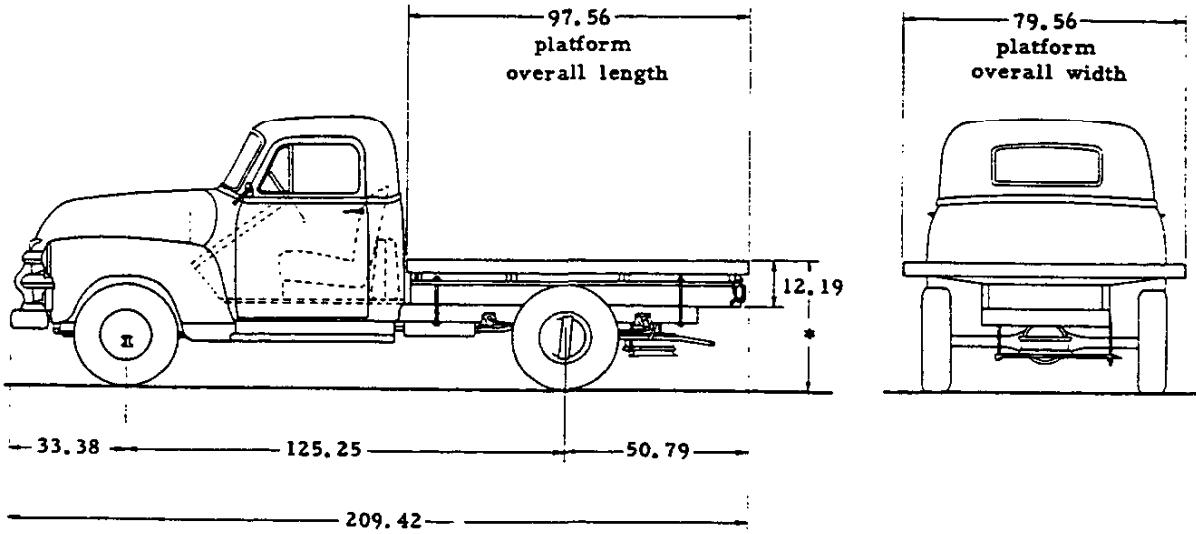

Equipment	*Platform Height		Tires	
	Loaded	Unloaded	Front	Rear
Standard	35.34	39.18	15-6pr	15-6pr
Minimum for Max GVW	35.75	39.50	6.50-16-6pr	6.50-16-6pr dual

Model 3609 Stake Truck

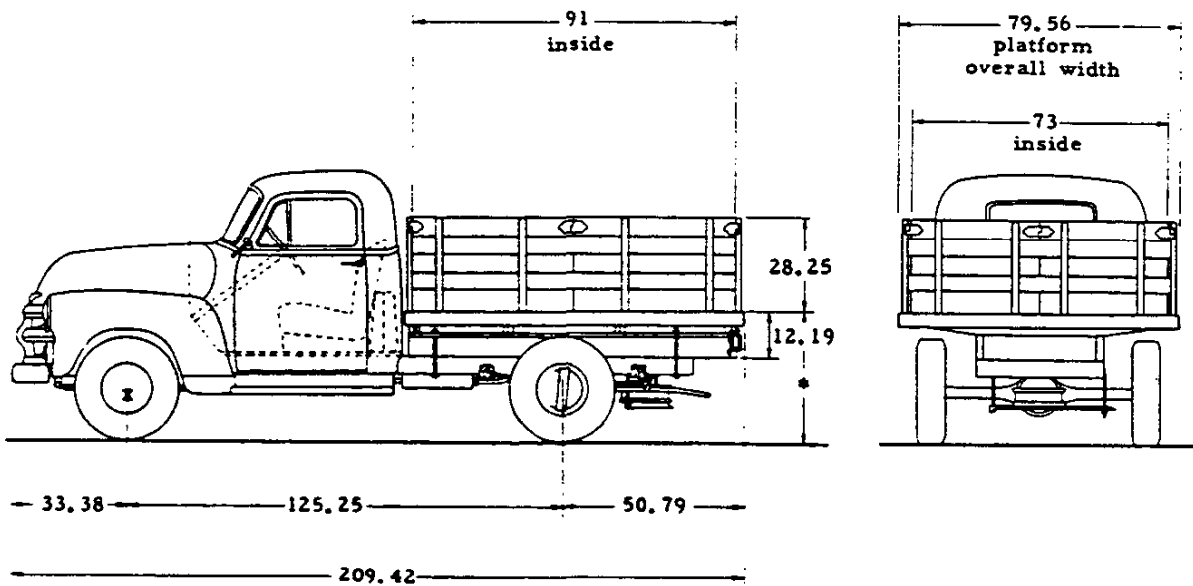

Equipment	*Platform Height		Tires	
	Loaded	Unloaded	Front	Rear
Standard	35.34	38.70	15-6pr	15-6pr
Minimum for Max GVW	35.75	39.13	6.50-16-6pr	6.50-16-6pr dual

VEHICLE WEIGHTS AND LOAD DISTRIBUTION

MODEL	WITH STANDARD EQUIPMENT						WITH MINIMUM EQUIPMENT FOR MAXIMUM GVW			
	Shipping			Curb			Payload	Payload Distribution		Body Length
	Front	Rear	Total	Front	Rear	Total		Front	Rear	
3608	1920	1630	3550	1995	1735	3730	3000	0%	100%	97.56
3609	1935	1790	3725	2010	1895	3905	2850	0%	100%	91.00

10-29-54

**MODEL 3608 MEDIUM DUTY PLATFORM TRUCK  
MODEL 3609 MEDIUM DUTY STAKE TRUCK**

3/4 TON NOMINAL RATING --- 125-1/4 WHEELBASE --- 6900 lb MAXIMUM GVW

**STANDARD EQUIPMENT**

**AIR CLEANER** ----- AC make; oil-wetted type  
**AXLE, FRONT** ----- I-beam type; 2500 lb capacity  
**AXLE, REAR** ----- Full-floating type; 5000 lb capacity;  
 hypoid gears; 4.57 ratio  
**BATTERY** ----- 15 plate; 100 amp hr capacity  
**BODY** --Nominal 8-foot wood platform body with steel  
 skid strips. Entire platform is bound by a  
 steel channel-type rub rail with stake pockets  
 integrally formed. Steel cross sills and full  
 length wood side rails.  
 In addition to the above, Model 3609 has a  
 28-1/4 high stake rack.  
**BRAKES**  
**PARKING** ----- Foot-operated on rear wheels;  
 93 sq. in. area  
**SERVICE** ----- Hydraulic type; 4-wheel; 186 sq. in.  
**FRONT** ----- 12 x 2; 93 sq. in. area  
**REAR** ----- 12 x 2; 93 sq. in. area  
**BUMPER, FRONT** ----- Curved, spring type; painted  
**CAB** ----- All-steel; welded; flexibly mounted  
**CLUTCH** ---Diaphragm spring, single disc type; 10 dia.  
 100.53 sq. in. area; 238 ft lb capacity  
**COLOR, BASIC VEHICLE** ----- Juniper Green  
**COOLING SYSTEM** ----- Cellular radiator core, 4 lb  
 press. cap; 407 sq. in. frontal  
 area; 16 quart capacity  
**DISPATCH BOX** ----- 13-1/2 x 5-1/2 x 8-1/2  
**DOMELIGHT** ----- Above rear window  
**DRIVE SYSTEM** ----- Hotchkiss  
**ENGINE** ----- Thriftmaster; 235.5 cu. in. displ  
**GROSS HP** ----- 112 @ 3700 RPM  
**GROSS TORQUE** ----- 200 ft lb @ 2000 RPM

**FENDERS** ----- Front only  
**FRAME** ----- Ladder type with 5 cross members,  
 channel side rails 5-27/32 x 2-1/4 x 3/16;  
 section modulus 3.25 in.<sup>3</sup>  
**FUEL TANK** ----- Back of seat in cab; 17-1/2 gal cap.  
**GENERATOR** ----- 40 amp maximum rate  
**LIGHTS** ----- 2 Head, 2 Parking, and  
 1 Tail and Stop  
**MIRROR, REAR VIEW** ----- LH; long adjustable bracket  
**RUNNING BOARDS** ----- Short  
**SEAT** ----- Full width  
**SHOCK ABSORBERS** ---Front and rear; direct double-  
 acting 1-inch diameter piston  
**SPARE WHEEL CARRIER** ----- Underslung at rear  
**SPRINGS**  
**FRONT** ----- Semi-elliptic; 8-leaf, 38 x 1-3/4;  
 1150 lb (ea) capacity at ground  
**REAR** ----- Semi-elliptic; two-stage; 7-leaf, 46 x 2;  
 2000 lb (ea) capacity at ground  
**STEERING GEAR** ----- Recirculating-ball type; 26.24  
 ratio; 18-inch dia wheel  
**SUNSHADE** ----- Adjustable for driver  
**TIRES** ----- Front and single rear; 15-6pr;  
 1500 lb (ea) capacity  
**TOOLS** ----- 2500 lb capacity jack; jack handle;  
 tire changing iron; wheel wrench  
**TOOL BOX** ----- Under seat; 50 x 19 x 6  
**TRANSMISSION** 3-Speed, Synchro-mesh; gearshift  
 control mounted on steering column  
**VENTILATORS** ----- Top of cowl and ventipanes  
**WHEELS** ----- 5; 15 x 5.50F  
**WINDSHIELD WIPERS** ----- Dual; cowl mounted

**OPTIONAL EQUIPMENT**

For model application see Option Section

	Wt	Number
<b>AIR CLEANER: AC make, oil bath type</b>		
1 pint capacity-----*	216	
2 pint capacity-----*	216	
<b>AXLE, REAR: Single-speed; full-floating;</b>		
5.14 ratio; 5000 lb capacity-----*	208	
<b>BODY EQUIPMENT:</b>		
Platform (for 7.00-17 tires)-----	25R	230
<b>CHROME EQUIPMENT: Includes Radiator</b>		
Grille, Front Bumper & Hub Cape-----*	393	
<b>CLUTCH, HEAVY DUTY</b> -----*	227	
<b>COLORS, VEHICLE, Solid</b> -----*	234	
Two-tone-----*	438	
<b>CORNER WINDOWS, CAB</b> -----*	387	
<b>CRANKCASE VENTILATION: Vac-operated with</b>		
filtered air from oil bath air cleaners---	217	
<b>DELUXE EQUIPMENT</b> -----*	430	
<b>GENERATOR: Including voltage and</b>		
current regulator, and pulley		
for high output		
40 amp-----	13F	326
45 amp-----*	326	
50 amp-----	13F	326
55 amp-----	32F	326
55 amp, Low cut-in-----	32F	326
<b>GLASS EQUIPMENT, BODY: Tinted</b> -----*	399	
<b>GOVERNOR:</b>		
Range 2300-3200 RPM-----*	241	

	Wt	Number
<b>MIRROR, REAR VIEW:</b>		
Long, RH-----*	210	
<b>OIL FILTER: AC make</b>		
1 quart capacity-----	8F	237
2 quart capacity-----	15F	237
<b>RADIATOR, HEAVY DUTY:</b>		
17 quart capacity-----*	256	
<b>SEAT EQUIPMENT: Unison</b> -----*	264	
<b>SHOCK ABSORBER SHIELDS, REAR</b> -----*	211	
<b>SIDE DOOR KEY LOCK, LH</b> -----*	395	
<b>SPRINGS, REAR</b>		
Included in tire RPO 282;		
8-leaf; two-stage; 2500 lb (ea)		
capacity at ground		
<b>TIRES MAXIMUM</b>		
Front and dual rear; 6.50-16-6pr;		
1215 lb (ea) capacity		
(Spring weight included)-----	25F, 165R	282
<b>TRANSMISSION:</b>		
3-Speed Heavy Duty-----	13F, 4R	316
Automatic 4-Speed		
without oil cooler-----	110F, 30R	314
4-Speed, Synchro-mesh; Power take-		
off opening on left side-----	53F, 21R	318
<b>VACUUM BOOSTER AND FUEL PUMP</b> -----*	340	
<b>WINDSHIELD WIPERS:</b>		
Dual, Electric-----*	320	

\*-Weight is less than 10 pounds

10-29-54.

CHASSIS AND BODY DIMENSIONS

Model 3742 Forward Control Chassis

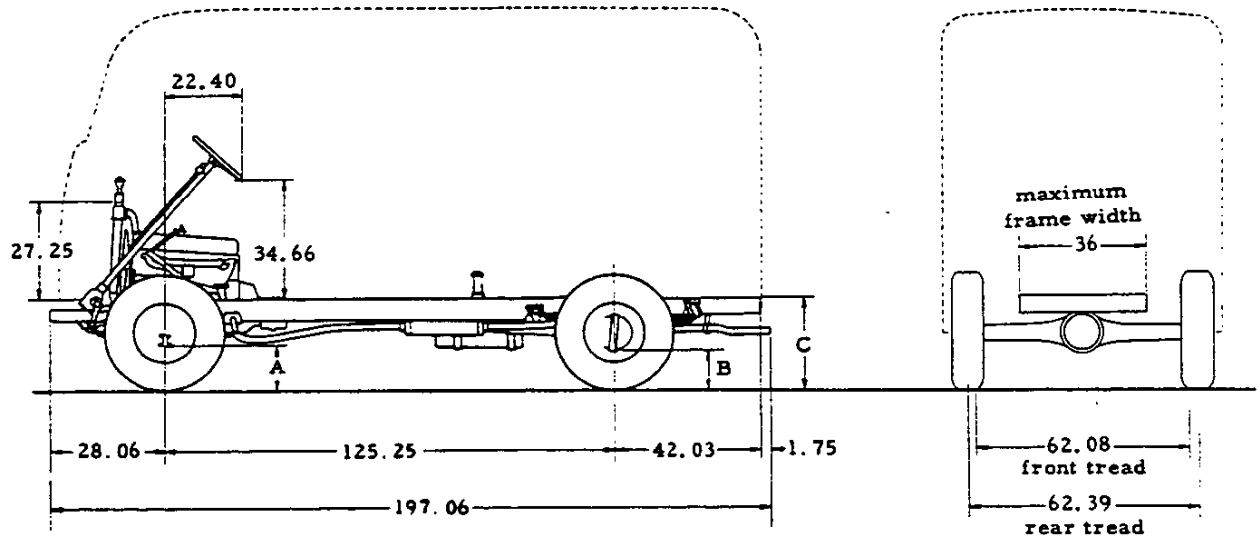

Equipment	Height Without Body and Payload		
	A	B	C
Standard	8.63	7.75	28.18
Minimum for Max GVW	10.00	9.13	29.70

To determine loaded and unloaded heights, body specifications must be known. Minimum tire equipment for Max GVW 7.00-17-6pr front and 7.00-17-8pr rear.

VEHICLE WEIGHTS AND LOAD DISTRIBUTION

MODEL	WITH STANDARD EQUIPMENT						WITH MINIMUM EQUIPMENT FOR MAXIMUM GVW			
	Shipping			Curb			Body and Payload	Payload Distribution		Body Length
	Front	Rear	Total	Front	Rear	Total		Front	Rear	
3742	1540	925	2465	1530	1145	2675	4250	Determined by style, length and weight of body.		

10-29-54

## MODEL 3742 MEDIUM DUTY FORWARD CONTROL CHASSIS

3/4 TON NOMINAL RATING --- 125-1/4 WHEELBASE --- 7000 lb MAXIMUM GVW

### STANDARD EQUIPMENT

<p>AIR CLEANER----- AC make; oil-wetted type                  AXLE, FRONT----- I-beam type; 4000 lb capacity                  AXLE, REAR --- Full-floating type; 5000 lb capacity                                      Hypoid gears; 5.14 ratio                  BATTERY ----- 15 plate; 100 amp hr capacity                  BRAKES                    PARKING ----- Foot-operated on rear wheels;                                      93 sq. in. area                    SERVICE---- Hydraulic type; 4-wheel; 186 sq. in.                      FRONT ----- 12 x 2; 93 sq. in. area                      REAR ----- 12 x 2; 93 sq. in. area                  CARBURETOR ----- Carter; up draft                  CLUTCH--Diaphragm spring; single disc type; 11 dia                                      123.7 sq. in. area; 282 ft lb capacity                  COOLING SYSTEM---- Cellular radiator core, 4 lb                                      press. cap. 407 sq.in. frontal                                      area, 16 quart capacity                  CRANKCASE VENTILATION ----- Vacuum-operated;                                      closed system                  DRIVE SYSTEM ----- Hotchkiss                  ENGINE----- Loadmaster; 235.5 cu. in. displ                  GROSS HORSEPOWER----- 110 @ 3600 RPM                  GROSS TORQUE----- 192 ft lb @ 2000 RPM                  FRAME----- Ladder type with 5 cross members                                      channel side rails 5-27/32 x 2-1/4 x 3/16;                                      section modulus 3.25 in.</p>	<p>FUEL TANK ----- Outside of frame on right side;                                      16 gallon capacity                  GENERATOR----- 40 amp maximum rate                  LIGHTS ----- 2 head, 2 parking, and                                      1 tail and stop                  RIDE STABILIZER ----- Frame to front axle                  SHOCK ABSORBERS ----- Front and rear; direct                                      double-acting;                                      1-inch dia piston                  SPRINGS                    FRONT ----- Semi-elliptic; 8-leaf, 40 x 2;                                      1740 lb (ea) capacity                    REAR ----- Semi-elliptic; 8-leaf, 46 x 2;                                      2250 lb (ea) capacity at ground                  STARTER ----- Solenoid, push-button operated                  STEERING GEAR ----- Recirculating-ball type;                                      19.8 ratio;                                      18-inch dia wheel                  TIRES ----- Front and single rear;                                      15-6pr;                                      1500 lb (ea) capacity                  TOOLS ----- 2500 lb capacity jack; jack handle;                                      tire changing iron; wheel wrench                  TRANSMISSION-- 3-Speed, Synchro-mesh; gearshift                                      control mounted on steering column                  WHEELS ----- 4; 15 x 5.50 F</p>
---	---

### OPTIONAL EQUIPMENT

For model application see Option Section

	Wt	Number		Wt	Number
AIR CLEANER: AC make; oil bath type 1 pint capacity -----	•	216	SHOCK ABSORBER SHIELDS, REAR-----	*	211
BUMPER, FRONT: Rigid channel type; painted -----	74F	367	TIRES, MAXIMUM: Front and rear; 7.50-17-8pr; 2100 lb (ea) capacity -----	45F, 47R	272
CARRIER AND SPARE WHEEL: For 15 in. tires -----	51R	384	TRANSMISSION: 3-Speed, heavy duty -----	13F, 4R	316
For 17 in. tires -----	59R	384	Automatic 4-Speed without oil cooler -----	110F, 30R	314
GENERATOR: With voltage and current regulator, and pulley for high output 40 amp -----	13F	326	4-Speed, Synchro-mesh; power take-off opening on left side ---	53F, 18R	318
45 amp -----	•	326	VACUUM BOOSTER AND FUEL PUMP ---	*	340
50 amp -----	•	326			

• - Weight is less than 10 pounds

10-29-54

CHEVROLET 1955 SPECIFICATIONS—TRUCK

MODEL 3742 DATA-79

**CHASSIS AND BODY DIMENSIONS**

Model 3802 Flat Face Cowl Chassis  
 Model 3812 Windshield Chassis

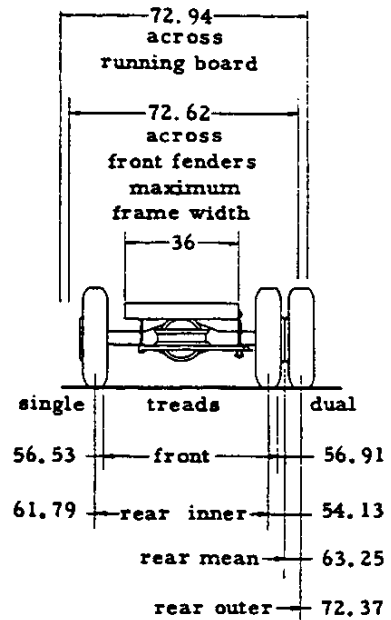
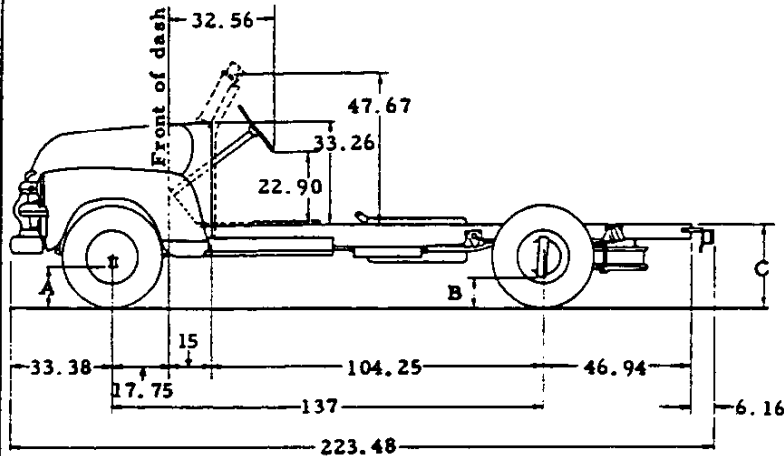

Equipment	Height Without Body and Payload		
	A	B	C
Standard	10.31	9.10	31.41
Minimum for Max GVW	10.81	9.68	31.75

To determine loaded and unloaded heights, body specifications must be known. Minimum tire equipment for max GVW is 7.00-18-8pr front and 7.00-18-8pr dual rr.

Model 3802 Junior School Bus Chassis

Equipment	Height Without Body and Payload		
	A	B	C
Model 3802, with RPO 329	10.75	9.50	30.68

To determine loaded and unloaded heights, body specifications must be known. Minimum tire equipment for max GVW is 7.50-17-8pr front and 7.50-17-10 pr rear

**VEHICLE WEIGHTS AND LOAD DISTRIBUTION**

MODEL	WITH STANDARD EQUIPMENT						WITH MINIMUM EQUIPMENT FOR MAXIMUM GVW			
	Shipping			Curb			Body and Payload	Payload Distribution		Body Length
	Front	Rear	Total	Front	Rear	Total		Front	Rear	
3802	1870	1135	3005	1925	1270	3195	5300	Determined by style, length and weight of body.		
3812 ⊕	1955	1145	3100	2010	1280	3290	5200			
3802 †	1881	1181	3062	1936	1316	3252	4300			

⊕-Estimated weight. †-Junior School Bus Chassis, Model 3802 with RPO 329.

10-29-54

**80 - MODELS 3802 AND 3812 DATA**

**CHEVROLET 1955 SPECIFICATIONS—TRUCK**

**MODEL 3802 MEDIUM DUTY FLAT FACE COWL CHASSIS  
MODEL 3812 MEDIUM DUTY WINDSHIELD COWL CHASSIS**

1 TON NOMINAL RATING --- 137 WHEELBASE --- 8800 lb MAXIMUM GVW

**STANDARD EQUIPMENT**

AIR CLEANER----- AC make, oil-wetted type	FUEL TANK-----Inside of frame on right side;
AXLE, FRONT----- I-beam type; 3500 lb capacity	18 gallon capacity
AXLE, REAR----- Full-floating type; 7200 lb capacity;	GENERATOR----- 40 amp maximum rate
hypoid gears; 5.14 ratio	LIGHTS----- 2 Head, 2 Parking, and 1 Tail and Stop
BATTERY----- 15 plate; 100 amp hr capacity	RUNNING BOARDS----- Short
BRAKES	SEAT RISER----- 3812 only
PARKING----- Foot-operated on rear wheels;	SHOCK ABSORBERS----- Front; direct double-acting;
137 sq. in. area	1-inch dia piston
SERVICE-----Hydraulic type; 4-wheel; 230 sq. in.	SPARE WHEEL CARRIER----- Underslung at rear
FRONT----- 12 x 2; 93 sq. in. area	SPRINGS
REAR----- 14 x 2-1/2; 137 sq. in. area	FRONT----- Semi-elliptic; 7-leaf, 40 x 2; 1740 lb (ea)
BUMPER, FRONT----- Curved, spring type;	capacity at ground
painted	REAR----- Semi-elliptic; two-stage; 8-leaf, 46 x 2;
CLUTCH---Diaphragm spring; single disc type; 10 dia;	2500 lb (ea) capacity at ground
100.53 sq.in. area; 238 ft lb capacity	STEERING GEAR-----Recirculating-ball type; 26.24
COLOR, BASIC VEHICLE----- Juniper Green	ratio; 18-inch dia wheel
COOLING SYSTEM----- Cellular radiator core, 4 lb	TIRES
press. cap; 407 sq.in. frontal	FRONT----- 7.00-17-6pr; 1575 lb (ea) capacity
area; 17 quart capacity	REAR----- 7.00-17-8pr; 1775 lb (ea) cap.
DISPATCH BOX -- 3802 ----- 13-7/8 x 4-3/4 x 8-1/4	TOOLS----- 3000 lb capacity jack; jack handle;
3812----- 13-1/2 x 5-1/2 x 8-1/2	tire changing iron; wheel wrench
DRIVE SYSTEM----- Hotchkiss	TOOL BOX (3812 only)-----50 x 19 x 2-3/8
ENGINE-----Thriftmaster; 235.5 cu. in. displ	TRANSMISSION- 4-Speed, Synchro-mesh; shift lever
GROSS HP----- 112 @ 3700 RPM	on transmission; provision for power
GROSS TORQUE----- 200 ft lb @ 2000 RPM	take-off on left side
FENDERS----- Front only	VENTILATOR----- Top of cowl
FRAME----- Ladder type with 5 cross members;	WHEELS----- 5; wide-base rim; 17 x 5.0
channel side rails 7 x 2-3/4 x 7/32;	WINDSHIELD WIPERS----- 3812 only;
section modulus 5.52 in. <sup>3</sup>	Dual, cowl mounted

**OPTIONAL EQUIPMENT**

For model application see Option Section

	Wt	Number		Wt	Number
AIR CLEANER: AC make; oil bath type			SCHOOL BUS EQUIPMENT		
1 pint capacity----- *	216		(3802, running boards removed)		
2 pint capacity----- *	216		7.50-17-8pr or 7.50-17-10pr		
CHROME EQUIPMENT: Includes Radiator			tires on front; 7.50-17-10pr on rear;		
Grille, Front Bumper & Hub Caps----- *	393		9-leaf springs on rear-----25F, 36R	329	
CLUTCH, HEAVY DUTY----- *	227		SHOCK ABSORBERS, REAR: Direct		
COLORS, VEHICLE, Solid----- *	234		double-acting; 1-3/8 dia piston-----18R	200	
CRANKCASE VENTILATION: Vac-operated with			SHOCK ABSORBER SHIELDS, REAR----- *	211	
filtered air from oil bath air cleaner----- *	217		SPRINGS, REAR AND AUXILIARY:		
GENERATOR: Including voltage and current			(Not used on 3802 school bus)		
regulator, and pulley for high output			Main -- 8-leaf, two-stage; auxiliary		
40 amp-----14F	326		3-leaf; capacity at ground (main and		
45 amp----- *	326		auxiliary) --- 3675 lb (ea)----- 45R	267	
50 amp----- 14F	326		STARTER, SOLENOID (3802 only)----- *	327	
55 amp----- 32F	326		TIRES, MAXIMUM: Front and dual rear,		
55 amp, Low cut-in----- 28F	326		(Not used on 3802 school bus)		
GOVERNOR: Range 2300-3200 RPM----- *	241		7.00-18-8pr; 1850 lb (ea) capacity;		
OIL FILTER: AC make			RPO 267 mandatory----- 45F, 215R	295	
1 quart capacity----- 9F	237		TRANSMISSION:		
2 quart capacity----- 15F	237		3-Speed Heavy Duty-----Minus 39F, 10R	316	
PARKING BRAKE: Prop Shaft,			Automatic 4-Speed		
Single or Dual Wheels----- *	214		with oil cooler----- 54F, 13R	314	
RADIATOR, HEAVY DUTY: 18 qt capacity----- *	256		VACUUM BOOSTER AND FUEL PUMP----- *	340	
RUNNING BOARDS (Long) & REAR FENDERS:			WINDSHIELD WIPERS		
When equip with sgle rear tires----- 78R	207		Dual, Electric (3812 only)----- *	320	

\* - Weight is less than 10 pounds.

10-29-54

**CHEVROLET 1955 SPECIFICATIONS—TRUCK**

**MODELS 3802 AND 3812 DATA-81**

**CHASSIS AND BODY DIMENSIONS**

**Model 3803 Cab Chassis**

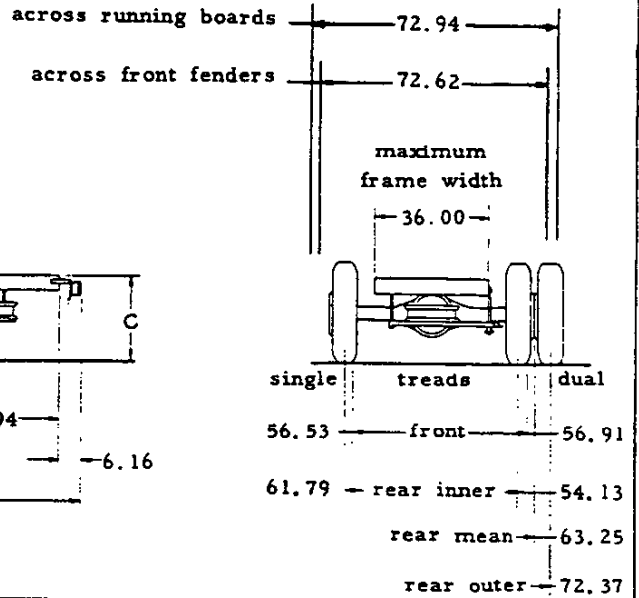
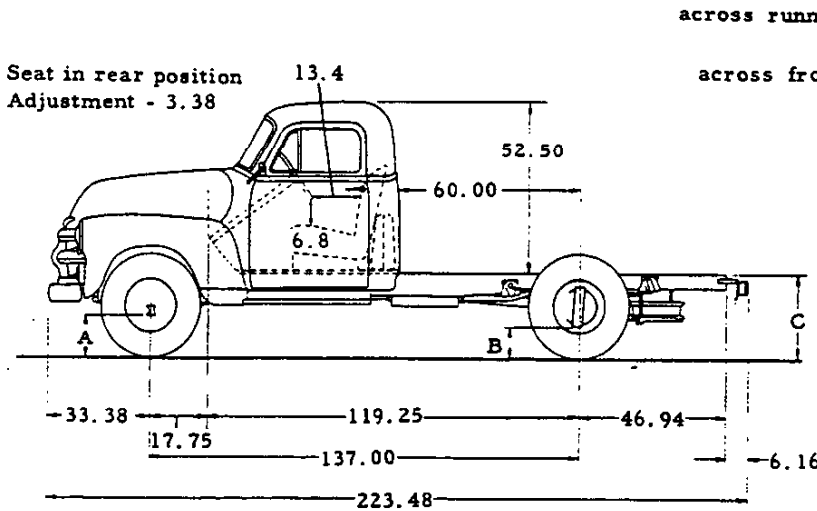

Equipment	Height Without Body and Payload		
	A	B	C
Standard	10.25	9.06	31.25
Minimum for Max GVW	10.75	9.66	31.91

To determine loaded and unloaded heights, body specifications must be known. Minimum tire equipment for Max GVW is 7.00-18-8pr front and 7.00-18-8pr dual rr.

**Model 3804 Pickup Truck**

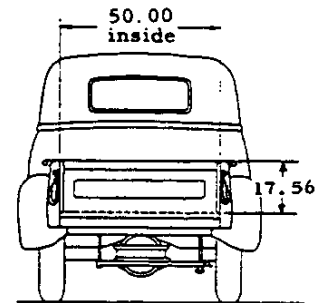
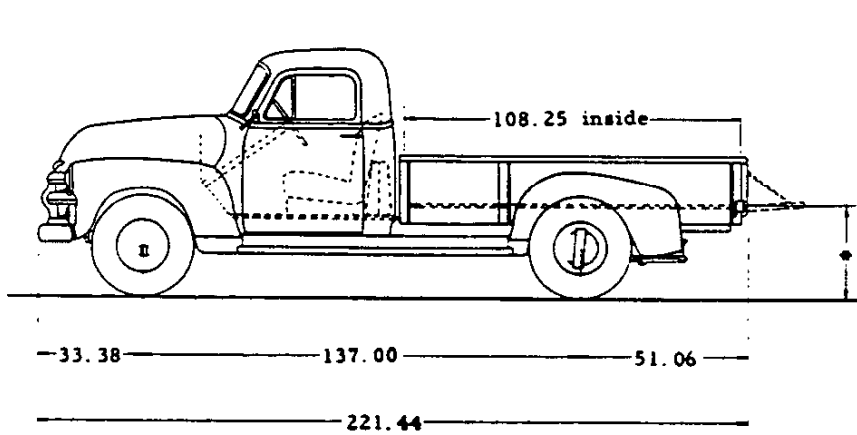

Equipment	*Platform Height		Tires	
	Loaded	Unloaded	Front	Rear
Standard	29.85	33.70	7.00-17-6pr	7.00-17-8pr
Minimum for Max GVW	29.00	33.90	7.00-17-6pr	7.50-17-8pr

**VEHICLE WEIGHTS AND LOAD DISTRIBUTION**

MODEL	WITH STANDARD EQUIPMENT						WITH MINIMUM EQUIPMENT FOR MAXIMUM GVW			
	Shipping			Curb			Body and/or Payload	Payload Distribution		Body Length
	Front	Rear	Total	Front	Rear	Total		Front	Rear	
3803	2125	1310	3435	2205	1415	3620	4900	7%	93%	96
								5%	95%	102
								1%	99%	108
3804	2160	1705	3865	2240	1810	4050	2950	4%	96%	108.25

10-29-54

**82-MODELS 3803 AND 3804 DATA**

**CHEVROLET 1955 SPECIFICATIONS—TRUCK**

**MODEL 3803 MEDIUM DUTY CAB CHASSIS  
MODEL 3804 MEDIUM DUTY PICKUP TRUCK**

1 TON NOMINAL RATING---137 WHEELBASE---8800 (3803), 7000 (3804) MAXIMUM GVW  
STANDARD EQUIPMENT

AIR CLEANER ----- AC make; oil-wetted type	FUEL TANK -- Back of seat in cab; 17-1/2 gal capacity
AXLE, FRONT ----- 1-beam type; 3500 lb capacity	GENERATOR ----- 40 amp maximum rate
AXLE, REAR ----- Full-floating type; 7200 lb capacity; Hypoid gears; 5.14 ratio	LIGHTS ----- 2 head, 2 parking, and 1 tail and stop
BATTERY ----- 15 plate; 100 amp hr capacity	MIRROR, REAR VIEW
BODY	3803 ----- LH; long adjustable bracket
3804 ----- Nominal 9-foot welded steel pickup box with wood floor and steel skid strips	3804 ----- LH; short fixed bracket
BRAKES	RUNNING BOARDS
PARKING-Foot-operated on rr wheels; 137 sq. in. area	3803 ----- Short
SERVICE ----- Hydraulic type; 4-wheel; 230 sq. in.	3804 ----- Full length
FRONT ----- 12 x 2; 93 sq. in. area	SEAT ----- Full width
REAR ----- 14 x 2-1/2; 137 sq. in. area	SHOCK ABSORBERS ----- Front only; direct double- acting; 1-inch dia piston
BUMPER, FRONT ----- Curved, spring type; painted	SPARE WHEEL CARRIER ----- Underslung at rear
CAB ----- All-steel; welded; flexibly mounted	SPRINGS ----- Semi-elliptic
CLUTCH ---Diaphragm spring; single disc type; 10 dia; 100.53 sq. in. area; 238 ft lb capacity	FRONT-7-leaf, 40 x 2; 1740 lb (ea) capacity of ground
COLOR, BASIC VEHICLE ----- Juniper Green	REAR ----- Two-stage; 8-leaf; 46 x 2; 2500 lb (ea) capacity at ground
COOLING SYSTEM ----- Cellular radiator core; 407 sq. in. frontal area; 4 lb pressure cap; 17 qt capacity	STEERING GEAR ----- Recirculating-ball type; 26.24 ratio; 18-inch dia wheel
DISPATCH BOX ----- 13-1/2 x 5-1/2 x 8-1/2	SUNSHADE ----- Adjustable; for driver
DOME LIGHT ----- Above rear window	TIRES
DRIVE SYSTEM ----- Hotchkiss	FRONT ----- 7.00-17-6 pr; 1575 lb (ea) capacity
ENGINE ----- Thriftmaster; 235.5 cu. in. displ	SINGLE REAR ----- 7.00-17-8 pr; 1775 lb (ea) cap.
GROSS HP ----- 112 @ 3700 RPM	TOOLS ----- 3000 lb capacity jack; jack handle; tire changing iron; wheel wrench
GROSS TORQUE ----- 200 ft lb @ 2000 RPM	TOOL BOX ----- Under seat, 50 x 19 x 6
FENDERS ----- 3804 Front and rear; 3803 Front only	TRANSMISSION --- 4-speed, synchro-mesh; shift lever on transmission; provision for power take-off on left side
FRAME ----- Ladder type with 5 cross members, channel side rails 7 x 2-3/4 x 7/32; section modulus 5.52 in <sup>3</sup>	VENTILATORS ----- Top of cowl, and ventipanes
	WHEELS ----- 5; wide-base rim: 17 x 5.0
	WINDSHIELD WIPERS ----- Dual; cowl mounted

**OPTIONAL EQUIPMENT**

For model application see Option Section

	Wt	Number		Wt	Number
AIR CLEANER: AC make, oil bath type			RADIATOR, HEAVY DUTY: 18 qt cap. ----*		256
1 pint capacity ----- *	216		RUNNING BOARDS (long) AND REAR		
2 pint capacity ----- *	216		FENDERS (3803 only)----When		
BUMPER, REAR: (3804 only) ----- 32R	218		equipped with single rear tires-----	78R	207
CHROME EQUIPMENT: Includes Radiator			SEAT EQUIPMENT: Unison ----- *		264
Grille, Front Bumper, & Hub Caps ---- *	393		SIDE DOOR, LH, and WHEEL		
CLUTCH, HEAVY DUTY ----- *	227		CARRIER LOCK EQUIPMENT ----- *		395
COLORS, VEHICLE, Solid ----- *	234		SHOCK ABSORBERS, REAR:		
Two-tone ----- *	438		Direct double-acting; 1-3/8 dia piston-18R	200	
CORNER WINDOWS, CAB: Clear or Tinted *	387		SHOCK ABSORBERS SHIELDS, REAR-----*	211	
CRANKCASE VENTILATION: Vac-operated with filtered air from oil bath air cleaner----*	217		SPRINGS, REAR AND AUXILIARY:		
DELUXE EQUIPMENT ----- *	431		Main -- 8-leaf, two-stage;		
GENERATOR: Including voltage and current regulator, and pulley for high output			Auxiliary -- 3-leaf, cap. at ground		
40 amp ----- 14F	326		(main and auxiliary) -- 3675 lb (ea)-- 45R	267	
45 amp ----- *	326		TIRES, MAXIMUM:		
50 amp ----- 14F	326		3803 -- Front and Dual rear, 7.00-18-8pr;		
55 amp ----- 32F	326		1850 lb (ea) capacity ----- 42F, 215R	295	
55 amp, low cut-in ----- 28F	326		3804 -- Front and Single rear, 7.50-17-8pr; 2100 lb (ea) cap. --18R, 11R	272	
GLASS EQUIPMENT: Tinted ----- *	399		TRANSMISSION:		
GOVERNOR: Range 2300-3200 RPM ---- *	241		3-Speed, Heavy Duty ----- Minus 39F, 10R	316	
MIRROR, REAR VIEW:			Automatic 4-Speed		
3803-Long, RH; short, RH or LH ----- *	210		with oil cooler ----- 54F, 13R	314	
3804-Long, RH or LH; Short, RH ----- *	210		VACUUM BOOSTER AND FUEL PUMP --- *	340	
OIL FILTER: AC make			WHEEL CARRIER EQUIPMENT:		
1 quart capacity ----- 8F	237		(Side Mounted) 3804 only ----- *	342	
2 quart capacity ----- 15F	237		WINDSHIELD WIPERS:		
			Dual, Electric ----- *	320	

\* - Weight is less than 10 pounds



CHASSIS AND BODY DIMENSIONS

Model 3805 Panel Truck

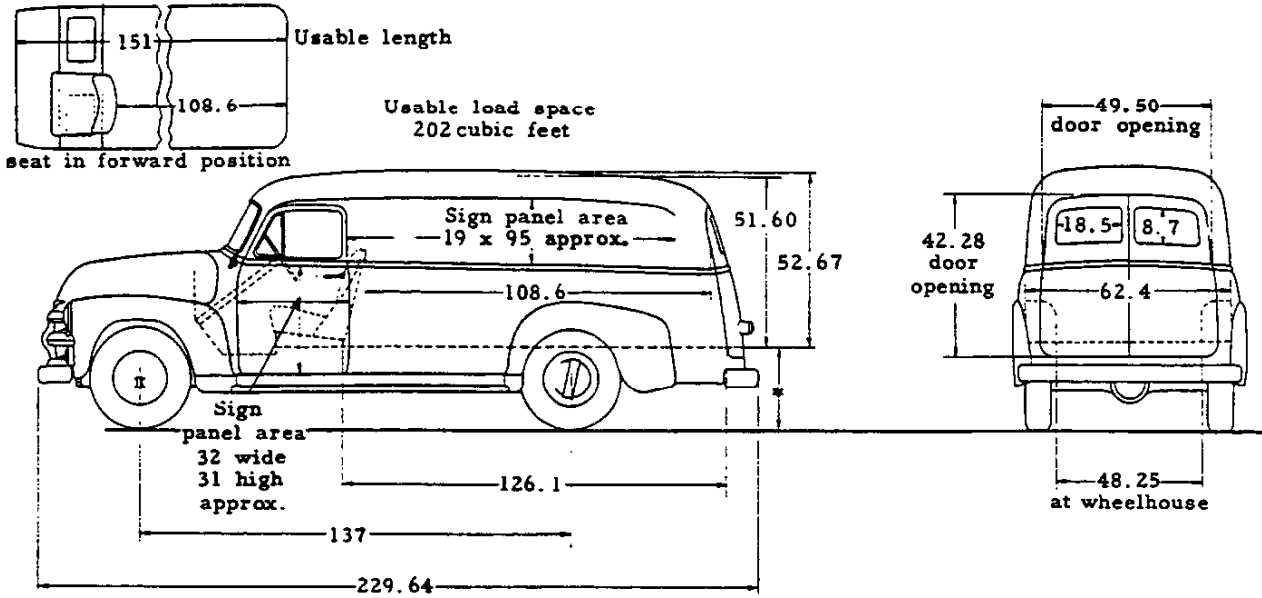

Equipment	*Platform Height		Tires	
	Loaded	Unloaded	Front	Rear
Standard	30.25	33.75	7.00-17-6pr	7.00-17-8pr
Minimum for Max GVW	29.00	33.75	7.00-17-6pr	7.50-17-8pr

Model 3807 Canopy Express Truck

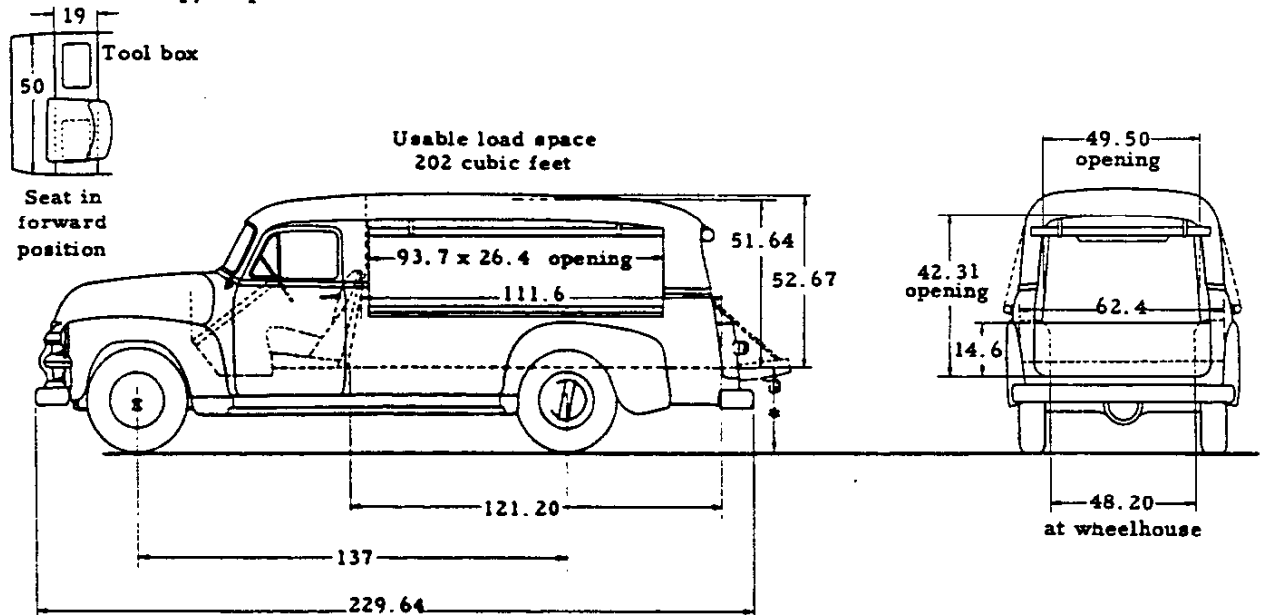

Equipment	*Platform Height		Tires	
	Loaded	Unloaded	Front	Rear
Standard	30.25	34.00	7.00-17-6pr	7.00-17-8pr
Minimum for Max GVW	29.50	34.25	7.00-17-6pr	7.50-17-8pr

VEHICLE WEIGHTS AND LOAD DISTRIBUTION

MODEL	WITH STANDARD EQUIPMENT						WITH MAXIMUM EQUIPMENT FOR MAXIMUM GVW			
	Shipping			Curb			Payload	Payload Distribution		
	Front	Rear	Total	Front	Rear	Total		Front	Rear	
3805	2080	2090	4170	2135	2225	4360	2650	9%	91%	
3807 ⊕	2100	2005	4105	2155	2140	4295	2700	7%	93%	

⊕-Estimated Weight

10-29-54

**MODEL 3805 MEDIUM DUTY PANEL TRUCK  
MODEL 3807 MEDIUM DUTY CANOPY EXPRESS TRUCK**

1 TON NOMINAL RATING --- 137 WHEELBASE --- 7000 lb MAXIMUM GVW

**STANDARD EQUIPMENT**

AIR CLEANER----- AC make, oil-wetted type	FENDERS-----Front and Rear
AXLE, FRONT----- 1-beam type, 3500 lb capacity	FRAME-----Ladder type with 5 cross members, channel side rails 7 x 2-3/4 x 7/32; section modulus 5.52 in. <sup>3</sup>
AXLE, REAR----- Full-floating type; 7200 lb capacity; hypoid gears; 5.14 ratio	FUEL TANK-----Inside of frame on right; 18 gal cap.
BATTERY----- 15 plate; 100 amp hr capacity	GENERATOR----- 40 amp maximum rate
BODY	LIGHTS----- 2 Head, 2 Parking, and 1 Tail and Stop
PANEL----- All steel panel with plywood floor and steel skid strips. Two rear doors for full width opening at rear.	MIRROR, REAR VIEW----- LH; short fixed bracket
CANOPY--- All-steel with plywood floor and steel skid strips. Tail gate in rear. Weather- proof curtains for load compartment, side and rear openings. Sheet metal partition with window between driver compartment and load space.	RUNNING BOARDS----- Full length
EXPRESS	SEAT----- Bucket type; driver only
BRAKES	SHOCK ABSORBERS-----Front only; direct double- acting, 1-inch dia piston
PARKING----- Foot-operated on rear wheels; 137 sq. in. area	SPARE WHEEL CARRIER-----Underslung at rear
SERVICE----- Hydraulic type; 4-wheel; 230 sq. in.	SPRINGS
FRONT----- 12 x 2; 93 sq. in. area	FRONT----- Semi-elliptic; 7-leaf, 40 x 2 1740 lb (ea) capacity at ground
REAR----- 14 x 2-1/2; 137 sq. in. area	REAR----- Semi-elliptic; two-stage, 8-leaf, 46 x 2; 2500 lb (ea) capacity at ground
BUMPERS----- Curved, spring type; painted	STEERING GEAR-----Recirculating-ball type; 26.24 ratio; 18-inch dia wheel
CLUTCH--- Diaphragm spring; single disc type; 10 dia; 100.53 sq. in. area; 238 ft lb capacity	SUNSHADE----- Adjustable; for driver
COLOR, BASIC VEHICLE----- Juniper Green	TIRES
COOLING SYSTEM-----Cellular radiator core, 4 lb press. cap; 407 sq. in. frontal area; 17 quart capacity	FRONT----- 7.00-17-6pr; 1575 lb (ea) cap.
DISPATCH BOX----- 13-1/2 x 5-1/2 x 8-1/2	REAR, SINGLE----- 7.00-17-8pr; 1775 lb (ea) cap.
DOME LIGHT----- Above driver on centerline of car	TOOLS-----3000 lb capacity jack; jack handle; tire changing iron; wheel wrench
DRIVE SYSTEM----- Hotchkiss	TOOL BOX----- Under seat; 50 x 19 x 2-3/8
ENGINE----- Thriftmaster; 235.5 cu. in. displ	TRANSMISSION--- 4-Speed, Synchro-mesh; shift lever on transmission; provision for power take-off on left side
GROSS HP----- 112 @ 3700 RPM	VENTILATORS----- Top of cowl and ventpanes
GROSS TORQUE----- 200 ft lb @ 2000 RPM	WHEELS----- 5; wide-base rim; 17 x 5.0
	WINDSHIELD WIPERS----- Dual; cowl mounted

**OPTIONAL EQUIPMENT**

For model application see Option Section

	Wt	Number		Wt	Number
AIR CLEANER: AC make, oil bath type			RADIATOR, HEAVY DUTY:		
1 pint capacity----- *	216		18 quart capacity----- *	256	
2 pint capacity----- *	216		SEAT, AUXILIARY:		
CHROME EQUIPMENT: Includes Radiator			Imitation leather----- 24F, 19R	263	
Grille, Fr & Rr Bumpers & Hub Caps -- *	393		SHOCK ABSORBERS, REAR: Direct		
CLUTCH, HEAVY DUTY----- *	227		double acting; 1-3/8 diameter piston---- 18R	200	
COLORS, VEHICLE, Solid----- *	234		SHOCK ABSORBER SHIELDS, REAR----- *	211	
Two-tone----- *	439		SIDE DOOR KEY LOCK, LH----- *	395	
CRANKCASE VENTILATION: Vac-operated with filtered air from oil bath air cleaner--- *	217		SPRINGS, REAR AND AUXILIARY:		
DELUXE EQUIPMENT----- *	430		Main -- 8-leaf, two-stage		
GENERATOR: Including voltage current regulator, and pulley for high output			Auxiliary -- 3-leaf		
40 amp----- 14F	326		Capacity at ground (Main and Auxiliary) -- 3675 lb (ea)----- 45R	267	
45 amp----- *	326		TIRES, MAXIMUM:		
50 amp----- 14F	326		Front and Single Rear,		
55 amp----- 32F	326		7.50-17-8pr;		
55 amp, Low cut-in----- 28F	326		2100 lb (ea) capacity----- 18F, 11R	272	
GLASS EQUIPMENT: (Tinted)----- *	399		TRANSMISSION:		
GOVERNOR: Range 2300-3200 RPM----- *	241		3-Speed, Heavy Duty----- Minus 39F, 10R	316	
LAMPS, DUAL TAIL AND STOP----- *	249		Automatic 4-Speed		
MIRROR, REAR VIEW: Short, RH----- *	210		with oil cooler----- 54F, 13R	314	
OIL FILTER: AC make			VACUUM BOOSTER		
1 quart capacity----- 8F	237		AND FUEL PUMP----- *	340	
2 quart capacity----- 15F	237		WINDSHIELD WIPERS		
			Dual, Electric----- *	320	

\*--Weight is less than 10 pounds

CHASSIS AND BODY DIMENSIONS

Model 3808 Platform Truck

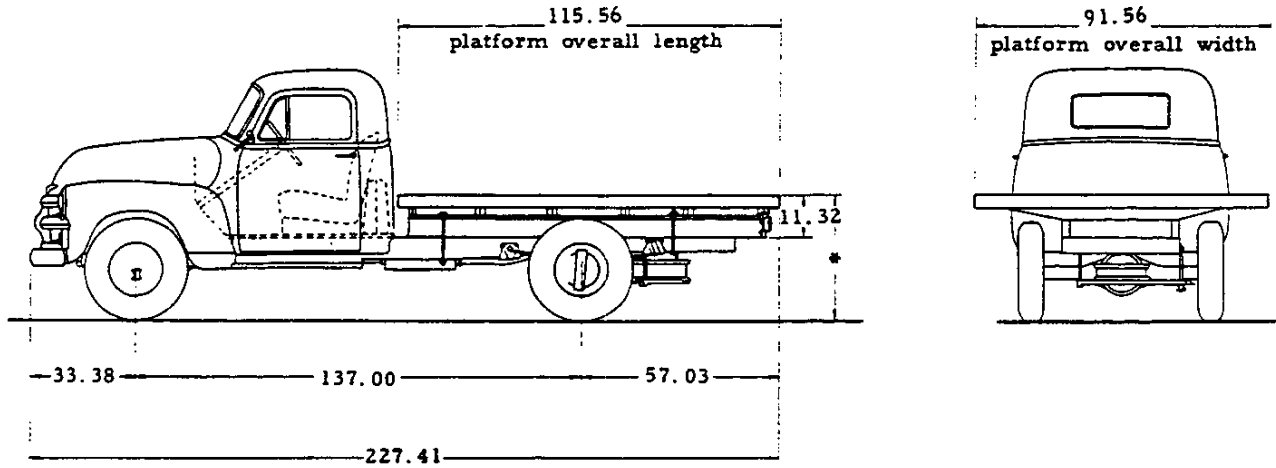

Equipment	*Platform Height		Tires	
	Loaded	Unloaded	Front	Rear
Standard	37.92	41.85	7.00-17-6pr	7.00-17-8pr
Minimum for Max GVW	37.53	42.50	7.00-18-8pr	7.00-18-8pr

Model 3809 Stake Truck

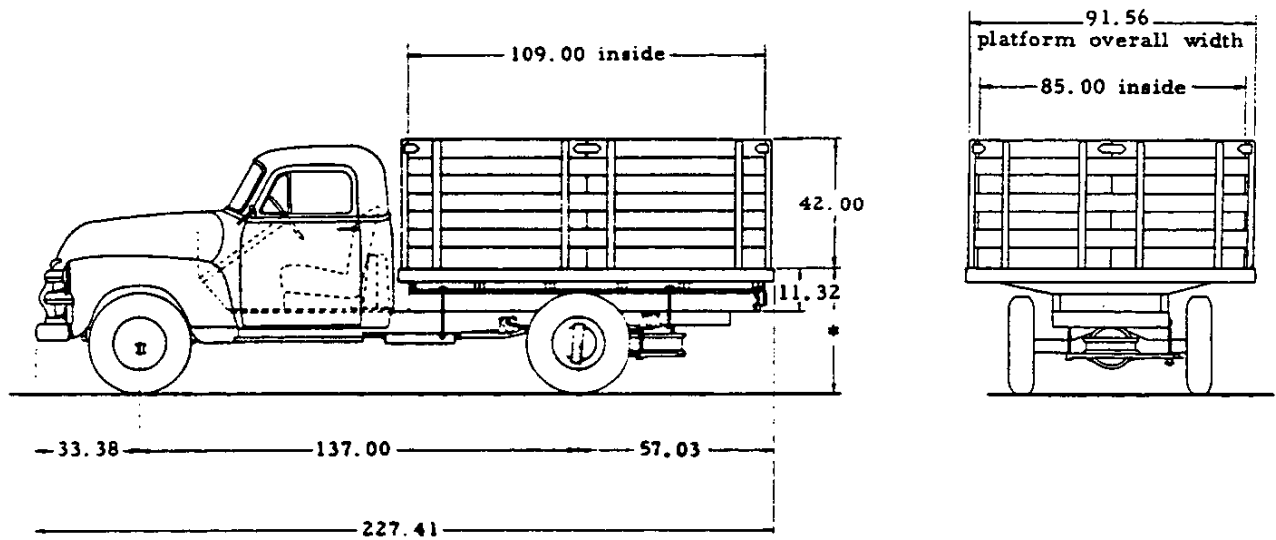

Equipment	*Platform Height		Tires	
	Loaded	Unloaded	Front	Rear
Standard	37.92	41.52	7.00-17-6pr	7.00-17-8pr
Minimum for Max GVW	37.53	41.90	7.00-18-8pr	7.00-18-8pr

VEHICLE WEIGHTS AND LOAD DISTRIBUTION

MODEL	WITH STANDARD EQUIPMENT						WITH MINIMUM EQUIPMENT FOR MAXIMUM GVW			
	Shipping			Curb			Payload	Payload Distribution		Body Length
	Front	Rear	Total	Front	Rear	Total		Front	Rear	
3808	2130	1860	3990	2210	1965	4175	4350	0%	100%	115.56
3809	2150	2105	4255	2230	2210	4440	4100	1%	99%	109.00

10-29-54

86 - MODELS 3808 AND 3809 DATA

CHEVROLET 1955 SPECIFICATIONS—TRUCK

**MODEL 3808 MEDIUM DUTY PLATFORM TRUCK  
MODEL 3809 MEDIUM DUTY STAKE TRUCK**

1 TON NOMINAL RATING --- 137 WHEELBASE --- 8800 lb MAXIMUM GVW

**STANDARD EQUIPMENT**

<p>AIR CLEANER ----- AC make; oil-wetted type          AXLE, FRONT ----- I-beam type; 3500 lb capacity          AXLE, REAR ----- Full-floating; 7200 lb capacity;                                          Hypoid gears; 5.14 ratio          BATTERY ----- 15 plate; 100 amp hr capacity          BODY--Nominal 9-foot wood platform body with steel                skid strips. Entire platform is bound by a                steel channel-type rub rail with stake pockets                integrally formed. Steel cross sills and full                length wood side sills. 3809 is equipped with                42 high stake rack.          BRAKES            PARKING ----- Foot-operated on rear wheels;                                          137 sq. in. area            SERVICE ----- Hydraulic type; 4-wheel; 230 sq. in.              FRONT ----- 12 x 2; 93 sq. in. area              REAR ----- 14 x 2-1/2; 137 sq. in. area          BUMPER, FRONT ----- Curved, spring type; painted          CAB-----All-steel; welded; flexibly mounted          CLUTCH--Diaphragm spring; single disc type; 10 dia;                100.53 sq. in. area; 238 ft lb capacity          COLOR, BASIC VEHICLE ----- Juniper Green          COOLING SYSTEM --- Cellular radiator core, 4 lb                                          press. cap; 407 sq. in. frontal                                          area; 17 quart capacity          DISPATCH BOX ----- 13-1/2 x 5-1/2 x 8-1/2          DOME LIGHT ----- Above rear windows          DRIVE SYSTEM ----- Hotchkiss          ENGINE ----- Thriftmaster; 235.5 cu. in. displ            GROSS HP ----- 112 @ 3700 RPM            GROSS TORQUE ----- 200 ft lb @ 2000 RPM          FENDERS ----- Front only</p>	<p>FRAME -----Ladder type with 5 cross members,                                          channel side rails 7 x 2-3/4 x 7/32;                                          section modulus 5.52 in<sup>3</sup>          FUEL TANK--- Back of seat in cab: 17-1/2 gal cap.          GENERATOR ----- 40 amp maximum rate          LIGHTS ----- 2 head, 2 parking, and 1 tail and stop          MIRROR, REAR VIEW -- LH; long adjustable bracket          RUNNING BOARDS ----- Short          SEAT ----- Full width          SHOCK ABSORBERS ----- Front; direct double-acting;                                          1-inch diameter piston          SPARE WHEEL CARRIER ----- Underslung at rear          SPRINGS            FRONT ----- Semi-elliptic; 7-leaf, 40 x 2;                                          1740 lb (ea) capacity at ground            REAR ----- Semi-elliptic; two-stage; 8-leaf, 46 x 2;                                          2500 lb (ea) capacity at ground          STEERING GEAR ----- Recirculating-ball type; 26.24                                          ratio; 18-inch dia wheel          SUNSHADE ----- Adjustable; for driver          TIRES            FRONT ----- 7.00-17-6pr; 1575 lb (ea) capacity            SINGLE REAR ----- 7.00-17-8pr; 1775 lb (ea) cap.          TOOLS ----- 3000 lb capacity jack; jack handle;                                          tire changing iron; wheel wrench          TOOL BOX ----- Under seat; 50 x 19 x 6          TRANSMISSION -- 4-speed, synchro-mesh; shift lever                                          on transmission; provision for                                          power take-off on left side          VENTILATORS ----- Top of cowl and ventipanes          WHEELS ----- 5; wide-base rim; 17 x 5.0          WINDSHIELD WIPERS ----- Dual; cowl mounted</p>
--	--

**OPTIONAL EQUIPMENT**

For model application see Option Section

	Wt	Number		Wt	Number
AIR CLEANER: AC make, oil bath type			OIL FILTER: AC make		
1 pint capacity ----- *	216		1 quart capacity ----- 8F	237	
2 pint capacity ----- *	216		2 quart capacity ----- 15F	237	
CHROME EQUIPMENT: Includes Radiator			RADIATOR, HEAVY DUTY:		
Grille, Front Bumper & Hub Caps ----- *	393		18 quart capacity ----- *	256	
CLUTCH, HEAVY DUTY ----- *	227		SEAT EQUIPMENT: Unison ----- *	264	
COLORS, VEHICLE, Solid ----- *	234		SHOCK ABSORBERS, REAR:		
Two-tone ----- *	438		Direct double-acting; 1-3/8 dia piston-- 18R	200	
CORNER WINDOWS, CAB: Clear or tinted --*	387		SHOCK ABSORBER SHIELDS, REAR ----- *	211	
CRANKCASE VENTILATION: Vac-operated with filtered air from oil bath air cleaner --- *	217		SIDE DOOR KEY LOCK, LH ----- *	395	
DELUXE EQUIPMENT ----- *	431		SPRINGS, REAR AND AUXILIARY:		
GENERATOR: Including voltage and current regulator, and pulley for high output			Main--8-leaf; two-stage		
40 amp ----- 14F	326		Auxiliary--3-leaf; Capacity at Ground		
45 amp ----- *	326		(Main and Auxiliary)--3675 lb (ea) -- 45R	267	
50 amp ----- 14F	326		TIRES, MAXIMUM: Front and Dual Rear,		
55 amp ----- 32F	326		7.00-18-8pr; 1850 lb (ea) capacity;		
55 amp, low cut-in ----- 28F	326		RPO 267 mandatory ----- 42F, 215R	295	
GLASS EQUIPMENT			TRANSMISSION:		
Tinted ----- *	399		3-Speed Heavy Duty ----- Minus 39F, 10R	316	
GOVERNOR: Range 2300-3200 RPM ----- *	241		Automatic 4-Speed		
MIRROR, REAR VIEW:			with oil cooler ----- 54F, 13R	314	
Long, RH ----- *	210		VACUUM BOOSTER AND FUEL PUMP --- *	340	
			WINDSHIELD WIPERS:		
			Dual, Electric ----- *	320	

\*-Weight is less than 10 pounds

CHASSIS AND BODY DIMENSIONS

Model 3942 Forward Control Chassis

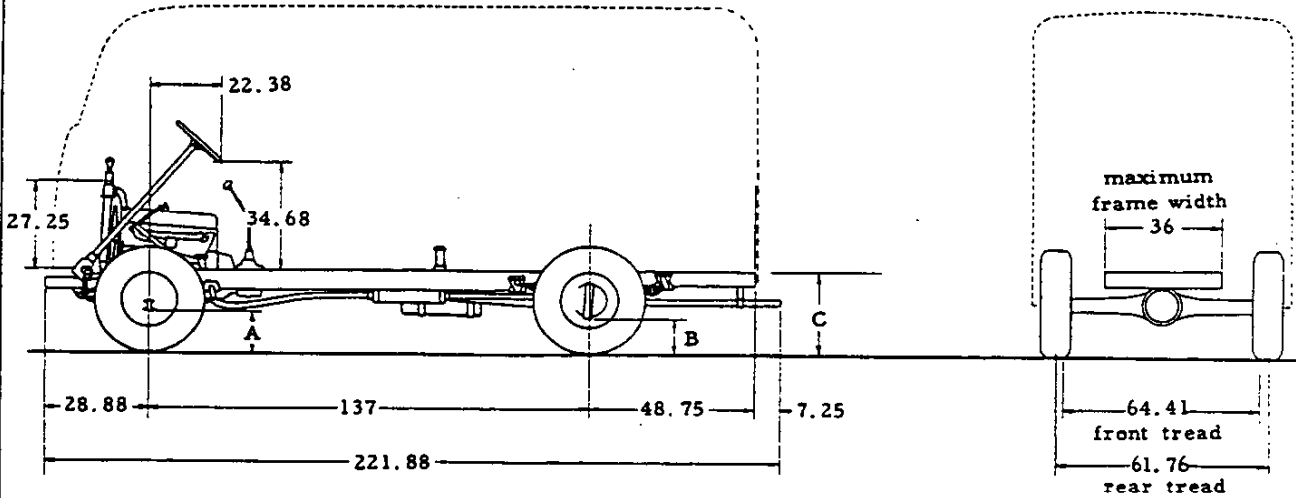

Equipment	Height Without Body and Payload		
	A	B	C
Standard	9.94	9.12	29.75
Minimum for Max GVW	10.44	9.68	30.00

To determine loaded and unloaded heights, body specifications must be known. Minimum tire equipment for Max GVW is 7.00-18-8pr front and 7.00-18-8pr dual rr.

VEHICLE WEIGHTS AND LOAD DISTRIBUTION

MODEL	WITH STANDARD EQUIPMENT						WITH MINIMUM EQUIPMENT FOR MAXIMUM GVW			
	Shipping			Curb			Body and Payload	Payload Distribution		Body Length
	Front	Rear	Total	Front	Rear	Total		Front	Rear	
3942	1685	1040	2725	1695	1255	2950	6750	Determined by style, length and weight of body		

10-29-54

88 - MODEL 3942 DATA

CHEVROLET 1955 SPECIFICATIONS—TRUCK

## MODEL 3942 MEDIUM DUTY FORWARD CONTROL CHASSIS

1-TON NOMINAL RATING --- 137 WHEELBASE --- 10000 lb MAXIMUM GVW

### STANDARD EQUIPMENT

AIR CLEANER ----- AC make; oil-wetted type  
 AXLE, FRONT ----- I-beam type;  
 4000 lb cap.  
 AXLE, REAR -- Full-floating type; 7200 lb capacity;  
 Hypoid gears; 5.14 ratio  
 BATTERY ----- 100 amp hr capacity;  
 15 plate  
 BRAKES  
 PARKING ----- Foot-operated on rear wheels;  
 137 sq. in. area  
 SERVICE ---- Hydraulic type; 4-wheel; 230 sq. in.  
 FRONT ----- 12 x 2; 93 sq. in. area  
 REAR ----- 14 x 2-1/2; 137 sq. in. area  
 CARBURETOR ----- Carter; up draft  
 CLUTCH ----- Diaphragm spring; single disc type;  
 11 dia; 123.7 sq. in. area;  
 282 ft lb capacity  
 COOLING SYSTEM ----- Cellular radiator core, 4 lb  
 press. cap 407 sq. in. frontal  
 area; 16 quart capacity  
 CRANKCASE VENTILATION ----- Vacuum-operated;  
 closed system  
 DRIVE SYSTEM ----- Hotchkiss  
 ENGINE ----- Loadmaster; 235.5 cu. in. displ  
 GROSS HP ----- 110 @ 3600 RPM  
 GROSS TORQUE ----- 192 ft lb @ 2000 RPM

FRAME ----- Ladder type with 5 cross members  
 channel side rails 7 x 2-3/4 x 7/32;  
 section modulus 5.52 in<sup>3</sup>  
 FUEL TANK -Outside of frame on right side; 16 gal cap.  
 GENERATOR ----- 40 amp maximum rate  
 LIGHTS ----- 2 head, 2 parking, and  
 1 tail and stop  
 RIDE STABILIZER ----- Frame to front axle  
 SHOCK ABSORBERS ---- Front only; direct, double-  
 acting; 1-inch dia piston  
 SPRINGS  
 FRONT ----- Semi-elliptic; 8-leaf, 40 x 2;  
 1740 lb (ea) capacity at ground  
 REAR ----- Semi-elliptic; 8-leaf, 46 x 2;  
 2250 lb (ea) capacity at ground  
 STARTER ----- Solenoid, push button operated  
 STEERING GEAR ----- Recirculating-ball type; 19.8  
 ratio; 18-inch dia wheel  
 TIRES ----- Front and single rear; 7.00-17-6pr;  
 1575 lb (ea) capacity  
 TOOLS ----- 3000 lb capacity jack; jack handle;  
 tire changing iron; wheel wrench  
 TRANSMISSION-- 4-speed, synchro-mesh; shift lever  
 on transmission; provision for  
 power take-off on left side  
 WHEELS ----- 4; wide-base rim; 17 x 5.0

### OPTIONAL EQUIPMENT

For model application see Option Section

	Wt	Number		Wt	Number
AIR CLEANER:					
AC make; oil bath type					
1 pint capacity ----- *	216				
BUMPER, FRONT					
Rigid, channel-type; painted -----	74F	367			
CARRIER AND SPARE WHEEL:					
For 17 diameter tires -----	55R	384			
For 18 diameter tires -----	60R	384			
GENERATOR:					
Including voltage and current					
regulator, and pulley for high					
output					
40 amp -----	13F	326			
45 amp ----- *	326				
50 amp ----- *	326				
PROPELLER SHAFT BRAKE:					
10 dia x 2-1/2 wide;					
35 sq. in. area ----- *	214				
	*				
	. Weight is less than 10 pounds				
SHOCK ABSORBERS, REAR:					
Double-acting; lever type					
1-1/2 diameter piston -----	23R	200			
Same as above plus rear stabilizer ---	28R	200			
SPRINGS, REAR AND AUXILIARY:					
Main -- 8-leaf; two-stage					
Auxiliary -- 3-leaf;					
Capacity at ground (main and					
auxiliary) -- 3675 (ea) -----	53R	267			
TIRES, MAXIMUM:					
Front and dual rear; 7.00-18-8pr;					
1850 lb (ea) cap. RPOs 200 and 267 are					
mandatory with this option ----	35F, 215R	295			
TRANSMISSION:					
3-Speed, heavy duty -----	Minus 43F, 10R	316			
Automatic 4-Speed					
with oil cooler -----	57F, 13R	314			
VACUUM BOOSTER AND FUEL PUMP ----- *	340				

10-29-54

CHEVROLET 1955 SPECIFICATIONS—TRUCK

MODEL 3942 DATA - 89

CHASSIS AND BODY DIMENSIONS

Model 4102 Flat Face Cowl Chassis  
 Model 4112 Windshield Cowl Chassis

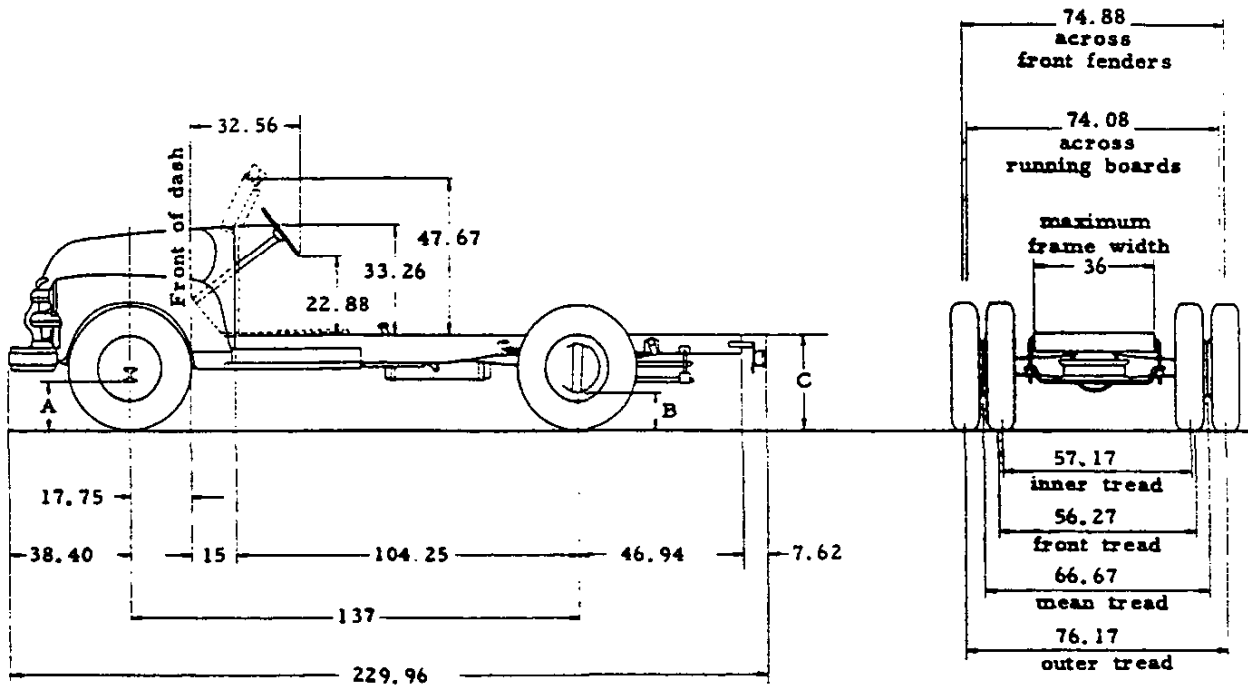

Equipment	Height Without Body and Payload		
	A	B	C
Standard	11.19	8.91	32.81
Minimum for Max GVW	11.69	10.25	34.70

To determine loaded and unloaded heights, body specifications must be known. Minimum tire equipment for Max GVW is 7.00-20-8pr front and 7.50-20-8pr dual rr.

VEHICLE WEIGHTS AND LOAD DISTRIBUTION

MODEL	WITH STANDARD EQUIPMENT						WITH MINIMUM EQUIPMENT FOR MAXIMUM GVW			
	Shipping			Curb			Body and Payload	Payload Distribution		Body Length
	Front	Rear	Total	Front	Rear	Total		Front	Rear	
4102	2010	1620	3630	2050	1770	3820	9850	Determined by style, length and weight of body.		
4112 Ⓞ	2150	1585	3735	2190	1735	3925				

Ⓞ-Estimated weight

10-29-54

90 -MODELS 4102 AND 4112 DATA

CHEVROLET 1955 SPECIFICATIONS—TRUCK

**MODEL 4102 HEAVY DUTY FLAT FACE COWL CHASSIS  
MODEL 4112 HEAVY DUTY WINDSHIELD COWL CHASSIS**

1-1/2 TON NOMINAL RATING --- 137 WHEELBASE ---14000 lb MAXIMUM GVW

STANDARD EQUIPMENT	
AIR CLEANER -----	AC make; oil-wetted type
AXLE, FRONT -----	1-beam type; 4000 lb capacity
AXLE, REAR -----	Full-floating; 11000 lb capacity; Hypoid gears; 6.17 ratio
BATTERY -----	15 plate; 100 amp hr capacity
BRAKES	
PARKING -----	Hand-operated on propeller shaft; 35 sq. in. area
SERVICE ----	Hydraulic type; 4-wheel; 375 sq. in.
FRONT -----	14 x 2-1/2; 134 sq. in. area
REAR -----	15 x 4; 241 sq. in. area
BUMPER, FRONT ----	Rigid, channel-type; painted
CLUTCH--	Diaphragm spring; single disc type; 11 dia; 123.7 sq. in. area; 282 ft lb capacity
COLOR, BASIC VEHICLE -----	Juniper Green
COOLING SYSTEM ----	Cellular radiator core, 4 lb press. cap; 407 sq. in. frontal area; 17 quart capacity
DISPATCH BOX ----	4102 -- 13-7/8 x 4-3/4 x 8-1/4; 4112 -- 13-1/2 x 5-1/2 x 8-1/2
DRIVE SYSTEM -----	Hotchkiss
ENGINE -----	Thriftmaster; 235.5 cu. in. displ
GROSS HP -----	112 @ 3700 RPM
GROSS TORQUE -----	200 ft lb @ 2000 RPM
FENDERS -----	Front only
FRAME -----	Ladder type with 5 cross members channel side rails 7 x 2-3/4 x 7/32; section modulus 5.52 in <sup>3</sup>
FUEL TANK -----	Outside of frame on right side; 18 gallon capacity
GENERATOR -----	45 amp maximum rate
LIGHTS -----	2 head, 2 parking, and 1 tail and stop
RUNNING BOARDS -----	Short
SEAT RISER -----	4112 only
SPARE WHEEL CARRIER -----	Underslung at rear
SPRINGS	
FRONT -----	Semi-elliptic; 7-leaf; 40 x 2; 1740 lb (ea) capacity at ground
REAR -----	Semi-elliptic; 11-leaf, 46 x 2-1/2; 4465 lb (ea) capacity at ground
STEERING GEAR ----	Recirculating-ball type; 26.24 ratio; 18-inch dia wheel
TIRES -----	Front and dual rear; 6.50-20-6 pr; 1700 lb (ea) capacity
TOOLS -----	8250 lb capacity jack; tire changing iron; wheel wrench
TOOL BOX (4112 only) -----	50 x 19 x 2-3/8
TRANSMISSION-	4-speed, synchro-mesh; shift lever on transmission; provision for power take-off on left side
VENTILATOR -----	Top of cowl
WHEELS-----	7; wide-base rim; 20 x 5.0
WINDSHIELD WIPERS	
4112 only -----	Dual; cowl mounted

**OPTIONAL EQUIPMENT**

For model application see Option Section

	Wt	Number	Wt	Number
AIR CLEANER: AC make, oil bath type				
1 pint capacity ----- *	216		40 amp ----- *	326
2 pint capacity ----- *	216		50 amp ----- *	326
AXLE, FRONT: Heavy Duty -----	37F	203	55 amp ----- 27F	326
AXLE, REAR: Single-speed, full-floating, 5.43 ratio; 11000 lb capacity ----- *	204		55 amp, low cut-in ----- 24F	326
AXLE, 2-SPEED REAR: Full-floating; 13000 lb capacity; hypoid primary gears			GOVERNOR: Range 2300-3200 RPM ---- *	241
6.13 and 8.10 ratios ----- 170R	243		OIL FILTER: AC make,	
BRAKE BOOSTER: (Hydraulic) Long stroke, 7 dia; vacuum-operated -----11F, 9R	212		1 quart capacity ----- 8F	237
COLORS, VEHICLE: Solid ----- *	234		2 quart capacity ----- 15F	237
CRANKCASE VENTILATION: Vac-operated with filtered air from oil bath air cleaner ---*	217		RADIATOR, HEAVY DUTY: 18 qt cap.-- *	256
ENGINE, HEAVY DUTY:			SHOCK ABSORBERS: Direct double-acting	
Loadmaster, 235.5 cu. in. displ			Front, 1-3/8 diameter piston ----- 16F	200
Gross HP, 112 @ 3700 RPM			Rear, 1-3/8 diameter piston ----- 24R	200
Gross Torque, 200 ft lb @ 2000 RPM--- *	225		SPRINGS, HEAVY DUTY:	
EQUIPMENT, HEAVY DUTY: To increase max. GVW from 11000 to 14000 lb, use the following group of options: 233, Heavy Duty Frame, 253, Front Springs: 267, Rear Springs: 212, Brake Booster and at least 7.00-20-8 pr Front and 7.50-20-8 pr Dual Rear Tires ----- 89F, 252R			Front, 8-leaf, 1900 lb (ea) capacity-- *	253
FRAME, HEAVY DUTY:			Rear, 11-leaf, two-stage; 5600 lb (ea) capacity at ground ----- *	268
Section modulus, 8.80 in. <sup>3</sup> ----- 20F, 23R	233		REAR AND AUXILIARY:	
GENERATOR: Including voltage and current regulator, and pulley for high output			Main, 11-leaf; Auxiliary, 6-leaf Capacity at ground (Main and Auxiliary)	
			7800 lb (ea) ----- 76R	267
			STARTER, SOLENOID (4102 only) ----- *	327
			TANK, VACUUM RESERVE: 1000 cu. in. capacity ----- 6F, 6R	281
			TIRES, MAXIMUM: Front and Dual Rear, 7.50-20-10pr; 2700 lb (ea) cap.- 88F, 186R	305
			VACUUM BOOSTER AND FUEL PUMP--- *	340
			WINDSHIELD WIPERS:	
			Dual, electric, 4112 only ----- *	320

\* - Weight is less than 10 pounds

10-29-54

**CHEVROLET 1955 SPECIFICATIONS—TRUCK**

**MODELS 4102 AND 4112 DATA-91**



CHASSIS AND BODY DIMENSIONS

Model 4103 Cab Chassis

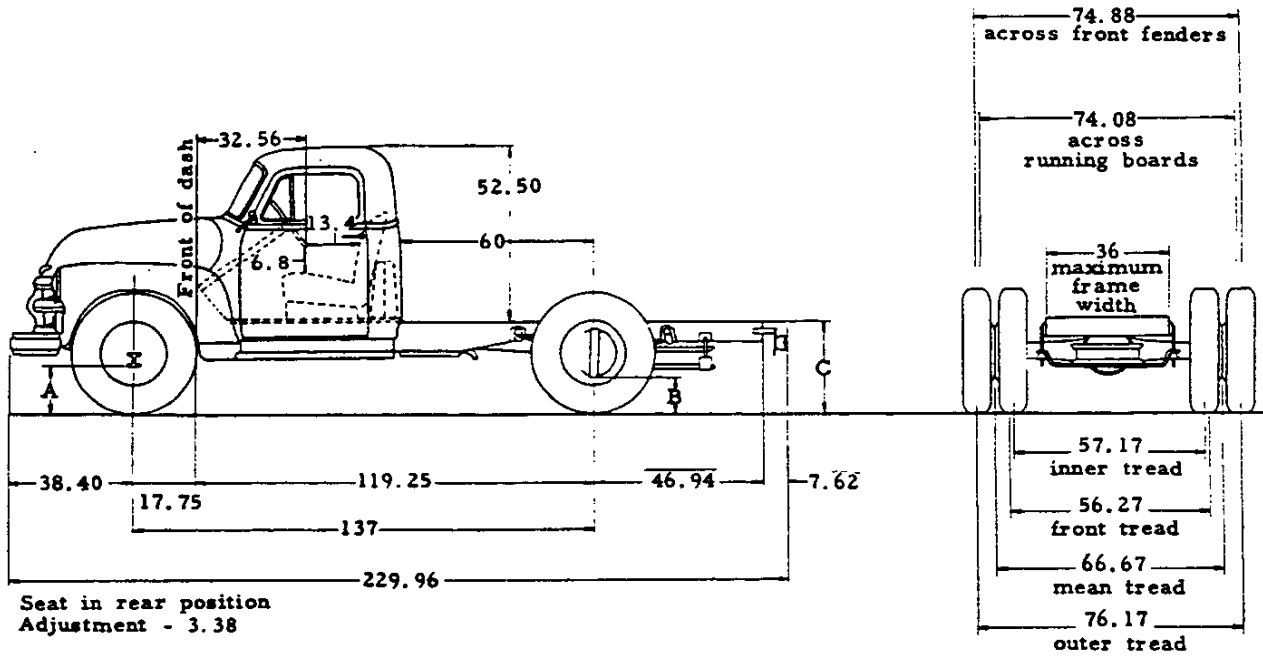

Equipment	Height Without Body and Payload		
	A	B	C
Standard	11.19	8.91	32.78
Minimum for Max GVW	11.69	10.22	34.70

To determine loaded and unloaded heights, body specifications must be known. Minimum tire equipment for Max GVW is 7.00-20-8pr front and 7.50-20-8pr dual rr.

VEHICLE WEIGHTS AND LOAD DISTRIBUTION

MODEL	WITH STANDARD EQUIPMENT						WITH MINIMUM EQUIPMENT FOR MAXIMUM GVW			
	Shipping			Curb			Body and Payload	Payload Distribution		Body Length
	Front	Rear	Total	Front	Rear	Total		Front	Rear	
4103	2285	1765	4050	2370	1870	4240	9450	7%	93%	96
								5%	95%	102
								3%	97%	108

10-29-54

92 - MODEL 4103 DATA

CHEVROLET 1955 SPECIFICATIONS—TRUCK

## MODEL 4103 HEAVY DUTY CAB CHASSIS

1-1/2 TON NOMINAL RATING---137 WHEELBASE---14000 lb MAXIMUM GVW

### STANDARD EQUIPMENT

<p>AIR CLEANER ----- AC make; oil-wetted type</p> <p>AXLE, FRONT ----- I-beam type; 4000 lb capacity</p> <p>AXLE, REAR ----- Full-floating type; 11000 lb capacity; Hypoid gears; 6.17 ratio</p> <p>BATTERY ----- 15 plate; 100 amp hr capacity</p> <p>BRAKES</p> <p style="padding-left: 20px;">PARKING ----- Hand-operated on prop shaft; 35 sq. in. area</p> <p style="padding-left: 20px;">SERVICE ----- Hydraulic type; 4-wheel; 375 sq. in.</p> <p style="padding-left: 40px;">FRONT ----- 14 x 2-1/2; 134 sq. in. area</p> <p style="padding-left: 40px;">REAR ----- 15 x 4; 241 sq. in. area</p> <p>BUMPER, FRONT ----- Rigid, channel-type; painted</p> <p>CAB ----- All-steel; welded; flexibly mounted</p> <p>CLUTCH ----- Diaphragm spring; single disc type; 11 dia; 123.7 sq. in. area; 282 ft lb capacity</p> <p>COLOR, BASIC VEHICLE ----- Juniper Green</p> <p>COOLING SYSTEM ----- Cellular radiator core, 4 lb press. cap; 407 sq. in. frontal area; 17 quart capacity</p> <p>DISPATCH BOX ----- 13-1/2 x 5-1/2 x 8-1/2</p> <p>DOME LIGHT ----- Above rear window</p> <p>DRIVE SYSTEM ----- Hotchkiss</p> <p>ENGINE ----- Thriftmaster; 235.5 cu. in. displ</p> <p>GROSS HP ----- 112 @ 3700 RPM</p> <p>GROSS TORQUE ----- 200 ft lb @ 2000 RPM</p> <p>FENDERS ----- Front only</p> <p>FRAME ----- Ladder type with 5 cross members, channel side rails 7 x 2-3/4 x 7/32; section modulus 5.52 in.<sup>3</sup></p>	<p>FUEL TANK ----- Back of seat in cab; 17-1/2 gal. cap.</p> <p>GENERATOR ----- 45 amp maximum rate</p> <p>LIGHTS ----- 2 head, 2 parking, and 1 tail and stop</p> <p>MIRROR, REAR VIEW ----- LH; long adjustable bracket</p> <p>RUNNING BOARDS ----- Short</p> <p>SEAT ----- Full width</p> <p>SPARE WHEEL CARRIER ----- Underslung at rear</p> <p>SPRINGS</p> <p style="padding-left: 20px;">FRONT ----- Semi-elliptic; 7-leaf, 40 x 2; 1740 lb (ea) capacity at ground</p> <p style="padding-left: 20px;">REAR ----- Semi-elliptic; 11-leaf, 46 x 2-1/2; 4465 lb. (ea) capacity at ground</p> <p>STEERING GEAR ----- Recirculating-ball type; 26.24 ratio; 18-inch dia wheel</p> <p>SUNSHADE ----- Adjustable; for driver</p> <p>TIRES ----- Front and dual rear; 6.50-20-6p.; 1700 lb (ea) cap.</p> <p>TOOLS ----- 8250 lb capacity jack; tire changing iron; wheel wrench</p> <p>TOOL BOX ----- Under seat; 50 x 19 x 6</p> <p>TRANSMISSION ----- 4-speed synchro-mesh; shift lever on transmission; provision for power take-off on left side</p> <p>VENTILATORS ----- Top of cowl and ventipanes</p> <p>WHEELS ----- 7; wide-base rim; 20 x 5.0</p> <p>WINDSHIELD WIPERS ----- Dual; cowl mounted</p>
---	--

### OPTIONAL EQUIPMENT

For model application see Option Section

	Wt	Number		Wt	Number
AIR CLEANER: AC make, oil bath type			regulator, and pulley for high output		
(2 pint capacity standard equipment			40 amp -----	*	326
on heavy duty engine RPO)			50 amp -----	*	326
1 pint capacity -----	*	216	55 amp -----	27F	326
2 pint capacity -----	*	216	55 amp, low cut-in -----	24F	326
AXLE, FRONT: Heavy Duty -----	37F	203	GLASS EQUIPMENT, BODY: Tinted -----	*	399
AXLE, REAR: Single-speed, full-floating;			GOVERNOR: Range, 2300-3200 RPM -----	*	241
5.43 ratio; 11000 lb capacity -----	*	204	MIRROR, REAR VIEW:		
AXLE, 2-SPEED REAR: Full-floating, 13000 lb			Long, RH or Short, LH -----	*	210
capacity; hypoid primary gears			OIL FILTER: AC, 1 quart capacity -----	8F	237
6.13 & 8.10 ratios -----	170R	243	2 quart capacity -----	15F	237
BRAKE BOOSTER (Hydraulic) Long stroke,			RADIATOR, HEAVY DUTY: 18 qt cap. -----	*	256
7 diameter; vacuum-operated -----	11F, 9R	212	SEAT EQUIPMENT: Unison -----	*	264
COLORS, VEHICLE: Solid -----	*	234	SHOCK ABSORBERS: Direct double-acting type:		
CORNER WINDOWS, CAB: Clear or tinted -----	*	387	Front, 1-3/8 dia piston -----	16F	200
CRANKCASE VENTILATION: Vac-operated with			Rear, 1-3/8 dia piston -----	24R	200
filtered air from oil bath air cleaner -----	217		SIDE DOOR, KEY LOCK: Left hand -----	*	395
ENGINE, HEAVY DUTY:			SPRINGS, HEAVY DUTY:		
Loadmaster, 235.5 cu. in. displ			Front, 8-leaf; 1900 lb (ea) capacity -----	*	253
Gross HP - 112 @ 3700 RPM			Rear, 11-leaf; two-stage, 5600 lb (ea)		
Gross torque - 200ft lb @ 2000 RPM -----	*	225	capacity at ground -----	*	268
EQUIPMENT, HEAVY DUTY: To increase			Rear and Auxiliary: Main 11-leaf,		
max. GVW from 11000 to 14000 lb, use			Auxiliary 6-leaf: capacity at ground		
the following group of options: 233 heavy			(Main and Auxiliary) 7800 lb (ea) ---	76R	267
duty frame; 253, front springs; 267 rear springs			TANK, VACUUM RESERVE: 1000 cu. in.		
212 brake booster; and at least 7 00-20-8pr front			capacity -----	6F, 6R	281
and 7.50-20-8pr dual rear tires 89F, 252R			TIRES, MAXIMUM: Front & Dual Rear;		
FRAME, HEAVY DUTY:			7.50-20-10pr; 2700 lb (ea) cap. ---	88F, 186R	305
Section modulus; 8.80 in. <sup>3</sup> -----	20F, 23R	233	VACUUM BOOSTER AND FUEL PUMP -----	*	340
GENERATOR: Including voltage and current			WINDSHIELD WIPERS: Dual, Electric -----	*	320

\* - Weight is less than 10 pounds

10-29-54

**CHEVROLET 1955 SPECIFICATIONS—TRUCK**

**MODEL 4103 DATA- 93**

CHASSIS AND BODY DIMENSIONS

Model 4108 Platform Truck

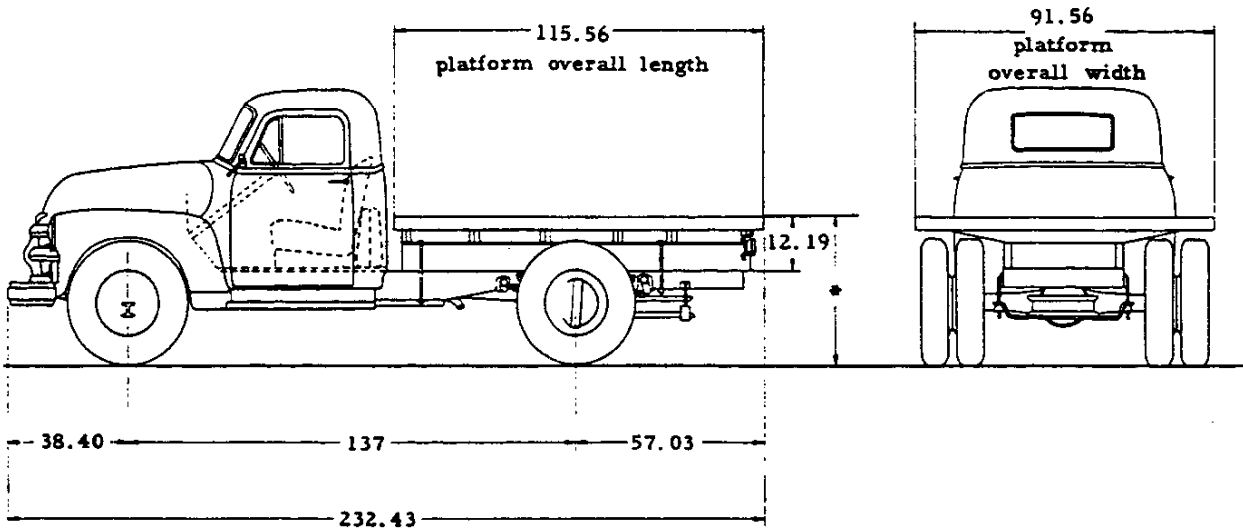

Equipment	*Platform Height		Tires	
	Loaded	Unloaded	Front	Rear
Standard	42.06	45.07	6.50-20-6pr	6.50-20-6pr dual
Minimum for Max GVW	43.31	47.08	7.00-20-8pr	7.50-20-8pr dual

Model 4109 Stake Truck

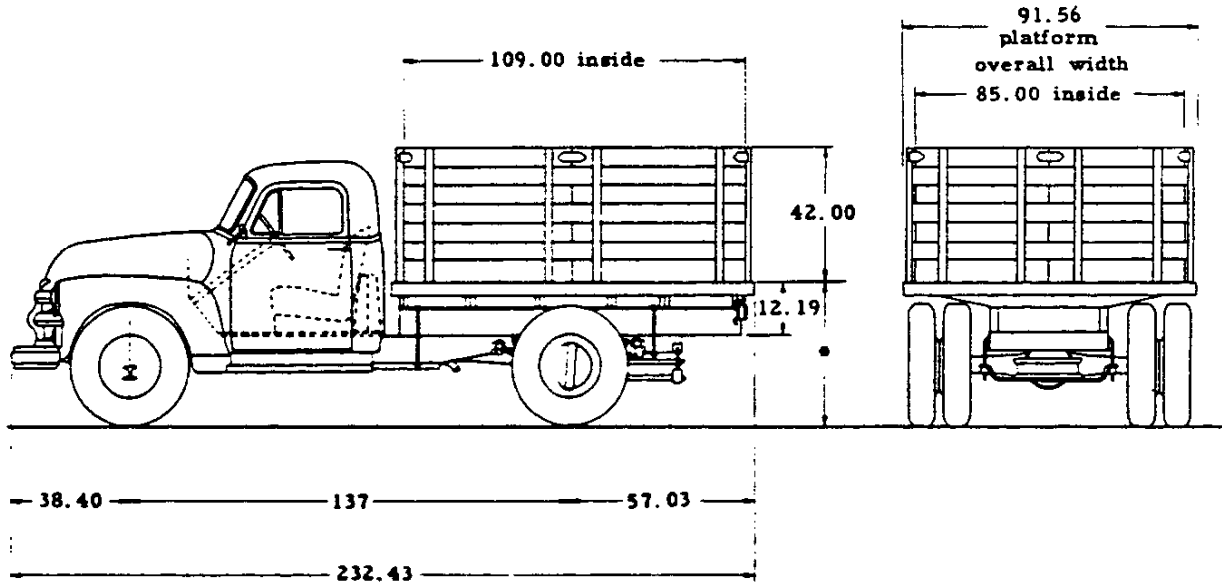

Equipment	*Platform Height		Tires	
	Loaded	Unloaded	Front	Rear
Standard	42.06	45.00	6.50-20-6pr	6.50-20-6pr dual
Minimum for Max GVW	43.19	46.92	7.00-20-8pr	7.50-20-8pr dual

VEHICLE WEIGHTS AND LOAD DISTRIBUTION

MODEL	WITH STANDARD EQUIPMENT						WITH MINIMUM EQUIPMENT FOR MAXIMUM GVW			
	Shipping			Curb			Body and Payload	Payload Distribution		Body Length
	Front	Rear	Total	Front	Rear	Total		Front	Rear	
4108⊙	2300	2270	4570	2380	2475	4855	8950	0%	100%	115.66
4109	2295	2570	4865	2380	2675	5055	8650	1%	99%	109.00

⊙ - Estimated Weight

10-29-54

94-MODELS 4108 AND 4109 DATA

CHEVROLET 1955 SPECIFICATIONS—TRUCK

**MODEL 4108 HEAVY DUTY PLATFORM TRUCK  
MODEL 4109 HEAVY DUTY STAKE TRUCK**

1-1/2 TON NOMINAL RATING --- 137 WHEELBASE --- 14000 lb MAXIMUM GVW

**STANDARD EQUIPMENT**

AIR CLEANER ----- AC make; oil-wetted type	FENDERS ----- Front only
AXLE, FRONT ----- I-beam type; 4000 lb capacity	FRAME ----- Ladder type with 5 cross members channel side rails 7 x 2-3/4 x 7/32; section modulus 5.52 in. <sup>3</sup>
AXLE, REAR ----- Full-floating type; 11000 lb capacity; hypoid gears; 6.17 ratio	FUEL TANK ----- Back of seat in cab; 17-1/2 gal cap.
BATTERY ----- 15 plate; 100 amp hr capacity	GENERATOR ----- 45 amp maximum rate
BODY--Nominal 9-foot wood platform body with steel skid strips. Steel cross sills, and full length wood side sills. Entire platform is bound by a steel channel-type rub rail with stake pockets integrally formed. 4109 is equipped with 42" high stake rack.	LIGHTS ----- 2 Head, 2 Parking, and 1 Tail and Stop
BRAKES	MIRROR, REAR VIEW---- LH; long adjustable bracket
PARKING----Hand-operated on prop shaft, 35 sq. in.	RUNNING BOARDS----- Short
SERVICE---Hydraulic type; 4-wheel; 375 sq. in. area	SEAT-----Full width
FRONT-----14 x 2-1/2; 134 sq. in. area	SPARE WHEEL CARRIER----- Underslung at rear
REAR ----- 15 x 4; 241 sq. in. area	SPRINGS
BUMPER, FRONT-----Rigid, channel-type; painted	FRONT----- Semi-elliptic; 7-leaf, 40 x 2; 1740 lb (ea) capacity at ground
CAB----- All-steel; welded; flexibly mounted	REAR ----- Semi-elliptic; 11-leaf, 46 x 2-1/2; 4465 lb (ea) capacity at ground
CLUTCH --Diaphragm spring, single disc type; 11 dia; 123.7 sq. in. area; 282 ft lb capacity	STEERING GEAR ----- Recirculating-ball type; 26.24 ratio; 18 dia wheel
COLOR, BASIC VEHICLE ----- Juniper Green	SUNSHADE----- Adjustable; for driver
COOLING SYSTEM-----Cellular radiator core, 4 lb press. cap; 407 sq. in. frontal area; 17 quart capacity	TIRES ----- Front and Dual Rear; 6.50-20-6pr; 1700 lb (ea) capacity
DISPATCH BOX ----- 13-1/2 x 5-1/2 x 8-1/2	TOOLS ----- 8250 lb capacity jack; tire changing iron; wheel wrench
DOME LIGHT ----- Above rear window	TOOL BOX ----- Under seat; 50 x 19 x 6
DRIVE SYSTEM ----- Hotchkiss	TRANSMISSION - 4-Speed, Synchro-mesh; shift lever on transmission; provision for power take-off on left side
ENGINE----- Thriftmaster; 235.5 cu. in. displ	VENTILATORS ----- Top of cowl and ventipanes
GROSS HP ----- 112 @ 3700 RPM	WHEELS ----- 7; wide base rim; 20 x 5.0
GROSS TORQUE ----- 200 ft lb @ 2000 RPM	WINDSHIELD WIPERS ----- Dual; cowl mounted

**OPTIONAL EQUIPMENT**

For model application see Option Section

	Wt	Number	Wt	Number
AIR CLEANER: AC make; oil bath type			40 amp ----- *	326
(2 pt cap. standard equip. on heavy duty engine RPO)			50 amp ----- *	326
1 pint capacity ----- *	216		55 amp----- 27F	326
2 pint capacity ----- *	216		55 amp, low cut-in ----- 24F	326
AXLE, FRONT: Heavy Duty ----- 37F	203		<b>GLASS EQUIPMENT, BODY:</b>	
AXLE, REAR: Single-speed, full-floating;			Tinted ----- *	399
5.43 ratio; 11000 lb capacity ----- *	204		GOVERNOR: Range 2300-3200 RPM ----- *	241
AXLE, 2-SPEED REAR: Full-floating; 13000 lb			MIRROR, REAR VIEW: Long RH ----- *	210
capacity; hypoid primary gears			OIL FILTER: AC make,	
6.13 and 8.10 ratios ----- 170R	243		1 quart capacity ----- 8F	237
BRAKE BOOSTER (Hydraulic) -- Long stroke:			2 quart capacity ----- 15F	237
7 dia; vacuum-operated ----- 11F, 9R	212		RADIATOR, HEAVY DUTY: 18 qt cap. --- *	256
COLORS, VEHICLE: Solid ----- *	234		SEAT EQUIPMENT: Unison ----- *	264
CORNER WINDOWS, CAB: Clear or tinted *	387		SHOCK ABSORBERS: Direct double-acting type;	
CRANKCASE VENTILATION: Vac-operated with			Front 1-3/8 diameter piston ----- 16F	200
filtered air from oil bath air cleaner --- *	217		Rear 1-3/8 diameter piston ----- 24R	200
ENGINE, HEAVY DUTY:			SIDE DOOR KEY LOCK, LH ----- *	395
Loadmaster, 235.5 cu. in. displ			SPRINGS, HEAVY DUTY:	
Gross HP, 112 @ 3700 RPM			Front, 8-leaf; 1900 lb (ea) capacity --- *	253
Gross torque, 200 ft lb @ 2000 RPM --- *	225		Rear, 11-leaf; two-stage, 5600 lb (ea) capacity at ground ----- *	268
EQUIPMENT, HEAVY DUTY: To increase max			REAR AND AUXILIARY: Main 11-leaf, Auxiliary, 6-leaf, capacity at ground (Main and Auxiliary) 7800 lb (ea) ---- 76R	267
GVW from 11000 to 14000 lb, use the following			TANK, VACUUM RESERVE:	
group of options: 233, Heavy Duty Frame, 253,			1000 cu. in. capacity ----- 6F, 6R	281
Front Springs; 267, Rear Springs; 212, Brake Booster			TIRES MAXIMUM: Front and Dual Rear, 7.50-20-10pr; 2700 lb (ea) cap.--84F, 186R	305
and at least 7.00-20-8pr Front, and 7.50-20-8pr			VACUUM BOOSTER AND FUEL PUMP -- *	340
Dual Rear Tires ----- 89F, 252R			WINDSHIELD WIPERS: Dual, Electric --- *	320
FRAME, HEAVY DUTY:				
Section modulus, 8.80 in. <sup>3</sup> ----- 20F, 23R	233			
GENERATOR: With voltage and current				
regulator, and pulley for high output				

\* - Weight is less than 10 pounds

CHASSIS AND BODY DIMENSIONS

Model 4402 Flat Face Cowl Chassis  
 Model 4412 Windshield Cowl Chassis

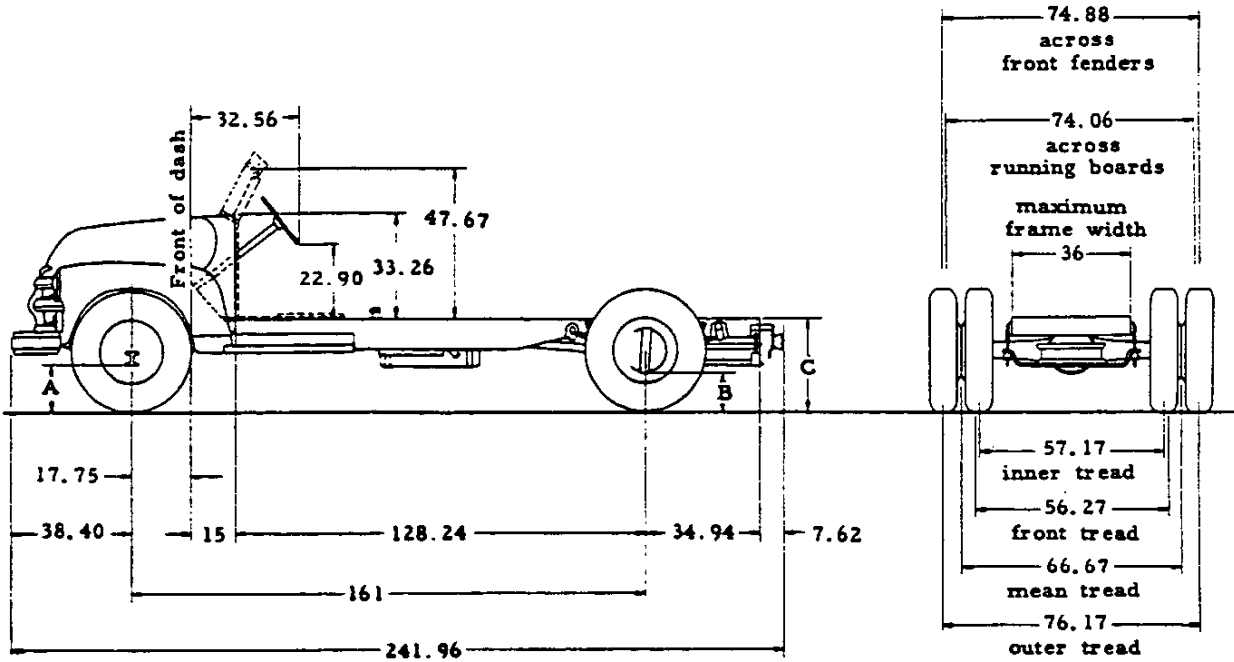

Equipment	Height Without Body and Payload		
	A	B	C
Standard	11.19	8.94	32.75
Minimum for Max GVW	11.69	10.24	34.00

To determine loaded and unloaded heights, body specifications must be known. Minimum tire equipment for Max GVW is 7.00-20-8pr front and 7.50-20-8pr dual rr.

VEHICLE WEIGHTS AND LOAD DISTRIBUTION

MODEL	WITH STANDARD EQUIPMENT						WITH MINIMUM EQUIPMENT FOR MAXIMUM GVW			
	Shipping			Curb			Body and Payload	Payload Distribution		Body Length
	Front	Rear	Total	Front	Rear	Total		Front	Rear	
4402	2115	1620	3735	2170	1755	3925	9800	Determined by style, length and weight of body.		
4412	2230	1620	3850	2285	1755	4040				9700

Ø - Estimated weights

10-29-54

96 - MODELS 4402 AND 4412 DATA

CHEVROLET 1953 SPECIFICATIONS—TRUCK

**MODEL 4402 HEAVY DUTY FLAT FACE COWL CHASSIS  
MODEL 4412 WINDSHIELD COWL CHASSIS**

1-1/2 TON NOMINAL RATING --- 161 WHEELBASE --- 14000 lb MAXIMUM GVW

STANDARD EQUIPMENT		EQUIPMENT	
AIR CLEANER -----	AC make; oil-wetted type	GENERATOR -----	45 amp maximum rate
AXLE, FRONT -----	I-beam; 4000 lb capacity;	LIGHTS -----	2 head, 2 parking, and 1 tail and stop
AXLE, REAR -----	Full-floating; 11000 lb capacity; Hypoid gears; 6.17 ratio	RUNNING BOARDS -----	Short
BATTERY -----	15 plate; 100 amp hr capacity	SEAT RISER -----	4412 only
BRAKES		SPARE WHEEL CARRIER -----	Underslung at rear
PARKING -----	Hand-operated on prop shaft; 35 sq. in. area	SPRINGS	
SERVICE -----	Hydraulic type; 4-wheel; 375 sq. in.	FRONT -----	Semi-elliptic; 7-leaf, 40 x 2; 1740 lb (ea) capacity at ground
FRONT -----	14 x 2-1/2; 134 sq. in. area	REAR -----	Semi-elliptic; 11-leaf, 46 x 2-1/2; 4465 lb (ea) capacity at ground
REAR -----	15 x 4; 241 sq. in. area	STEERING GEAR -----	Recirculating-ball type; 26.24 ratio; 18-inch dia wheel
BUMPER, FRONT -----	Rigid, channel-type; painted	TIRES -----	Front and dual rear; 6.50-20-6pr; 1700 lb (ea) cap.
CLUTCH--Diaphragm spring; single disc type; 11 dia 123.7 sq. in. area; 282 ft lb capacity		TOOLS-----	8250 lb capacity jack; tire changing iron; wheel wrench
COLOR, BASIC VEHICLE -----	Juniper Green	TOOL BOX (4412 only) -----	50 x 19 x 2-3/8
COOLING SYSTEM -----	Cellular radiator core, 4 lb press. cap; 407 sq. in. frontal area; 17 quart capacity	TRANSMISSION -----	4-speed, synchro-mesh; shift lever on trans; provision for power take-off on left side
DISPATCH BOX --- 4402 -- 13-7/8 x 4-3/4 x 8-1/4; 4412 -- 13-1/2 x 5-1/2 x 8-1/2;		VENTILATOR -----	Top of cowl
DRIVE SYSTEM -----	Hotchkiss	WHEELS -----	7; wide-base rim; 20 x 5.0
ENGINE -----	Thriftmaster; 235.5 cu. in. displ	WINDSHIELD WIPERS	
GROSS HP -----	112 @ 3700 RPM	4412 only -----	Dual; cowl mounted
GROSS TORQUE -----	200 ft lb @ 2000 RPM		
FENDERS-----	Front only		
FRAME -----	Ladder type with 6 cross members channel side rails 8-7/8 x 2-7/8 x 1/4; section modulus 8.80 in. <sup>3</sup>		
FUEL TANK -Outside of frame on right side; 18 gal cap.			

**OPTIONAL EQUIPMENT**

For model application see Option Section

	Wt	Number		Wt	Number
AIR CLEANER: AC make, oil bath type			40 amp -----	*	326
(2 pt cap. std equip. on heavy duty engine RPO)			50 amp -----	*	326
1 pint capacity -----	216		55 amp -----	27F	326
2 pint capacity -----	216		55 amp, low cut-in -----	24F	326
AXLE, FRONT: Heavy Duty -----	37F	203	GOVERNOR: Range, 2300-3200 RPM ----	*	241
AXLE, REAR: Single-speed, Full-Floating; 5.43 ratio; 11000 lb capacity -----	*	204	OIL FILTER: AC make		
AXLE, 2-SPEED REAR: Full-floating; 13000 lb capacity; hypoid primary gears			1 quart capacity -----	8F	237
6.13 & 8.10 ratios -----	170R	243	2 quart capacity -----	15F	237
BRAKE BOOSTER: (Hydraulic) Long stroke, 7 diameter; vacuum-operated -----	11F, 9R	212	RADIATOR, HEAVY DUTY: 18 qt cap. ----	*	256
COLORS, VEHICLE: Solid -----	*	234	SHOCK ABSORBERS: Direct double-acting;		
CRANKCASE VENTILATION: Vac-operated with filtered air from oil bath air cleaner ---	*	217	Front, 1-3/8 diameter piston -----	16F	200
ENGINE, HEAVY DUTY:			Rear, 1-3/8 diameter piston -----	24R	200
Loadmaster 235.5 cu. in. displ			SPRINGS, HEAVY DUTY:		
Gross HP - 112 @ 3700 RPM			Front, 8-leaf; 1900 lb (ea) capacity ----	*	253
Gross torque - 200 ft lb @ 2000 RPM ---	*	225	Rear, 11-leaf; two-stage, 5600 lb (ea) capacity at ground -----	*	268
EQUIPMENT, HEAVY DUTY: To increase max. GVW from 11000 to 14000 lb, use the following group of options: 253, Front Springs; 267, Rear Springs; 212 Brake Booster; and at least 7.00-20-8pr Front, and 7.50-20-8pr Dual Rear Tires -- 69F, 229R			REAR AND AUXILIARY:		
GENERATOR: Including voltage and current regulator, and pulley for high output			Main, 11-leaf; Auxiliary, 6-leaf capacity at ground (Main and Auxiliary) 7800 lb (each) -----	76R	267
			TANK, VACUUM RESERVE(1000cu.in.)-6F, 6R		231
			TIRES, MAXIMUM:		
			Front and Dual Rear, 7.50-20-10pr; 2700 lb (ea) capacity -----	88F, 186R	305
			VACUUM BOOSTER AND FUEL PUMP ---	*	340
			WINDSHIELD WIPERS:		
			Dual, Electric (4412 only) -----	*	320

\* - Weight is less than 10 pounds

10-29-54

**CHEVROLET 1955 SPECIFICATIONS—TRUCK**

**MODELS 4402 AND 4412 DATA-97**

CHASSIS AND BODY DIMENSIONS

Model 4403 Cab Chassis

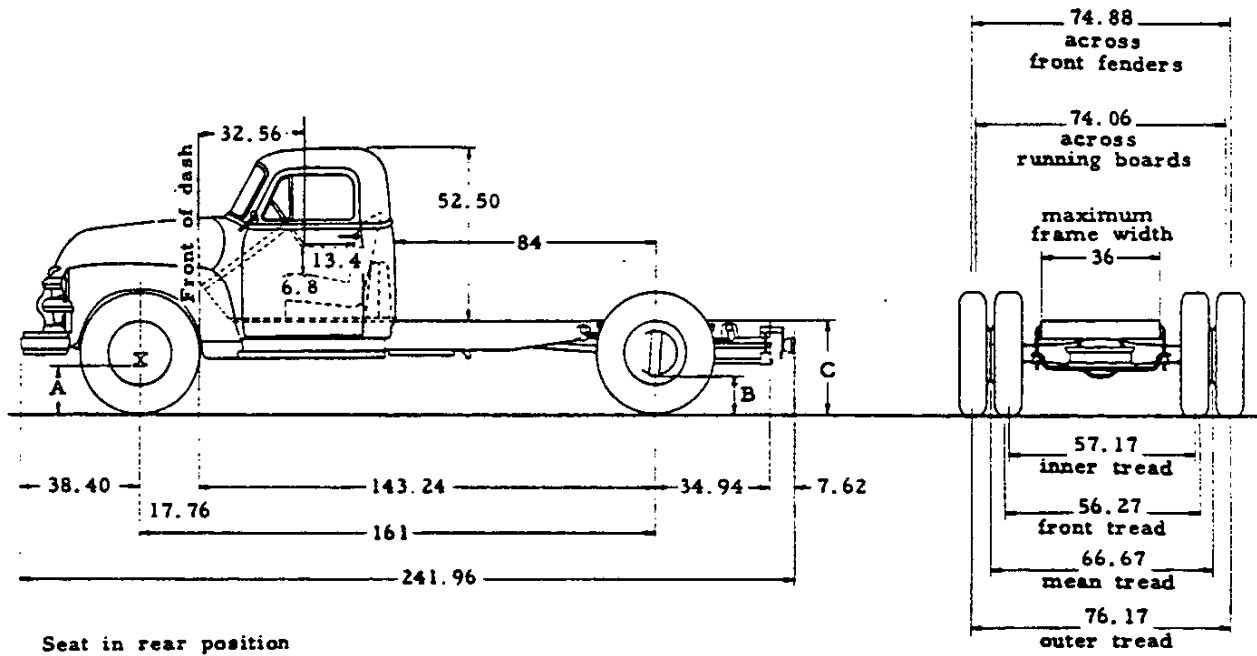

Seat in rear position  
Adjustment - 3.38

Equipment	Height Without Body and Payload		
	A	B	C
Standard	11.13	8.94	32.79
Minimum for Max GVW	11.71	10.24	34.00

To determine loaded and unloaded heights, body specifications must be known. Minimum tire equipment for Max GVW is 7.00-20-8pr front and 7.50-20-8pr dual rr.

VEHICLE WEIGHTS AND LOAD DISTRIBUTION

MODEL	WITH STANDARD EQUIPMENT						WITH MINIMUM EQUIPMENT FOR MAXIMUM GVW			
	Shipping			Curb			Body and Payload	Payload Distribution		Body Length
	Front	Rear	Total	Front	Rear	Total		Front	Rear	
4403	2390	1790	4180	2490	1880	4370	9350	14%	86%	120
								10%	90%	132
								6%	94%	144

10-29-54

98 - MODEL 4403 DATA

CHEVROLET 1955 SPECIFICATIONS—TRUCK

## MODEL 4403 HEAVY DUTY CAB CHASSIS

1-1/2 TON NOMINAL RATING---161 WHEELBASE---14000 lb MAXIMUM GVW

### STANDARD EQUIPMENT

<p>AIR CLEANER-----AC make; oil-wetted type</p> <p>AXLE, FRONT-----I-beam type; 4000 lb capacity</p> <p>AXLE, REAR----- Full-floating type; 11000 lb capacity; Hypoid gears; 6.17 ratio</p> <p>BATTERY----- 15 plate; 100 amp hr capacity</p> <p>BRAKES</p> <p style="padding-left: 20px;">PARKING-----Hand-operated on prop shaft; 35 sq. in.</p> <p style="padding-left: 20px;">SERVICE-----Hydraulic type; 4-wheel; 375 sq. in.</p> <p style="padding-left: 40px;">FRONT-----14 x 2-1/2; 134 sq. in. area</p> <p style="padding-left: 40px;">REAR-----15 x 4; 241 sq. in. area</p> <p>BUMPER, FRONT-----Rigid, channel-type; painted</p> <p>CAB-----All-steel; welded; flexibly mounted</p> <p>CLUTCH---Diaphragm spring; single disc type; 11 dia; 123.7 sq. in. area; 282 ft lb capacity</p> <p>COLOR, BASIC VEHICLE----- Juniper Green</p> <p>COOLING SYSTEM ---- Cellular radiator core, 4 lb press. cap; 407 sq. in. frontal area; 17 quart capacity</p> <p>DISPATCH BOX----- 13-1/2 x 5-1/2 x 8-1/2</p> <p>DOMELIGHT----- Above rear window</p> <p>DRIVE SYSTEM----- Hotchkiss</p> <p>ENGINE-----Thriftmaster; 235.5 cu. in. displ</p> <p style="padding-left: 20px;">GROSS HP----- 112 @ 3700 RPM</p> <p style="padding-left: 20px;">GROSS TORQUE----- 200 ft lb @ 2000 RPM</p> <p>FENDERS----- Front only</p> <p>FRAME----- Ladder type with 6 cross members, channel side rails 8-7/8 x 2-7/8 x 1/4; section modulus 8.80 in<sup>3</sup></p>	<p>FUEL TANK----- Back of seat in cab; 17-1/2 gal capacity</p> <p>GENERATOR----- 45 amperes max rate</p> <p>LIGHTS-----2 head, 2 parking, and 1 tail and stop</p> <p>MIRROR, REAR VIEW---- LH; long adjustable bracket</p> <p>RUNNING BOARDS----- Short</p> <p>SEAT-----Full width</p> <p>SPARE WHEEL CARRIER----- Underslung at rear</p> <p>SPRINGS</p> <p style="padding-left: 20px;">FRONT----- Semi-elliptic; 7-leaf, 40 x 2; 1740 lb (ea) capacity at ground</p> <p style="padding-left: 20px;">REAR----- Semi-elliptic; 11-leaf, 46 x 2-1/2; 4465 lb (ea) capacity at ground</p> <p>STEERING GEAR----- Recirculating-ball type; 26.24 ratio; 18-inch dia wheel</p> <p>SUNSHADE----- Adjustable; for driver</p> <p>TIRES----- Front and dual rear; 6.50-20-6 pr; 1700 lb (ea) capacity</p> <p>TOOLS----- 8250 lb capacity jack; tire changing iron; wheel wrench</p> <p>TOOL BOX----- Under seat; 50 x 19 x 6</p> <p>TRANSMISSION--- 4-speed, synchro-mesh; shift lever on transmission; provision for power take-off on left side</p> <p>VENTILATORS----- Top of cowl and ventipanes</p> <p>WHEELS----- 7; wide-base rim; 20 x 5.0</p> <p>WINDSHIELD WIPERS----- Dual; cowl mounted</p>
--	---

### OPTIONAL EQUIPMENT

For model application see Option Section

	Wt	Number		Wt	Number
AIR CLEANER: AC make, oil bath type			55 amp -----	27F	326
(2 pt cap. standard equip. on heavy duty engine RPO)			55 amp, low cut-in -----	24F	326
1 pint capacity -----*	216		GLASS EQUIPMENT, BODY: Tinted ----- *		399
2 pint capacity -----*	216		GOVERNOR:		
AXLE, FRONT: Heavy Duty -----	37F	203	Range 2300-3200 RPM -----*		241
AXLE, REAR: Single-speed; full-floating;			MIRROR, REAR VIEW: Long, RH;		
5.43 ratio; 11000 lb capacity -----*	204		Short, RH or LH -----*		210
AXLE, 2-SPEED REAR: Full-floating; 13000 lb			OIL FILTER: AC make		
capacity; hypoid primary gears			1 quart capacity -----	8F	237
6.13 & 8.10 ratios -----	170R	243	2 quart capacity -----	15F	237
BRAKE BOOSTER (Hydraulic) long stroke,			RADIATOR, HEAVY DUTY: 18 qt cap. --- *		256
7 diameter; vacuum-operated ---- 11F, 9R	212		SEAT EQUIPMENT: Unison ----- *		264
COLORS, VEHICLE: Solid ----- *	234		SHOCK ABSORBERS: Direct double-acting		
CORNER WINDOWS, CAB: ----- *	387		Front, 1-3/8 diameter piston -----	16F	200
CRANKCASE VENTILATION: Vac-operated with			Rear, 1-3/8 diameter piston -----	24R	200
filtered air from oil bath air cleaner--- *	217		SIDE DOOR KEY LOCK, LH ----- *		395
ENGINE, HEAVY-DUTY:			SPRINGS, HEAVY DUTY:		
Loadmaster, 235.5 cu. in. displ			Front, 8-leaf; 1900 lb (ea) cap. -----*		253
Gross HP, 112 @ 3700 RPM			Rear, 11-leaf; two-stage, 5600 lb (ea)		
Gross torque, 200 ft lb @ 2000 RPM --- *	225		capacity at ground ----- *		268
EQUIPMENT, HEAVY DUTY: To increase			REAR AUXILIARY:		
max. GVW from 11000 to 14000 lb, use			Main, 11-leaf		
the following group of options; 253, Front			Auxiliary, 6-leaf		
Springs; 267; Rear Springs; 212 Brake			Capacity at ground (Main and Auxiliary)		
Booster; and at least 7.00-20-8pr Front and			7800 lb (ea) capacity -----	76R	267
7.50-20-8pr Dual Rear Tires -- 49F, 229R			TANK, VACUUM RESERVE: 1000cu. in. -6F, 6R		281
GENERATOR: Including voltage and current			TIRES, MAXIMUM: Front and Dual Rear		
regular, and pulley for high output			7.50-20-10pr; 2700 lb (ea) cap. --- 88F, 186R		305
40 amp ----- *	326		VACUUM BOOSTER AND FUEL PUMP --- *		340
50 amp ----- *	326		WINDSHIELD WIPERS: Dual, Electric --- *		320

\* - Weight is less than 10 pounds

10-29-54



CHASSIS AND BODY DIMENSIONS

Model 4408 Platform Truck

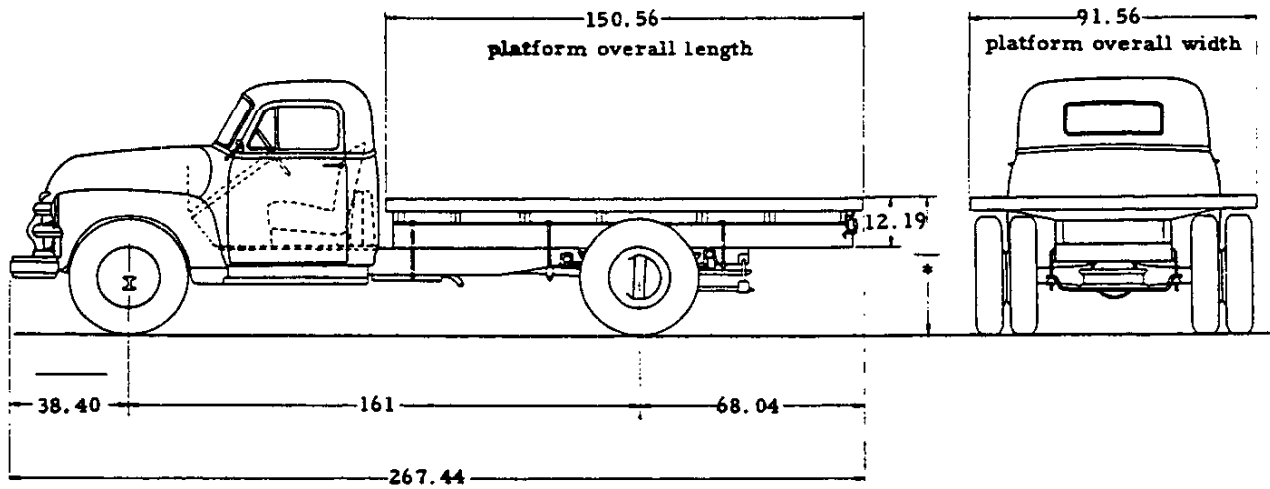

Equipment	*Platform Height		Tires	
	Loaded	Unloaded	Front	Rear
Standard	43.11	45.82	6.50-20-6pr	6.50-20-6pr dual
Minimum for Max GVW	44.07	47.03	7.00-20-8pr	7.50-20-8pr dual

Model 4409 Stake Truck

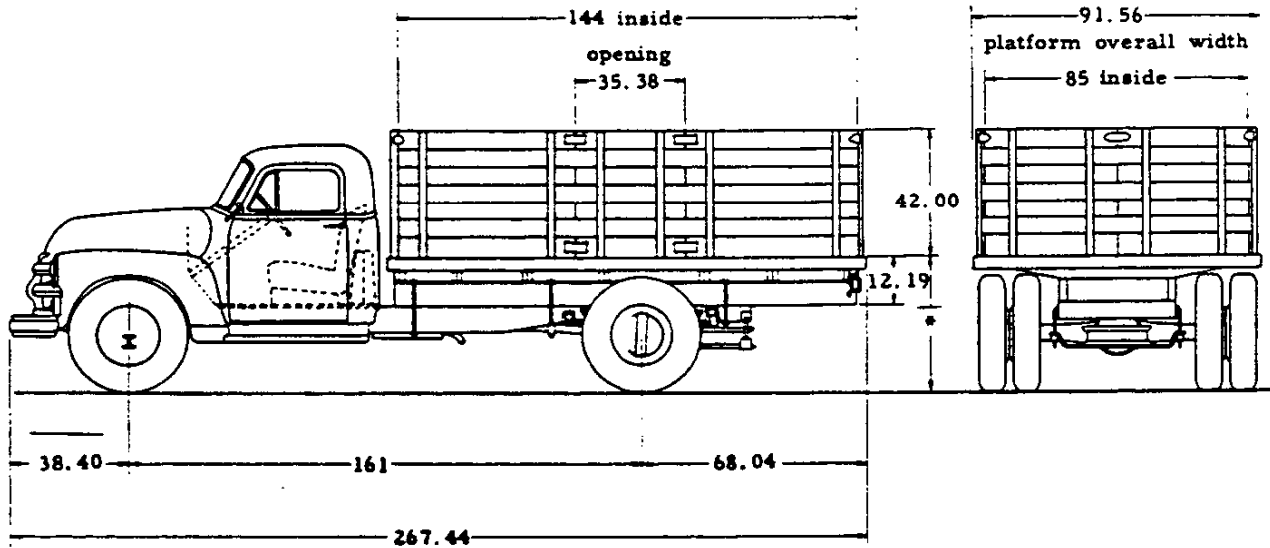

Equipment	*Platform Height		Tires	
	Loaded	Unloaded	Front	Rear
Standard	43.11	45.65	6.50-20-6pr	6.50-20-6pr dual
Minimum for Max GVW	44.07	46.84	7.00-20-8pr	7.50-20-8pr dual

VEHICLE WEIGHTS AND LOAD DISTRIBUTION

MODEL	WITH STANDARD EQUIPMENT						WITH MINIMUM EQUIPMENT FOR MAXIMUM GVW			
	Shipping			Curb			Payload	Payload Distribution		Body Length
	Front	Rear	Total	Front	Rear	Total		Front	Rear	
4408	2410	2490	4900	2510	2580	5090	8650	4%	96%	150.56
4409	2495	2750	5245	2595	2840	5435	8300	5%	95%	144.00

10-29-54

100-MODELS 4408, 4409 DATA

CHEVROLET 1955 SPECIFICATIONS—TRUCK

**MODEL 4408 HEAVY DUTY PLATFORM TRUCK  
MODEL 4409 HEAVY DUTY STAKE TRUCK**

1-1/2 TON NOMINAL RATING --- 161 WHEELBASE --- 14000 lb MAXIMUM GVW  
STANDARD EQUIPMENT

AIR CLEANER ----- AC make; oil-wetted type	FENDERS ----- Front only
AXLE, FRONT ----- I-beam type; 4000 lb capacity	FRAME ----- Ladder type with 6 cross members, channel side rails 8-7/8 x 2-7/8 x 1/4; section modulus, 8.80 in. <sup>3</sup>
AXLE, REAR ----- Full-floating type; 11000 lb capacity; Hypoid gears; 6.17 ratio	FUEL TANK ----- Back of seat in cab; 17-1/2 gallon cap.
BATTERY ----- 15 plate; 100 amp hr capacity	GENERATOR ----- 45 amp maximum rate
BODY --- Nominal 12-foot wood platform with steel skid strips. Steel cross sills, and full length wood side sills. Entire platform is bound by a steel channel-type rub rail with stake pockets integrally formed. Model 4409 is equipped with a 42 high stake rack.	LIGHTS ----- 2 head, 2 parking, and 1 tail and stop
BRAKES	MIRROR, REAR VIEW --- LH; long adjustable bracket
PARKING ----- Hand-operated on prop shaft; 35 sq. in. area	RUNNING BOARDS ----- Short
SERVICE ----- Hydraulic type; 4-wheel; 375 sq. in.	SEAT ----- Full width
FRONT ----- 14 x 2-1/2; 134 sq. in. area	SPARE WHEEL CARRIER ----- Underslung at rear
REAR ----- 15 x 4; 241 sq. in. area	SPRINGS ----- Semi-elliptic
BUMPER, FRONT ----- Rigid, channel-type; painted	FRONT --- 7-leaf, 40 x 2; 1740 lb (ea) cap. at ground
CAB ----- All-steel; welded; flexibly mounted	REAR ----- 11-leaf, 46 x 2-1/2; 4465 lb (ea) capacity at ground
CLUTCH -- Diaphragm spring; single disc type; 11 dia; 123.7 sq. in. area; 282 lb capacity	STEERING GEAR ----- Recirculating-ball type; 26.24 ratio; 18-inch dia wheel
COLOR, BASIC VEHICLE ----- Juniper Green	SUNSHADE ----- Adjustable for driver
COOLING SYSTEM ----- Cellular radiator core, 4 lb press. cap. 407 sq. in. frontal area; 17 quart capacity	TIRES ----- Front and dual rear; 6.50-20-6pr; 1700 lb (ea) capacity
DISPATCH BOX ----- 13-1/2 x 5-1/2 x 8-1/2	TOOLS ----- 8250 lb capacity jack; tire changing iron; wheel wrench
DOME LIGHT ----- Above rear window	TOOL BOX ----- Under seat; 50 x 19 x 6
DRIVE SYSTEM ----- Hotchkiss	TRANSMISSION --- 4-speed synchro-mesh; shift lever on transmission; provision for power take-off on left side
ENGINE ----- Thriftmaster; 235.5 cu. in. displ	VENTILATORS ----- Top of cowl and ventipanes
GROSS HP ----- 112 @ 3700 RPM	WHEELS ----- 7; wide-base rim; 20 x 5.0
GROSS TORQUE ----- 200 ft lb @ 2000 RPM	WINDSHIELD WIPERS ----- Dual; cowl mounted

**OPTIONAL EQUIPMENT**

For model application see Option Section

	Wt	Number
AIR CLEANER: AC make, oil bath type		
(2 pt cap. standard equip. on heavy duty engine RPO)		
1 pint capacity ----- *	216	
2 pint capacity ----- *	216	
AXLE, FRONT: Heavy Duty ----- 37F	203	
AXLE, REAR: Single-speed, full-floating; 5.43 ratio, 11000 lb capacity ----- *	204	
AXLE, 2-SPEED REAR: Full-floating, 13000 lb capacity; hypoid primary gears		
6.13 & 8.10 ratios ----- 170R	243	
BRAKE BOOSTER (Hydraulic) Long stroke, 7 dia; vacuum-operated ----- 11F, 9R	212	
COLORS, VEHICLE: Solid ----- *	234	
CORNER WINDOWS, CAB: Clear or tinted-*	387	
CRANKCASE VENTILATION: Vac-operated with filtered air from oil bath air cleaner --- *	217	
ENGINE, HEAVY DUTY: Loadmaster, 235.5 cu. in. displ Gross HP, 112 @ 3700 RPM Gross torque, 200 ft lb @ 2000 RPM ----- *	225	
EQUIPMENT, HEAVY DUTY: To increase max GVW from 11000 to 14000 lb, use the following group of options: 253, Front Springs; 267, Rear Springs; 212, Brake Booster; and at least 7.00-20-8pr Front and 7.50-20-8pr Dual Rear Tires --- 69F, 229F		
GENERATOR: Including voltage and current regulator, and pulley for high output		
40 amp ----- *	326	
50 amp ----- *	326	
55 amp ----- 27F	326	
55 amp, low cut-in ----- 24F	326	
GLASS EQUIPMENT, BODY: Tinted ----- *	399	
GOVERNOR: Range 2300-3200 RPM ----- *	241	
MIRROR, REAR VIEW: Long, RH ----- *	210	
OIL FILTER: AC make		
1 quart capacity ----- 8F	237	
2 quart capacity ----- 15F	237	
RADIATOR, HEAVY DUTY: 18 qt cap --- *	256	
SEAT EQUIPMENT: Unison ----- *	264	
SHOCK ABSORBERS: Direct double acting		
Front, 1-3/8 diameter piston ----- 16F	200	
Rear, 1-3/8 diameter piston ----- 24R	200	
SIDE DOOR KEY LOCK, LH ----- *	395	
SPRINGS, HEAVY DUTY:		
Front 8-leaf, 1900 lb (ea) capacity ----- *	253	
Rear 11-leaf, two-stage, 5600 lb (ea) capacity at ground ----- *	268	
REAR and AUXILIARY: Main 11-leaf; auxiliary 6-leaf, capacity at ground (main and auxiliary) 7800 lb (ea) ----- 76R	267	
TANK, VACUUM RESERVE: 1000cu. in. -6F, 6R	281	
TIRES, MAXIMUM: Front and Dual Rear, 7.50-20-10pr; 2700 lb (ea) cap -- 88F, 186R	305	
VACUUM BOOSTER and FUEL PUMP --- *	340	
WINDSHIELD WIPERS: Dual, Electric -- *	320	

\* - Weight is less than 10 pounds

10-29-54

**CHEVROLET 1955 SPECIFICATIONS—TRUCK**

**MODELS 4408, 4409 DATA - 101**

CHASSIS AND BODY DIMENSIONS

Model 4502 School Bus Flat Face Cowl Chassis

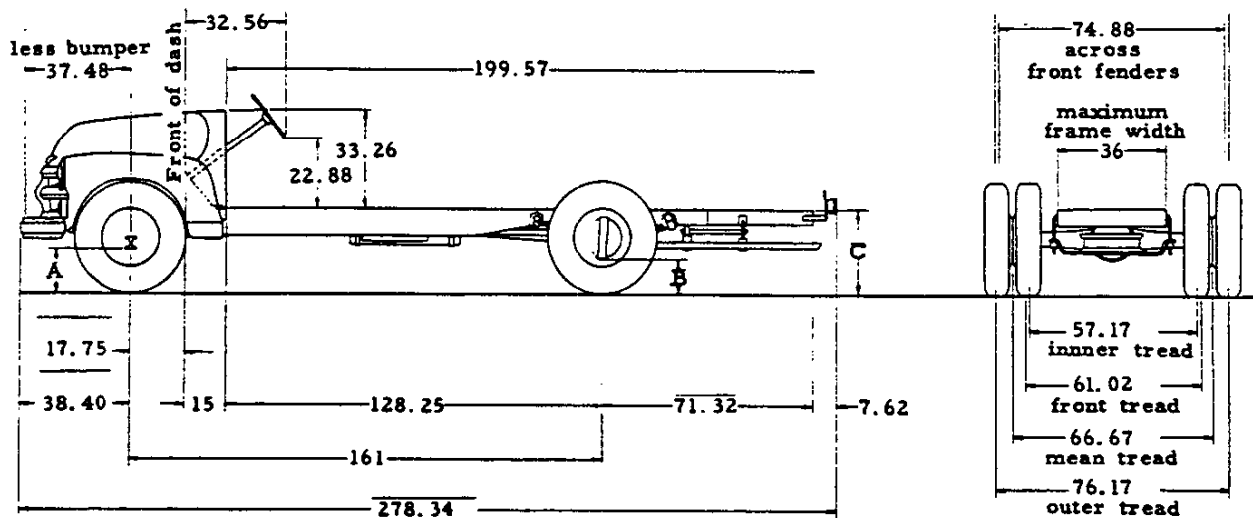

Equipment	Height Without Body and Payload		
	A	B	C
Standard	10.75	8.88	36.00
Minimum for Max GVW	10.75	9.36	36.69

To determine loaded and unloaded heights, body specifications must be known. Minimum tire equipment for Max GVW is 6.50-20-6pr front and 7.00-20-8pr dual rr.

VEHICLE WEIGHTS AND LOAD DISTRIBUTION

MODEL	WITH STANDARD EQUIPMENT						WITH MINIMUM EQUIPMENT FOR MAXIMUM GVW			
	Shipping			Curb			Body and Payload	Payload Distribution		Body Length
	Front	Rear	Total	Front	Rear	Total		Front	Rear	
4502	2150	1775	3925	2250	1940	4190	7800	Determined by Style, Length and weight of body.		

10-29-54  
102-MODEL 4502 DATA

CHEVROLET 1955 SPECIFICATIONS—TRUCK

## MODEL 4502 MEDIUM DUTY SCHOOL BUS FLAT FACE COWL CHASSIS

1-1/2 TON NOMINAL RATING --- 161 WHEELBASE --- 12000 lb MAXIMUM GVW

STANDARD EQUIPMENT	
AIR CLEANER ----- AC make; oil-wetted type	FRAME ----- Ladder type with 8 cross members
AXLE, FRONT ----- I-beam type;	channel side rails 8-7/8 x 2-7/8 x 1/4;
4500 lb cap	section modulus 8.80 in <sup>3</sup>
AXLE, REAR-- Full-floating type; 11000 lb capacity;	FUEL LINE, FLEXIBLE ----- Engine end
Hypoid gears; 6.17 ratio	FUEL TANK ----- Outside of frame on right side;
BATTERY ----- 19 plate; 125 amp hr capacity	30 gallon capacity
BRAKES -----	GENERATOR ----- 45 amp maximum rate
PARKING ----- Hand-operated on prop shaft	GOVERNOR ----- Set at 35 MPH
35 sq. in. area	LIGHTS----- 2 head, 2 parking, and 1 tail and stop
SERVICE ----- Hydraulic type; 4-wheel;	PROPELLER SHAFT GUARDS ----- Two
375 sq. in. area	SPARE WHEEL CARRIER ----- Underslung at rear
FRONT ----- 14 x 2-1/2; 134 sq. in. area	SPRINGS ----- Semi-elliptic
REAR ----- 15 x 4; 241 sq. in. area	FRONT -- 9-leaf, 40 x 2; 2200 lb (ea)cap. at ground
BUMPER, FRONT ----- Rigid, channel-type; painted	REAR ----- Two-stage; 11-leaf, 46 x 2-1/2;
CLUTCH--Diaphragm spring; single disc type; 11 dia;	5600 lb (ea) capacity at ground
123.7 sq. in. area; 282 ft lb capacity	STEERING GEAR ---- Recirculating-ball type; 27.76
COLOR, BASIC VEHICLE ----- Juniper Green	ratio; 18-inch dia wheel
COOLING SYSTEM ----- Cellular radiator core, 4 lb	TIRES ----- Front and dual rear; 6.50-20-6pr;
press. cap; 407 sq.in. frontal	1700 lb (ea) capacity
area; 17 quart capacity	TOOLS ---- 7000 lb capacity jack; tire changing iron;
DISPATCH BOX ----- 13-7/8 x 4-3/4 x 8-1/4	wheel wrench
DRIVE SYSTEM ----- Hotchkiss	TRANSMISSION -- 4-speed, synchro-mesh; shift lever
ENGINE ----- Thriftmaster; 235.5 cu. in. displ	on transmission; provision for
GROSS HP ----- 112 @ 3700 RPM	power take-off on left side
GROSS TORQUE ----- 200 ft lb @ 2000 RPM	VENTILATOR ----- Top of cowl
FENDERS ----- Front only	WHEELS ----- 7; wide-base rim; 20 x 5.0

### OPTIONAL EQUIPMENT

For model application see Option Section

	Wt	Number	Wt	Number
AIR CLEANER: AC make, oil bath type			40 amp ----- *	326
(2 pt cap. standard equip. on heavy duty engine RPO)			50 amp ----- *	326
2 pint capacity ----- *	216		55 amp ----- 27F	326
AXLE, REAR:			55 amp, low cut-in ----- 24F	326
Single speed, full-floating; 5.43			OIL FILTER: AC make	
ratio, 11000 lb capacity ----- *	204		1 quart capacity ----- 8F	237
AXLE, 2-SPEED REAR: Full-floating, 13000 lb			2 quart capacity ----- 15F	237
capacity; hypoid primary gears			RADIATOR, HEAVY DUTY:	
6.13 & 8.10 ratios ----- 170R	243		18 quart capacity ----- *	256
BRAKE BOOSTER (Hydraulic) Long stroke,			SHOCK ABSORBERS: Direct double-acting	
7 dia; vacuum-operated ----- 11F, 9R	212		Front 1-3/8 diameter piston ----- 16F	200
COLORS, VEHICLE: Solid ----- *	234		Rear 1-3/8 diameter piston ----- 24R	200
CRANKCASE VENTILATION: Vac-operated with			SPRINGS, FRONT:9-leaf with double-wrap	
filtered air from oil bath air cleaner --- *	217		eye at fixed end ----- *	255
ENGINE, HEAVY DUTY:			TANK, VACUUM RESERVE:	
Loadmaster, 235.5 cu.in. displ			1000 cu.in. capacity----- 6F,6R	281
Gross HP, 112 @ 3700 RPM			TIRES, MAXIMUM:	
Gross torque, 200 @ 2000 RPM ----- *	225		Front and Dual Rear: 7.50-20-10pr;	
GENERATOR: Including voltage and current			2700 lb (ea) capacity ----- 86F, 186R	305
regulator, and pulley for high output			VACUUM BOOSTER and FUEL PUMP --- *	340

\*-Weight is less than 10 pounds

10-29-54

CHEVROLET 1955 SPECIFICATIONS—TRUCK

MODEL 4502 DATA-103

**CHASSIS AND BODY DIMENSIONS**

Models 5103 (5103S) Cab Chassis

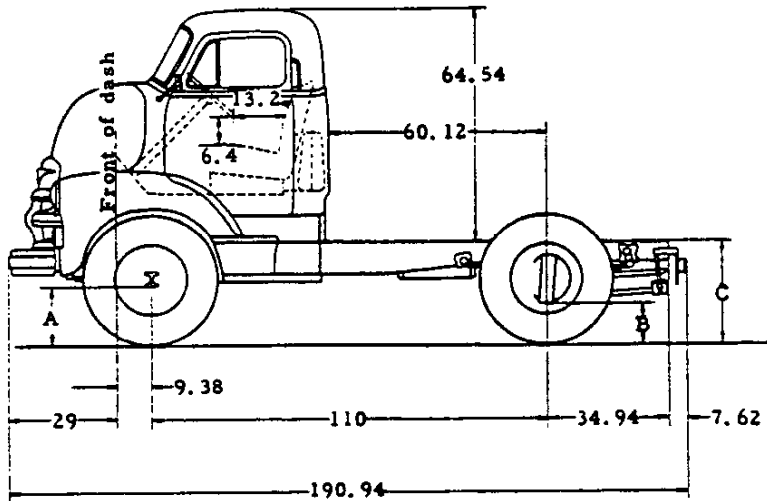

Seat in rear position  
adjustment 3.38

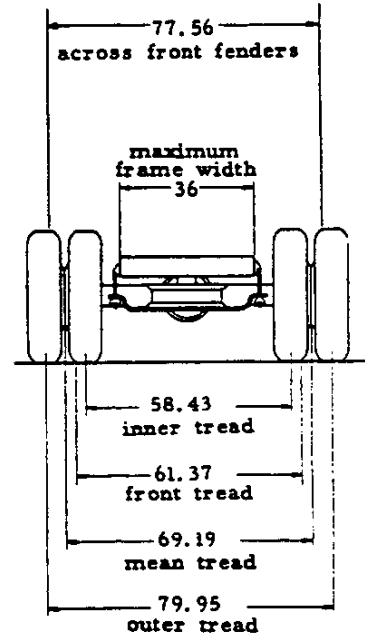

Equipment	Height Without Body and Payload		
	A	B	C
Standard	12.06	10.24	33.97
Minimum for Max GVW	12.06	10.78	34.68

To determine loaded and unloaded heights, body specifications must be known. Minimum tire equipment for max GVW is 7.50-20-8pr front and 8.25-20-10 dual rr.

**VEHICLE WEIGHTS AND LOAD DISTRIBUTION**

MODEL	WITH STANDARD EQUIPMENT						WITH MINIMUM EQUIPMENT FOR MAXIMUM GVW			
	Shipping			Curb			Body and Payload	Payload Distribution		Body Length
	Front	Rear	Total	Front	Rear	Total		Front	Rear	
5103 (S)	2635	1950	4585	2740	2055	4795	11150	12%	88%	90
								9%	91%	96
								6%	94%	102
								4%	96%	108

10-29-54.

104-MODEL 5103 (5103S) DATA

**CHEVROLET 1955 SPECIFICATIONS—TRUCK**

## MODEL 5103 (5103S) HEAVY DUTY C.O.E. CAB CHASSIS

2 TON (1-1/2 Ton Special) NOMINAL RATING---110 WHEELBASE---16000 lb (Special, 15000 lb) MAXIMUM GVW

### STANDARD EQUIPMENT

<p>AIR CLEANER --- AC make; oil bath type; 1 pt capacity</p> <p>AXLE, FRONT----- I-beam type; 4500 lb capacity</p> <p>AXLE, REAR----- Full-floating; 13000 lb capacity; Hypoid gears; 6.17 ratio</p> <p>BATTERY----- 15 plate; 100 amp hr capacity</p> <p><b>BRAKES</b></p> <p>PARKING----Hand-operated on prop shaft; 35 sq. in.</p> <p>SERVICE-----Hydraulic type; 4-wheel; 375 sq. in.</p> <p>FRONT-----14 x 2-1/2; 134 sq. in. area</p> <p>REAR-----15 x 4; 241 sq. in. area</p> <p>BOOSTER (hydraulic)----- Long stroke; 7 dia; vacuum-operated</p> <p>BUMPER, FRONT-----Rigid, channel-type; painted</p> <p>CAB----- All-steel; welded; flexibly mounted</p> <p>CLUTCH---Diaphragm spring; single disc type; 11 dia; 123.7 sq. in. area; 282 ft lb capacity</p> <p>COLOR, BASIC VEHICLE-----Juniper Green</p> <p>COOLING SYSTEM ---- Cellular radiator core; 4 lb press. cap; 407 sq. in. frontal area; 18 quart capacity</p> <p>DISPATCH BOX----- 13-1/2 x 5-1/2 x 8-1/2</p> <p>DOME LIGHT----- Above rear window</p> <p>DRIVE SYSTEM----- Hotchkiss</p> <p>PROPELLER SHAFT----- One</p> <p>PROPELLER SHAFT BRG SUPPORTS----- None</p> <p>UNIVERSAL JOINTS----- Two</p> <p>ENGINE -----Loadmaster; 235.5 cu in displ</p> <p>GROSS HP----- 110 @ 3600 RPM</p> <p>GROSS TORQUE----- 192 ft lb @ 2000 RPM</p> <p>FENDERS----- Front, COE type</p>	<p>FRAME ----- Ladder type with 5 cross members, channel side rails 8-7/8 x 2-7/8 x 1/4; section modulus 8.80 in<sup>3</sup></p> <p>FUEL TANK----- Back of seat in cab; 17-1/2 gal cap.</p> <p>GENERATOR----- 45 amp maximum rate</p> <p>GRAB HANDLES----- Left and right side</p> <p>LIGHTS ----- 2 head, 2 parking, and 1 tail and stop</p> <p>MIRROR, REAR VIEW----LH; long adjustable bracket</p> <p>RUNNING BOARDS-----Short; with step</p> <p>SEAT----- Full width</p> <p>SPARE WHEEL CARRIER----- Underslung at rear</p> <p><b>SPRINGS</b></p> <p>FRONT----- Semi-elliptic; 9-leaf, 40 x 2; 2200 lb(ea) capacity at ground</p> <p>REAR----- Semi-elliptic; 7800 lb (ea) capacity</p> <p>MAIN----- 11-leaf, 46 x 2-1/2</p> <p>AUXILIARY----- 6-leaf, 31 x 2-1/2</p> <p>STEERING GEAR -----Recirculating-ball type; 27.76 ratio; 18-inch dia wheel</p> <p>SUNSHADE ----- Adjustable; for driver</p> <p>TIRES ----- Front and dual rear; 7.50-20-8pr; 2375 lb (ea) capacity</p> <p>TOOLS ----- 8250 lb cap. jack; tire iron; wheel wrench</p> <p>TOOL BOX----- Under seat; 50 x 19 x 6</p> <p>TRANSMISSION -- 4-speed, synchro-mesh; shift lever mounted on floor; provision for power take-off on left side</p> <p>VENTILATORS----- Top of cowl and ventipanes</p> <p>WHEELS----- 7; wide-base rim; 20 x 6.0</p> <p>WINDSHIELD WIPERS----- Dual; cowl mounted</p>
---	--

### OPTIONAL EQUIPMENT

For model application see Option Section

	Wt	Number		Wt	Number
AXLE, 2-SPEED REAR: Full-floating 13000 lb capacity; Hypoid primary gears			PLATE, IDENTIFICATION		
6.13 and 8.10 ratios -----	104R	202	1-1/2 Ton Special -----	*	402
6.70 and 8.86 ratios -----	104R	201	SEAT EQUIPMENT: Unions -----	*	264
COLORS, VEHICLE: Solid -----	*	234	<b>SHOCK ABSORBERS:</b>		
CORNER WINDOWS, CAB -----	*	387	Direct double-acting.		
CRANKCASE VENTILATION: Vac-operated with filtered air from oil bath air cleaner --- *	*	217	Front, 1-3/8 diameter piston -----	16F	200
<b>ENGINE, HEAVY DUTY:</b>			Rear, 1-3/8 diameter piston -----	24R	200
Jobmaster, 261 cu. in. displ			<b>SIDE DOOR KEY LOCK, LH -----</b>	*	395
Gross HP, 125 @ 3800 RPM			<b>SPRINGS, REAR: Two-stage, 11-leaf;</b>		
Gross torque, 215 @ 1200-2000 RPM-----	*	225	5600 lbs (ea) capacity at ground Minus--	75R	268
<b>GENERATOR: Including voltage and current regulator, and pulley for high output</b>			<b>TANK, VACUUM RESERVE:</b>		
40 amp -----	*	326	1000 cu. in. capacity -----	6F, 6R	281
50 amp -----	*	326	<b>TIRES, MAXIMUM: RPO 291 mandatory</b>		
<b>GLASS EQUIPMENT, BODY: Tinted -----</b>	*	399	Front, 8.25-10pr; 2900 lb (ea)		
<b>GOVERNOR: Range 2300-3200 RPM,</b>			capacity -----	40F	343
Heavy Duty Engine, 2400-3400 RPM, --- *	*	241	Dual Rear, 9.00-20-10pr; 3450 lb (ea)		
<b>MIRROR, REAR VIEW:</b>			capacity -----	150R	312
Short, RH and LH; Long, RH -----	*	210	<b>VACUUM BOOSTER and FUEL PUMP -----</b>	*	340
<b>OIL FILTER: AC make,</b>			<b>WHEELS: (20 x 6.5) For 8.25 or 9.00 x 20 tires;</b>		
2 quart capacity -----	15F	237	5 Wheels (For fleet users only) -----	25R	291
			7 Wheels -----	10F, 25R	291
			<b>WINDSHIELD WIPERS:</b>		
			Dual, Electric -----	*	320

\* - Weight is less than 10 pounds

10-29-54

**CHEVROLET 1955 SPECIFICATIONS—TRUCK**

**MODEL 5103 (5103S) DATA-105**

CHASSIS AND BODY DIMENSIONS

Model 5403 (5403S) C. O. E. CAB CHASSIS

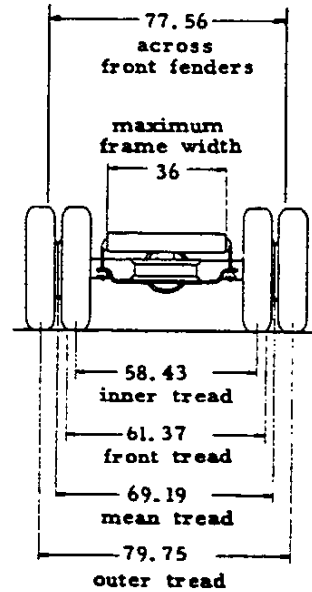
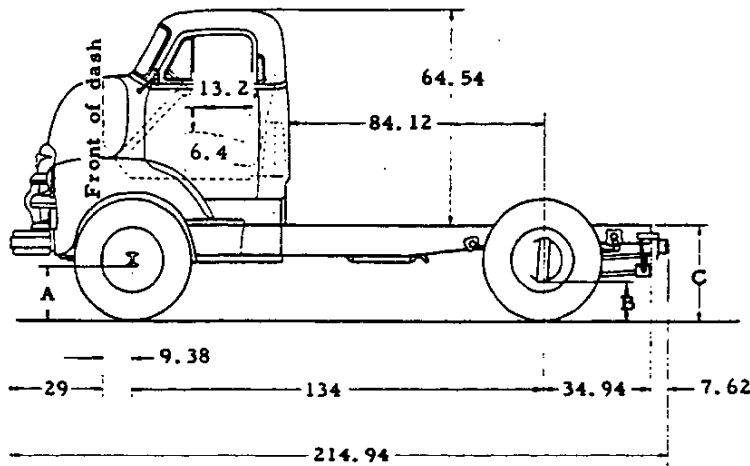

Seat in rear position  
adjustment 3.38

Equipment	Height Without Body and Payload		
	A	B	C
Standard	12.06	10.24	33.22
Minimum for Max GVW	12.06	10.78	33.86

To determine loaded and unloaded heights, body specifications must be known. Minimum tire equipment for max GVW is 7.50-20-8pr front and 8.25-20-10 dual rr.

VEHICLE WEIGHTS AND LOAD DISTRIBUTION

MODEL	WITH STANDARD EQUIPMENT						WITH MINIMUM EQUIPMENT FOR MAXIMUM GVW			
	Shipping			Curb			Body and Payload	Payload Distribution		Body Length
	Front	Rear	Total	Front	Rear	Total		Front	Rear	
5403 (S)	2695	1955	4650	2810	2050	4860	11100	17%	83%	120
								12%	88%	132
								10%	90%	138
								8%	92%	144

10-29-54

106 - MODEL 5403 (5403S) DATA

CHEVROLET 1955 SPECIFICATIONS—TRUCK

## MODEL 5403 (5403S) HEAVY DUTY C.O.E. CAB CHASSIS

2 TON (1-1/2 Ton Special) NOMINAL RATING --- 134 WHEELBASE --- 16000 (Special, 15000 lb) MAXIMUM GVW

### STANDARD EQUIPMENT

<p>AIR CLEANER -----AC make, oil bath type, 1 pint capacity</p> <p>AXLE, FRONT-----I-beam type; 4500 lb cap.</p> <p>AXLE, REAR---- Full-floating type; 13000 lb capacity; hypoid gears; 6.17 ratio</p> <p>BATTERY----- 15 plate; 100 amp hr capacity</p> <p>BRAKES PARKING---- Hand-operated on prop shaft, 35 sq. in. SERVICE-----Hydraulic type; 4-wheel; 375 sq. in. FRONT-----14 x 2-1/2; 134 sq. in. area REAR----- 15 x 4; 241 sq. in. area</p> <p>BOOSTER (Hydraulic)----- Long stroke, 7 dia; vacuum-operated</p> <p>BUMPER, FRONT----- Rigid, channel type; painted</p> <p>CAB ----- All-steel; welded; flexibly mounted</p> <p>CLUTCH---Diaphragm spring, single disc type; 11 dia; 123.7 sq. in. area; 282 ft lb capacity</p> <p>COLOR, BASIC VEHICLE-----Juniper Green</p> <p>COOLING SYSTEM-----Cellular radiator core, 4 lb press. cap; 407 sq. in. frontal area; 18 quart capacity</p> <p>DISPATCH BOX----- 13-1/2 x 5-1/2 x 8-1/2</p> <p>DOME LIGHT----- Above rear window</p> <p>DRIVE SYSTEM----- Hotchkiss</p> <p>PROPELLER SHAFTS-----Two</p> <p>PROPELLER SHAFT BRG SUPPORTS-----One</p> <p>UNIVERSAL JOINTS----- Three</p> <p>ENGINE----- Loadmaster, 235.5 cu. in. GROSS HP----- 110 @ 3600 RPM GROSS TORQUE----- 192 ft lb @ 2000 RPM</p> <p>FENDERS, COE TYPE----- Front only</p>	<p>FRAME-----Ladder type with 5 cross members, channel side rails 8-7/8 x 2-7/8 x 1/4; section modulus 8.80 in<sup>3</sup></p> <p>FUEL TANK----- Back of seat in cab; 17-1/2 gal capacity</p> <p>GENERATOR----- 45 amp maximum rate</p> <p>GRAB HANDLES----- Left and right side</p> <p>LIGHTS ----- 2 Head, 2 Parking, and 1 Tail and Stop</p> <p>MIRROR, REAR VIEW ---- LH, long adjustable bracket</p> <p>RUNNING BOARDS ----- Short with step</p> <p>SEAT ----- Full width</p> <p>SPARE WHEEL CARRIER ----- Underslung at rear</p> <p>SPRINGS FRONT ----- Semi-elliptic; 11-leaf, 40 x 2; 2400 lb (ea) capacity at ground REAR----- Semi-elliptic 7800 lb (ea) cap. at ground MAIN ----- 11-leaf, 46 x 2-1/2 AUXILIARY ----- 6-leaf, 31 x 2-1/2</p> <p>STEERING GEAR----- Recirculating-ball type, 27.76 ratio; 18 dia wheel</p> <p>SUNSHADE ----- Adjustable, for driver</p> <p>TIRES----- Front and Dual Rear, 7.50-20-8pr; 2375 lb (ea) capacity</p> <p>TOOLS ----- 8250 lb capacity jack; tire changing iron; wheel wrench</p> <p>TOOL BOX ----- Under seat, 50 x 19 x 6</p> <p>TRANSMISSION --- 4-Speed synchro-mesh, shift lever on floor; provision for power take- off on left side</p> <p>VENTILATORS-----Top of cowl and ventipanes</p> <p>WHEELS----- 7, wide base rim; 20 x 6.0</p> <p>WINDSHIELD WIPERS----- Dual, cowl mounted</p>
--	--

### OPTIONAL EQUIPMENT

For model application see Option Section

	Wt	Number		Wt	Number
AXLE, 2-SPEED REAR: Full-floating; 13000 lb capacity; Hypoid primary gears.			PLATE, IDENTIFICATION:		
6.13 and 8.10 ratios ----- 104R	202		1-1/2 Ton Special----- *	*	402
6.70 and 8.86 ratios ----- 104R	201		SEAT EQUIPMENT:		
COLORS VEHICLE: Solid ----- *	234		Unison ----- *	*	264
CORNER WINDOWS, CAB----- *	387		SHOCK ABSORBERS: Direct double-acting		
CRANKCASE VENTILATION: Vac-operated with filtered air from oil bath air cleaner----- *	217		Front, 1-3/8 diameter piston----- 16F	200	
ENGINE, HEAVY DUTY:			Rear, 1-3/8 diameter piston----- 24R	200	
Jobmaster, 261 cu. in. displ			SIDE DOOR KEY LOCK, LH----- *	395	
Gross HP, 125 @ 3800 RPM			SPRINGS, REAR: Two-stage, 11-leaf; 5600 lb (ea) cap. at ground----- Minus75R	268	
Gross torque, 215 ft lb 1200-2000 RPM--- *	225		TANK, VACUUM RESERVE:		
GENERATOR: Including voltage and current regulator, and pulley for high output			1000 cu. in. capacity----- 6F, 6R	281	
40 amp----- *	326		TIRES, MAXIMUM: RPO 291 mandatory		
50 amp----- *	326		Front, 8.25-20-10pr; 2900 lb (ea)		
GLASS EQUIPMENT, BODY: Tinted----- *	399		capacity----- 40F	343	
GOVERNOR: Range 2300-3200 RPM:			Dual Rear, 9.00-20-10pr; 3450 lb (ea)		
Heavy Duty Engine, 2400-3400 RPM---- *	241		capacity----- 150R	312	
MIRROR, REAR VIEW:			VACUUM BOOSTER AND FUEL PUMP--- *	340	
Short, RH or LH----- *	210		WHEELS (20 x 6.5)		
Long, RH----- *	210		For 8.25 or 9.00 x 20 tires		
OIL FILTER: AC make,			5 Wheels (For fleet users only)----- 25R	291	
2 quart capacity----- 15F	237		7 Wheels----- 10F, 25R	291	
			WINDSHIELD WIPERS:		
			Dual, Electric----- *	320	

\* - Weight is less than 10 pounds

10-29-54

CHEVROLET 1955 SPECIFICATIONS—TRUCK

MODEL 5403 (5403S) DATA-107



CHASSIS AND BODY DIMENSIONS

Model 5408 (5408S) C. O. E. Platform Truck

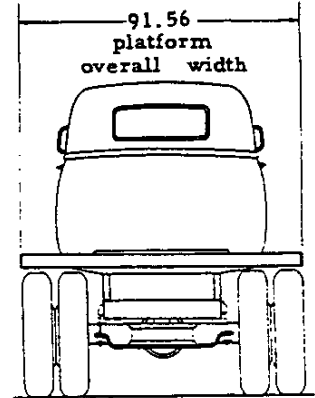
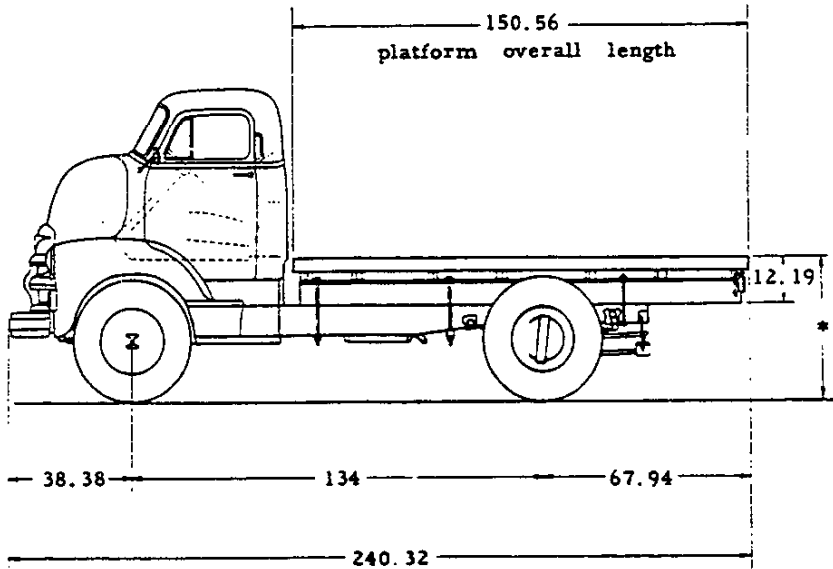

Equipment	*Platform Height		Tires	
	Loaded	Unloaded	Front	Rear
Standard	41.94	45.39	7.50-20-8pr	7.50-20-8pr dual
Minimum for Max GVW	42.64	46.22	7.50-20-8pr	8.25-20-10pr dual

Model 5409 (5409S) C. O. E. Stake Truck

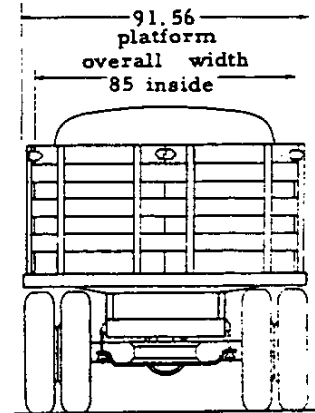
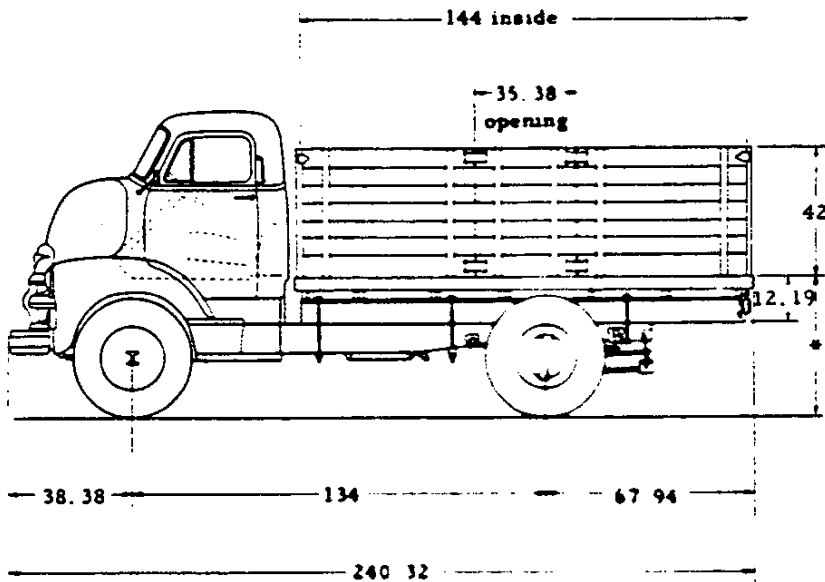

Equipment	*Platform Height		Tires	
	Loaded	Unloaded	Front	Rear
Standard	41.94	45.20	7.50-20-8pr	7.50-20-8pr dual
Minimum for Max GVW	42.64	46.02	7.50-20-8pr	8.25-20-10pr dual

VEHICLE WEIGHTS AND LOAD DISTRIBUTION

MODEL	WITH STANDARD EQUIPMENT						WITH MINIMUM EQUIPMENT FOR MAXIMUM GVW			
	Shipping			Curb			Payload	Payload Distribution		Body Length
	Front	Rear	Total	Front	Rear	Total		Front	Rear	
5408 (S)	2770	2620	5390	2880	2715	5595	10350	4%	96%	150.56
5409 (S)	2795	2870	5665	2910	2965	5875	10050	6%	94%	144.00

10-29-54

108-MODEL 5408 (S), 5409 (S) DATA

CHEVROLET 1955 SPECIFICATIONS—TRUCK

**MODEL 5408 (5408S) HEAVY DUTY C.O.E. PLATFORM TRUCK  
MODEL 5409 (5409S) HEAVY DUTY C.O.E. STAKE TRUCK**

2 TON (1-1/2 Ton Special) NOMINAL RATING --- 134 WHEELBASE --- 16000 lb (Special, 15000 lb) MAXIMUM GVW  
STANDARD EQUIPMENT

<p>AIR CLEANER -- AC make, oil bath type, 1 pt capacity AXLE, FRONT ----- I-beam type; 4500 lb capacity AXLE, REAR --- Full-floating type, 13000 lb capacity; hypoid gears, 6.17 ratio BATTERY ----- 15 plate; 100 amp hr capacity BODY----- Nominal 12-foot wood platform with steel skid strips. Steel cross sills and full length wood side sills. Entire platform is bound by a steel channel-type rub rail with stake pockets integrally formed. Model 5409 is equipped with a 42 high stake rack.</p> <p>BRAKES PARKING ----- Hand-operated on prop shaft; 35 sq. in. SERVICE ----- Hydraulic type, 4-wheel; 375 sq. in. FRONT ----- 14 x 2-1/2; 134 sq. in. area REAR ----- 15 x 4; 241 sq. in. area BOOSTER (Hydraulic) ----- Long stroke, 7 dia; vacuum-operated BUMPER, FRONT ----- Rigid, channel-type; painted CAB ----- All-steel; welded; flexibly mounted CLUTCH ----- Diaphragm spring, single disc type; 11 dia, 123.7 sq. in. area; 282 ft lb capacity COLOR, BASIC VEHICLE ----- Juniper Green COOLING SYSTEM ---- Cellular radiator core, 4 lb press. cap; 407 sq. in. frontal area; 18 quart capacity DISPATCH BOX ----- 13-1/2 x 5-1/2 x 8-1/2 DOME LIGHT ----- Above rear window DRIVE SYSTEM ----- Hotchkiss PROPELLER SHAFTS ----- Two PROPELLER SHAFT BRG SUPPORTS ----- One UNIVER. :L JOINTS ----- Three</p>	<p>ENGINE ----- Loadmaster, 235.5 cu. in. displ GROSS HP ----- 110 @ 3600 RPM GROSS TORQUE ----- 192 @ 2000 RPM FENDERS ----- Front only FRAME ----- Ladder type with 5 cross members, channel side rails 8-7/8 x 2-7/8 x 1/4; section modulus 8.80 in.<sup>3</sup> FUEL TANK ----- Back of seat in cab; 17-1/2 gal capacity GENERATOR ----- 45 amp maximum rate GRAB HANDLES ----- Left and Right side LIGHTS ----- 2 Head, 2 parking, and 1 tail and stop MIRROR, REAR VIEW --- LH; long adjustable bracket RUNNING BOARDS ----- Short with step SEAT ----- Full width SPARE WHEEL CARRIER ----- Underslung at rear SPRINGS FRONT ----- Semi-elliptic 11-leaf, 40 x 2; 2400 lb (ea) capacity at ground REAR ----- Semi-elliptic 7800 lb (ea) capacity MAIN ----- 11-leaf, 46 x 2-1/2 AUXILIARY ----- 6-leaf, 31 x 2-1/2 STEERING GEAR ----- Recirculating-ball type, 27.76 ratio; 18 dia wheel SUNSHADE ----- Adjustable, for driver TIRES ----- Front and Dual Rear, 7.50-20-8pr; 2375 lb (ea) capacity TOOLS ----- 8250 lb capacity jack; tire changing iron; wheel wrench TOOL BOX ----- Under seat, 50 x 19 x 6 TRANSMISSION -- 4-Speed, Synchro-mesh, shift lever on floor; provision for power take-off on left side VENTILATORS ----- Top of cowl and ventipanes WHEELS ----- 7, wide-base rim; 20 x 6.0 WINDSHIELD WIPERS ----- Dual; cowl mounted</p>
--	--

**OPTIONAL EQUIPMENT**

For model application see Option Section

	Wt	Number		Wt	Number
AXLE, 2-SPEED REAR: Full-floating; 13000 lb capacity; Hypoid primary gears			PLATE, IDENTIFICATION:		
6.13 and 8.10 ratios -----	104R	202	1-1/2 Ton Special ----- *		402
6.70 and 8.86 ratios -----	104R	201	SEAT EQUIPMENT:		
COLORS, VEHICLE: Solid ----- *		234	Unison ----- *		264
CORNER WINDOWS, CAB ----- *		387	SHOCK ABSORBERS: Direct double-acting		
CRANKCASE VENTILATION: Vac-operated with filtered air from oil bath air cleaner --- *		217	Front, 1-3/8 diameter piston -----	16F	200
ENGINE, HEAVY DUTY:			Rear, 1-3/8 diameter piston -----	24R	200
Jobmaster, 261 cu. in. displ			SIDE DOOR KEY LOCK:		
Gross HP, 125 @ 3800 RPM			Left hand ----- *		395
Gross Torque, 215 @ 1200-2000 RPM -- *		225	SPRINGS, REAR:		
GENERATOR: Including voltage and current regulator, and pulley for high output			Two-stage 11-leaf; 5600 lb (ea) capacity at ground -----	Minus 75R	268
40 amp ----- *		326	TANK, VACUUM RESERVE:		
50 amp ----- *		326	1000 cu. in. capacity -----	6F, 6R	281
GLASS EQUIPMENT, BODY: Tinted ----- *		399	TIRES, MAXIMUM: RPO 291 mandatory		
GOVERNOR: Range 2300-3200 RPM,			Front and Dual Rear, 8.25-20-12pr;		
Heavy Duty Engine, 2400-3400 RPM ---- *		241	3150 lb (ea) capacity -----	56F, 116R	344
MIRROR, REAR VIEW:			VACUUM BOOSTER AND FUEL PUMP --- *		340
Long RH ----- *		210	WHEELS: (20 x 6.5) For 8.25 or 9.00 x 20 tires		
OIL FILTER: AC make,			5 Wheels (For fleet users only) -----	25R	291
2 quart capacity -----	15F	237	7 Wheels -----	10F, 25R	291
			WINDSHIELD WIPERS:		
			Dual, Electric ----- *		320

\* -Weight is less than 10 pounds

10-29-54

**CHEVROLET 1955 SPECIFICATIONS—TRUCK**

**MODEL 5408 (5408S), 5409 (5409S) DATA-109**

CHASSIS AND BODY DIMENSIONS

Model 5703 (5703S) C.O.E. Cab Chassis

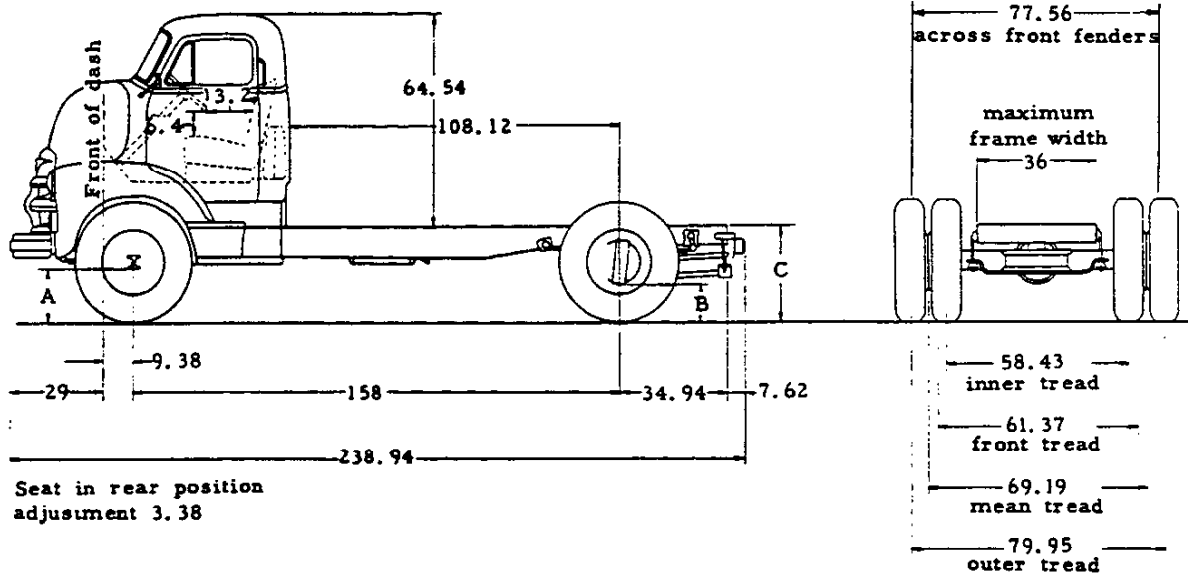

Equipment	Height Without Body and Payload		
	A	B	C
Standard	12.03	10.24	33.13
Minimum for Max GVW	12.03	10.78	33.79

To determine loaded and unloaded heights, body specifications must be known. Minimum tire equipment for max GVW is 7.50-20-8pr front and 8.25-20-10 dual rr.

VEHICLE WEIGHTS AND LOAD DISTRIBUTION

MODEL	WITH STANDARD EQUIPMENT						WITH MINIMUM EQUIPMENT FOR MAXIMUM GVW			
	Shipping			Curb			Body and Payload	Payload Distribution		Body Length
	Front	Rear	Total	Front	Rear	Total		Front	Rear	
5703 (S)	2765	1970	4735	2885	2060	4945	10950	14%	86%	168
								10%	90%	180
								6%	94%	192

10-29-54

110-MODEL 5703 (5703S) DATA

CHEVROLET 1955 SPECIFICATIONS—TRUCK

## MODEL 5703 (5703S) HEAVY DUTY C.O.E. CAB CHASSIS

2 TON (1-1/2 Ton Special) NOMINAL RATING --- 158 WHEELBASE --- 16000lb (Special, 15000 lb) MAXIMUM GVW

### STANDARD EQUIPMENT

<p>AIR CLEANER -- AC make, oil bath type, 1 pt capacity                  AXLE, FRONT ----- I-beam type; 4500 lb capacity                  AXLE, REAR ----- Full-floating; 13000 lb capacity hypoid gears; 6.17 ratio                  BATTERY ----- 15 plate; 100 amp hr capacity                  BRAKES                      PARKING --- Hand-operated; on prop shaft, 35 sq. in.                      SERVICE ----- Hydraulic type; 4-wheel; 375 sq. in.                          Front ----- 14 x 2-1/2; 134 sq. in. area                          Rear ----- 15 x 4; 241 sq. in. area                      Booster, (Hydraulic) ----- Long stroke; 7-dia; vacuum-operated                  BUMPER, FRONT ----- Rigid, channel-type; painted                  CAB ----- All steel; welded; flexibly mounted                  CLUTCH -- Diaphragm spring, single disc type; 11 dia; 123.7 sq. in. area; 282 ft lb capacity                  COLOR, BASIC VEHICLE ----- Juniper Green                  COOLING SYSTEM ---- Cellular radiator core, 4lb press. cap; 407 sq. in. frontal area; 18 quart capacity                  DISPATCH BOX ----- 13-1/2 x 5-1/2 x 8-1/2                  DOME LIGHT ----- Above rear window                  DRIVE SYSTEM ----- Hotchkiss                      PROPELLER SHAFTS ----- Two                      PROPELLER SHAFT BRG SUPPORTS ----- One                      UNIVERSAL JOINTS ----- Three                  ENGINE ----- Loadmaster; 235.5 cu. in. displ                      GROSS HP ----- 110 @ 3600 RPM                      GROSS TORQUE ----- 192 ft lb @ 2000 RPM                  FENDERS, COE TYPE ----- Front only</p>	<p>FRAME ----- Ladder type with 6 cross members, channel side rails 8-7/8 x 2-7/8 x 1/4; section modulus 8.80 in<sup>3</sup>                  FUEL TANK ----- Back of seat in cab; 17-1/2 gal. cap.                  GENERATOR ----- 45 amp maximum rate                  GRAB HANDLES ----- Left and right side                  LIGHTS ----- 2 head, 2 parking, and 1 tail and stop                  MIRROR, REAR VIEW ---- LH; long adjustable bracket                  RUNNING BOARDS ----- Short, with step                  SEAT ----- Full width                  SPARE WHEEL CARRIER ----- Underslung at rear                  SPRINGS                      FRONT ----- Semi-elliptic 11-leaf, 40 x 2; 2400 lb (ea) capacity at ground                      REAR ----- Semi-elliptic 7800 lb (ea) cap. at ground                          MAIN ----- 11-leaf, 46 x 2-1/2                          AUXILIARY ----- 6-leaf, 31 x 2-1/2                  STEERING GEAR ----- Recirculating-ball type; 27.76 ratio; 18 dia wheel                  SUNSHADE ----- Adjustable; for driver                  TIRES ----- Front and Dual Rear; 7.50-20-8pr; 2375 lb (ea) capacity                  TOOLS ----- 8250 lb cap. jack; tire iron; wheel wrench                  TOOL BOX ----- Under seat; 50 x 19 x 6                  TRANSMISSION -- 4-Speed, Synchro-mesh; shift lever mounted on floor; provision for power take-off on left side                  VENTILATORS ----- Top of cowl and ventipanes                  WHEELS ----- 7; wide-base rim; 20 x 6.0                  WINDSHIELD WIPERS ----- Dual; cowl mounted</p>
---	---

### OPTIONAL EQUIPMENT

For model application see Option Section

	Wt	Number		Wt	Number
AXLE, 2-SPEED REAR: Full-floating; 13000 lb capacity; Hypoid primary gears			PLATE IDENTIFICATION		
6.13 and 8.10 ratios -----	105R	202	1-1/2 Ton Special -----	*	402
6.70 and 8.86 ratios -----	105R	201	SEAT EQUIPMENT		
COLORS, VEHICLE: Solid -----	*	234	Unison -----	*	264
CORNER WINDOWS, CAB -----	*	387	SHOCK ABSORBERS: Direct double-acting		
CRANKCASE VENTILATION: Vac-operated with filtered air from oil bath air cleaner ---	*	217	Front, 1-3/8 diameter piston -----	16F	200
ENGINE, HEAVY DUTY			Rear, 1-3/8 diameter piston -----	24R	200
Jobmaster, 261 cu. in. displ			SIDE DOOR KEY LOCK		
GROSS HP, 125 @ 3800 RPM			Left Hand -----	*	395
GROSS TORQUE, 215 @ 1200-2000 RPM --	*	225	SPRINGS, REAR: Two-stage; 11-leaf; 5600 lbs (ea) capacity at ground--Minus 75R		268
GENERATOR: Including voltage and current regulator, and pulley for high output			TANK, VACUUM RESERVE:		
40 amp -----	*	326	1000 cu. in. capacity -----	6F, 6R	281
50 amp -----	*	326	TIRES, MAXIMUM: RPO 291 mandatory		
GLASS EQUIPMENT, BODY			Front, 8.25-20-10 pr; 2900 lb (ea)		
Tinted -----	*	399	capacity -----	40	343
GOVERNOR: Range 2300-3200 RPM;			Dual Rear, 9.00-20-10 pr; 3450 lb (ea)		
Heavy Duty Engine, 2400-3400 RPM ----	*	241	capacity -----	150	312
MIRROR, REAR VIEW			VACUUM BOOSTER AND FUEL PUMP ---	*	340
Short, RH or LH -----	*	210	WHEELS (20 x 6.5)		
Long, RH -----	*	210	For 8.25 or 9.00 x 20 tires		
OIL FILTER: AC make,			5 Wheels (For fleet users only) -----	25R	291
2 quart capacity -----	15F	237	7 Wheels -----	10F, 25R	291
			WINDSHIELD WIPERS:		
			Dual, Electric -----	*	320

\* - Weight is less than 10 pounds

10-29-54.

CHEVROLET 1955 SPECIFICATIONS--TRUCK

MODEL 5703 (5703S) DATA-111

**CHASSIS AND BODY DIMENSIONS**

Model 6102 (6102S) Flat Face Cowl Chassis  
 Model 6112 (6112S) Windshield Cowl Chassis

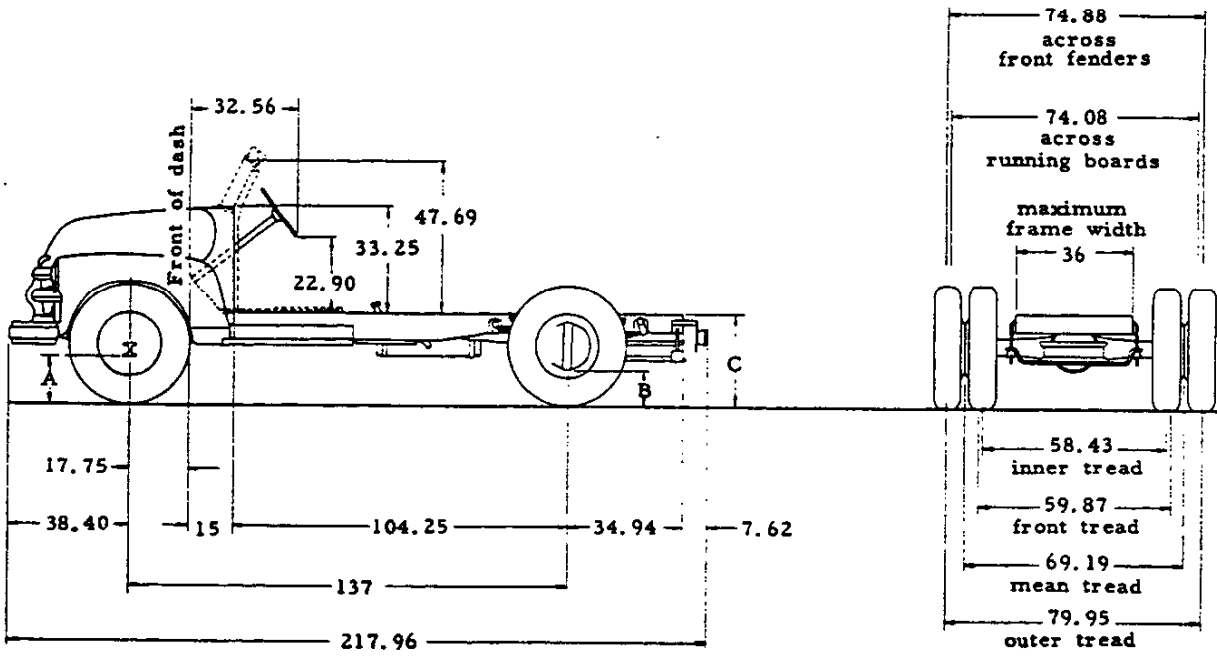

Equipment	Height Without Body and Payload		
	A	B	C
Standard	12.14	10.25	33.78
Minimum for Max GVW	12.14	10.80	34.56

To determine loaded and unloaded heights, body specifications must be known.  
 Minimum tire equipment for max GVW is 7.50-20-8pr front and 8.25-20-10 dual rr.

**VEHICLE WEIGHTS AND LOAD DISTRIBUTION**

MODEL	WITH STANDARD EQUIPMENT						WITH MINIMUM EQUIPMENT FOR MAXIMUM GVW			
	Shipping			Curb			Body and Payload	Payload Distribution		Body Length
	Front	Rear	Total	Front	Rear	Total		Front	Rear	
6102(S)	2170	1930	4100	2220	2090	4310	11650	Determined by style, length and weight of body.		
6112(S)⊙	2255	1905	4160	2305	2065	4370	11550			

10-29-54

⊙ - Estimated weight

**112 - MODELS 6102 (6102S), 6112 (6112S) DATA**

**CHEVROLET 1955 SPECIFICATIONS—TRUCK**

**MODEL 6102 (6102S) HEAVY DUTY FLAT FACE COWL CHASSIS  
MODEL 6112 (6112S) HEAVY DUTY WINDSHIELD COWL CHASSIS**

2 TON (1-1/2 Ton Special) NOMINAL RATING --- 137 WHEELBASE --- 16000 lb (Special, 15000 lb) MAXIMUM GVW

**STANDARD EQUIPMENT**

<p>AIR CLEANER --AC make, oil bath type, 1 qt capacity                  AXLE, FRONT ----- I-beam type;                  4500 lb cap.                  AXLE, REAR ----Full-floating type; 13000 lb capacity;                  hypoid gears; 6.17 ratio                  BATTERY -----15 plate; 100 amphr capacity;                  BRAKES                  PARKING ---Hand-operated on prop shaft; 35 sq. in.                  SERVICE ----- Hydraulic type; 4-wheel; 375 sq. in.                  FRONT -----14 x 2-1/2; 134 sq. in. area                  REAR -----15 x 4; 241 sq. in. area                  BOOSTER (Hydraulic) ----- Long stroke, 7 dia;                  vacuum-operated                  BUMPER, FRONT ----- Rigid; channel type, painted                  CLUTCH --Diaphragm spring, single disc type; 11 dia;                  123.7 sq. in. area; 282 ft lb capacity                  COLOR, BASIC VEHICLE ----- Juniper Green                  COOLING SYSTEM ---- Cellular radiator core, 4 lb                  press. cap; 407 sq. in. frontal                  area; 18 quart capacity                  DISPATCH BOX ----- 6102, 13-7/8 x 4-3/4 x 8-1/4;                  6112, 13-1/2 x 5-1/2 x 8- 1/2                  DRIVE SYSTEM ----- Hotchkiss                  PROPELLER SHAFTS ----- Two                  PROPELLER SHAFT BRG SUPPORTS ----- One                  UNIVERSAL JOINTS ----- Three                  ENGINE -----Loadmaster; 235.5 cu. in. displ                  GROSS HP -----112 @ 3700 RPM                  GROSS TORQUE ----- 200 ft lb @ 2000 RPM                  FENDERS -----Front only</p>	<p>FRAME ----- Ladder type with 5 cross members                  channel side rails 8-7/8 x 2-7/8 x 1/4;                  section modulus 8.80 in<sup>3</sup>                  FUEL TANK ----- Outside of frame on right side;                  18 gallon capacity                  GENERATOR -----45 amp maximum rate                  LIGHTS ----- 2 Head, 2 parking, and 1 tail and stop                  RUNNING BOARDS ----- Short                  SEAT RISER -----6112 only                  SPARE WHEEL CARRIER -----Underslung at rear                  SPRINGS                  FRONT -----Semi-elliptic; 9-leaf, 40 x 2;                  2200 lb (ea) capacity at ground                  REAR ----Semi-elliptic; 7800 lb (ea) cap. at ground                  MAIN -----11-leaf, 46 x 2-1/2                  AUXILIARY -----6-leaf, 31 x 2-1/2                  STEERING GEAR ----- Recirculating-ball type; 27.76                  ratio; 18 dia wheel                  TIRES -----Front and dual rear; 7.50-20-8pr;                  2375 lb (ea) capacity                  TOOLS ----- 8250 lb capacity jack; tire changing iron;                  wheel wrench                  TOOL BOX (6112 only) ----- 50 x 19 x 2-3/8                  TRANSMISSION--- 4-Speed, Synchro-mesh; shift lever                  on transmission; provision for                  power take-off on left side                  VENTILATOR ----- Top of cowl                  WHEELS -----7; wide-base rim; 20 x 6.0                  WINDSHIELD WIPERS                  6112 only ----- Dual; cowl mounted</p>
--	---

**OPTIONAL EQUIPMENT**

For model application see Option Section

	Wt	Number		Wt	Number
AXLE, 2-SPEED REAR: Full-floating; 13000 lb capacity; Hypoid primary gears.			2 quart capacity -----	15F	237
6.13 and 8.10 ratios -----	104R	202	PLATE, IDENTIFICATION:		
6.70 and 8.86 ratios -----	104R	201	1-1/2 Ton Special -----	*	402
COLORS, VEHICLE: Solid -----	*	234	SHOCK ABSORBERS, FRONT:		
CRANKCASE VENTILATION: Vac-operated with filtered air from oil bath air cleaner ---	*	217	Direct double-acting type,		
ENGINE, HEAVY DUTY:			1-3/8 diameter piston-----	16F	200
Jobmaster, 261 cu. in. displ			SPRINGS, REAR: Two stage 11-leaf;		
Gross HP, 135 @ 4000 RPM			5600 lb (ea) capacity at ground--	Minus 75R	268
Gross Torque, 220 ft lb @ 2000 RPM ---	*	225	TANK, VACUUM RESERVE:		
GENERATOR: Including voltage and current regulator, and pulley for high output			1000 cu.in. capacity-----	6F, 6R	281
40 amp -----	*	326	TIRES, MAXIMUM: RPO 291 mandatory		
50 amp -----	*	326	Front, 8.25-20-10pr; 2900 lb (ea)		
55 amp -----	27F	326	capacity-----	40F	343
55 amp, low cut-in -----	24F	326	Dual Rear, 9.00-20-10pr; 3450 lb (ea)		
GOVERNOR: Range 2300-3200 RPM;			capacity-----	150R	312
Heavy Duty Engine, 2400-3400 RPM ----	*	241	VACUUM BOOSTER AND FUEL PUMP ---	*	340
OIL FILTER: AC make,,			WHEELS: (20x6.5) For 8.25 or 9.00x20 tires;		
1 quart capacity -----	8F	237	5 Wheels (For fleet users only)-----	25R	291
			7 Wheels-----	10F, 23R	291
			WINDSHIELD WIPERS: (6112 only)		
			Dual, Electric-----	*	320

\*-Weight is less than 10 pounds

CHASSIS AND BODY DIMENSIONS

Model 6103 (6103S) Cab Chassis

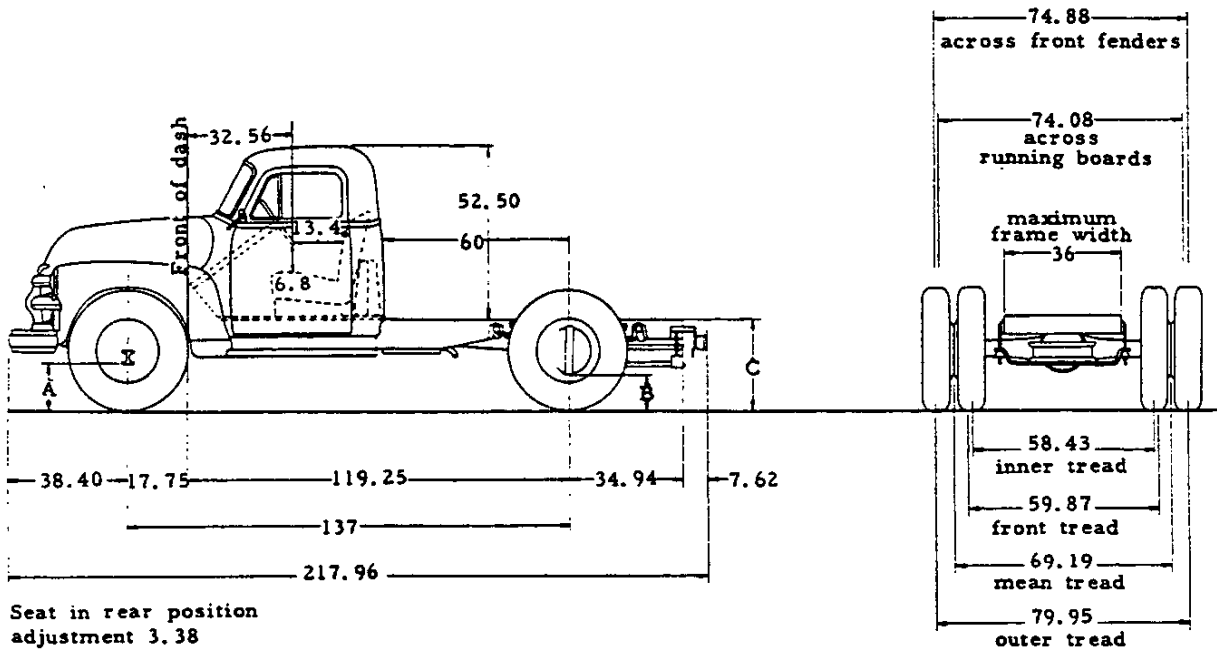

Seat in rear position  
adjustment 3.38

Equipment	Height Without Body and Payload		
	A	B	C
Standard	12.08	10.24	33.88
Minimum for Max GVW	12.08	10.78	34.57

To determine loaded and unloaded heights, body specifications must be known. Minimum tire equipment for max GVW is 7.50-20-8pr front and 8.25-20-10 dual rr.

VEHICLE WEIGHTS AND LOAD DISTRIBUTION

MODEL	WITH STANDARD EQUIPMENT						WITH MINIMUM EQUIPMENT FOR MAXIMUM GVW			
	Shipping			Curb			Body and Payload	Payload Distribution		Body Length
	Front	Rear	Total	Front	Rear	Total		Front	Rear	
6103(S)	2465	2090	4555	2560	2205	4765	11200	7%	93%	96
								5%	95%	102
								3%	97%	108

10-29-54

114-MODEL 6103 (6103S) DATA

CHEVROLET 1955 SPECIFICATIONS-TRUCK

## MODEL 6103 (6103S) HEAVY DUTY CAB CHASSIS

2 TON (1-1/2 Ton Special) NOMINAL RATING --- 137 WHEELBASE --- 16000 lb (Special, 15000lb) MAXIMUM GVW

### STANDARD EQUIPMENT

<p>AIR CLEANER --- AC make, oil bath type, 1 qt capacity                  AXLE, FRONT ----- 1-beam type; 4500 lb capacity                  AXLE, REAR ----- Full-floating type; 13000 lb capacity;                                                  hypoid gears; 6.17 ratio                  BATTERY ----- 15 plate; 100 amp hr capacity                  BRAKES:                    PARKING --- Hand-operated on prop shaft; 35 sq. in.                    SERVICE ----- Hydraulic type; 4-wheel; 375 sq. in.                    FRONT ----- 14 x 2-1/2; 134 sq. in. area                    REAR ----- 15 x 4; 241 sq. in. area                    BOOSTER (Hydraulic) ----- Long stroke, 7 dia;                    vacuum-operated                  BUMPER, FRONT ----- Rigid, channel type; painted                  CAB ----- All-steel; welded; flexibly mounted                  CLUTCH --- Diaphragm spring, single disc type; 11 dia;                                                  123.7 sq. in. area; 282 ft lb capacity                  COLOR, BASIC VEHICLE ----- Juniper Green                  COOLING SYSTEM --- Cellular radiator core; 4 lb                                                  press. cap. 407 sq. in. frontal                                                  area; 18 quart capacity                  DISPATCH BOX ----- 13-1/2 x 5-1/2 x 8-1/2                  DOME LIGHT ----- Above rear window                  DRIVE SYSTEM ----- Hotchkiss                  PROPELLER SHAFTS ----- Two                  PROPELLER SHAFT BRG SUPPORTS ----- One                  UNIVERSAL JOINTS ----- Three                  ENGINE ----- Loadmaster; 235.5 cu. in. displ                  GROSS HP ----- 112 @ 3700 RPM                  GROSS TORQUE ----- 200 ft lb @ 2000 RPM                  FENDERS ----- Front only</p>	<p>FRAME ----- Ladder type with 5 cross members,                                                  channel side rails 8-7/8 x 2-7/8 x 1/4;                                                  section modulus 8.80 in.<sup>3</sup>                  FUEL TANK ----- Back of seat in cab; 17-1/2 gal cap.                  GENERATOR ----- 45 amp maximum rate                  LIGHTS ----- 2 head, 2 parking, and 1 tail and stop                  MIRROR, REAR VIEW --- LH; long adjustable bracket                  RUNNING BOARDS ----- Short                  SEAT ----- Full width                  SPARE WHEEL CARRIER ----- Underslung at rear                  SPRINGS                    FRONT ----- Semi-elliptic; 9-leaf, 40 x 2;                                                  2200 lb (ea) capacity at ground                    REAR ----- Semi-elliptic; 7800 lb (ea) cap. at ground                      MAIN ----- 11-leaf, 46 x 2-1/2                      AUXILIARY ----- 6-leaf, 31 x 2-1/2                  STEERING GEAR ----- Recirculating-ball type; 27.76                                                  ratio; 18 dia wheel                  SUNSHADE ----- Adjustable; for driver                  TIRES ----- Front and dual rear; 7.50-20-8pr;                                                  2375 lb (ea) capacity                  TOOLS ----- 8250 lb capacity jack; tire changing iron;                                                  wheel wrench                  TOOL BOX ----- Under seat; 50 x 19 x 6                  TRANSMISSION --- 4-Speed, Synchro-mesh; shift lever                                                  on transmission; provision for                                                  power take-off on left side                  VENTILATORS ----- Top of cowl and ventipanes                  WHEELS ----- 7; wide-base rim; 20 x 6.0                  WINDSHIELD WIPERS ----- Dual; cowl mounted</p>
---	---

### OPTIONAL EQUIPMENT

For model application see Option Section

	Wt	Number	Wt	Number
AXLES, 2-SPEED REAR: Full-floating; 13000 lb capacity; Hypoid primary gears.				
6.13 and 8.10 ratios ----- 104R	202			
6.70 and 8.86 ratios ----- 104R	201			
COLORS, VEHICLE: Solid ----- *	234			
CORNER WINDOWS, CAB				
Clear or tinted ----- *	387			
CRANKCASE VENTILATION: Vac-operated with filtered air from oil bath air cleaner --- *	217			
ENGINE, HEAVY DUTY:				
Jobmaster, 261 cu. in. displ				
Gross HP, 135 @ 4000 RPM				
Gross Torque, 220 ft lb @ 2000 RPM --- *	225			
GENERATOR: Including voltage and current regulator, and pulley for high output				
40 amp ----- *	326			
50 amp ----- *	326			
55 amp ----- 27F	326			
55 amp, low cut-in ----- 24F	326			
GLASS EQUIPMENT, BODY:				
Tinted ----- *	399			
GOVERNOR: Range 2300-3200 RPM;				
Heavy Duty Engine, 2400-3400 RPM ---- *	241			
MIRROR, REAR VIEW:				
Short, RH or LH ----- *	210			
Long, RH ----- *	210			
	*-Weight is less than 10 pounds			
OIL FILTER: AC make,				
1 quart capacity ----- 8F		237		
2 quart capacity ----- 15F		237		
PLATE, IDENTIFICATION:				
1-1/2 Ton Special ----- *		402		
SEAT EQUIPMENT: Unison ----- *		264		
SHOCK ABSORBERS, FRONT:				
Direct double-acting type; 1-3/8				
dia piston ----- 16F		200		
SIDE DOOR KEY LOCK:				
Left side ----- *		395		
SPRINGS, REAR:				
Two-stage 11-leaf; 5600 (ea) capacity				
at ground ----- Minus 75R		268		
TANK, VACUUM RESERVE:				
1000 cu.in. capacity ----- 6F, 6R		281		
TIRES, MAXIMUM: RPO 291 mandatory				
Front, 8.25-20-10 pr; 2900 lb (ea)				
capacity ----- 40F		343		
Dual Rear, 9.00-20-10 pr; 3450 lb (ea)				
capacity ----- 150R		312		
VACUUM BOOSTER AND FUEL PUMP*		340		
WHEELS: (20 x 6.5) For 8.25 or 9.00 x 20 tires				
5 Wheels (For fleet users only) --- 25R		291		
7 Wheels ----- 10R, 25R		291		
WINDSHIELD WIPERS: Dual, electric -*		320		



CHASSIS AND BODY DIMENSIONS

Model 6108 (6108S) Platform Truck

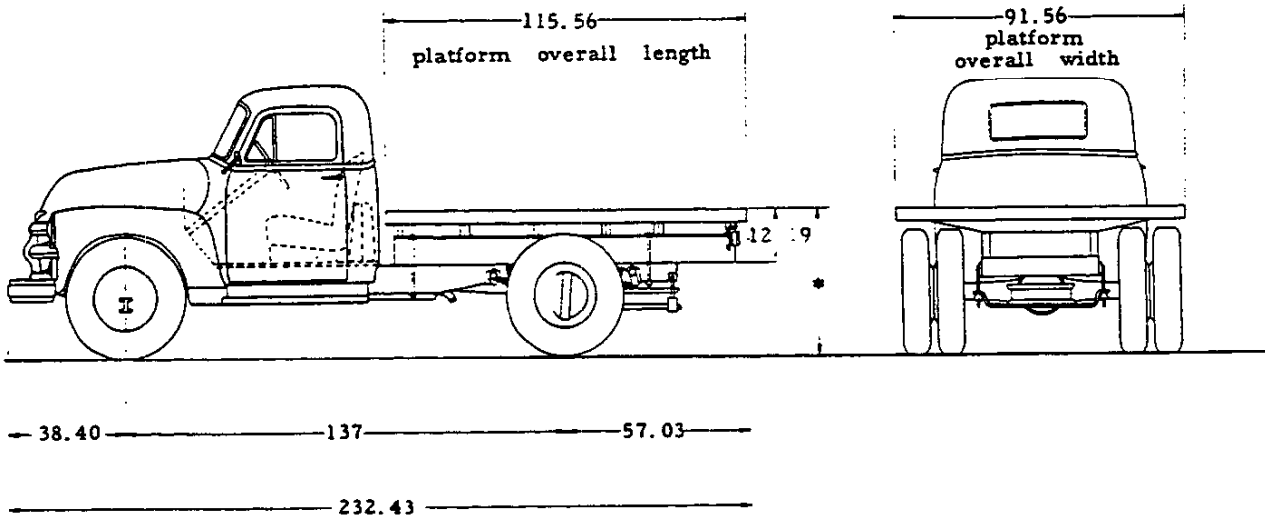

Equipment	*Platform Height		Tires	
	Loaded	Unloaded	Front	Rear
Standard	42.98	46.55	7.50-20-8pr	7.50-20-8pr dual
Minimum for Max GVW	43.57	47.31	7.50-20-8pr	8.25-20-10pr dual

Model 6109 (6109S) Stake Truck

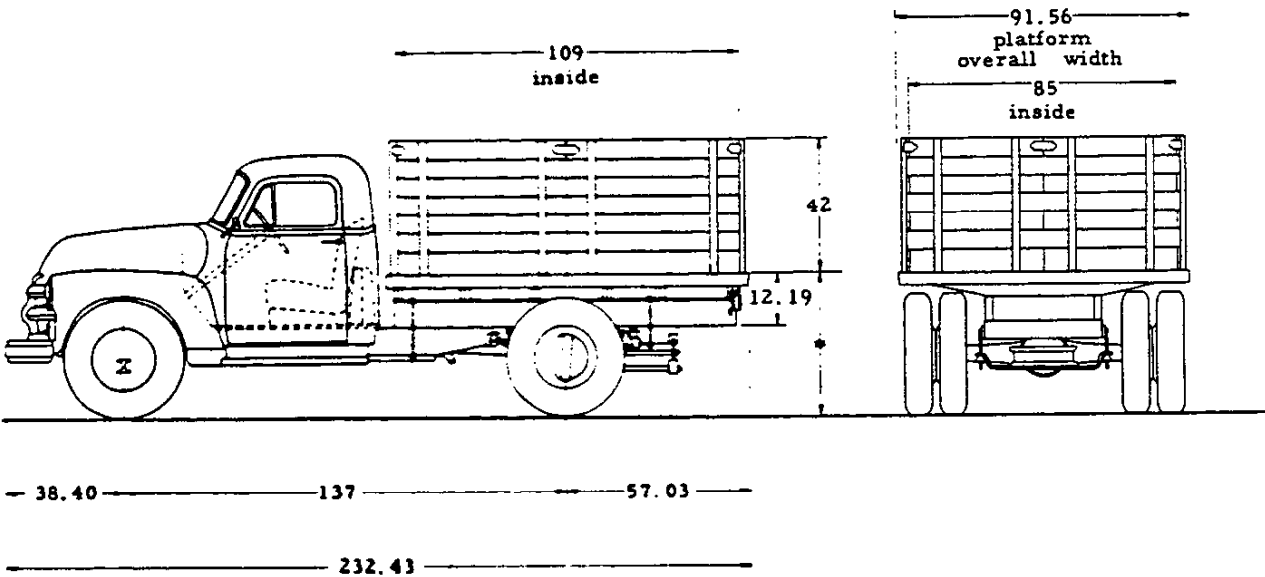

Equipment	*Platform Height		Tires	
	Loaded	Unloaded	Front	Rear
Standard	42.98	46.40	7.50-20-8pr	7.50-20-8pr dual
Minimum for Max GVW	43.57	47.14	7.50-20-8pr	8.25-20-10pr dual

VEHICLE WEIGHTS AND LOAD DISTRIBUTION

MODEL	WITH STANDARD EQUIPMENT						WITH MINIMUM EQUIPMENT FOR MAXIMUM GVW			
	Shipping			Curb			Body and Payload	Payload Distribution		Body Length
	Front	Rear	Total	Front	Rear	Total		Front	Rear	
6108(S)⊙	2455	2570	5025	2545	2685	5230	10700	0%	100%	115.56
6109(S)⊙	2465	2860	5325	2555	2975	5530	10400	1%	99%	109.00

⊙ - Estimated weight

10-29-54

116-MODELS 6108 (6108S), 6109 (6109S) DATA

CHEVROLET 1955 SPECIFICATIONS—TRUCK

**MODEL 6108 (6108S) HEAVY DUTY PLATFORM TRUCK  
MODEL 6109 (6109S) HEAVY DUTY STAKE TRUCK**

2 TON (1-1/2 Ton Special) NOMINAL RATING --- 137 WHEELBASE --- 16000lb (Special, 15000lb) MAXIMUM GVW  
STANDARD EQUIPMENT

AIR CLEANER ----- AC make, oil bath type 1 quart capacity	ENGINE ----- Loadmaster 235.5 cu. in. displ GROSS HP ----- 112 @ 3700 RPM GROSS TORQUE ----- 200 ft lb @ 2000 RPM
AXLE, FRONT ----- 1-beam type; 4500 lb capacity	FENDERS ----- Front only
AXLE, REAR ----- Full-floating type; 13000 lb capacity; hypoid gears; 6.17 ratio	FRAME ----- Ladder type with 5 cross members, channel side rails 8-7/8 x 2-7/8 x 1/4; section modulus 8.80 in. <sup>3</sup>
BATTERY ----- 15 plate; 100 amp hr capacity	FUEL TANK ----- Back of seat in cab; 17-1/2 gal cap;
BODY --- Nominal 9-foot wood platform body with steel skid strips. Steel cross sills, and full length wood side sills. Entire platform is bound by a steel channel-type rub rail with stake pocket integrally formed. 6109 is equipped with a 42 high stake rack.	GENERATOR ----- 45 amp maximum rate
BRAKES	LIGHTS ----- 2 Head, 2 parking, and 1 tail and stop
PARKING --- Hand-operated on prop shaft; 35 sq. in.	MIRROR, REAR VIEW ----- LH; long adjustable bracket
SERVICE ----- Hydraulic type; 4-wheel; 375 sq. in.	RUNNING BOARDS ----- Short
FRONT ----- 14 x 2-1/2; 134 sq. in. area	SEAT ----- Full width
REAR ----- 15 x 4; 241 sq. in. area	SPARE WHEEL CARRIER ----- Underslung at rear
BOOSTER (Hydraulic) ----- Long stroke, 7 dia; vacuum-operated	SPRINGS
BUMPER, FRONT ----- Rigid, channel-type; painted	FRONT ----- Semi-elliptic 9-leaf, 40 x 2; 2200 lb (ea) cap. at ground
CAB ----- All-steel; welded; flexibly mounted	REAR ----- Semi-elliptic, 7800 lb (ea) cap. at ground
CLUTCH --- Diaphragm spring, single disc type; 11 dia; 123.7 sq. in. area; 282 ft lb capacity	MAIN ----- 11-leaf, 46 x 2-1/2
COLOR, BASIC VEHICLE ----- Juniper Green	AUXILIARY ----- 6-leaf, 31 x 2-1/2
COOLING SYSTEM ----- Cellular radiator core, 4 lb press. cap; 407 sq. in. frontal area; 18 quart capacity	STEERING GEAR ----- Recirculating-ball type; 27.76 ratio; 18 dia wheel
DISPATCH BOX ----- 13-1/2 x 5-1/2 x 8-1/2	SUNSHADE ----- Adjustable; for driver
DOME LIGHT ----- Above rear window	TIRES ----- Front and dual rear; 7.50-20-8pr; 2375 lb (ea) capacity
DRIVE SYSTEM ----- Hotchkiss	TOOLS ----- 8250 lb capacity jack; tire changing iron; wheel wrench
PROPELLER SHAFTS ----- Two	TOOL BOX ----- Under seat; 50 x 19 x 6
PROPELLER SHAFT BRG SUPPORTS ----- One	TRANSMISSION --- 4-Speed Synchro-mesh; shift lever on transmission; provision for power take-off on left side
UNIVERSAL JOINTS ----- Three	VENTILATORS ----- Top of cowl and ventipanes

**OPTIONAL EQUIPMENT**

For model application see Option Section

	Wt	Number		Wt	Number
AXLE, 2-SPEED REAR: Full-floating, 13000 lb capacity; Hypoid primary gears.			OIL FILTER: AC make		
6.13 and 8.10 ratios ----- 104R	202		1 quart capacity ----- 8F	237	
6.70 and 8.86 ratios ----- 104R	201		2 quart capacity ----- 15F	237	
COLORS, VEHICLE: Solid ----- *	234		PLATE, IDENTIFICATION:		
CORNER WINDOWS, CAB:			1-1/2 Ton Special ----- *	402	
Clear or tinted ----- *	387		SEAT EQUIPMENT: Unison ----- *	264	
CRANKCASE VENTILATION: Vac-operated with filtered air from oil bath air cleaner --- *	217		SHOCK ABSORBERS, FRONT:		
ENGINE, HEAVY DUTY:			Direct double-acting type, 1-3/8 diameter piston ----- 16F	200	
Jobmaster, 261 cu. in. displ			SIDE DOOR KEY LOCK		
Gross HP, 135 @ 4000 RPM			Left side ----- *	395	
Gross Torque, 220 ft lb @ 2000 RPM --- *	225		SPRINGS, REAR		
GENERATOR: Including voltage and current regulator and pulley for high output			11-leaf, two-stage; 5600 lb (ea) capacity at ground ----- Minus 75R	268	
40 amp ----- *	326		TANK, VACUUM RESERVE:		
50 amp ----- *	326		1000 cu. in. capacity ----- 6F, 6R	281	
55 amp ----- 27F	326		TIRES, MAXIMUM: (RPO 291 mandatory)		
55 amp, low cut-in ----- 24F	326		Front and Dual Rear; 8.25-20-12pr; 3105 lb (ea) capacity ----- 56F, 116R	344	
GLASS EQUIPMENT, BODY:			VACUUM BOOSTER AND FUEL PUMP --- *	340	
Tinted ----- *	399		WHEELS (20 x 6.5)		
GOVERNOR: Range, 2300-3200 RPM;			For 8.25 x 20 tires		
Heavy Duty Engine, 2400-3400 RPM --- *	241		5 Wheels (For fleet users only) ----- 25R	291	
MIRROR, REAR VIEW:			7 Wheels ----- 10F, 25R	291	
Long, RH ----- *	210		WINDSHIELD WIPERS: Dual, Electric --- *	320	

\*--Weight is less than 10 pounds

10-29-54

**CHEVROLET 1955 SPECIFICATIONS—TRUCK**

**MODELS 6108 (6108S), 6109 (6109S) DATA-117**

**CHASSIS AND BODY DIMENSIONS**

Model 6402 (6402S) Flat Face Cowl Chassis  
 Model 6412 (6412S) Windshield Cowl Chassis

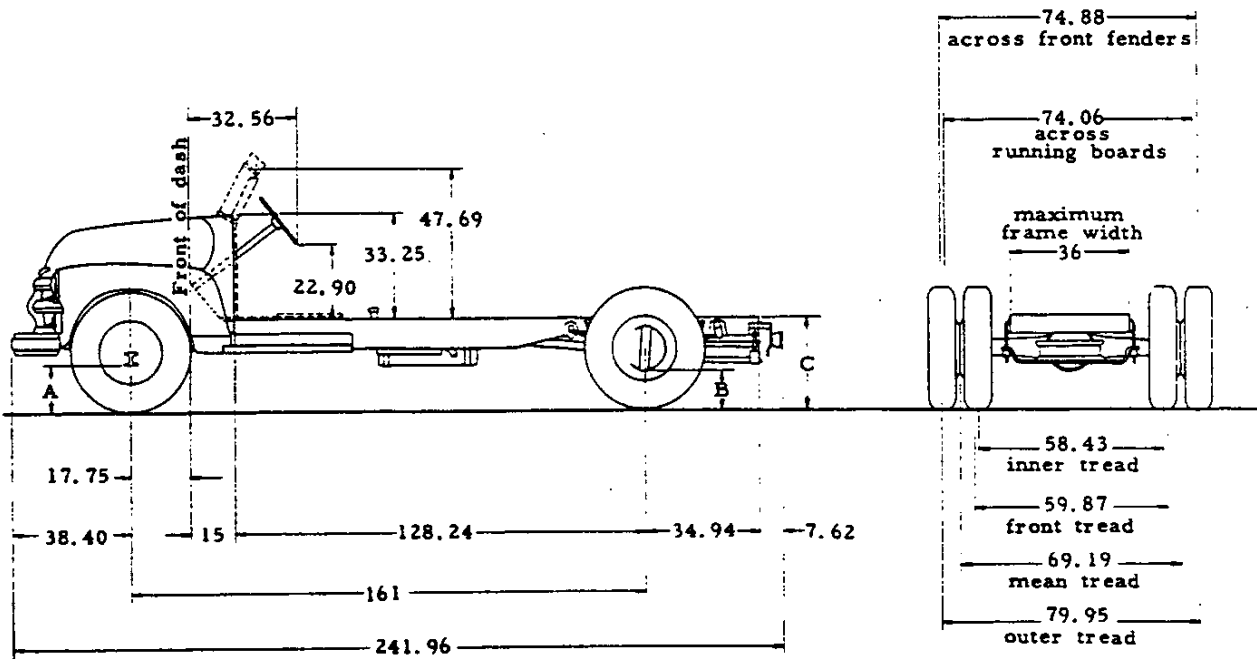

Equipment	Height Without Body and Payload		
	A	B	C
Standard	12.11	10.24	33.69
Minimum for Max GVW	12.11	10.78	34.32

To determine loaded and unloaded heights, body specifications must be known.  
 Minimum tire equipment for max GVW is 7.50-20-8pr front and 8.25-20-10 dual rr.

**VEHICLE WEIGHTS AND LOAD DISTRIBUTION**

MODEL	WITH STANDARD EQUIPMENT						WITH MINIMUM EQUIPMENT FOR MAXIMUM GVW			
	Shipping			Curb			Body and Payload	Payload Distribution		Body Length
	Front	Rear	Total	Front	Rear	Total		Front	Rear	
6402(S)	2240	1935	4175	2305	2080	4385	11550	Determined by style, length and weight of body.		
6412(S)⊕	2315	1925	4240	2380	2070	4450	11500			

⊕ - Estimated Weight

10-29-54

118 - MODELS 6402 (6402S), 6412 (6412S) DATA

CHEVROLET 1955 SPECIFICATIONS—TRUCK

**MODEL 6402 (6402S) HEAVY DUTY FLAT FACE COWL CHASSIS  
MODEL 6412 (6412S) HEAVY DUTY WINDSHIELD COWL CHASSIS**

2 TON (1-1/2 Ton Special) NOMINAL RATING -- 161 WHEELBASE -- 16000 lb (Special, 15000 lb) MAXIMUM GVW

**STANDARD EQUIPMENT**

AIR CLEANER ---AC make; oil bath type; 1 qt capacity  
 AXLE, FRONT ----- I-beam type; 4500 lb capacity  
 AXLE, REAR -- Full-floating type; 13000 lb capacity;  
                   Hypoid gears; 6.17 ratio  
 BATTERY ----- 15 plate; 100 amp hr capacity  
**BRAKES**  
   **PARKING** ---Hand-operated on prop shaft; 35 sq. in.  
   **SERVICE** ----- Hydraulic type; 4-wheel; 375 sq. in.  
     **FRONT** ----- 14 x 2-1/2; 134 sq. in. area  
     **REAR** ----- 15 x 4; 241 sq. in. area  
   **BOOSTER** (hydraulic) ----- Long stroke; 7 dia;  
   vacuum-operated  
**BUMPER, FRONT** ----- Rigid, channel-type; painted  
**CLUTCH**--Diaphragm spring; single disc type; 11 dia;  
           123.7 sq. in. area; 282 ft lb capacity  
**COLOR, BASIC VEHICLE** ----- Juniper Green  
**COOLING SYSTEM**-----Cellular radiator core; 4 lb  
                                   press cap. 407 sq in frontal  
                                   area; 18 quart capacity  
**DISPATCH BOX** --- 6402 -- 13-7/8 x 4-3/4 x 8-1/4;  
                           6412 -- 13-1/2 x 5-1/2 x 8-1/2  
**DRIVE SYSTEM** ----- Hotchkiss  
**PROPELLER SHAFTS** ----- Two  
**PROPELLER SHAFT BRG SUPPORTS** ----- One  
**UNIVERSAL JOINTS** ----- Three  
**ENGINE** ----- Loadmaster; 235.5 cu. in. displ  
   **GROSS HP** ----- 112 @ 3700 RPM  
   **GROSS TORQUE** ----- 200 ft lb @ 2000 RPM  
**FENDERS** ----- Front only

**FRAME** ----- Ladder type with 6 cross members,  
                           channel side rails 8-7/8 x 2-7/8 x 1/4;  
                           section modulus 8.80 in<sup>3</sup>  
**FUEL TANK**--Outside of frame on right; 18 gal cap.  
**GENERATOR** ----- 45 amp maximum rate  
**LIGHTS** ----- 2 head, 2 parking, and 1 tail and stop;  
**RUNNING BOARDS** ----- Short  
**SEAT RISER** ----- 6412 only  
**SPARE WHEEL CARRIER** ----- Underslung at rear  
**SPRINGS**  
   **FRONT** ----- Semi-elliptic; 9-leaf, 40 x 2;  
                           2200 lbs (ea) capacity at ground  
   **REAR**--- Semi-elliptic; 7800 lb (ea) cap. at ground  
     **MAIN** ----- 11-leaf, 46 x 2-1/2  
     **AUXILIARY** ----- 6-leaf, 31 x 2-1/2  
**STEERING GEAR** ----- Recirculating-ball type; 27.76  
                           ratio; 18-inch dia wheel  
**TIRES** ----- Front and dual rear; 7.50-20-8pr;  
                           2375 lb (ea) capacity  
**TOOLS**----- 8250 lb capacity jack; tire changing iron;  
                           wheel wrench  
**TOOL BOX** (6412 only) ----- 50 x 19 x 2-3/8  
**TRANSMISSION** -- 4-speed, synchro-mesh; shift lever  
                           on transmission; provision for  
                           power take-off on left side  
**VENTILATOR** ----- Top of cowl  
**WHEELS** ----- 7; wide-base rim;  
                           20 x 6.0  
**WINDSHIELD WIPERS** (6412 only) --Dual; cowl mounted

**OPTIONAL EQUIPMENT**

For model application see Option Section

	Wt	Number		Wt	Number
AXLE, 2-SPEED REAR: Full-floating; 13000 lb capacity; hypoid primary gears			2 quart capacity -----	15F	237
6.13 and 8.10 ratios -----	104R	202	PLATE, IDENTIFICATION:		
6.70 and 8.86 ratios -----	104R	201	1-1/2 Ton Special ----- *		402
COLORS, VEHICLE: Solid ----- *		234	SHOCK ABSORBERS: FRONT,		
CRANKCASE VENTILATION: Vac-operated with filtered air from oil bath cleaner ----- *		217	Direct double-acting, 1-3/8 diameter piston -----	16F	200
ENGINE, HEAVY DUTY:			SPRINGS, REAR: Two-stage, 11-leaf; 5600 lb (ea) capacity at ground---Minus 75R		268
Jobmaster, 261 cu. in. displ			TANK, VACUUM RESERVE:		
Gross HP, 135 @ 4000 RPM			1000 cu. in. capacity -----	6F, 6R	281
Gross torque, 220 ft lb @ 2000 RPM--- *	225		TIRES, MAXIMUM: RPO 291 mandatory,		
GENERATOR: Including voltage and current regulator, and pulley for high output			Front, 8.25-20-10pr; 2900 lb (ea) capacity -----	40F	343
40 amp ----- *	326		Dual Rear, 9.00-20-10pr; 3450 lb (ea) capacity -----	150R	312
50 amp ----- *	326		VACUUM BOOSTER AND FUEL PUMP----- *		340
55 amp -----	27F	326	WHEELS: (20 x 6.5)		
55 amp, low cut-in -----	24F	326	For 8.25 or 9.00 x 20 tires:		
GOVERNOR:			5 Wheels (For fleet users only) -----	25R	291
Range 2300-3200 RPM:			7 Wheels -----	10F, 25R	291
Heavy Duty engine, 2400-3400 RPM --- *	241		WINDSHIELD WIPERS: (6412 only)		
OIL FILTER: AC make;			Dual, Electric ----- *		320
1 quart capacity -----	8F	237			

\* - Weight is less than 10 pounds

CHASSIS AND BODY DIMENSIONS

Model 6403 (6403S) Cab Chassis

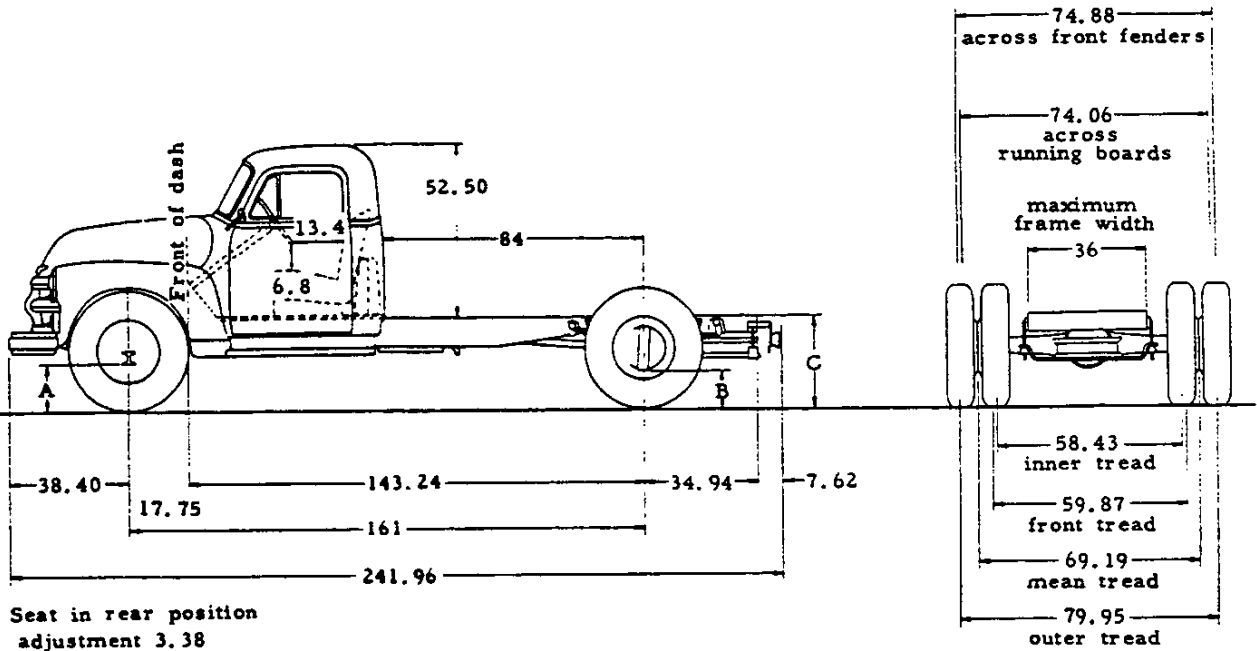

Equipment	Height Without Body and Payload		
	A	B	C
Standard	12.06	10.22	33.68
Minimum for Max GVW	12.06	10.76	34.34

To determine loaded and unloaded heights, body specifications must be known. Minimum tire equipment for max GVW is 7.50-20-8pr front and 8.25-20-10pr dual rr.

VEHICLE WEIGHTS AND LOAD DISTRIBUTION

MODEL	WITH STANDARD EQUIPMENT						WITH MINIMUM EQUIPMENT FOR MAXIMUM GVW			
	Shipping			Curb			Body and Payload	Payload Distribution		Body Length
	Front	Rear	Total	Front	Rear	Total		Front	Rear	
6403 (S)	2545	2085	4630	2645	2195	4840	11100	14%	86%	120
								10%	90%	132
								6%	94%	144

10-29-54

120-MODEL 6403 (6403S) DATA

CHEVROLET 1955 SPECIFICATIONS—TRUCK

## MODEL 6403 (6403S) HEAVY DUTY CAB CHASSIS

2 TON (1-1/2 Ton Special) NOMINAL RATING --- 161 WHEELBASE --- 16000 lb (Special, 15000 lb) MAXIMUM GVW

### STANDARD EQUIPMENT

<p>AIR CLEANER --- AC make, oil bath type; 1 qt capacity          AXLE, FRONT ----- 1-beam type; 4500 lb capacity          AXLE, REAR ----- Full-floating type; 13000 lb capacity;                                          hypoid gears; 6.17 ratio          BATTERY ----- 15 plate; 100 amp hr capacity  <b>BRAKES</b>            <b>PARKING</b> --- Hand-operated on prop shaft; 35 sq. in.            <b>SERVICE</b> ----- Hydraulic type; 4-wheel; 375 sq. in.              <b>FRONT</b> ----- 14 x 2-1/2; 134 sq. in. area              <b>REAR</b> ----- 15 x 4; 241 sq. in. area            <b>BOOSTER (Hydraulic)</b> ----- Long stroke; 7 dia            vacuum-operated  <b>BUMPER, FRONT</b> ----- Rigid, channel-type; painted  <b>CAB</b> ----- All-steel; welded; flexibly mounted  <b>CLUTCH</b> -- Diaphragm spring, single disc type; 11 dia;                                  123.7 sq. in. area; 282 ft lb capacity  <b>COLOR, BASIC VEHICLE</b> ----- Juniper Green  <b>COOLING SYSTEM</b> --- Cellular radiator core; 4 lb                                          press. cap; 407 sq. in. frontal                                          area; 18 quart capacity  <b>DISPATCH BOX</b> ----- 13-1/2 x 5-1/2 x 8-1/2  <b>DOME LIGHT</b> ----- Above rear window  <b>DRIVE SYSTEM</b> ----- Hotchkiss            <b>PROPELLER SHAFTS</b> ----- Two            <b>PROPELLER SHAFT BRG SUPPORTS</b> ----- One            <b>UNIVERSAL JOINTS</b> ----- Three  <b>ENGINE</b> ----- Loadmaster; 235.5 cu. in. displ  <b>GROSS HP</b> ----- 112 @ 3700 RPM  <b>GROSS TORQUE</b> ----- 200 ft lb @ 2000 RPM  <b>FENDERS</b> ----- Front only</p>	<p><b>FRAME</b> ----- Ladder type with 6 cross members,                                          channel side rails 8-7/8 x 2-7/8 x 1/4;                                          section modulus 8.80 in<sup>3</sup>  <b>FUEL TANK</b> ----- Back of seat in cab; 17-1/2 gal cap.  <b>GENERATOR</b> ----- 45 amp maximum rate  <b>LIGHTS</b> ----- 2 Head, 2 parking, and 1 tail and stop  <b>MIRROR, REAR VIEW</b> ----- LH, long adjustable bracket  <b>RUNNING BOARDS</b> ----- Short  <b>SEAT</b> ----- Full width  <b>SPARE WHEEL CARRIER</b> ----- Underslung at rear  <b>SPRINGS</b>            <b>FRONT</b> ----- Semi-elliptic 9-leaf, 40 x 2;                                          2200 lb (ea) cap. at ground            <b>REAR</b> -- Semi-elliptic, 7800 lb (ea) capacity at ground              <b>MAIN</b> ----- 11-leaf, 46 x 2-1/2              <b>AUXILIARY</b> ----- 6-leaf, 31 x 2-1/2  <b>STEERING GEAR</b> ----- Recirculating-ball type, 27.76                                          ratio; 18 dia wheel  <b>SUNSHADE</b> ----- Adjustable, for driver  <b>TIRES</b> ----- Front and Dual Rear, 7.50-20-8pr;                                          2375 lb (ea) capacity  <b>TOOLS</b> ----- 8250 lb capacity jack; tire changing iron;                                          wheel wrench  <b>TOOL BOX</b> ----- Under seat; 50 x 19 x 6  <b>TRANSMISSION</b> --- 4-Speed Synchro-mesh; Shift-lever                                          on transmission; provision for                                          power take-off on left side  <b>VENTILATORS</b> ----- Top of cowl and ventipanes  <b>WHEELS</b> ----- 7; wide-base rim; 20 x 6.0  <b>WINDSHIELD WIPERS</b> ----- Dual; cowl mounted</p>
---	---

### OPTIONAL EQUIPMENT

For model application see Option Section

	Wt	Number		Wt	Number
AXLE, 2-SPEED REAR: Full-floating; 13000 lb capacity; hypoid primary gears.					
6.13 and 8.10 ratios ----- 104R		202			
6.70 and 8.86 ratios ----- 104 R		201			
COLORS, VEHICLE: Solid ----- *		234			
CORNER WINDOWS, CAB ----- *		387			
CRANKCASE VENTILATION: Vac-operated with filtered air from oil bath air cleaner --- *		217			
ENGINE, HEAVY DUTY: Jobmaster, 261 cu. in. displ Gross HP 135, @ 4000 RPM Gross Torque, 220 ft lb @ 2000 RPM --- *		225			
GENERATOR: Including voltage and current regulator, and pulley, for high output					
40 amp ----- *		326			
50 amp ----- *		326			
55 amp ----- *		27F			
55 amp, low cut-in ----- *		24F			
GLASS EQUIPMENT, BODY: Tinted ----- *		399			
GOVERNOR: Range, 2300-3200 RPM; Heavy Duty Engine, 2400-3400 RPM ----- *		241			
MIRROR, REAR VIEW: Short, RH or LH ----- *		210			
Long, RH ----- *		210			
OIL FILTER: AC make, 1 quart capacity ----- 8F		237			
2 quart capacity ----- 15F		237			
PLATE, IDENTIFICATION: 1-1/2 Ton Special ----- *		402			
SEAT EQUIPMENT: Unison ----- *		264			
SHOCK ABSORBERS: Front, Direct double-acting type; 1-3/8 dia piston ----- 16F		200			
SIDE DOOR KEY LOCK, LH ----- *		395			
SPRINGS, REAR: Two-stage, 11-leaf; 5600 lb (ea) capacity at ground ----- Minus 75R		268			
TANK, VACUUM RESERVE: 1000 cu. in. capacity ----- 6F, 6R		281			
TIRES, MAXIMUM (RPO 291 mandatory) Front, 8.25-20-10pr; 2900 lb (ea) capacity ----- 40F		343			
Dual Rear, 9.00-20-10pr; 3450 lb (ea) capacity ----- 150R		312			
VACUUM BOOSTER AND FUEL PUMP --- *		340			
WHEELS: (20 x 6.5) For 8.25 or 9.00 x 20 tires 5 Wheels (For fleet users only) ----- 25R		291			
7 Wheels ----- 10F, 25R		291			
WINDSHIELD WIPERS: Dual, Electric --- *		320			

\* - Weight is less than 10 pounds

10-29-54

CHEVROLET 1955 SPECIFICATIONS—TRUCK

MODEL 6403 (6403S) DATA - 121

CHASSIS AND BODY DIMENSIONS

Model 6408 (6408S) Platform Truck

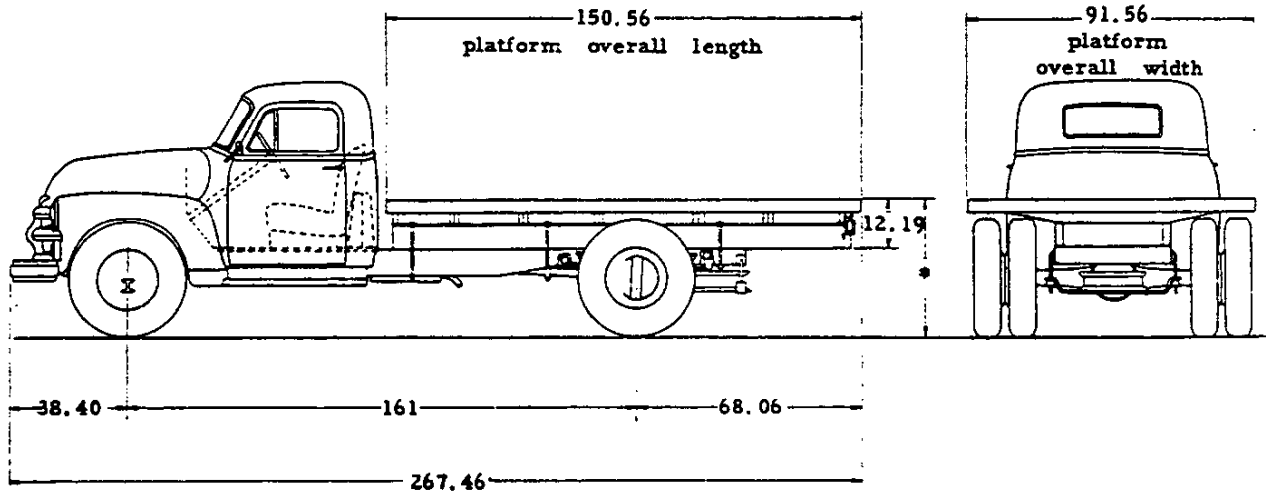

Equipment	*Platform Height		Tires	
	Loaded	Unloaded	Front	Rear
Standard	43.27	46.47	7.50-20-8pr	7.50-20-8pr dual
Minimum for Max GVW	43.80	47.25	7.50-20-8pr	8.25-20-10pr dual

Model 6409 (6409S) Stake Truck

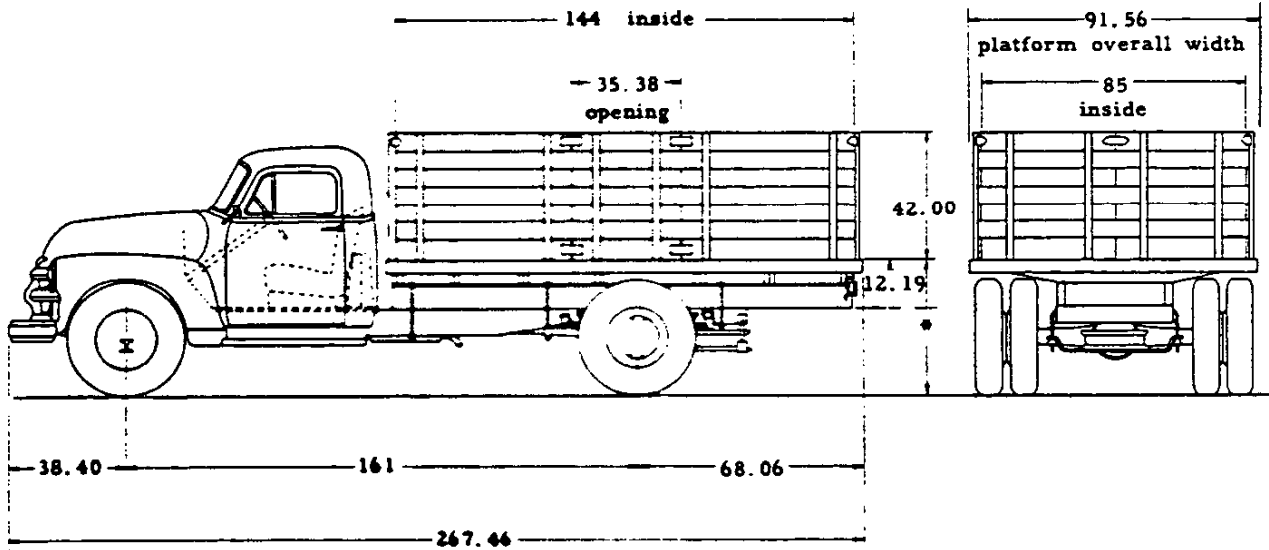

Equipment	*Platform Height		Tires	
	Loaded	Unloaded	Front	Rear
Standard	43.27	46.30	7.50-20-8pr	7.50-20-8pr dual
Minimum for Max GVW	43.80	47.08	7.50-20-8pr	8.25-20-10pr dual

VEHICLE WEIGHTS AND LOAD DISTRIBUTION

MODEL	WITH STANDARD EQUIPMENT						WITH MINIMUM EQUIPMENT FOR MAXIMUM GVW			
	Shipping			Curb			Payload	Payload Distribution		Body Length
	Front	Rear	Total	Front	Rear	Total		Front	Rear	
6408 (S)	2565	2770	5335	2665	2880	5545	10400	4%	96%	150.56
6409 (S)	2620	3025	5645	2720	3135	5855	10100	5%	95%	144.00

10-24-54

122-MODELS 6408 (S), 6409 (S), DATA

CHEVROLET 1955 SPECIFICATIONS—TRUCK

**MODEL 6408 (6408S) HEAVY DUTY PLATFORM TRUCK  
MODEL 6409 (6409S) HEAVY DUTY STAKE TRUCK**

2 TON (1-1/2 Ton Special) NOMINAL RATING -- 161 WHEELBASE -- 16000 lb (Special, 15000 lb) MAXIMUM GVW  
STANDARD EQUIPMENT

AIR CLEANER---AC make, oil bath type, 1 qt capacity	FENDERS----- Front only
AXLE, FRONT----- I-beam type; 4500 lb capacity	FRAME----- Ladder type with 6 cross members
AXLE, REAR----- Full-floating type; 13000 lb capacity;	channel side rails, 8-7/8 x 2-7/8 x 1/4;
hypoid gears; 6.17 ratio	section modulus 8.80 in. <sup>3</sup>
BATTERY----- 15 plate; 100 amp hr capacity	FUEL TANK----- Back of seat in cab; 17-1/2 gal. cap.
BODY-----Nominal 12-foot wood platform body with	GENERATOR----- 45 amp maximum rate
steel skid strips. Steel cross sills, and full	LIGHTS----- 2 head, 2 parking, and
length wood side sills. Entire platform is	1 tail and stop
bound by a steel channel-type rub rail with	MIRROR, REAR VIEW----- LH; long adjustable bracket
stake pockets integrally formed. 6409 is	RUNNING BOARDS----- Short
equipped with 42 high stake rack.	SEAT----- Full width
BRAKES	SPARE WHEEL CARRIER ----- Underslung at rear
PARKING--- Hand operated, on prop shaft, 35 sq. in.	SPRINGS
SERVICE----- Hydraulic type; 4-wheel; 375 sq. in.	FRONT----- Semi-elliptic; 9-leaf, 40 x 2;
FRONT----- 14 x 2-1/2; 134 sq. in. area	2200 lb (ea) capacity at ground
REAR----- 15 x 4; 241 sq. in. area	REAR ----- Semi-elliptic; 7800 lb (ea) cap. at ground
BOOSTER (Hydraulic)----- Long stroke, 7 dia;	MAIN----- 11-leaf, 46 x 2-1/2
vacuum-operated	AUXILIARY----- 6-leaf, 31 x 2-1/2
BUMPER, FRONT----- Rigid, channel-type; painted	STEERING GEAR----- Recirculating-ball type; 27.76
CAB----- All-steel; welded; flexibly mounted	ratio; 18-inch dia wheel
CLUTCH---Diaphragm spring, single disc type; 11 dia;	SUNSHADE----- Adjustable; for driver
123.7 sq. in. area; 282 ft lb capacity	TIRES----- Front and dual rear; 7.50-20-8pr;
COLOR, BASIC VEHICLE----- Juniper Green	2375 lb (ea) capacity
COOLING SYSTEM----- Cellular radiator core, 4 lb	TOOLS----- 8250 lb capacity jack; tire changing iron;
press. cap. 407 sq. in. frontal	wheel wrench
area; 18 quart capacity	TOOL BOX----- Under seat; 50 x 19 x 6
DISPATCH BOX ----- 13-1/2 x 5-1/2 x 8-1/2	TRANSMISSION-4-speed, synchro-mesh; shift lever
DOME LIGHT----- Above rear window	on transmission; provision for power
DRIVE SYSTEM----- Hotchkiss	take-off on left side
PROPELLER SHAFTS----- Two	VENTILATORS----- Top of cowl and
PROPELLER SHAFT BRG SUPPORTS----- One	ventipanes
UNIVERSAL JOINTS----- Three	WHEELS----- Wide-base rim; 20 x 6.0;
ENGINE----- Loadmaster; 235.5 cu. in. displ	7 wheels
GROSS HP----- 112 @ 3700 RPM	WINDSHIELD
GROSS TORQUE----- 200 ft lb @ 2000 RPM	WIPERS----- Dual; cowl mounted

**OPTIONAL EQUIPMENT**

For model application see Option Section

	Wt	Number		Wt	Number
AXLE, 2-SPEED REAR: Full-floating; 13000 lb			OIL FILTER: AC make;		
capacity; hypoid primary gears			1 quart capacity ----- 8F		237
6.13 and 8.10 ratios----- 104R	202		2 quart capacity ----- 15F		237
6.70 and 8.86 ratios----- 104R	201		PLATE, IDENTIFICATION:		
COLORS, VEHICLE: Solid----- *	234		1-1/2 Ton Special ----- *		402
CORNER WINDOWS, CAB----- *	387		SEAT EQUIPMENT: Unison ----- *		264
CRANKCASE VENTILATION: Vac-operated with			SHOCK ABSORBERS, FRONT:		
filtered air from oil bath air cleaner---- *	217		Direct double-acting type; 1-3/8		
ENGINE, HEAVY DUTY:			dia piston ----- 16F		200
Jobmaster, 261 cu. in. displ			SIDE DOOR KEY LOCK: LH ----- *		395
Gross HP, 135 @ 4000 RPM			SPRINGS, REAR: Two-stage 11-leaf,		
Gross Torque, 220 @ 2000 RPM----- *	225		5600 lb (ea) cap. at ground ----- Minus 75R		268
GENERATOR: Including voltage and current			TANK, VACUUM RESERVE:		
regulator, and pulley for high output			1000 cu. in. capacity ----- 6F, 6R		281
40 amp----- *	326		TIRES, MAXIMUM: (RPO 291 mandatory)		
50 amp----- *	326		Front and Dual Rear, 8.25-20-12pr;		
55 amp----- 27F	326		3150 lb (ea) capacity ----- 56F, 116R		344
55 amp, Low cut-in----- 24F	326		VACUUM BOOSTER AND FUEL PUMP--- *		340
GLASS EQUIPMENT, BODY: Tinted----- *	399		WHEELS: (20 x 6.5) for 8.25 x 20 tires,		
GOVERNOR: Range 2300-3200 RPM,			5 Wheels (For fleet users only)----- 25R		291
Heavy Duty Engine, 2400-3400 RPM----- *	241		7 Wheels ----- 10F, 25R		291
MIRROR, REAR VIEW: Long, LH----- *	210		WINDSHIELD WIPERS: Dual, Electric --- *		320

\*-Weight is less than 10 pounds

10-29-54

**CHEVROLET 1955 SPECIFICATIONS—TRUCK**

**MODELS 6408 (S), 6409 (S), DATA-123**



**CHASSIS AND BODY DIMENSIONS**

Model 6502 (6502S) Flat Face Cowl Chassis  
 Model 6512 (6512S) Windshield Cowl Chassis

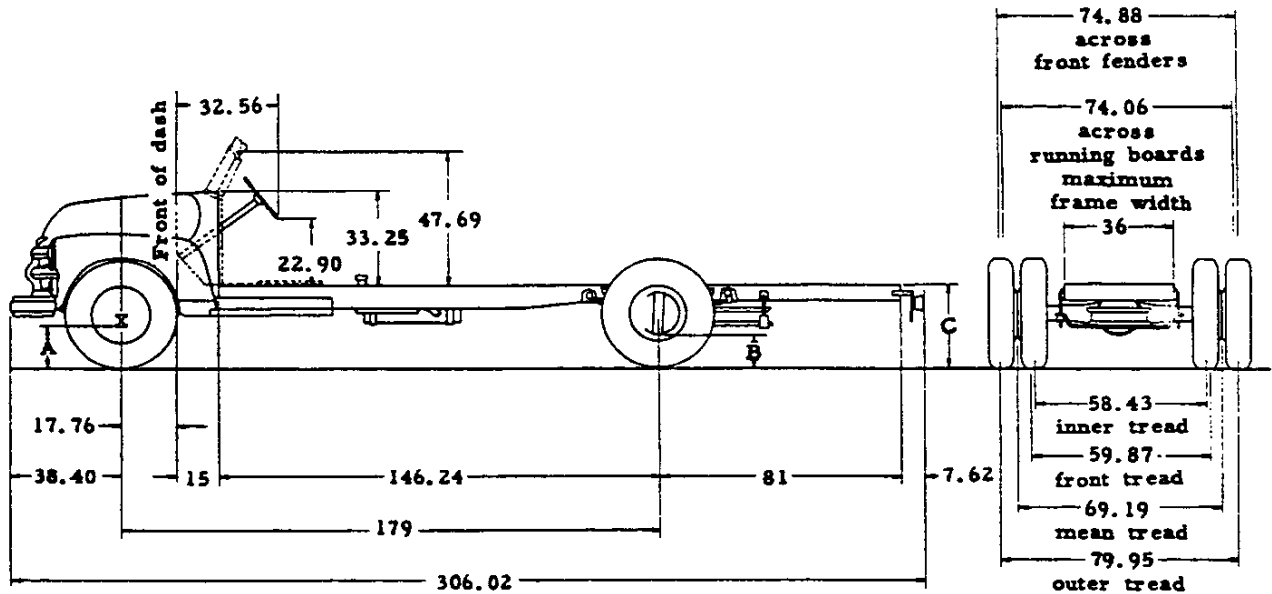

Equipment	Height Without Body and Payload		
	A	B	C
Standard	12.13	10.22	34.71
Minimum for Max GVW	12.13	10.78	35.52

To determine loaded and unloaded heights, body specifications must be known.  
 Minimum tire equipment for max GVW is 7.50-20-8pr front and 8.25-20-10 dual rr.

**VEHICLE WEIGHTS AND LOAD DISTRIBUTION**

MODEL	WITH STANDARD EQUIPMENT						WITH MINIMUM EQUIPMENT FOR MAXIMUM GVW			
	Shipping			Curb			Body and Payload	Payload Distribution		Body Length
	Front	Rear	Total	Front	Rear	Total		Front	Rear	
6502(S)	2240	2065	4305	2305	2210	4515	11450	Determined by style, length and weight of body.		
6512(S)⊕	2300	2070	4370	2365	2215	4580	11350			

⊕-Estimated weight

10-29-54

124 - MODELS 6502 (6502S), 6512 (6512S) DATA

CHEVROLET 1955 SPECIFICATIONS—TRUCK

**MODEL 6502 (6502S) HEAVY DUTY FLAT FACE COWL CHASSIS  
MODEL 6512 (6512S) HEAVY DUTY WINDSHIELD COWL CHASSIS**

2 TON (1-1/2 Ton Special) NOMINAL RATING -- 179 WHEELBASE -- 16000 lb (Special, 15000 lb) MAXIMUM GVW

**STANDARD EQUIPMENT**

<p>AIR CLEANER-AC make; oil bath type; 1 qt capacity          AXLE, FRONT----- I-beam type; 4500 lb capacity          AXLE, REAR-- Full-floating type; 13000 lb capacity;                            Hypoid gears; 6.17 ratio          BATTERY -----15 plate; 100 amp hr capacity;  <b>BRAKES</b>            PARKING--Hand-operated on prop shaft; 35 sq. in.            SERVICE ----- Hydraulic type; 4-wheel;375 sq. in.              FRONT ----- 14 x 2-1/2; 134 sq. in. area              REAR----- 15 x 4; 241 sq. in. area            BOOSTER (hydraulic) ----- Long stroke; 7 dia;            vacuum-operated          BUMPER, FRONT ----- Rigid, channel-type; painted          CLUTCH--Diaphragm spring; single disc type; 11 dia;                    123.7 sq. in. area; 282 ft lb capacity          COLOR, BASIC VEHICLE ----- Juniper Green          COOLING SYSTEM ----- Cellular radiator core; 4 lb            press. cap; 407 sq. in. frontal            area; 18 quart capacity          DISPATCH BOX ----- 6502 - 13-7/8 x 4-3/4 x 8-1/4;            6512 - 13-1/2 x 5-1/2 x 8-1/2  <b>DRIVE SYSTEM</b> ----- Hotchkiss          PROPELLER SHAFTS ----- Three          PROPELLER SHAFT BRG SUPPORTS ----- Two          UNIVERSAL JOINTS ----- Four          ENGINE ----- Loadmaster; 235.5 cu. in. displ          GROSS HP ----- 112 @ 3700 RPM          GROSS TORQUE ----- 200 ft lb @ 2000 RPM          FENDERS ----- Front only</p>	<p><b>FRAME</b>----- Ladder type with 7 cross members;                            channel side rails, 8-7/8 x 2-7/8 x 1/4;                            section modulus, 8.80 in.<sup>3</sup>  <b>FUEL TANK</b> ----- Outside of frame on right side;            18 gallon capacity  <b>GENERATOR</b> ----- 45 amp maximum rate  <b>LIGHTS</b> -----2 head, 2 parking, and 1 tail and stop  <b>RUNNING BOARDS</b> ----- Short  <b>SEAT RISER</b>----- 6512 only  <b>SPARE WHEEL CARRIER</b> ----- Underslung at rear  <b>SPRINGS</b> ----- Semi-elliptic            FRONT -- 9-leaf, 40 x 2; 2200 lb (ea)cap. at ground            REAR -----7800 lb (ea)cap. at ground              MAIN ----- 11-leaf, 46 x 2-1/2              AUXILIARY ----- 6-leaf, 31 x 2-1/2  <b>STEERING GEAR</b> ----- Recirculating-ball type; 27.76            ratio; 18-inch dia wheel  <b>TIRES</b> ----- Front and dual rear; 7.50-20-8pr;            2375 lb (ea) capacity  <b>TOOLS</b> ----- 8250 lb capacity jack; tire changing iron;            wheel wrench  <b>TOOL BOX (6512 only)</b> ----- 50 x 19 x 2-3/8  <b>TRANSMISSION</b>-- 4-speed synchro-mesh; shift lever            on transmission; provision for            power take-off on left side  <b>VENTILATOR</b> ----- Top of cowl  <b>WHEELS</b> ----- 7; wide-base rim; 20 x 6.0  <b>WINDSHIELD WIPERS</b>            (6512 only) ----- Dual; cowl mounted</p>
--	--

**OPTIONAL EQUIPMENT**

For model application see Option Section

	Wt	Number		Wt	Number
AXLE, 2-SPEED REAR: Full-floating; 13000 lb capacity; hypoid primary gears.			PLATE, IDENTIFICATION:		
6.13 and 8.10 ratios -----105R	202		1-1/2 Ton Special ----- *		402
6.70 and 8.86 ratios -----105R	201		SHOCK ABSORBERS, FRONT:		
COLORS, VEHICLE: Solid ----- *	234		Direct double-acting type;		
CRANKCASE VENTILATION: Vac-operated with filtered air from oil bath air cleaner *	217		1-3/8 dia piston ----- 16F	200	
ENGINE, HEAVY DUTY:			SPRINGS, REAR:		
Jobmaster. 261 cu. in. displ			Two-stage, 11-leaf; 5600 lb (ea)		
Gross HP, 135 @ 4000 RPM			capacity at ground ----- Minus 75R	268	
Gross Torque, 220 ft lb @ 2000 RPM-- *	225		TANK, VACUUM RESERVE:		
GENERATOR: Including voltage and current regulator, and pulley for high output			1000 cu. in. capacity ----- 6F, 6R	281	
40 amp ----- *	326		TIRES, MAXIMUM: (RPO 291 mandatory)		
50 amp ----- *	326		Front, 8.25-20-10pr; 2900 lb (ea)		
55 amp ----- 27F	326		capacity ----- 40F	343	
55 amp, low cut-in ----- 24F	326		Dual Rear, 9.00-20-10pr; 3450 lb (ea)		
GOVERNOR: Range 2300-3200 RPM;			capacity ----- 150R	312	
Heavy Duty Engine, 2400-3400 RPM--- *	241		VACUUM BOOSTER AND FUEL PUMP --- *	340	
OIL FILTER: AC make,			WHEELS: (20 x 6.5)		
1 quart capacity ----- 8F	237		For 8.25 or 9.00 x 20 tires,		
2 quart capacity ----- 15F	237		5 Wheels (For fleet users only) ----- 25R	291	
			7 Wheels ----- 10F, 25R	291	
			WINDSHIELD WIPERS: (6512 only)		
			Dual, Electric ----- *	320	

\*-Weight is less than 10 pounds

10-29-54

**CHEVROLET 1955 SPECIFICATIONS--TRUCK**

**MODELS 6502 (6502S), 6512 (6512S) DATA - 125**

CHASSIS AND BODY DIMENSIONS

Model 6503 (6503S) Cab Chassis

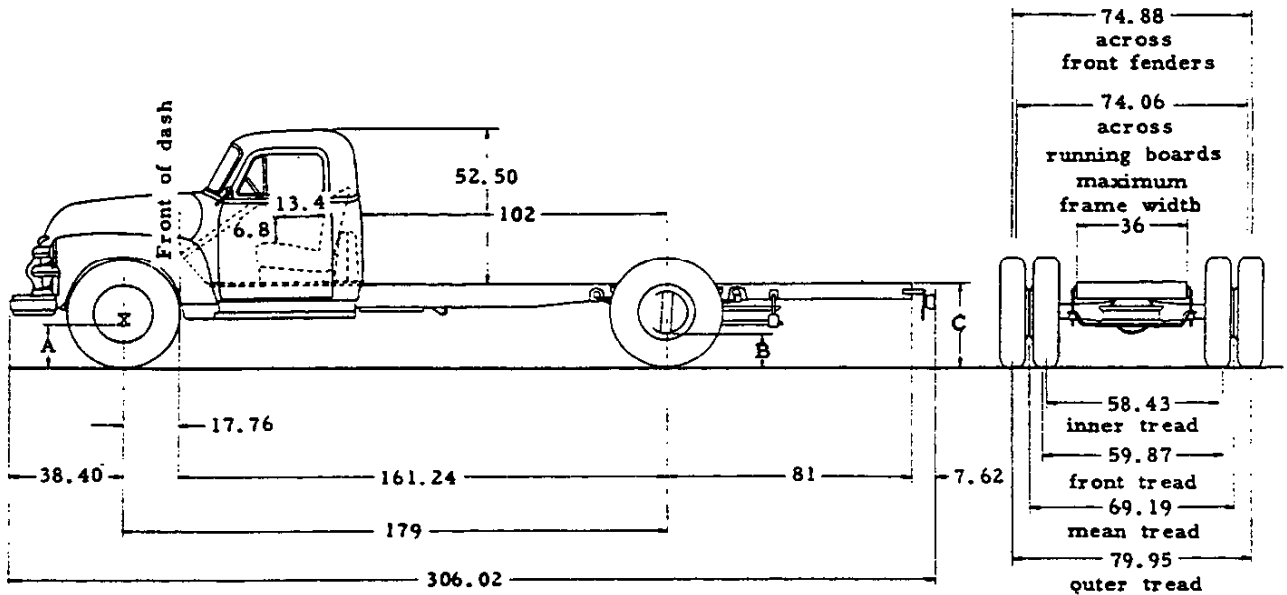

Seat in rear position  
adjustment 3.38

Equipment	Height Without Body and Payload		
	A	B	C
Standard	12.07	10.22	34.75
Minimum for Max GVW	12.07	10.78	35.57

To determine loaded and unloaded heights, body specifications must be known. Minimum tire equipment for max GVW is 7.50-20-8pr front and 8.25-20-10 dual rr.

VEHICLE WEIGHTS AND LOAD DISTRIBUTION

MODEL	WITH STANDARD EQUIPMENT						WITH MINIMUM EQUIPMENT FOR MAXIMUM GVW			
	Shipping			Curb			Body and Payload	Payload Distribution		Body Length
	Front	Rear	Total	Front	Rear	Total		Front	Rear	
6503 (S)	2555	2200	4755	2655	2310	4965	11000	9%	91%	168
								6%	94%	180
								2%	98%	192

10-29-54

126 - MODEL 6503 (6503S) DATA -

CHEVROLET 1955 SPECIFICATIONS—TRUCK

## MODEL 6503 (6503S) HEAVY DUTY CAB CHASSIS

2 TON (1-1/2 Ton Special) NOMINAL RATING -- 179 WHEELBASE -- 16000 lb (Special, 15000 lb) MAXIMUM GVW

STANDARD EQUIPMENT	EQUIPMENT
AIR CLEANER ---AC make; oil bath type; 1 qt capacity	FRAME -----Ladder type with 7 cross members, channel side rails, 8-7/8 x 2-7/8 x 1/4; section modulus 8.80 in. <sup>3</sup>
AXLE, FRONT ----- 1-beam type; 4500 lb capacity	FUEL TANK -- Back of seat in cab; 17-1/2 gal cap.
AXLE, REAR --- Full-floating type; 13000 lb capacity; Hypoid gears; 6.17 ratio	GENERATOR ----- 45 amp maximum rate
BATTERY ----- 15 plate; 100 amp hr capacity;	LIGHTS -----2 head, 2 parking, and 1 tail and stop
BRAKES	MIRROR, REAR ----- LH; long adjustable bracket
PARKING--Hand-operated; on prop shaft; 35 sq. in.	RUNNING BOARDS ----- Short
SERVICE ---- Hydraulic type; 4-wheel; 375 sq. in.	SEAT ----- Full Width
FRONT ----- 14 x 2-1/2; 134 sq. in. area	SPARE WHEEL CARRIER-----Underslung at rear
REAR ----- 15 x 4; 241 sq. in. area	SPRINGS
BOOSTER (hydraulic)----- Long stroke; 7 dia; vacuum-operated	FRONT ----- Semi-elliptic; 9-leaf, 40 x 2; 2200 lb (ea) capacity at ground
BUMPER, FRONT ----- Rigid, channel-type; painted	REAR ---- Semi-elliptic; 7800 lb (ea) cap. at ground
CAB ----- All-steel; welded; flexibly mounted	MAIN ----- 11-leaf, 46 x 2-1/2
CLUTCH--Diaphragm spring; single disc type; 11 dia; 123.7 sq. in. area; 282 ft lb capacity	AUXILIARY----- 6-leaf, 31 x 2-1/2
COLOR, BASIC VEHICLE ----- Juniper Green	STEERING GEAR----- Recirculating-ball type; 27.76 ratio; 18-inch dia wheel
COOLING SYSTEM ---- Cellular radiator core, 4 lb press. cap; 407 sq. in. frontal area; 18 quart capacity	SUNSHADE ----- Adjustable; for driver
DISPATCH BOX ----- 13-1/2 x 5-1/2 x 8-1/2	TIRES ----- Front and dual rear; 7.50-20-8pr; 2375 lb (ea) capacity
DOME LIGHT ----- Above rear window	TOOLS ----- 8250 lb cap. jack; tire iron; wheel wrench
DRIVE SYSTEM ----- Hotchkiss	TOOL BOX ----- Under seat; 50 x 19 x 6
PROPELLER SHAFTS ----- Three	TRANSMISSION -- 4-speed, synchro-mesh; shift lever on transmission; provision for power take-off on left side
PROPELLER SHAFT BRG SUPPORTS----- Two	VENTILATORS ----- Top of cowl and ventipanes
UNIVERSAL JOINTS ----- Four	WHEELS ----- 7; wide-base rim; 20 x 6.0
ENGINE ----- Loadmaster; 235.5 cu. in. displ	WINDSHIELD
GROSS HP ----- 112 @ 3700 RPM	WIPERS ----- Dual; cowl mounted
GROSS TORQUE ----- 200 ft lb @ 2000 RPM	
FENDERS ----- Front only	

### OPTIONAL EQUIPMENT

For model application see Option Section

	Wt	Number		Wt	Number
AXLE, 2-SPEED REAR: Full-floating; 13000 lb capacity; hypoid primary gears.			OIL FILTER: AC make;		
6.13 and 8.10 ratios ----- 105R	202		1 quart capacity -----	8F	237
6.70 and 8.86 ratios ----- 105R	201		2 quart capacity -----	15F	237
COLORS, VEHICLE: Solid ----- *	234		PLATE, IDENTIFICATION:		
CORNER WINDOWS, CAB ----- *	387		1-1/2 Ton Special ----- *		402
CRANKCASE VENTILATION: Vac-operated with filtered air from oil bath air cleaner----- *	217		SEAT EQUIPMENT: Unison ----- *		264
ENGINE, HEAVY DUTY:			SHOCK ABSORBERS, FRONT:		
Jobmaster, 261 cu. in. displ			Direct double-acting type, 1-3/8 dia piston -----	16F	200
Gross Hp. 135 @ 4000 RPM			SIDE DOOR KEY LOCK, LH----- *		395
Gross Torque, 220 ft lb @ 2000 RPM----- *	225		SPRINGS, REAR:		
GENERATOR: Including voltage and current regulator, and pulley for high output			Two-stage, 11-leaf; 5600 lb (ea) capacity at ground -----	Minus 75R	268
40 amp ----- *	326		TANK, VACUUM RESERVE		
50 amp ----- *	326		1000 cu. in. capacity -----	6F, 6R	281
55 amp ----- *	27F		TIRES, MAXIMUM: (RPO 291 mandatory)		
55 amp, low cut-in. ----- *	24F		Front, 8.25-20-10pr; 2900 lb (ea) capacity -----	40F	343
GLASS EQUIPMENT, BODY:			Dual Rear, 9.00-20-10pr; 3450 lb (ea) capacity -----	150R	312
Tinted ----- *	399		VACUUM BOOSTER AND FUEL PUMP----- *		340
GOVERNOR: Range 2300-3200 RPM:			WHEELS: (20 x 6.5) For 8.25 or 9.00 x 20 tires		
Heavy Duty Engine, 2400-3400 ----- *	241		5 Wheels (For fleet users only) -----	25R	291
MIRROR, REAR VIEW:			7 Wheels -----	10F, 25R	291
Short, RH or LH ----- *	210		WINDSHIELD WIPERS: Dual, Electric----- *		320
Long, RH ----- *	210				

\*--Weight is less than 10 pounds

10-29-54

CHEVROLET 1955 SPECIFICATIONS--TRUCK

MODEL 6503 (6503S) DATA -127

CHASSIS AND BODY DIMENSIONS

Model 6702 School Bus Flat Face Cowl Chassis

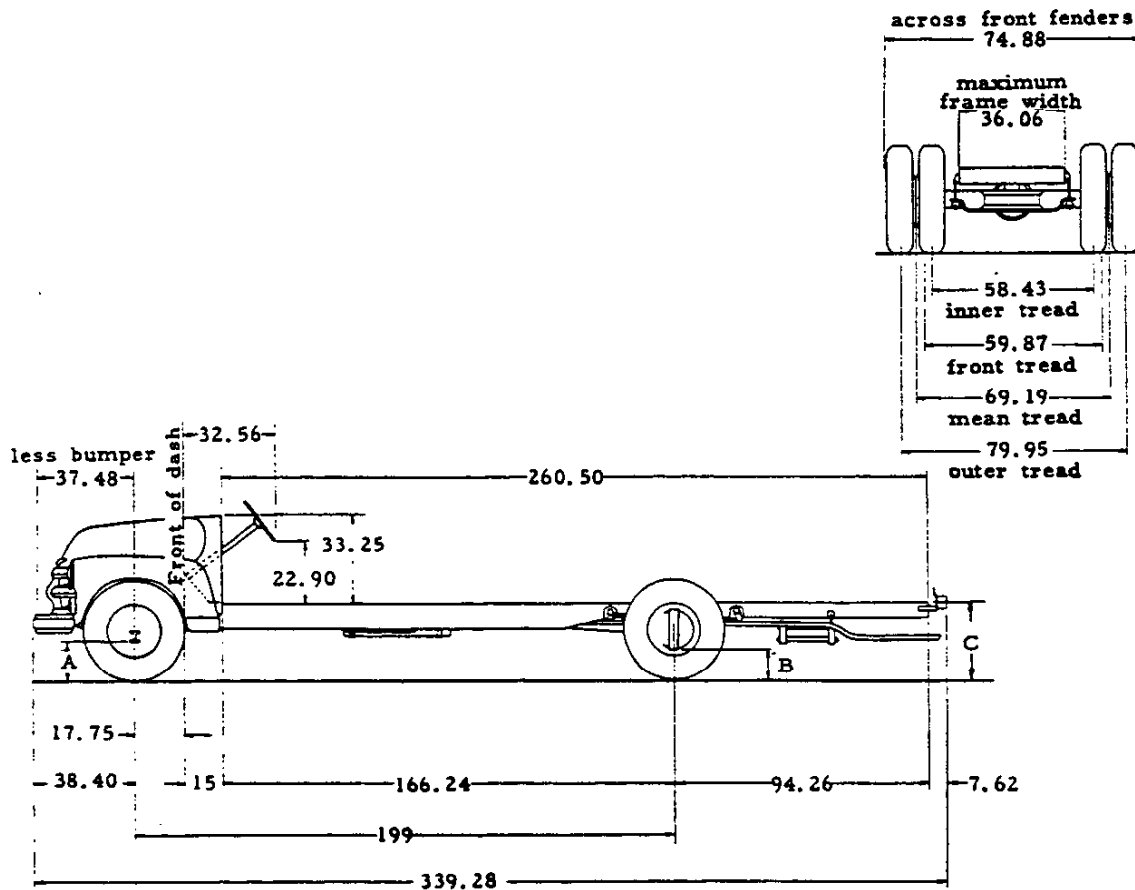

Equipment	Height Without Body and Payload		
	A	B	C
Standard	12.13	10.22	37.41
Minimum for Max GVW	12.13	10.78	38.03

To determine loaded and unloaded heights, body specifications must be known. Minimum tire equipment for max GVW is 7.50-20-8pr front and 8.25-20-10pr dual rr.

VEHICLE WEIGHTS AND LOAD DISTRIBUTION

MODEL	WITH STANDARD EQUIPMENT						WITH MINIMUM EQUIPMENT FOR MAXIMUM GVW			
	Shipping			Curb			Body and Payload	Payload Distribution		Body Length
	Front	Rear	Total	Front	Rear	Total		Front	Rear	
6702	2320	2120	4440	2430	2295	4725	11200	Determined by style, length and weight of body.		

10-29-54

128-MODEL 6702 DATA

CHEVROLET 1955 SPECIFICATIONS—TRUCK

**MODEL 6702 HEAVY DUTY SCHOOL BUS FLAT FACE COWL CHASSIS**  
**2 TON NOMINAL RATING --- 199 WHEELBASE --- 16000 lb MAXIMUM GVW**

**STANDARD EQUIPMENT**

AIR CLEANER -- AC make; oil bath type; 1 qt capacity  
 AXLE, FRONT ----- I-beam type; 4500 lb capacity  
 AXLE, REAR---Full-floating type; 13000 lb capacity;  
                     Hypoid gears; 6.17 ratio  
 BATTERY ----- 19 plate; 125 amp hr capacity  
**BRAKES**  
     PARKING--Hand-operated on prop shaft; 35 sq. in.  
     SERVICE ---- Hydraulic type; 4-wheel; 375 sq. in.  
         FRONT-----14 x 2-1/2; 134 sq. in. area  
         REAR-----15 x 4; 241 sq. in. area  
     BOOSTER (hydraulic) ----- Long stroke; 7 dia;  
   vacuum-operated  
 BUMPER, FRONT ----- Rigid, channel-type; painted  
 CLUTCH--Diaphragm spring; single disc type; 11 dia;  
             123.7 sq. in. area; 282 ft lb capacity  
 COLOR, BASIC VEHICLE ----- Juniper Green  
 COOLING SYSTEM ---- Cellular radiator core; 4 lb  
                             press. cap; 407 sq. in. frontal  
                             area; 18 quart capacity  
 DISPATCH BOX ----- 13-7/8 x 4-3/4 x 8-1/4  
 DRIVE SYSTEM ----- Hotchkiss  
 PROPELLER SHAFTS ----- Three  
 PROPELLER SHAFT BRG SUPPORTS ----- Two  
 UNIVERSAL JOINTS ----- Four  
 ENGINE ----- Loadmaster; 235.5 cu. in. displ  
 GROSS HP ----- 112 @ 3700 RPM  
 GROSS TORQUE ----- 200 ft lb @ 2000 RPM

FENDERS ----- Front only  
 FRAME ---- Ladder type with 9 cross members,  
             channel side rails, 8-15/16x2-29/32x9/32;  
             section modulus 9.94 in<sup>3</sup>  
 FUEL LINE, FLEXIBLE ----- Engine end  
 FUEL TANK ----- Outside of frame on right side;  
                             30 gallon capacity  
 GENERATOR ----- 45 amp maximum rate  
 GOVERNOR ----- Set at 35 MPH  
 LIGHTS ----- 2 head, 2 parking, and 1 tail and stop  
 PROPELLER SHAFT GUARDS ----- Three  
 SPARE WHEEL CARRIER ----- Underslung at rear  
 SPRINGS ----- Semi-elliptic  
         FRONT--- 9-leaf, 40 x 2; 2200 lb (ea) cap. at ground  
         REAR----- Two-stage; 11-leaf, 46 x 2-1/2; 5600  
                             lb (ea) capacity at ground  
 STEERING GEAR ----- Recirculating-ball type; 27.76  
                             ratio; 18-inch dia wheel  
 TIRES ----- Front and dual rear; 7.50-20-8pr;  
                             2375 lb (ea) capacity  
 TOOLS ----- 8250 lb capacity jack; tire changing iron;  
                             wheel wrench  
 TRANSMISSION -- 4-speed, synchro-mesh; shift lever  
                             on transmission; provision for  
                             power take-off on left side  
 VENTILATOR ----- Top of cowl  
 WHEELS ----- 7; wide-base rim; 20 x 6.0

**OPTIONAL EQUIPMENT**

For model application see Option Section

	Wt	Number		Wt	Number
AXLE, 2-SPEED REAR: Full-floating, 13000 lb capacity; hypoid primary gears.			OIL FILTER: AC make		
6.13 and 8.10 ratios ----- 106R	202		1 quart capacity ----- 8F	237	
6.70 and 8.86 ratios ----- 106R	201		2 quart capacity ----- 15F	237	
COLORS, VEHICLE: Solid ----- *	234		SHOCK ABSORBERS: Direct double-acting,		
CRANKCASE VENTILATION: Vac-operated with filtered air from oil bath air cleaner---- *	217		Front, 1-3/8 dia piston ----- 16F	200	
ENGINE, HEAVY DUTY:			Rear, 1-3/8 dia piston ----- 24R	200	
Jobmaster, 261 cu. in. displ			SPRINGS, FRONT: 9-leaf with double-wrap eye at fixed end ----- *	255	
Gross HP, 135 @ 4000 RPM			TANK, VACUUM RESERVE:		
Gross Torque, 220 ft lb @ 2000 RPM --- *	225		1000 cu. in. capacity ----- 6F, 6R	281	
GENERATOR: With voltage and current regulator, and pulley for high output			TIRES, MAXIMUM: (RPO 291 mandatory)		
40 amp ----- *	326		Front and Dual Rear, 8.25-20-12pr;		
50 amp ----- *	326		3150 lb (ea) capacity ----- 56F, 116R	344	
55 amp ----- 27F	326		VACUUM BOOSTER AND FUEL PUMP --- *	340	
55 amp, low cut-in ----- 24F	326		WHEELS: (20 x 6.5) For 8.25 x 20 tires;		
			5 Wheels (For fleet users only) ----- 25R	291	
			7 Wheels ----- 10F, 25R	291	

\* - Weight is less than 10 pounds

10-29-54

CHASSIS AND BODY DIMENSIONS

Model 6802 School Bus Flat Face Cowl Chassis

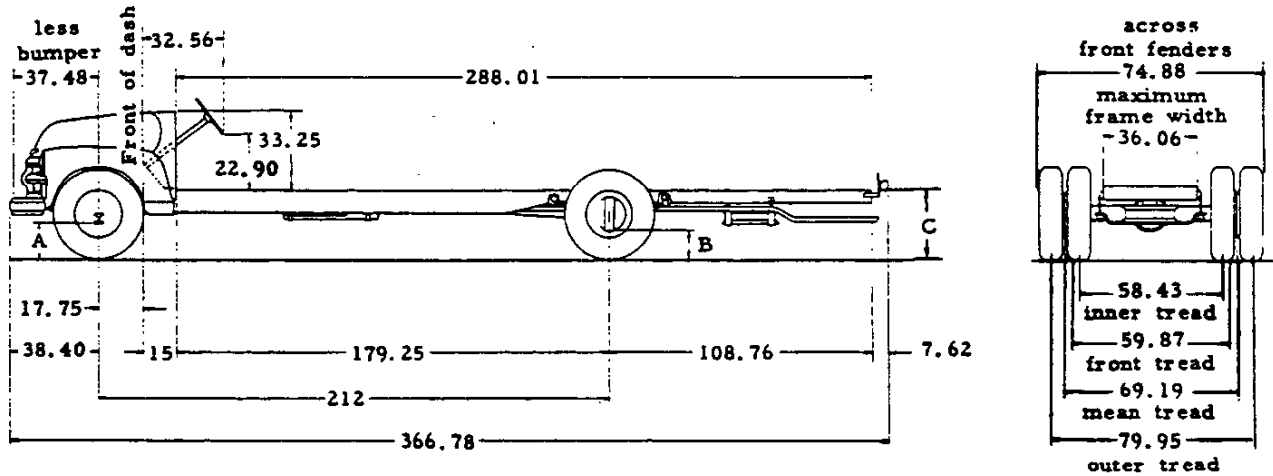

Equipment	Height Without Body and Payload		
	A	B	C
Standard	12.06	10.18	37.52
Minimum for Max GVW	12.13	10.77	38.46

To determine loaded and unloaded heights, body specifications must be known. Minimum tire equipment for max GVW is 7.50-20-8pr front and 8.25-20-10 dual rr.

VEHICLE WEIGHTS AND LOAD DISTRIBUTION

MODEL	WITH STANDARD EQUIPMENT						WITH MINIMUM EQUIPMENT FOR MAXIMUM GVW			
	Shipping			Curb			Body and Payload	Payload Distribution		Body Length
	Front	Rear	Total	Front	Rear	Total		Front	Rear	
68020	2305	2140	4445	2420	2310	4730	11200	Determined by style, length and weight at body.		

10-29-54

130-MODEL 6802 DATA

● - Estimated weight

CHEVROLET 1955 SPECIFICATIONS—TRUCK

## MODEL 6802 HEAVY DUTY SCHOOL BUS FLAT FACE COWL CHASSIS

2 TON NOMINAL RATING --- 212 WHEELBASE --- 16000 lb MAXIMUM GVW

STANDARD EQUIPMENT	STANDARD EQUIPMENT
AIR CLEANER -- AC make; oil bath type; 1 qt capacity	FENDERS ----- Front only
AXLE, FRONT ----- 1-beam type; 4500 lb capacity	FRAME--- Ladder type with 9 cross members,
AXLE, REAR -- Full-floating type; 13000 lb capacity;	channel side rails 8-15/16 x 2-29/32 x 9/32;
Hypoid gears; 6.17 ratio	section modulus 9.94 in. <sup>3</sup>
BATTERY ----- 19 plate; 125 amp hr capacity	FUEL LINE, FLEXIBLE ----- Engine end
BRAKES	FUEL TANK ----- Outside of frame on right side;
PARKING -- Hand-operated on prop shaft; 35 sq. in.	30 gallon capacity
SERVICE ---- Hydraulic type; 4-wheel; 375 sq. in.	GENERATOR ----- 45 amp maximum rate
FRONT ----- 14 x 2-1/2; 134 sq. in. area	GOVERNOR ----- Set at 35 MPH
REAR ----- 15 x 4; 241 sq. in. area	LIGHTS ----- 2 head, 2 parking, and 1 tail and stop
BOOSTER (hydraulic) ----- Long stroke; 7 dia;	PROPELLER SHAFT GUARDS ----- Three
vacuum-operated	SPARE WHEEL CARRIER ----- Underslung at rear
BUMPER, FRONT ----- Rigid, channel type; painted	SPRINGS ----- Semi-elliptic
CLUTCH--Diaphragm spring; single disc type; 11 dia;	FRONT ---9-leaf, 40 x 2; 2200 lb (ea) cap. at ground
123.7 sq. in. area; 282 ft lb capacity	REAR ----- Two-stage; 11-leaf, 46 x 2-1/2; 5600
COLOR, BASIC VEHICLE ----- Juniper Green	lb (ea) capacity at ground
COOLING SYSTEM----- Cellular radiator core; 4 lb	STEERING GEAR ----- Recirculating-ball type: 27.76
press. cap. 407 sq. in. frontal	ratio; 18-inch dia wheel
area; 18 quart capacity	TIRES ----- Front and dual rear; 7.50-20-8pr;
DISPATCH BOX ----- 13-7/8 x 4-3/4 x 8-1/4	2375 lb (ea) capacity
DRIVE SYSTEM----- Hotchkiss	TOOLS ----- 8250 lb capacity jack; tire changing iron;
PROPELLER SHAFTS ----- Three	wheel wrench
PROPELLER SHAFT BRG SUPPORTS ----- Two	TRANSMISSION -- 4-speed, synchro-mesh; shift lever
UNIVERSAL JOINTS ----- Four	on transmission; provision for
ENGINE ----- Loadmaster; 235.5 cu. in. displ	power take-off on left side
GROSS HP ----- 112 @ 3700 RPM	VENTILATOR ----- Top of cowl
GROSS TORQUE ----- 200 ft lb @ 2000 RPM	WHEELS ----- 7; wide-base rim; 20 x 6.0

### OPTIONAL EQUIPMENT

For model application see Option Section

	Wt	Number		Wt	Number
AXLE, 2-SPEED REAR: Full-floating; 13000 lb			OIL FILTER: AC make,		
capacity; hypoid primary gears.			1 quart capacity -----	8F	237
6.13 and 8.10 ratios -----	106R	202	2 quart capacity -----	15F	237
6.70 and 8.86 ratios -----	106R	201	SHOCK ABSORBERS: Direct double-acting		
COLORS, VEHICLE: Solid -----*		234	Front, 1-3/8 dia piston -----	-16F	200
CRANKCASE VENTILATION: Vac-operated with			Rear, 1-3/8 dia piston -----	24R	200
filtered air from oil bath air cleaner --- *		217	SPRINGS, FRONT: 9-leaf with double-wrap		
ENGINE, HEAVY DUTY:			eye at fixed end-----	*	255
Jobmaster, 261 cu. in. displ			TANK, VACUUM RESERVE:		
Gross HP, 135 @ 4000 RPM			1000 cu. in. capacity -----	6F, 6R	281
Gross Torque, 220 ft lb @ 4000 RPM ---- *		225	TIRES, MAXIMUM: (RPO 291 mandatory)		
GENERATOR: With voltage and current			Front and Dual Rear; 8.25-20-12pr;		
regulator, and pulley for high output:			3150 lb (ea) capacity-----	56F, 116R	344
40 amp -----	326		VACUUM BOOSTER AND FUEL PUMP-----*		340
50 amp -----	326		WHEELS: (20 x 6.5) For 8.25 x 20 tires,		
55 amp -----	27F	326	5 Wheels (For fleet users only)-----	25R	291
55 amp, low cut-in -----	24F	326	7 Wheels-----	-10F, 25R	291

\* - Weight is less than 10 pounds

10-29-54

CHEVROLET 1955 SPECIFICATIONS—TRUCK

MODEL 6802 DATA-131



### CHASSIS TREADS AND OVERALL WIDTHS

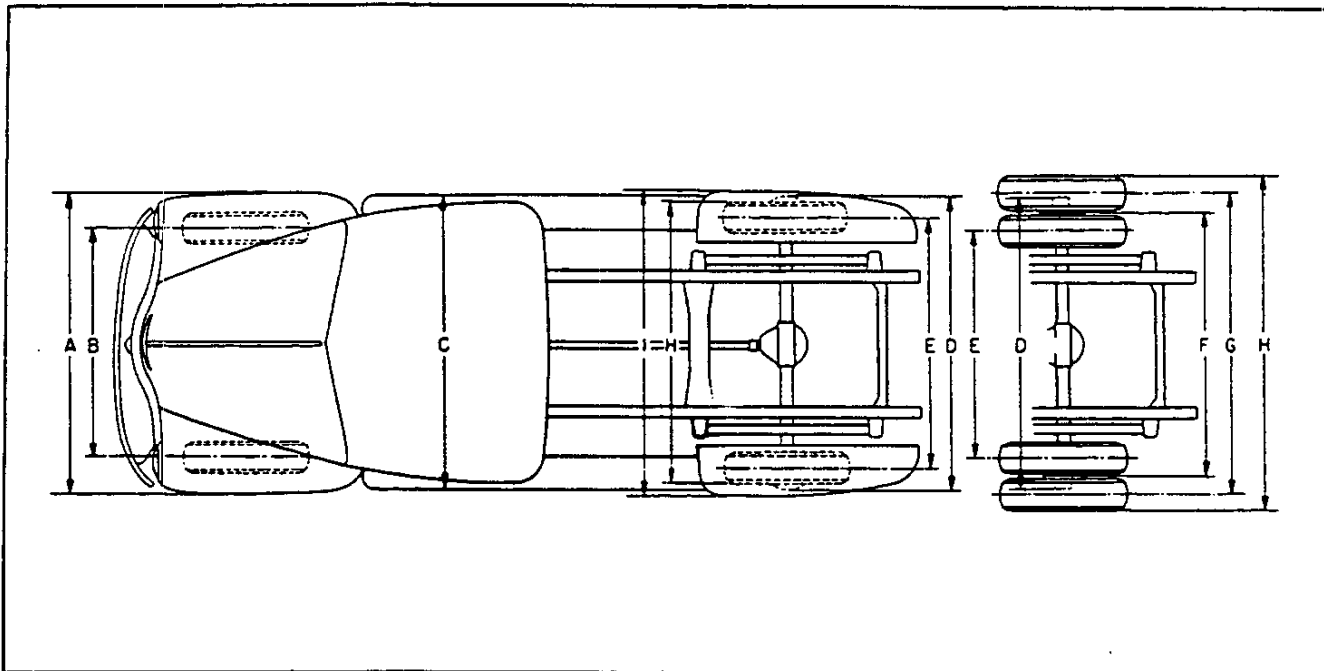

Tires	Models	A Across Front Fenders	B Front Wheel Tread	C Across Running Boards	D Over Rear Hubs or Hub Caps	E Inner Wheel Tread	F Dual Mean Tread	G Outer Wheel Tread	H Over Rear Tires	I Over Rear Fenders
6.00-16	3100	72.62	57.03	72.94	69.81	61.02			67.44	-74.53
6.50-16			58.13						67.82	
15-6pr			57.21						69.80	
7.00-17	3600	72.62	56.52	72.94	72.12	61.77			70.07	
7.50-17			56.52						69.35	
6.50-16			57.00						69.78	
15-6pr	3700	72.62	62.08	72.94	72.12	61.79			80.37	
7.00-17			61.41						70.04	
7.50-17			61.41						69.35	
7.00-17	3800	72.62	56.53	72.94	72.12	61.79			69.80	75.25, 3805-07; 74.50, 3804
7.50-17			56.53						69.37	
7.00-18	3802-03-08-09-12	72.62	56.91	72.94	71	54.13	63.25	72.37	79.95	
7.00-17	3900	72.62	61.41	72.94	72.12	61.76			69.37	
7.50-17			61.41						69.79	
7.00-18			61.79						79.94	
6.50-20	4100	74.88	56.27	74.08	77.25	57.17	66.67	76.17	83.43	
7.00-20	4400		55.14						83.76	
7.50-20	55.14		85.49							
6.50-20	4502	74.88	61.02	74.08	77.25	57.17	66.67	76.17	83.43	
7.00-20			61.02						83.76	
7.50-20			59.72						85.99	
7.50-20	5000	77.56	61.37	77.40	79.75	58.43	69.19	79.95	88.37	
8.25-20									61.37	
7.50-20	6100	74.88	59.87	74.08	79.75	58.43	69.19	79.95	88.37	
6400	59.87								88.95	
8.25-20	6500								59.87	
7.50-20	6702	77.56	60.87	77.40	79.75	58.43	69.19	79.95	88.37	
8.25-20	6802								60.87	
8.25-20	5000	77.56	60.87	77.40	79.75	58.43	69.19	79.95	88.37	
Front	6100	74.88	59.37	74.08	79.75	57.93		80.45	90.39	
Rear	6400									
	6500	74.88	59.37	74.08	79.75	57.93		80.45	90.39	

10-29-54

### COWL DIMENSIONS

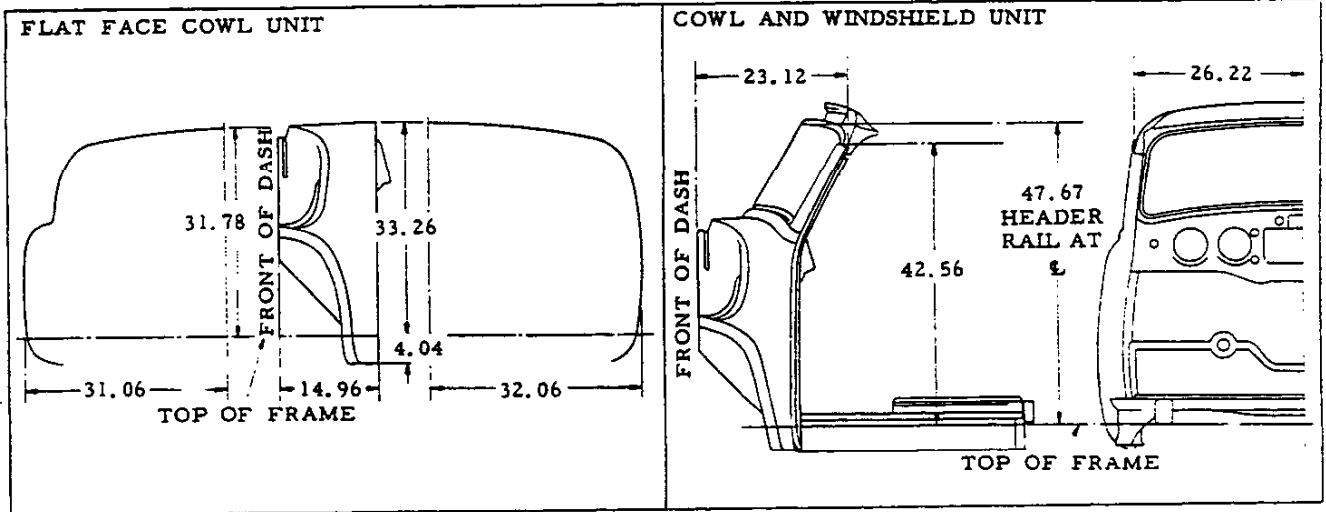

### CAB EXTERIOR DIMENSIONS

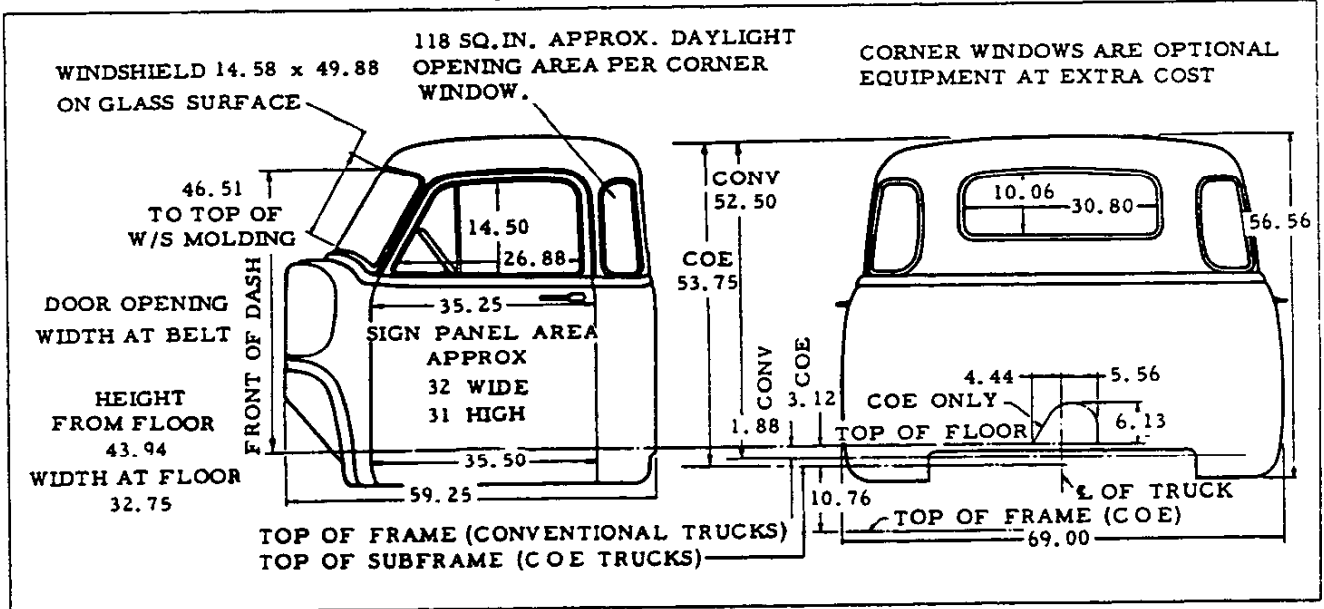

### DRIVER COMPARTMENT AND SEAT DIMENSIONS

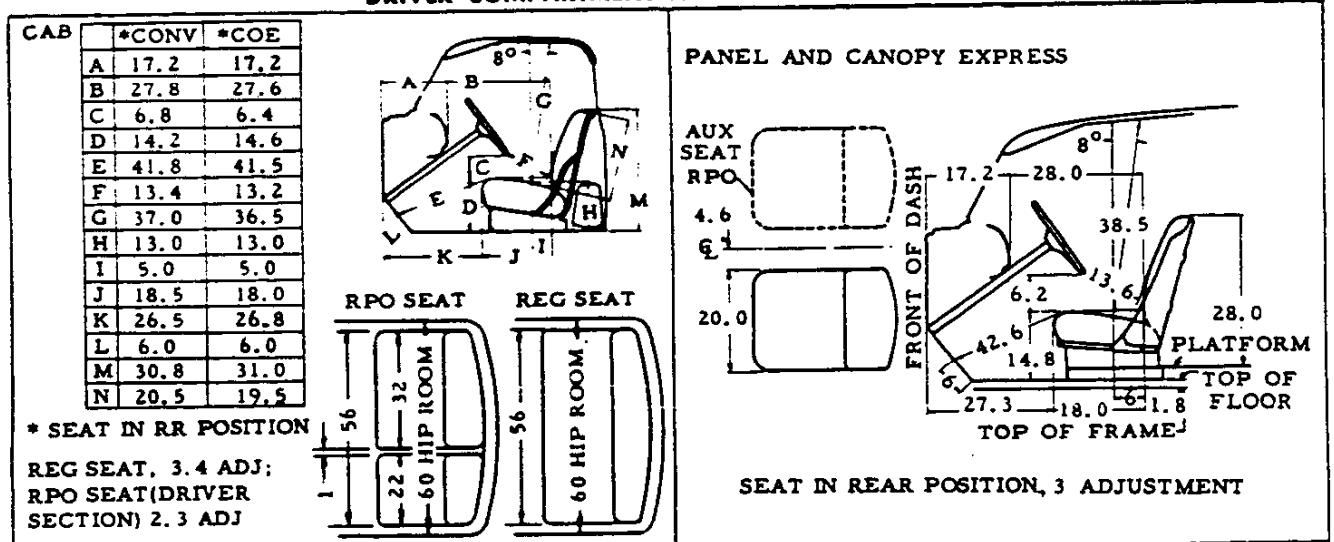

10-29-54

## EXTERIOR APPEARANCE AND COLORS

Light Duty Trucks

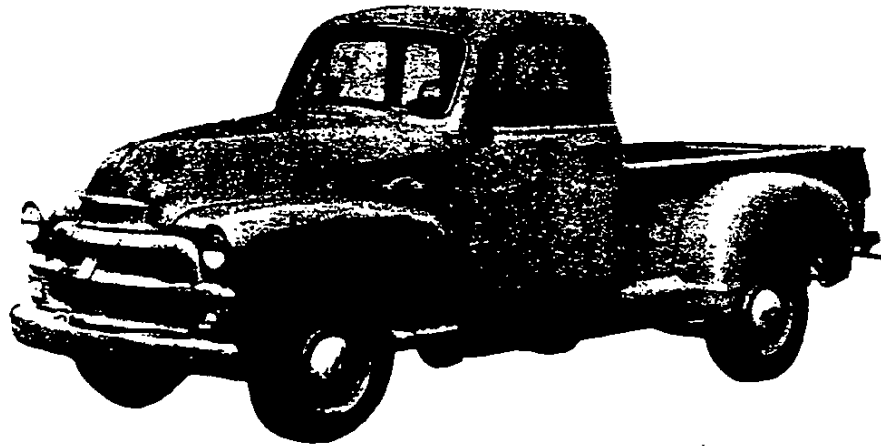

Heavy Duty Trucks

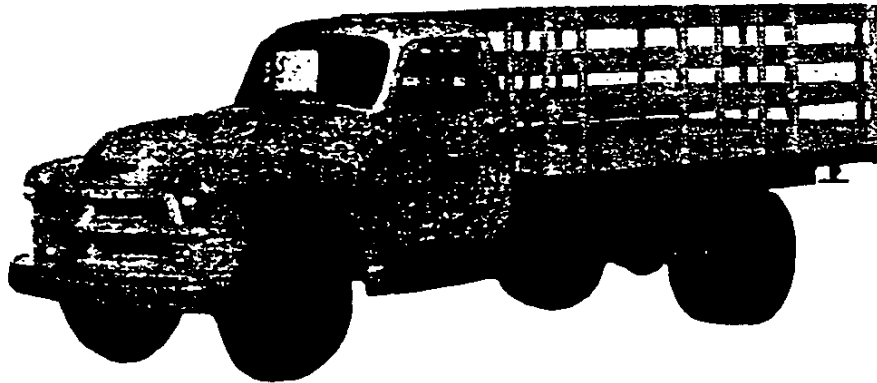

### PAINT COLOR COMBINATIONS

Regular or RPO	Basic Color (Baking Dulux)	Wheel Striping Color (Duco®)
Regular	Juniper Green	Cream Medium
RPO 234	Commercial Red	Argent Silver
438	Jet Black	Argent Silver
439	Omaha Orange	Jet Black
	Mariner Blue	Cream Medium
	Cream Medium	Jet Black
	Yukon Yellow	Jet Black
	Ocean Green	Jet Black
	Transport Blue	Cream Medium
	Coppertone	Bombay Ivory
	Autumn Brown	Bombay Ivory
	Pure White	Juniper Green

**Wheels:**

Regular Production ..... Black  
 Deluxe Solid Body Color ..... Body color  
 Deluxe Two-tone Body Color ..... Lower, body color  
 16" (3100 only) ..... Striped  
 Deluxe equipment is not specified for Canopy Express models.

#### TYPES OF PAINT

Baking Dulux ..... Baking enamel  
 Duco ..... Striping lacquer  
 Air Dry Dulux ..... Air drying enamel

10-29-54

**134 EXTERIOR APPEARANCE AND COLORS**

### HOOD AND GRILLE APPEARANCE

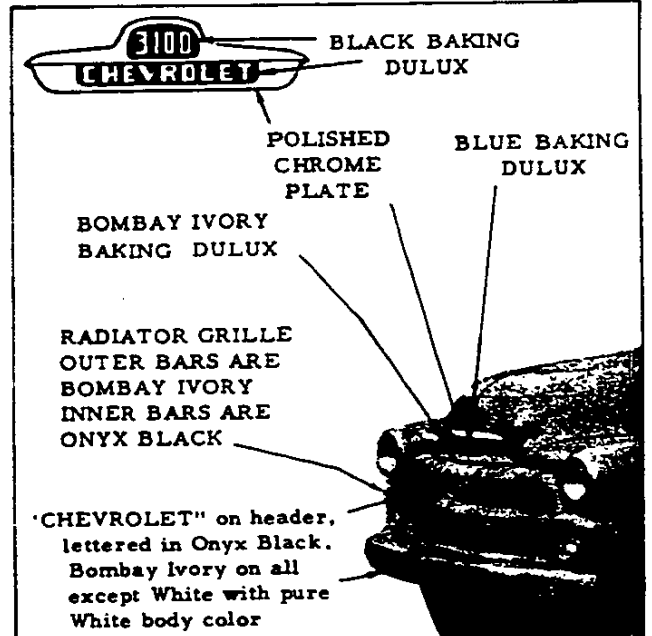

**CHEVROLET 1955 SPECIFICATIONS—TRUCK**

## FRAME

CONVENTIONAL TYPE OF FRAME

CAB-OVER-ENGINE TYPE OF FRAME

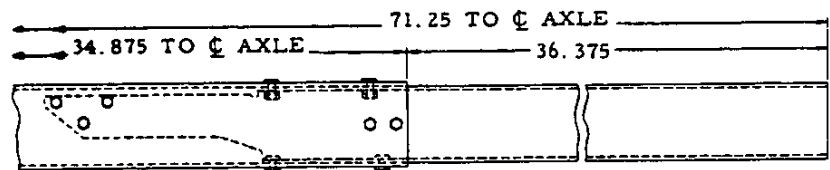
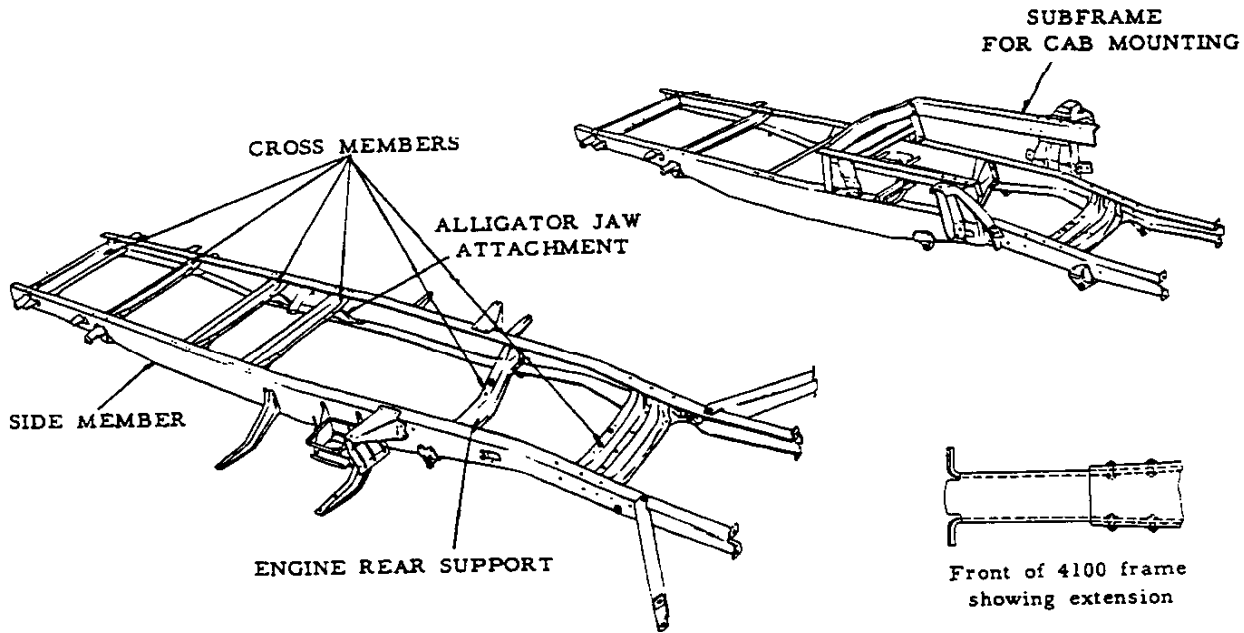

Front of 3800 frame

Front of 4100 frame showing extension

Frame rear extension on 4502

MODEL	Wheel-base	Frame Overall Length*	Width Over Side Members	Number of Cross Members	Section Modulus $\text{in}^3$	Frame type ----- Ladder Side member data: Section type ----- Channel Kickup height, at rear axle ----- -- 1.62 on 3100; 1.75 on 3600, 3700 Material ---- Hot rolled steel, pickled Yield point ----- 39000 PSI (min.) Elongation ----- 25% in two inches																										
CONVENTIONAL	3100	116	46.03 at rear	4	2.46																											
	3600	125.25	185.32	36	3.25																											
	3700		195.31																													
	3800	137	213.06		5		5.52																									
	3900		214.59																													
	4100		221.18																													
	4400	161	233.42		b		8.80																									
	6100 †	137	209.42		5																											
	6400	161	233.42		b																											
6500	179	297.48	7																													
4502	161	269.76	8																													
SCHUOL	4502	161	269.76	8	9.94																											
	6702	199	330.73	36.0b		9																										
	6802	212	358.23																													
COE	5100	110	182.42	36	5	8.80																										
	5400	134	206.42																													
	5700	158	230.42				6																									
						<table border="1"> <thead> <tr> <th rowspan="2">SERIES</th> <th colspan="3">Max Sectional Dimensions</th> </tr> <tr> <th>a</th> <th>b</th> <th>c</th> </tr> </thead> <tbody> <tr> <td>3100</td> <td>5.75</td> <td rowspan="2">2.25</td> <td>.14</td> </tr> <tr> <td>3600, 3700</td> <td>5.84</td> <td>.18</td> </tr> <tr> <td>3800, 3900, 4100</td> <td>7</td> <td>2.75</td> <td>.22</td> </tr> <tr> <td>4400, 4500, 5000, 6100, 6400, 6500</td> <td>8.88</td> <td>2.88</td> <td>.25</td> </tr> <tr> <td>6700, 6800</td> <td>8.94</td> <td>2.90</td> <td>.28</td> </tr> </tbody> </table>	SERIES	Max Sectional Dimensions			a	b	c	3100	5.75	2.25	.14	3600, 3700	5.84	.18	3800, 3900, 4100	7	2.75	.22	4400, 4500, 5000, 6100, 6400, 6500	8.88	2.88	.25	6700, 6800	8.94	2.90	.28
SERIES	Max Sectional Dimensions																															
	a	b	c																													
3100	5.75	2.25	.14																													
3600, 3700	5.84		.18																													
3800, 3900, 4100	7	2.75	.22																													
4400, 4500, 5000, 6100, 6400, 6500	8.88	2.88	.25																													
6700, 6800	8.94	2.90	.28																													

\*-Length includes front or rear extensions when specified.  $\text{in}^3$ -Inches cubed per side member.  
 ○ -Structural cross members; Those which are so attached as to resist torsional frame stresses.  
 † - Frame used on 4100 with Heavy Duty Equipment.  
 10-29-54

### FRONT AXLE

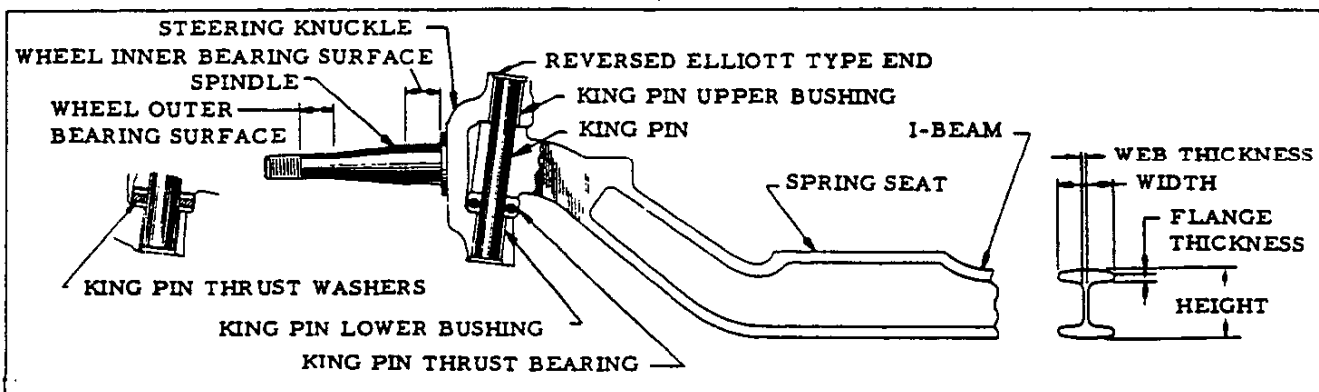

ITEM	3100	3600	3800	4100 4400	3700 3900	4100, 4400 (RPO-203)	4500 6000	5000	
Type	Reverse Elliott type (modified I-beam section)								
Rated capacity (pounds)	2200	2500	3500	4000		4500			
I-beam (average dimen- sions)	Height	2-1/8	2-1/4		2-1/2		2-5/8		
	Width	1-3/4	2						
	Flange thickness	7/32	5/16		7/16				
	Web thickness	1/4	11/32		1/4		3/8		
	Section modulus	.70 in. <sup>3</sup>	1.14 in. <sup>3</sup>		1.48 in. <sup>3</sup>		1.61 in. <sup>3</sup>		
King pin	Diameter	.8660-.8665		.9210-.9214		1.1090-1.1094			
	Bush- Type	Floating		Pressed into steering knuckle					
	Length x ID	1-5/16 x .867-.868	1-33/64 x .922-.923		1-3/8 x 1.110-1.111				
King pin thrust bearing	Type	Anti-friction bearings		Copper and steel washers					
	Diameter	Inside	See pages 171, 172		.927-.937		1.130 across flats after coining		
		Outside			1.547-1.557		2-1/32		
Spindle diameter	At inner bearing	1.2801-1.2806		1.4986-1.4991		1.7491-1.7496			
	At outer bearing	.7490-.7495		.9052-.9057		1.0291-1.0296			
Front wheel bearing	Anti-friction bearings --- See pages 171, 172								

### FRONT WHEEL ALIGNMENT

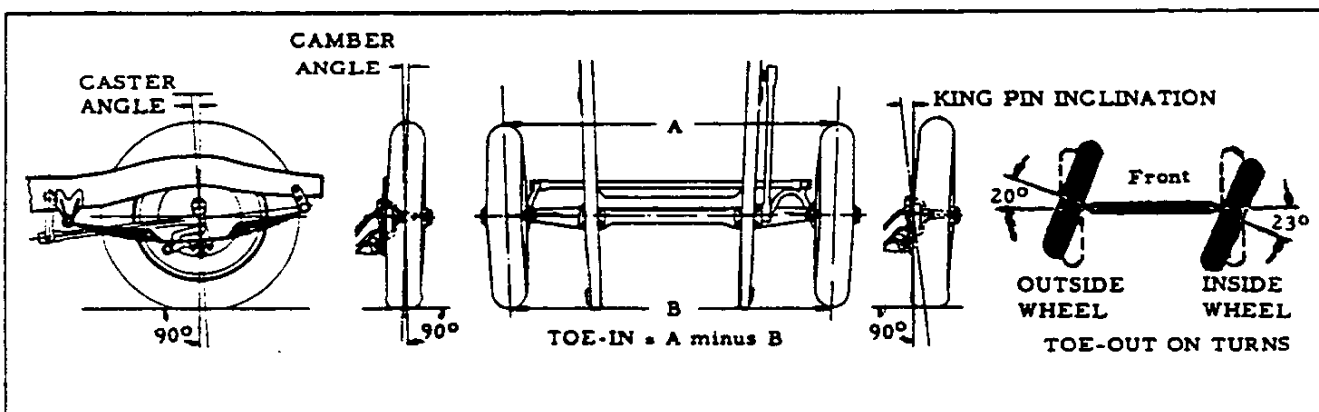

ITEM	3100	3600	3700	3900	3800	4000, 6000	5000
King-pin inclination	6°10'-8°10'						
Camber	0°30'-1°30'						
Caster at design load	1°15'- 2°15'	2°-3°	2°45'- 3°45'	1°45'- 2°45'	2°15'- 3°15'	2°15'- 3°15'	2°30'- 3°30'
Caster at curb weight	0°30'- 1°30'	0°15'- 1°15'	1°45'- 2°45'	1°10'- 2°10'	0°45'- 1°45'	0°15'- 1°15'	2°15'- 3°15'
Toe-in	1/16-3/16			1/16-1/4			
Toe-out on turns	Outside wheel		20°				
	Inside wheel		21°-25°				

## FRONT SUSPENSION

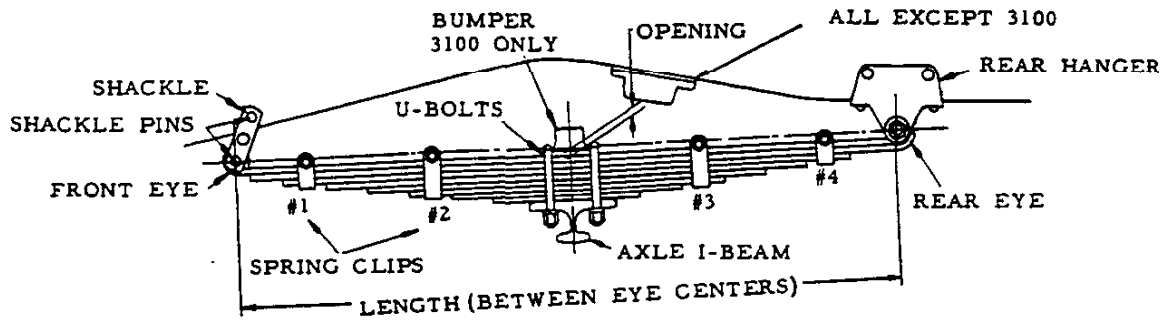

SPRING CLIP TYPES

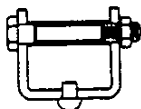

BOLT

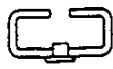

CLINCH



OVERHUNG EYE



BERLIN EYE  
1/2 WRAPPED



SCHOOL BUS ONLY  
DOUBLE WRAPPED EYE  
REAR OF RPO SPRING

SHACKLE TYPE

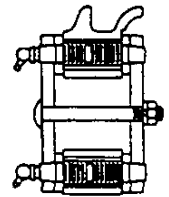

THREADED "H"

ITEM	3100	3600	3700 3900 (RPO 4100 4400)	3800	4100 4400	4500 6000	5100	5400 5700
<b>Springs</b>	Semi-elliptic							
Type	Chrome carbon steel							
Material	8							
Number							11	
Thickness	.237				.291			
(Leaves numbered from top to bottom)								
#1, 2, 3, 4, 5								
#6, 7								
#8								
#9								
#10, 11								
Total	1.896		2.328		2.037		2.619	
Load in pounds at opening height	810 to 890 @ 1/2		1215 to 1335 @ 7/8		950 to 1050 @ 1-3/16		1475 to 1625 @ 39/64	
Average rate of deflection (Pounds/inch)	315		575		495		640	
Capacity at pad (Pounds)	875		975		1550 *		1925	
Capacity at ground (Pounds)	1000		1150		1740 ⊕		2200	
Length x width	38 x 1-3/4				40 x 2			
Spring clip type (See figure)	#1 Clinch		#2 Clinch		#3 Clinch		#4 Bolt	
<b>Springs mountings</b>	Front		*		Front		Rear	
Shackle Located at	Threaded "H", .6595-.6645; 11 threads							
Pin, type & dia	Plain 7/8 OD							
Fixed end Bushing	11/16 OD x 3-3/8							
Bolt size	11/16 OD x 3-3/8				11/16 OD x 3-5/8			
U-bolt diameter	1/2		9/16		5/8			
Bumper	Rubber, on spring main leaf on 3100; frame side member for all others.							
Spring center-to-center	26-13/16 (Measured on axle I-beam)							
<b>Shock absorbers.</b>	Reg equip, direct double acting				RPO, direct double acting			
Type	808M				682P			
Model	4E6/J1				O3J10/C2			
Valve code	1				1-3/8			
(Pistons) Piston diameter	On models 3102-05-06-12-16, 3742, 3942. Frame to front springs.							
<b>Ride stabilizer</b>	On models 3102-05-06-12-16, 3742, 3942. Frame to front springs.							

\*-Shackle location: 3700 & 3900, Rear; 4100 & 4400, Front.

⊕-4100 & 4400 RPO, 1900 lb capacity at ground. \*-4100 & 4400 RPO, 1650 lb capacity at pad.

10-29-54.

## REAR AXLE

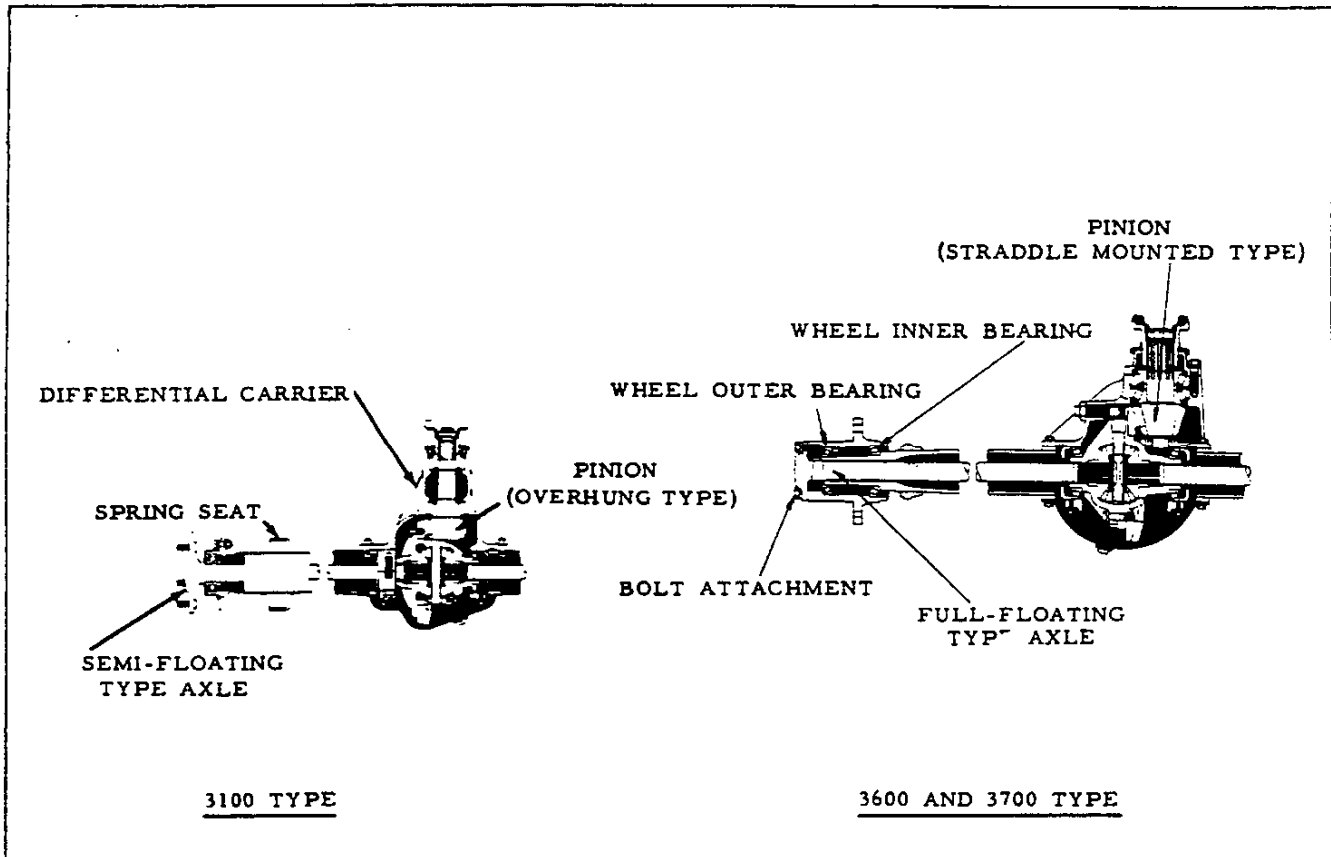

ITEM		3100	3600	3600 RPO	3700
Type		Semi-floating	Full-floating		
Rating (pounds)		3300	5000		
Housing	Type	Banjo			
	Construction	Pressed two pc welded	One piece or two piece welded		
	Material	HR Steel	Seamless steel tubing		
Final gears	Type	Spiral Hypoid			
	Ratio	3.90:1	4.57:1	5.14:1	
	Teeth	39 & 10	32 & 7	36 & 7	
Gear backlash		.005-.008			
Pinion	Mounting	Overhung	Straddle		
	Adjustment	shims			
	Thrust	against pinion rear brg	against pinion front brg		
*Max gear reduction in low gear	3-Speed Trans.	11.47	13.44	15.11	15.11
	3-Speed HD	12.36	14.49	16.29	16.29
	Automatic	14.90	21.54	24.23	24.23
	4-Speed	27.53	32.26	36.29	36.29
Ø Max axle shaft torque in low gear	3-Speed Trans.	190 <sup>1</sup>	2228	2504	2415
	3-Speed HD	204 <sup>9</sup>	2402	2700	2603
	Automatic	2470	3570	4016	3872
	4-Speed	2656 <sup>0</sup>	5347	6015	5799
Lubricant capacity		5 pints	6 pints		
Differential type		Two pinion	Four pinion		
Axle shaft	Type	Shaft and drive flange integrally forged			
	Minimum dia	1.156	1.343		
	Hub attachment	Integral	Bolted		
Drive taken through		Springs (Hotchkiss)			
Torque taken through					
Anti-friction bearings		See pages, 171, 172			

\* - Axle ratio x transmission ratio

<sup>0</sup> - Maximum capacity of shafts

<sup>9</sup> - Gear reduction x engine maximum net torque x efficiency factor (.90 in direct drive, .85 all others.)

CONTINUED

10-29-54

138 - REAR AXLE

CHEVROLET 1955 SPECIFICATIONS—TRUCK

REAR AXLE—Continued

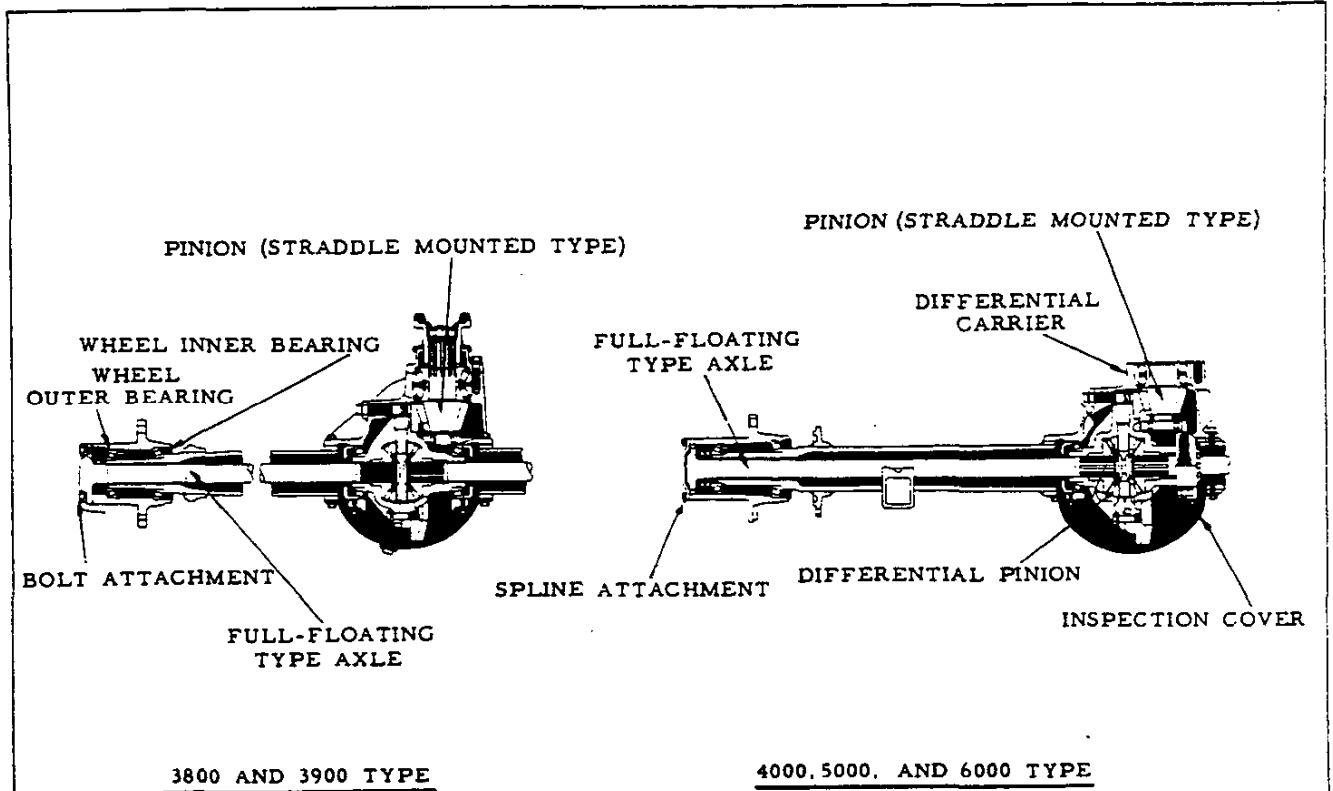

ITEM	3800	3900	4000 RPO	4000	5000	6000
Type	Full-floating					
Rating (pounds)	7200		11000		13000	
Housing	Type Banjo					
	Construction One pc or two pc welded		One pc pressed stl welded		One pc or two pc welded	
	Material Seamless steel tubing		HR Steel		Steel tubing	
Final gears	Type Spiral Hypoid					
	Ratio 5.14:1		5.43:1		6.17:1	
	Teeth 36 & 7		38 & 7		37 & 6	
Gear backlash	.005-.008					
Pinion	Mounting Straddle					
	Adjustment Shims		None			
	Thrust Against pinion front bearing					
*Max Gear	4-Speed 36.29		38.34		43.56	
Reduction	Automatic 24.23					
in low gear	3-Speed HD 16.29					
Ø Max Axle Shaft Torque in Low gear	4-Speed 6015 5799		6355 7220		6961 7220	
	Automatic 4016 3872					
	3-Speed HD 2700 2603					
Lubricant capacity	6 pints		11 pints		12 pints	
Differential type	Four pinion					
Axle shaft	Type Shaft and drive flange integrally forged					
	Minimum dia 1-11/32		1-7/16		1-11/16	
	Hub attachment Bolted		Splined			
Drive taken through	Springs (Hotchkiss)					
Torque taken through	See pages 171, 172					
Anti-friction bearings	See pages 171, 172					

\* - Axle ratio x transmission ratio.

Ø - Gear reduction x engine maximum net torque x efficiency factor (.90 in direct drive, .85 all others.)

⊙ - RPO - 261 cu. in. Jobmaster engine.

10-29-54

CHEVROLET 1955 SPECIFICATIONS—TRUCK



## REAR SUSPENSION

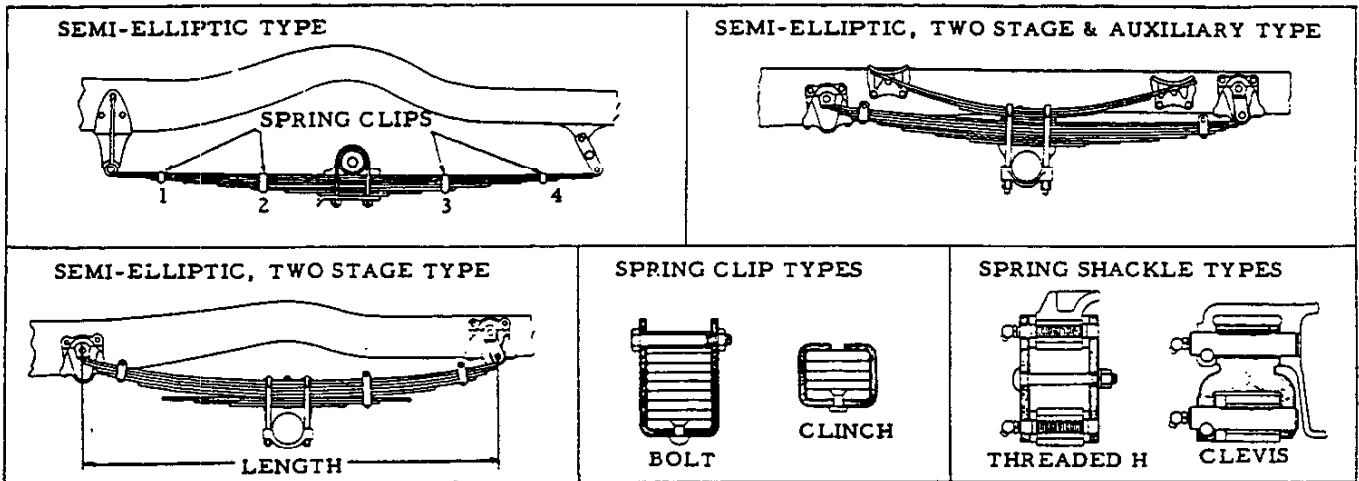

ITEM		3100	3100 RPO	37-3900	3600	3600 RPO	3800	3800, 3900 RPO	3802 RPO	
Springs	Type	Semi-elliptic			Semi-elliptic two-stage		Semi-elliptic two-stage and auxiliary		Semi-elliptic	
	Leaves	Chrome carbon steel								
	Material	Chrome carbon steel								
	Number	8	10	8	7(4 & 3)	8(5 x 3)	3(aux)	9		
	Thickness (Leaves numbered from top to bottom)	#1, 2			.323					
		#3					.291			
		#4							.323	
		#5							.291	
		#6, 7	.291							
		#8								
		#9								
	Total	2.328	2.910	2.392	2.133	2.424	.969	2.715		
	Load in pounds at opening height	940 - 1040 @ 5/8	1215 to 1315 @ 3/4	1735 to 1915 @ 25/32	1325 to 1475 @ 9/16	1510 to 1660 @ 9/16	1575 to 1725 @ 1-29/32		2205 to 2435 @ 13/16	
	Average deflection rate (pounds per inch)	190	250	400	250 @ 200-600#; 370 @ 1200 to 1600 #	315 @ 250-750#; 435 @ 1400-1800#	620	470		
	Capacity at pad (lb)	1250	1600	1950	1725	2175	3225	2300		
Capacity at ground (lb)	1450	1800	2250	2000	2500	3675	2650			
Length x width	54-1/8 x 1-3/4			46 x 2		31 x 2	46 x 2			
Spring clip type (see fig.)	Clinch Bolt 1-2-3-4			1-3-4		1-4	1-2-3-4			
Spring mountings	Shackle end	Located at		Rear						
	Type	Threaded H		Clevis and plain bushing						
	Pin size	5/8-11 Thread		7/8 dia						
	Fixed end	Bushing		7/8 ID						
	Pin or bolt	Plain, 11/16 ID		7/8 dia (pin)						
	Attachment to axle	Two U-bolts and cap								
	U-bolt diameter	1/2		5/8						
	Bumper	Rubber, mounted on frame side member lower flange								
Center to center	42-9/16			41-1/2						
Ride stabilizer	Included in shock absorber RPO on model 3942 with 7.50-17 or 7.00-18 tires									

### REAR SHOCK ABSORBERS

ITEM	3100	3600	3700	3800	3900
Direct double-acting	Regular equipment			RPO (200)	
Model and valve code	843V, 3J88/C2	843T, 3J88/D3		660X, 04N10/A1	
Cam and lever double-acting					RPO (200)
Valve code	Compression				GO
	Rebound				IR
Piston diameter	1			1-3/8	1-1/2

10-29-54

140 - REAR SUSPENSION

CHEVROLET 1955 SPECIFICATIONS—TRUCK

### REAR SUSPENSION—Continued

SEMI-ELLIPTIC, HEAVY DUTY TYPE

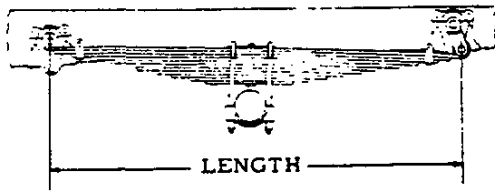

SEMI-ELLIPTIC, TWO-STAGE TYPE

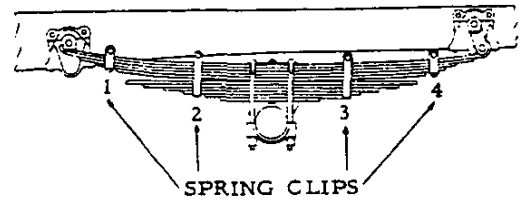

SEMI-ELLIPTIC AND AUXILIARY TYPE



SPRING CLIP TYPES

CLEVIS TYPE SHACKLE

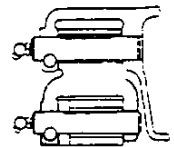

BOLT

CLINCH

ITEM	4500, 6700, 6800 Reg. 4100, 4400, 5000 RPO 6100, 6400, 6500 RPO	4100, 4400	5000, 6100, 6400, 6500 Reg. 4100, 4400 RPO
Springs	Semi-elliptic two stage		Semi-elliptic & auxiliary
Type	Semi-elliptic		
Material	Chrome carbon steel		
Leaves	11 (5 & 6)		11
Number	11 (5 & 6)		6 (aux.)
Thickness	#1, 2 #3, 4, 5 .323		.323
(Leaves numbered from top to bottom)	#6 #7 #8 #9 #10 #11		.360
Total	3.849		3.960
Load in pounds at opening height	3800 to 4200 @ 1-3/8		4370 to 4830 @ 1/4
Average deflection rate (pounds per inch)	625 @ 500-1000# 1100 @ 1500-4500#		1200
Capacity at pad (lb)	5000		7100
Capacity at ground (lb)	5000		7800
Length x width	46 x 2-1/2		31 x 2-1/2
Spring clip type: Clinch (see figure)	Bolt: -2-)-4		1-4
Shackle end	Rear		
Located at	Type: Clevis and plain bushings		
Type	Pin size: 7/8 dia		
Pin size	Fixed end: Bushing: 7/8 ID		
Bushing	Pin: 7/8 dia		
Pin	Spring to axle attachment: Two U-bolts and cap to fixed metal seat on axle housing		
Spring to axle attachment	U-bolt diameter: 3/4		
U-bolt diameter	Bumper: Rubber, mounted on frame side member lower flange		
Bumper	Spring center to center: 42		
Spring center to center			

### REAR SHOCK ABSORBERS

ITEM	4000, 5000, 6700, 6800, RPO 200
Shock absorbers	Type: Direct double-acting
Type	Piston diameter: 1-3/8
Piston diameter	Model & Valve Code: 660x, 04 N10/A1
Model & Valve Code	

10-29-54

**TWO-SPEED REAR AXLE (RPO 243 FOR 4000, RPO 201 AND 202 FOR ALL 5000-6000 MODELS)**

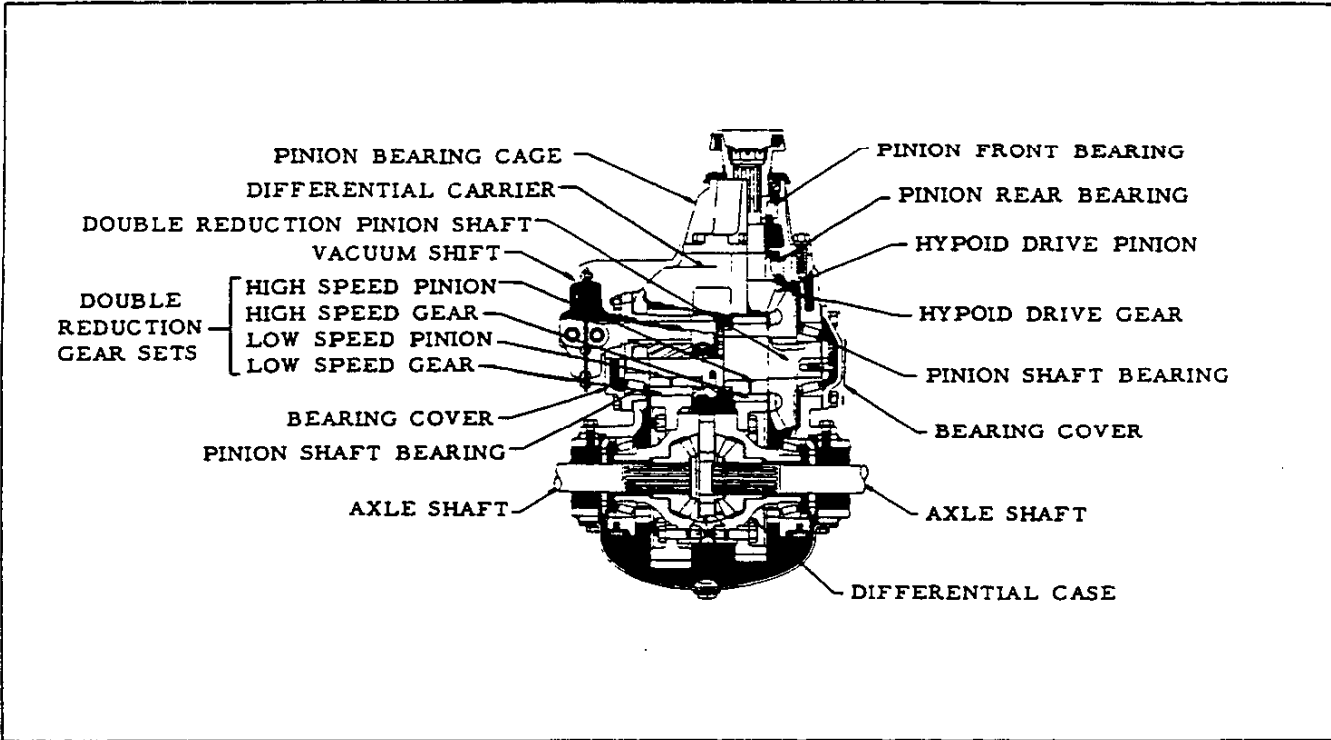

**AXLE CONTROL DECAL ON INSTRUMENT PANEL Ⓞ**

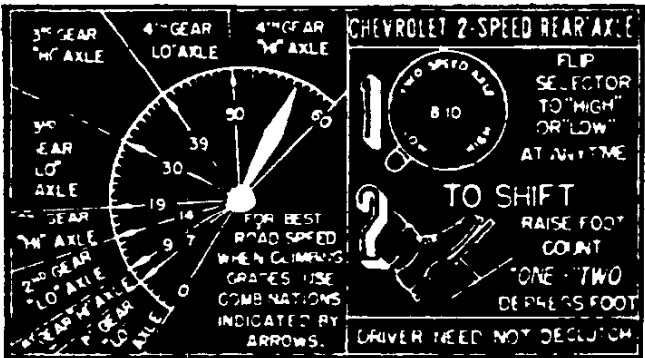

**DECAL SHOWN FOR RPO 202 AXLE**

**Axle shafts:**

- Material ----- Hot rolled, forged steel
- Type ----- Shaft and drive flange integrally forged ----- Spline attachment
- Minimum diameter ----- 1-11/16
- Anti-friction bearings ----- See pages 171, 172
- Vacuum shift ----- On instrument panel

**PRIMARY DRIVE GEARS**

- Type and Ratio ----- 201-Hypoid, 3.143:1 Ratio
- 202 & 243-Hypoid, 2.875:1 Ratio
- Pinion (overhung mounted) ----- 201-7 teeth;
- 202 & 243-8 teeth;
- Drive gear (straddle mounted) ----- 201-22 teeth;
- 202 & 243-28 teeth;
- Back lash adjustment ----- .008 to .013,
- by shims at double reduction pinion shaft cover.

**DOUBLE REDUCTION GEARS**

- Type ----- Helical spur
- Ratio: High speed ----- 2.133:1 (32-15 teeth)
- Low speed ----- 2.818:1 (31-11 teeth)
- Lubricant capacity, refill (pints) ----- 14-1/2

**GENERAL DATA**

- Type ----- Double reduction, full-floating
- Rating (pounds) ----- 13000
- Final gear ratios ----- 201-6.70:1 High; 8.86:1 Low;
- 202 & 243-6.13:1 High; 8.10:1 Low;
- Drive torque ----- Through springs
- Housing ----- 201-Banjo, two piece welded steel tube;
- 202 & 243-Banjo, one-piece seamless steel tube

ITEM	RPO	4000		5000		6000		
		High	Low	High	Low	High	Low	
Maximum gear reduction in low transmission gear*	201			47.30	62.55	47.30	62.55	
	202			43.28	57.19	43.28	57.19	
	243	43.28	57.19					
Maximum axle shaft torque in low transmission gear Ⓞ	201	235 Engine		7559	9995	7840	10368	
		261 Engine		8242	10899	8644	11431	
	202	235 Engine		6916	9139	7174	9479	
		261 Engine		7542	9965	7909	10451	
	243	235 Engine	7174	9479				

\* - Rear axle ratio x transmission ratio.

Ⓞ - Total gear reduction x engine maximum net torque x efficiency factor (.85).

Ⓞ - Gear change points are for 8.25-20 tires.

10-29-54

## UNIVERSAL JOINTS AND PROPELLER SHAFTS

SERIES 3100-3600

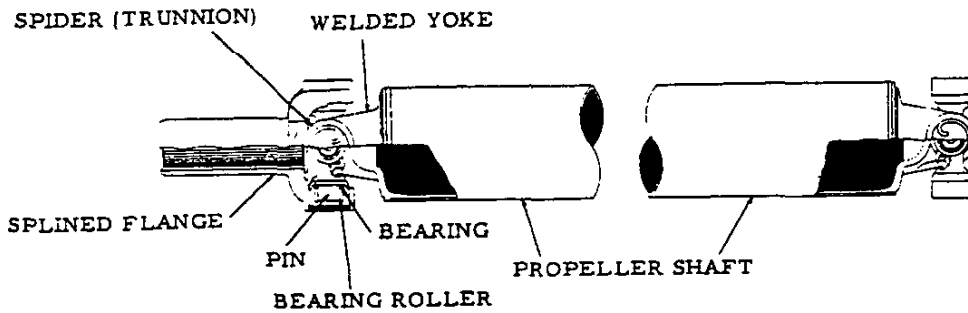

SERIES 3800-3900-4000-5400-5700-6100-6400

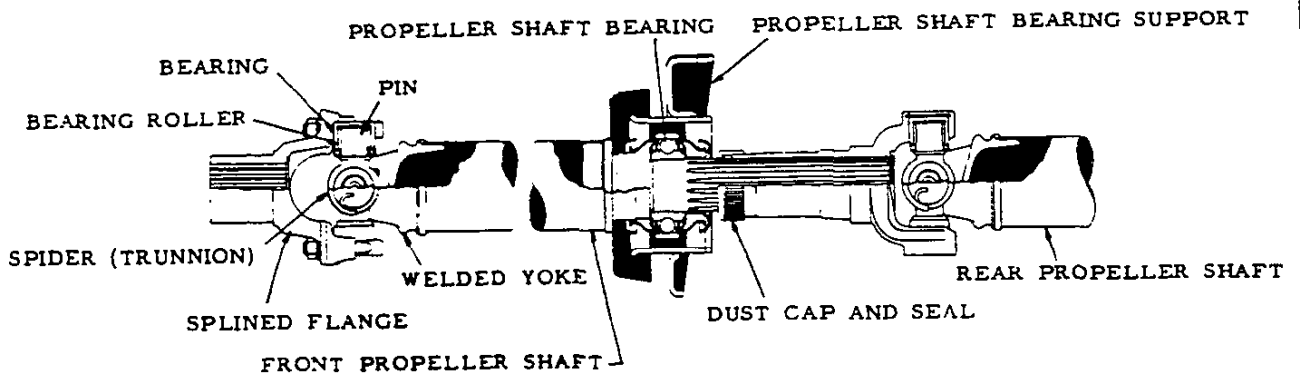

### UNIVERSAL JOINTS

ITEM		3100	3600 3700	38-3900 41-4400	5100	54-5700 61-6400	4500	65-67-6800		
Type and material		Yoke & trunnion, drop forged steel; trunnion case hardened								
Number used		2		3	2	3	4			
Pin diameter	Front	.5955-.5960		7730-.7735						
	Intermediate									
	Rear	.5955-.5960								
U-joint Trunnion bearings	Front	Anti-friction, See pages 171, 172								
	Intermediate									
	Rear									

### PROPELLER SHAFTS

Number used		1	2	1	2	3	
Type	Front			Tubular	Tubular		
	Intermediate						
	Rear	Tubular					
Outside diameter	Front			2-1/2	3	2-1/2	3
	Intermediate						
	Rear	3	3-1/2	2-1/2	3	2-1/2	3
Wall thickness	Front			.080-.088	.080-.088		
	Intermediate						
	Rear	.062-.068	.080-.088	.080-.085	.080-.088		
End type	Front	Front	Welded yoke		Welded yoke		
		Rear	Splined		Splined		
	Intermediate	Front			Welded yoke		
		Rear			Splined		
	Rear	Front	Welded yoke		Splined	Welded yoke	
		Rear			Welded yoke		
4502, 6702 6802 propeller shaft guard	Number used					2	3; 67-6800 only
	Type					U-bolt	
	Material					5/8 Round steel	
	Location and mounting					Support at front of each prop. shaft	
Support bearings pp 171, 172				1	1	2	

## DRIVE SYSTEM SPLINES—TRANSMISSION AND PROPELLER SHAFT

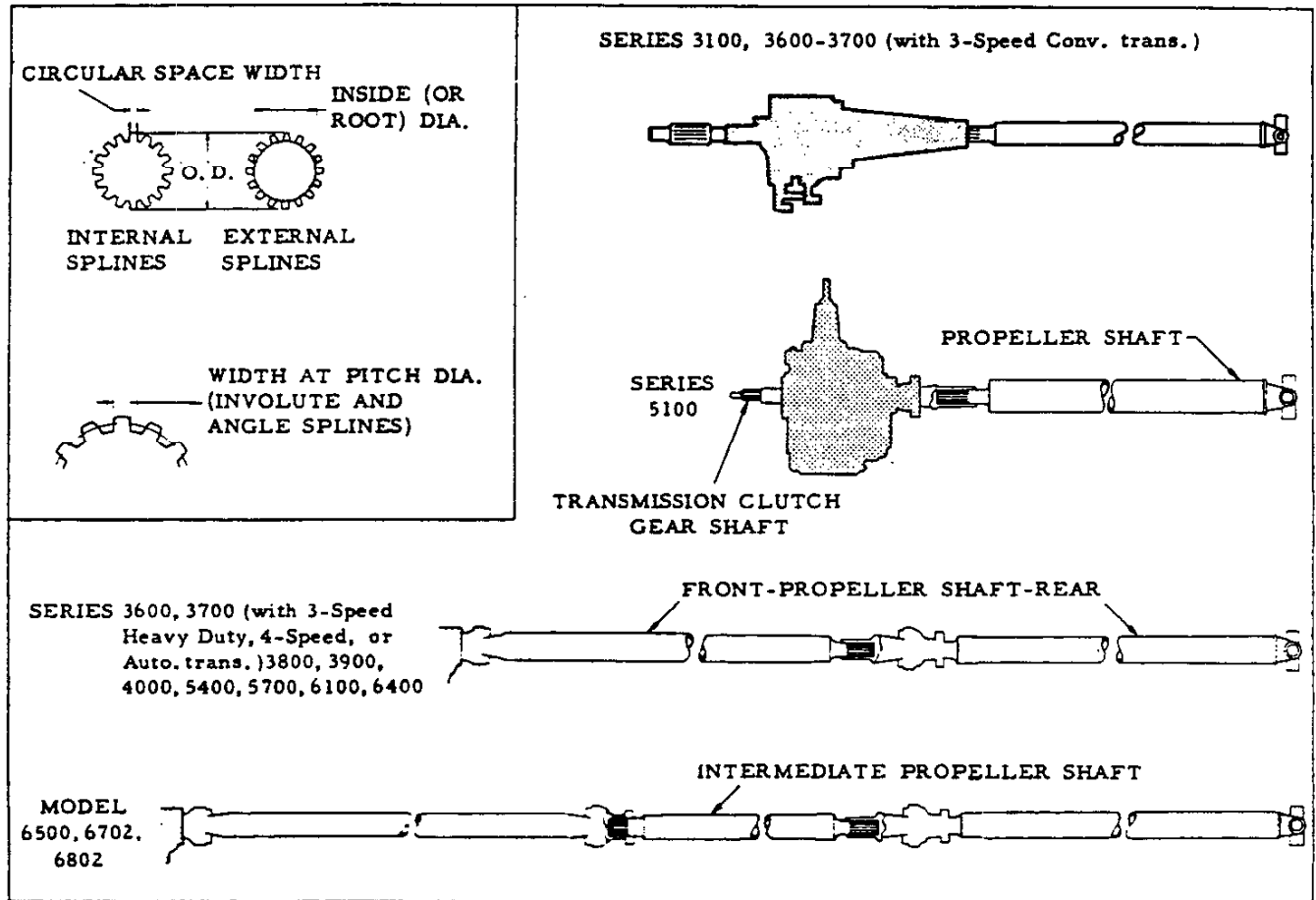

**CLUTCH DISC HUB AND TRANSMISSION CLUTCH GEAR SHAFT**

SERIES	ITEM	INTERNAL	EXTERNAL
3-4-5-6000	Width	.174-.176	.171-.173
	I. D.	.920-.925	.918 max eff.
	O. D.	1.134-1.144	1.110-1.121
	Splines	10 (Straight side)	

**FRONT PROPELLER SHAFT REAR END AND U-JOINT FRONT FLANGE**

SERIES	ITEM	INTERNAL	EXTERNAL
65-67-6800	Width	.2130-.2145	.2125-.2140
	I. D.	1.208-1.213	1.120-1.130
	O. D.	1.374-1.375	1.372-1.373
	Splines	10 (Straight side)	

**TRANSMISSION MAINSHAFT AND FRONT U-JOINT, FRONT 2-SLEEVE YOKE**

SERIES	ITEM	INTERNAL	EXTERNAL
3100 (with 3-spd conv or auto trans)	Width	.1135-.1150	.1095-.1130
	I. D.	1.034-1.039	.930-.949
36-3700 (with 3-spd conv trans.)	O. D.	1.1755-1.1765	1.1745-1.1750
	Splines	16 (Straight side)	

**FRONT PROPELLER SHAFT REAR END AND U-JOINT SLEEVE YOKE**

SERIES	ITEM	INTERNAL	EXTERNAL
36-3700 (with 3-spd HD, 4-spd, or auto trans)	Width	.1335-.1350	.1305-.1320
	I. D.	1.182-1.187	1.168-1.175
38-39-4000	O. D.	1.374-1.375	1.3725-1.3730
	Splines	16 (Straight side)	

**PROPELLER SHAFT FRONT END AND FRONT U-JOINT REAR SLEEVE YOKE**

SERIES	ITEM	INTERNAL	EXTERNAL
3100 (with 3-Speed H.D. & 4-speed trans.)	Width	.1455-.1476	.1430-.1445
	I. D.	1.295-1.300	1.281-1.288
	O. D.	1.495-1.500	1.4975-1.4980
	Splines	16 (straight side)	

**INTERMEDIATE PROPELLER SHAFT REAR END AND U-JOINT SLEEVE YOKE**

SERIES	ITEM	INTERNAL	EXTERNAL
65-67-6800	Width	.1335-.1350	.1305-.1320
	I. D.	1.182-1.187	1.168-1.175
	O. D.	1.374-1.375	1.3725-1.3730
	Splines	16 (Straight side)	

**TRANSMISSION MAINSHAFT AND FRONT U-JOINT FRONT FLANGE**

SERIES	ITEM	INTERNAL	EXTERNAL
36-3700 (with 3-spd HD, 4-spd or Auto. trans.) 38-39-4000; 5-6000	Width	.1964-.1979	.1939-.1954
	I. D.	1.155-1.158	1.123-1.125
	O. D.	1.373-1.376	1.350-1.360
10-29-54	Splines	10 (Involute)	

**PROPELLER SHAFT FRONT END AND U-JOINT SLEEVE YOKE**

SERIES	ITEM	INTERNAL	EXTERNAL
5100	Width	.1455-.1470	.1435-.1450
	I. D.	1.292-1.300	1.281-1.288
	O. D.	1.499-1.500	1.4975-1.4980
	Splines	16 (Straight side)	

## DRIVE SYSTEM SPLINES—REAR AXLE

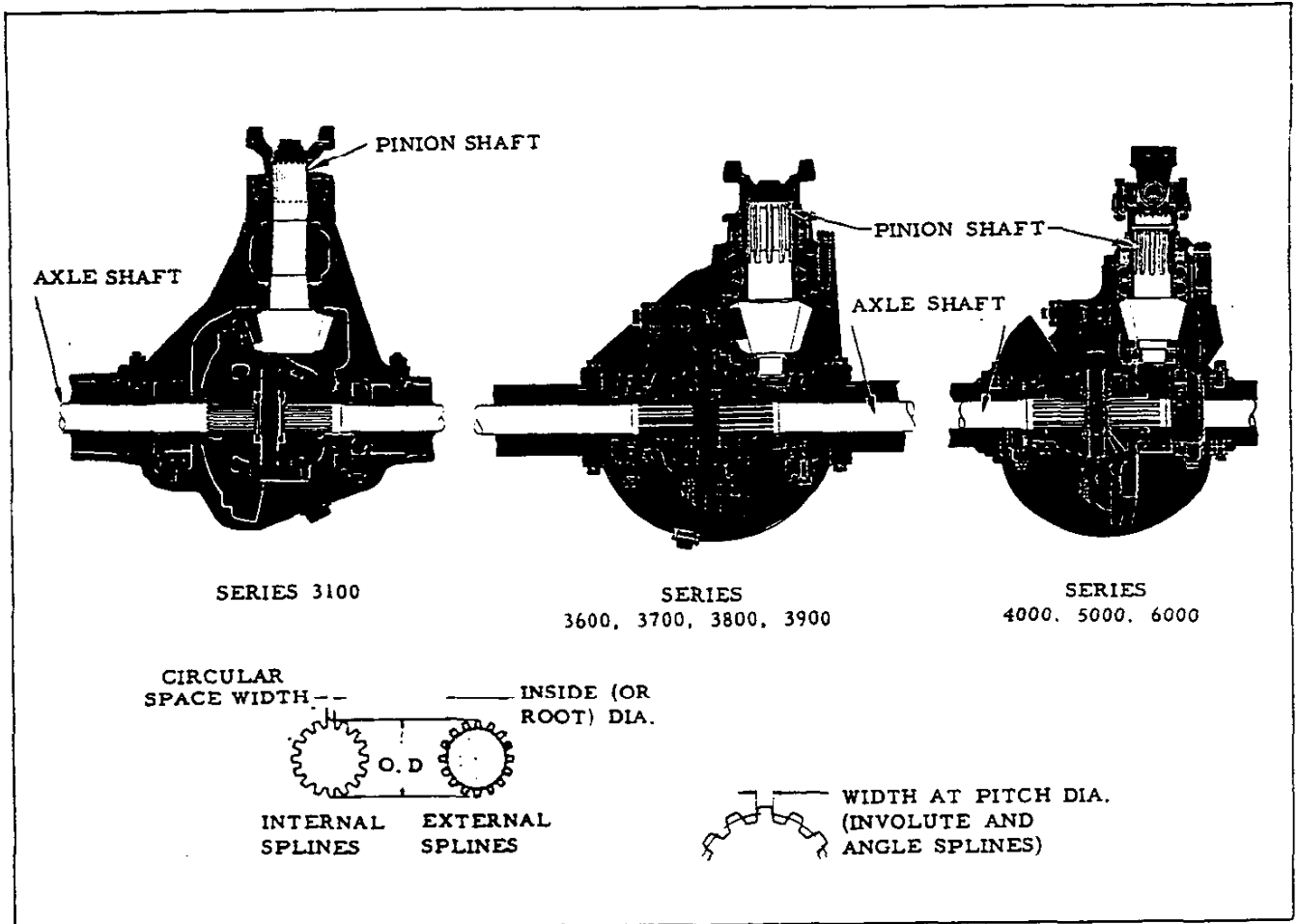

**PROPELLER SHAFT PINION FLANGE  
AND REAR AXLE DRIVE PINION SHAFT**

SERIES	ITEM	INTERNAL	EXTERNAL
3100	Width	.1144-.1154	.1124-.1144
	I. D.	1.194-1.198	1.156-1.164
	O. D.	1.3117-1.3132	1.309-1.311
	Splines	17 (Involute)	
*3600, 3700, 3800, 3900, *4000, 5000, 6000	Width	.302-.303	.300-.302
	I. D.	1.694-1.702	1.637-1.647
	O. D.	1.9675-1.9755	1.941-1.942
	Splines	10 (Straight side)	
4-5-6000 with RPO 2-speed Axle	Width	.2325-.2340	.232-.234
	I. D.	1.289-1.294	1.230-1.235
	O. D.	1.499-1.502	1.496-1.498
	Splines	10 (Straight side)	

**AXLE SHAFT FLANGE AND REAR WHEEL HUB**

SERIES	ITEM	INTERNAL	EXTERNAL
*4000	Width	.3106-.3116	.3086-.3106
	I. D.	3.295-3.305	3.245-3.255
	O. D.	3.795-3.805	3.765-3.775
	Splines	20 (Involute)	
5-6000 Reg. 4-5-6000 with RPO 2-Speed Axle	Width	.157-.158	.155-.157
	I. D.	3.910-3.915	3.860-3.870
	O. D.	4.213-4.218	4.185-4.195
	Splines	40 (Involute)	

**DIFFERENTIAL SIDE GEAR  
AND AXLE SHAFT**

SERIES	ITEM	INTERNAL	EXTERNAL
3100	Width	.1144-.1154	.1124-.1144
	I. D.	1.194-1.198	1.166-1.174
	O. D.	1.3005-1.3105	1.2795-1.2845
	Splines	17 (Involute)	
*3600, 3700 3800, 3900	Width	.1499-.1509	.1479-.1499
	I. D.	1.4245-1.4285	1.373-1.407
	O. D.	1.5485-1.5595	1.5275-1.5325
	Splines	17 (Involute)	
*4000	Width	.259-.262	.250-.258
	I. D.	1.472-1.477	1.440-1.450
	O. D.	1.6735-1.6785	1.6345-1.6445
	Splines	10 (Straight side)	
5-6000 with regular production axle	Width	.1001-.1011	.0981-.1000
	I. D.	1.752-1.756	1.689-1.693
	O. D.	1.876-1.880	1.848-1.856
	Splines	29 (Involute)	
4-5-6000 with RPO 2-Speed Axle	Width	.0943-.0953	.0981-.1000
	I. D.	1.754-1.756	1.689-1.693
	O. D.	1.876-1.880	1.848-1.856
	Splines	29 (Involute)	

\* - With regular or RPO axle

### BRAKES

ITEM		3100	3600	3700	3900	3800	4000	5000	6000		
Parking brake	Type	Mechanical. Rods and cables to rear brakes					Mechanical. Drum on prop shaft				
	Actuated by	Foot pedal					Hand lever				
	Control location	LH side of clutch pedal on floor					Trans. LH of pedals Trans.				
	Drum	Diameter	11	12	14		Inner 9.5, Outer 10				
		Area (eff.)	121	151	220		138 sq. in.				
	Lining	Material	Full molded asbestos composition								
Clearance		See adjustment for rear service brake					.010 to .015; both shoes				
Area (eff.)		74	93	137		35					
Service brake	Type	Servo-type, Single-anchor					2-cyl. balanced, servo-type				
Drum	Type	Front	Composite. Cast alloy iron rim, pressed steel web					One-piece, cast alloy iron			
		Rear									
	Dia.(Front, Rear)	Front	11	12	12 & 14		14 & 15				
		Rear	138	151	151		220				
	Total area in sq. in. (effective)	Front	121	151	220		377				
		Total	259	302	371		597				
Lining	Material	Full molded asbestos composition									
	Width	Front	2	2	2		2-1/2				
		Rear	1-3/4	2	2-1/2		4				
	Thickness before grinding	Front	.202-.222	.267-.287	.267-.287		.267-.287				
		Rear			.267-.287		.392-.412				
	Adjust to slight drag and:	Front	Back off 7 notches	Back off enough to eliminate drum drag, but no more than 7 notches			Back off 1 to 2 notches				
		Rear									
	Attachment	Bonded					Riveted				
	Lining area in sq. in. (effective)	Front	84	93	93		134				
		Rear	74	93	137		241				
Total		158	186	230		375					
Braking effort	Front	56%	50%	45%		34%					
	Rear	44%	50%	55%		66%					
Approx braking ratio	Pedal	6.330		6.785		6.330		6.534	6.330		
	Hydraulic	7.16	8.00	8.92	8.94	7.72					
	Overall	45.32	50.64	54.28	60.64	56.57	48.87	50.44	48.87		
Foot pedal	Travel	7.937		7.875		7.937					
	Pad cover	Molded rubber									
Wheel cylinder	No. of cylinders	Front	2					2			
		Rear	2					4			
	Dia-meter	Front	1-1/8					7/8			
		Rear	1	1-1/8	1-1/4		1-1/2				
Piston travel	.175	.156	.140		.162						
Main Cylinder	Diameter	1-1/8					1-1/4				
	Piston travel	1-1/2									
Brake fluid capacity	Approximately 1 pint										
Brake fluid recommended	Delco. Super #11										

### BRAKE BOOSTER EQUIPMENT

ITEM		4000	5000	6000
Brake booster equipment (hydraulic)	Available as	RPO 212	Standard equipment	
	Type	Single piston, vacuum suspended, reactionary valve		
	Power distribution	At 1000 PSI line pressure, distribution is 37% by pedal, 63% by booster		
Vacuum power reserve tank	Pedal pressure (actual test)	At 1000 PSI line pressure, pedal pressure is 204 lbs without booster, 80 lbs with booster.		
	Available as	RPO 281: on 4100 with RPOs 212 & 233; on 4400 & 4500 with RPO 212	RPO 281	
	Size	24 long x 7-1/2 ID; 1000 cu. in. capacity		
	Location	Clamped to outside of left side rail		

10-29-54.

### ENGINE—GENERAL

#### Basic Design Data

ITEM	3100	3600	3800	4100 4400	4502	3700	3900	5000	4000 RPO 6000 Reg	6702 6802	5000 RPO 6000 RPO
Piston displacement	235.5 cu. in.										261 cu. in.
Bore and stroke (Nominal)	3-9/16 x 3-15/16										3-3/4 x 3-15/16
Type	Valve-in-head, 6-cylinder										
Compression ratio	7.5:1										7.17:1
Taxable (SAE) horsepower	30.4										33.7
Idling speed	475 RPM										
Comp. pressure (Engine hot)	130 PSI or better at cranking speed										
Dry weight (pounds)	Engine and clutch	604			612			614			616
	with transmission	666	662	734	770	670	770	773			775
Governor equipment	RPO 241				Regular				RPO 241	Regular	RPO 241
Governor speed	2300 to 3200 RPM				35MPH				3200 RPM	35 MPH	3400 RPM

#### ADVERTISED MAXIMUM ENGINE PERFORMANCE

ITEM		3100, 3600, 3800, 4000	3700, 3900, 5000	(4000 RPO) 6000	RPO 5000	RPO 6000
Horsepower	Gross	112 @ 3700 RPM	110 @ 3600 RPM	112 @ 3700 RPM	125 @ 3800 RPM	135 @ 4000 RPM
	Net	105 @ 3600 RPM	102 @ 3600 RPM	105 @ 3600 RPM	114 @ 3600 RPM	123 @ 3600 RPM
Torque (ft lb)	Gross	200 @ 2000 RPM	192 @ 2000 RPM	200 @ 2000 RPM	215 @ 1200-2000 RPM	220 @ 2000 RPM
	Net	195 @ 2000 RPM	188 @ 2000 RPM	195 @ 2000 RPM	210 @ 1200-2000 RPM	215 @ 2000 RPM

#### ENGINE SPEED AND PISTON TRAVEL#

Series	Tire Size	Axle Ratio	Transmission Type	Engine RPM at one MPH				Piston Travel (ft / mi) 235.5 Eng. and 261 Eng.	Crankshaft (rev / mile)		
				Low	2nd	3rd	High				
3100	6.00-16	3.9:1	3-Speed	140	80	48		1881	2867		
			4-Speed	337	171	82	48				
			3-Speed Heavy Duty	151	84	48					
			4-Speed Automatic	183	126	69	48				
	3-Speed		139	79	47		1863	2839			
	4-Speed		334	169	81	47					
	3-Speed Heavy Duty		150	83	47						
	4-Speed Automatic		181	124	69	47					
	3-Speed	137	78	46		1830	2789				
	4-Speed	328	166	79	46						
	3-Speed Heavy Duty	147	81	46							
	4-Speed Automatic	178	122	67	46						
3600	15"	4.57:1	3-Speed	160	91	54			2145	3268	
			4-Speed	384	195	93		54			
			3-Speed Heavy Duty	173	95	54					
			4-Speed Automatic	257	165	84		54			
	3-Speed		163	93	55		2183	3327			
	4-Speed		391	199	95	55					
	3-Speed Heavy Duty		176	97	55						
	4-Speed Automatic		262	168	86	55					
	7.00-17			3-Speed	147	84	50			1964	2993
				4-Speed	352	179	85		50		
				3-Speed	158	87	50				
				4-Speed Heavy Duty							

Continued

10-29-54

**CHEVROLET 1955 SPECIFICATIONS—TRUCK**

**ENGINE - 147**



**ENGINE—GENERAL—Continued**

Series	Tire Size	Axle Ratio	Transmission Type	Engine RPM at one MPH				Piston Travel (ft / mi) 235.5 Eng. and 261 Eng.	Crankshaft (rev / mile)	
				Low	2nd	3rd	High			
3600	7.00-17	4.57:1	4-Speed Automatic	235	151	77	50	1964	2993	
	7.50-17		3-Speed	143	82	49		1910	2911	
			4-Speed	342	174	83	49			
			3-Speed Heavy Duty	154	85	49				
			4-Speed Automatic	229	147	75	49			
3600 RPO 3700 3800 3900	15"	5.14:1	3-Speed	180	103	61		2412 †	3675	
			4-Speed	432	219	105	61			
			3-Speed Heavy Duty	194	107	61				
			4-Speed Automatic	289	186	95	61			
	6.50-16		3-Speed	183	105	62		2456 §	3742	
			4-Speed	439	223	106	62			
			3-Speed Heavy Duty	197	109	62				
			4-Speed Automatic	294	189	97	62			
	7.00-17		3-Speed	165	94	56		2210	3367	
			4-Speed	396	201	96	56			
			3-Speed Heavy Duty	178	98	56				
			4-Speed Automatic	265	170	87	56			
	7.50-17		3-Speed	160	92	55		2149	3274	
			4-Speed	385	195	93	55			
			3-Speed Heavy Duty	160	92	55				
			4-Speed Automatic	258	165	85	55			
7.00-18	3-Speed					2125 ‡	3238			
	4-Speed	381	193	92	54					
	3-Speed Heavy Duty	171	94	54						
	4-Speed Automatic	255	164	84	54					
4000	6.50-20	5.43:1	4-Speed	388	197	94	55	2166	3301	
	7.00-20			377	191	91	53	2103	3204	
	7.50-20			365	185	88	52	2035	3101	
	6.50-20			441	224	107	63	2462	3751	
	7.00-20			428	217	104	61	2389	3640	
4-5-6000	7.50-20	6.17:1		414	210	100	59	2312	3523	
	8.25-20			400	203	97	57	2231	3400	
5000 6000	Y 9.00-20	2-Speed		382	194	92	54	2130	3245	
	7.50-20			6.13:1	412	209	100	58	2297	3500
				8.10:1	544	276	132	77	3035	4625
	8.25-20			6.13:1	397	202	96	56	2217	3378
				8.10:1	525	266	127	74	2929	4463
	Y 9.00-20			6.13:1	379	192	92	54	2116	3224
				8.10:1	501	254	121	71	2796	4261
	7.50-20			6.7:1	450	228	109	64	2511	3826
				8.86:1	592	302	144	84	3320	5059
	8.25-20		6.7:1	434	220	105	62	2423	3692	
			8.86:1	574	291	139	81	3204	4882	
Y 9.00-20	6.7:1	415	210	100	59	2313	3524			
	8.86:1	548	278	133	78	3058	4660			

‡ Engine RPM is determined by locating the figure for one mile per hour and multiplying by the desired miles per hour - MPH is determined by dividing the known engine RPM by the engine RPM for one mile per hour

§-Also known as N/V factor

§-3600 only. ‡- 3800-3900 only.

† 3600-3700 only.

Y-9.00 x 20 tires not available on 67-6800. Also platform, or platform and stake models.

10-29-54.

148 - ENGINE

**CHEVROLET 1955 SPECIFICATIONS—TRUCK**

## ENGINE PERFORMANCE

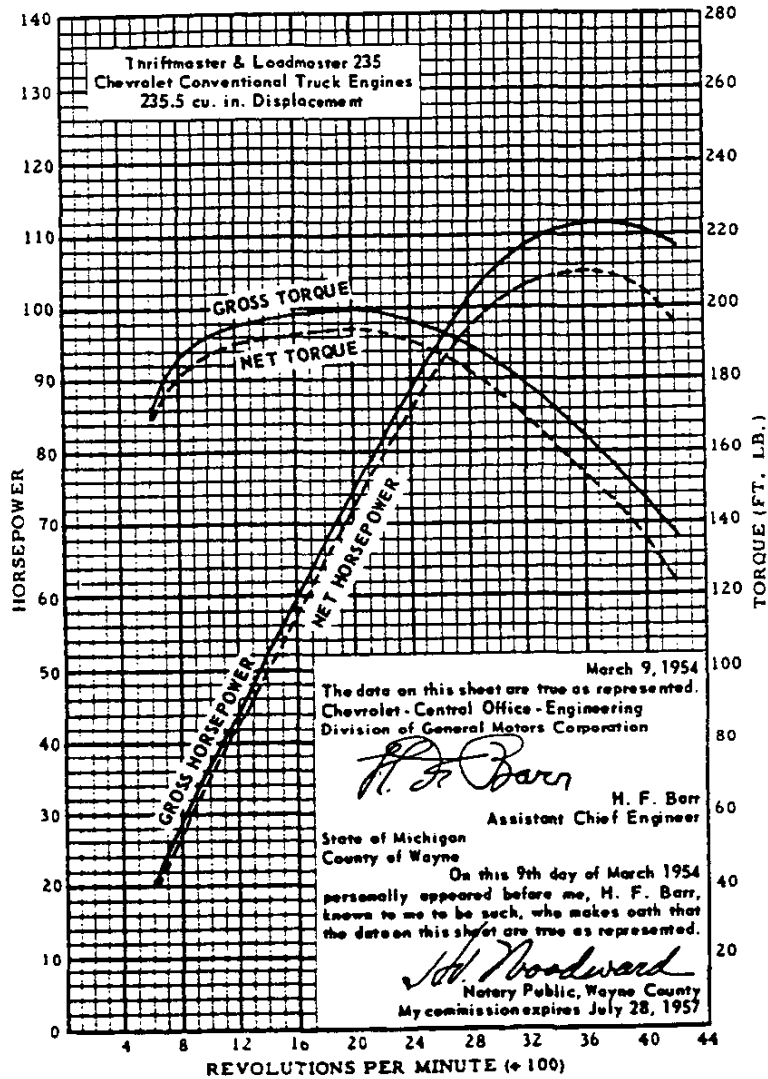

The engine performance curves shown on this sheet are taken from Chevrolet engine test reports 16670-124 and 16700-110. They represent the full throttle performance of a Thriftmaster and a Loadmaster Chevrolet conventional truck engine (235.5 cu. in. displacement) as obtained from dynamometer test data which were corrected to the standard barometric pressure 29.92" Hg. and the standard temperature of 60°F

ular dynamometer test with the dynamometer exhaust system, no fan, generator not charging, and optimum spark advance.

NET POWER and TORQUE were obtained from a dynamometer test simulating actual operating conditions when the engine is in its vehicle. It includes the use of the regular muffler and pipes, the fan in operation and automatic spark advance. The generator is not charging.

GROSS POWER and TORQUE were obtained in a regular dynamometer test with the dynamometer exhaust system, no fan, generator not charging, and optimum spark advance.

**CHEVROLET 1955 SPECIFICATIONS—TRUCK**

**ENGINE - 149**

## ENGINE PERFORMANCE

See page 149 for Loadmaster  
235 Engine Power Curve.

## ENGINE PERFORMANCE

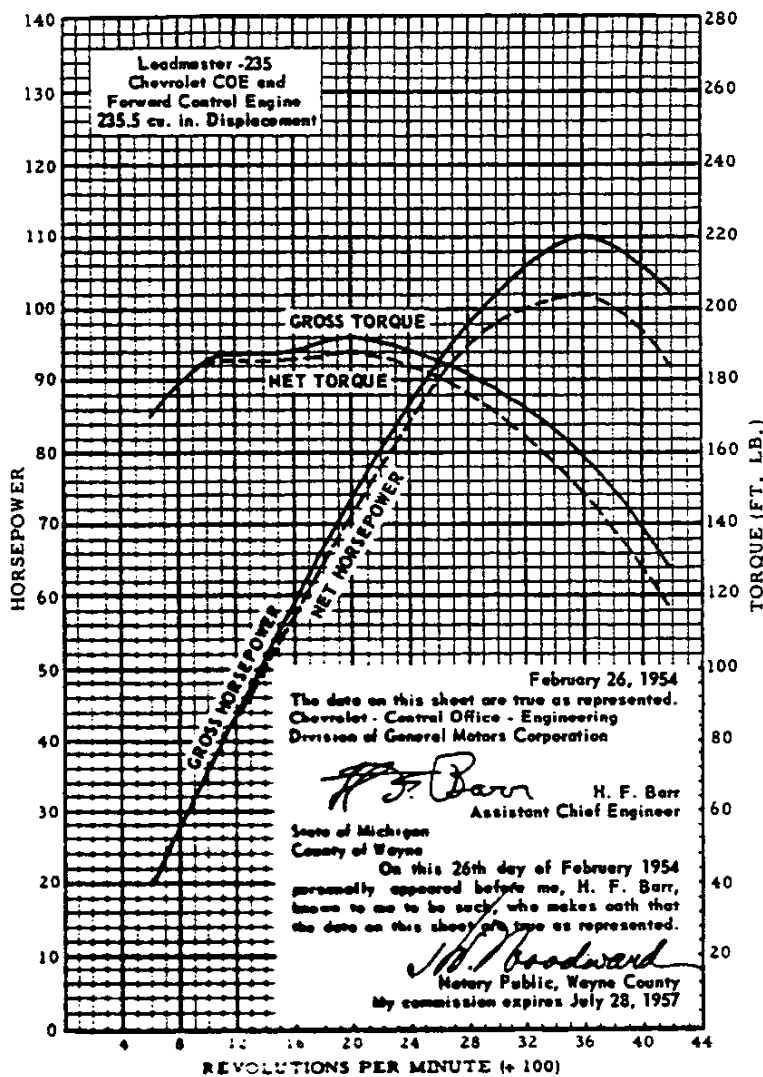

The engine performance curves shown on this sheet are taken from Chevrolet engine test report 16700-111. They represent the full throttle performance of a Leadmaster Chevrolet COE and Forward Control Truck engine (235.5 cu. in. displacement) as obtained from dynamometer test data which were corrected to the standard barometric pressure of 29.92" Hg and the standard temperature of 60°F.

GROSS POWER and TORQUE were obtained in a regular dynamometer test with the dynamometer exhaust system, no fan, generator not charging, and optimum spark advance.

GROSS POWER and TORQUE were obtained in a regular dynamometer test with the dynamometer exhaust system, no fan, generator not charging, and optimum spark advance.

**GROSS POWER and TORQUE** were obtained in a regular dynamometer test with the dynamometer exhaust system, no fan, generator not charging, and optimum spark advance.

**CHEVROLET 1955 SPECIFICATIONS—TRUCK**

ular dynamometer test with the dynamometer exhaust system, no fan, generator not charging, and optimum spark advance.

NET POWER and TORQUE were obtained from a dynamometer test simulating actual operating conditions when the engine is in its vehicle. It includes the use of the regular muffler and pipes, the fan in operation and automatic spark advance. The generator is not charging

**ENGINE—151**

## ENGINE PERFORMANCE

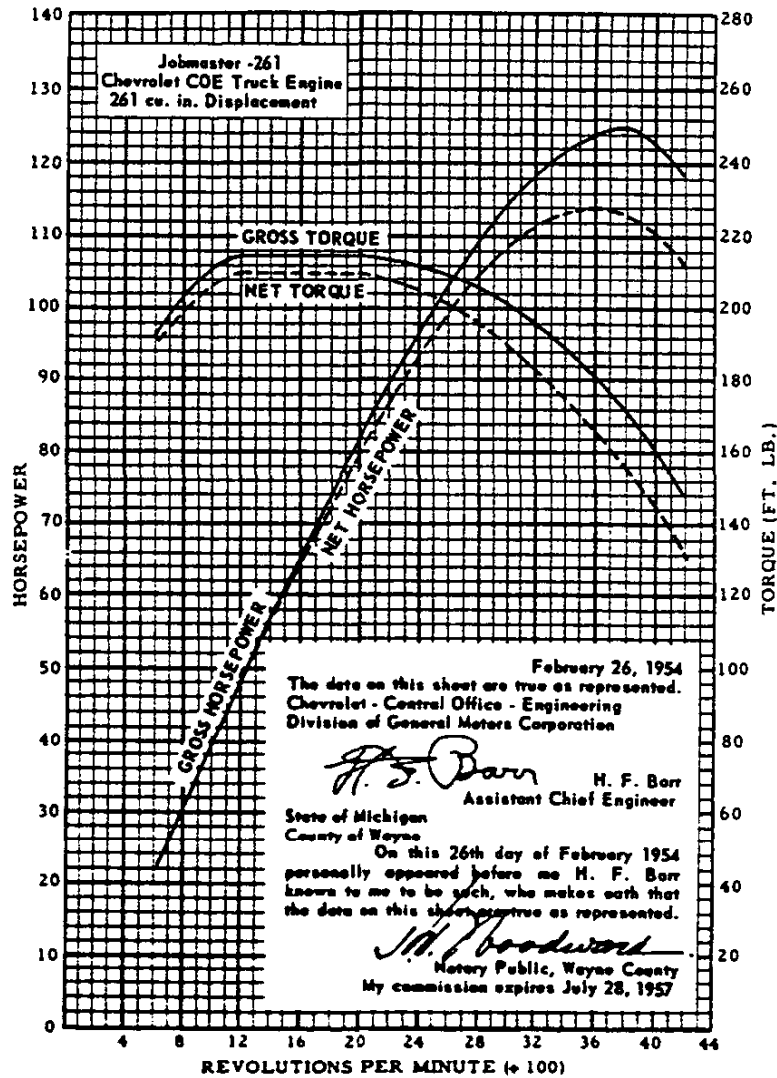

The engine performance curves shown on this sheet are taken from Chevrolet engine test report 16670-136. They represent the full throttle performance of a Jobmaster Chevrolet COE truck engine (261 cu. in. displacement) as obtained from dynamometer test data which were corrected to the standard barometric pressure of 29.92" Hg. and the standard temperature of 60°F.

GROSS POWER and TORQUE were obtained in a regular dynamometer test with the dynamometer exhaust system, no fan, generator not charging, and optimum spark advance.

10-29-54.  
152 —ENGINE

NET POWER and TORQUE were obtained from a dynamometer test simulating actual operating conditions when the engine is in its vehicle. It includes the use of the regular muffler and pipes, the fan in operation and automatic spark advance. The generator is not charging.

CHEVROLET 1955 SPECIFICATIONS—TRUCK

## ENGINE PERFORMANCE

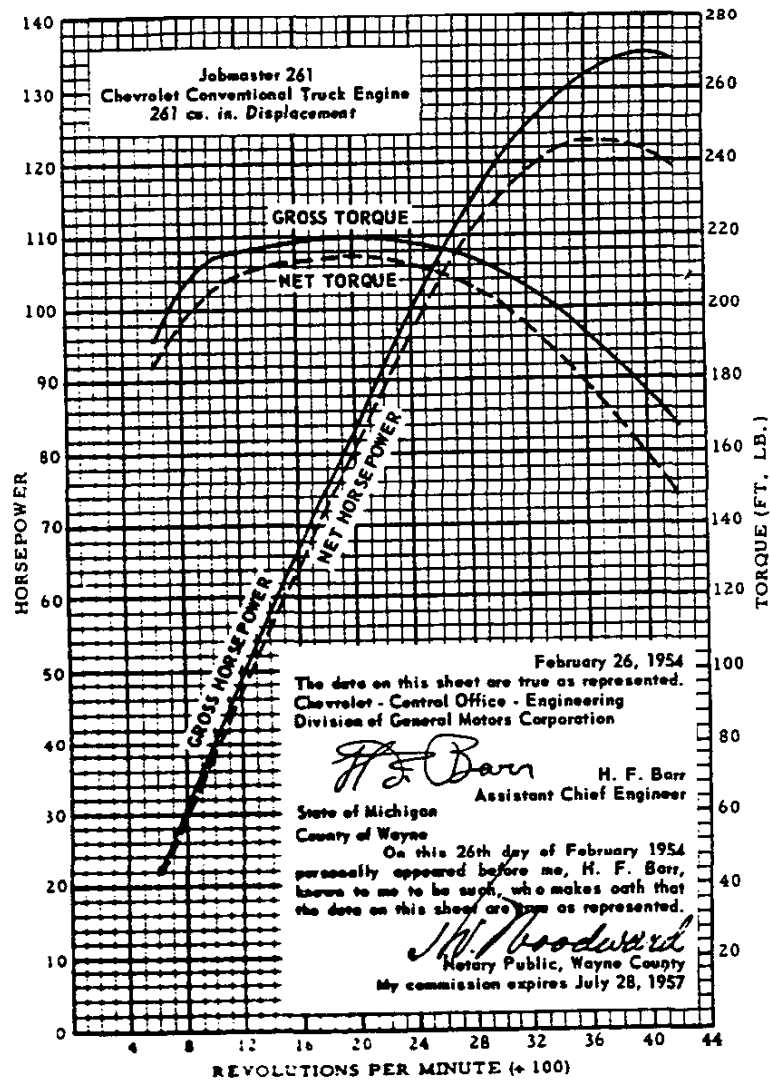

The engine performance curves shown on this sheet are taken from Chevrolet engine test report 16670-135. They represent the full throttle performance of a Jobmaster Chevrolet conventional truck engine (261 cu in. displacement) as obtained from dynamometer test data which were corrected to the standard barometric pressure 29.92" Hg. and the standard temperature of 60°F.

GROSS POWER and TORQUE were obtained in a regular dynamometer test with the dynamometer exhaust system, no fan, generator not charging, and optimum spark advance.

GROSS POWER and TORQUE were obtained in a regular dynamometer test with the dynamometer exhaust system, no fan, generator not charging, and optimum spark advance.

ular dynamometer test with the dynamometer exhaust system, no fan, generator not charging, and optimum spark advance.

NET POWER and TORQUE were obtained from a dynamometer test simulating actual operating conditions when the engine is in its vehicle. It includes the use of the regular muffler and pipes, the fan in operation and automatic spark advance. The generator is not charging.

ENGINE - 153

### CYLINDER AND CASE AND HEAD

Material ----- Cast alloy iron      Bore diameter:  
 Cylinder head bolt torque ----- 90-95 ft lb      235.5 Engine ----- 3.5620-3.5640  
 Offset ----- None      261.0 Engine ----- 3.7490-3.7510

### CRANKSHAFT AND BEARINGS

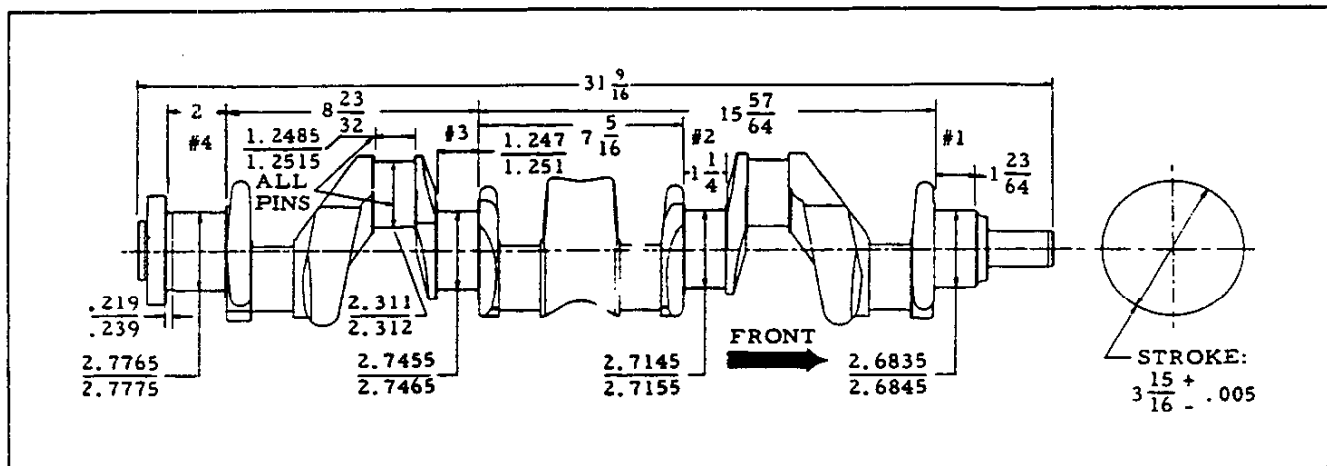

#### CRANKSHAFT

Material ----- Drop-forged steel  
 Weight ----- 235.5 Engine, 78.5 lb  
 End play ----- 0035-.0095  
 Counter weights ----- 7  
 Stroke ----- 3-1/16 ± .005

#### HARMONIC BALANCER (Vibration damper)

Type ----- Oscillating (Rubber-floated)  
 Crankshaft pulley pitch diameter ----- 5-7/8

#### MAIN BEARINGS

Material ----- .003-.006 babbitt on steel shell

Type ----- Precision interchangeable  
 Removable ----- From below  
 Necessary to align ream ----- No  
 Clearance ----- .0005-.0031 fit with solid shims  
 End thrust against ----- #3 bearing  
 Bearing bolt torque -----  
 ----- 100-110 ft lb with oiled threads

Brg	Inside Dia	Length	Proj. Area*
#1	2.6850-2.6866	1.093	2.345 sq. in.
#2	2.7160-2.7176	.936	2.019 sq. in.
#3	2.7470-2.7486	1.2415-1.2435	2.209 sq. in.
#4	2.7780-2.7796	1.219	2.776 sq. in.

\* - Based on effective length, i. e. overall length shown above, less oil groove and chamfers.

### CAMSHAFT AND BEARINGS

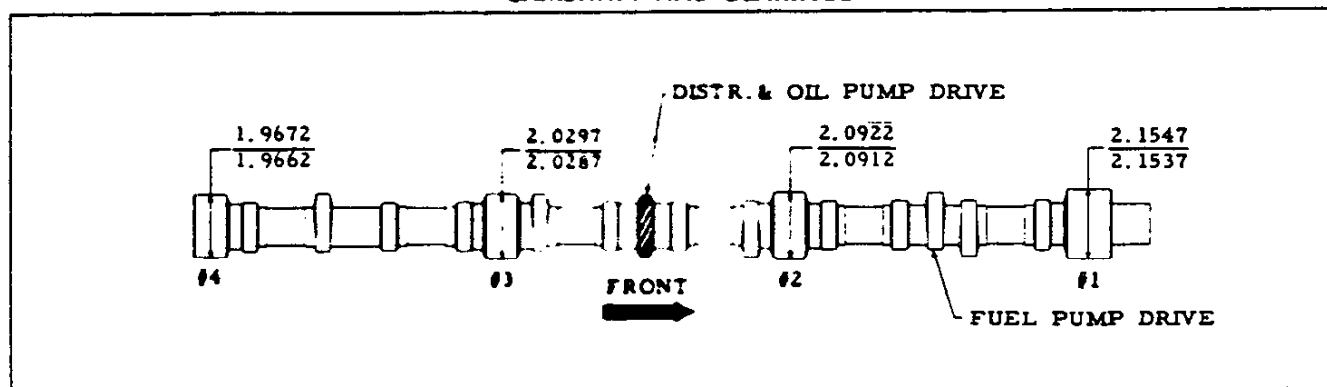

#### CAMSHAFT

Material ----- Cast alloy iron  
 End play ----- 003-.007  
 Ramp Inlet: 235.5 ----- 0111  
 261 ----- 0107  
 Ramp Exhaust: 235.5 ----- 0140  
 261 ----- 0148

#### DRIVE

Make and type ----- Chevrolet, helical gear  
 Driven gear (on camshaft) material ----- Aluminum alloy  
 Drive gear (on crankshaft) material ----- Steel

#### BEARINGS

Material ----- Steel-backed babbitt  
 Clearance on diameter ----- .0010-.0030  
 Thrust taken by ----- Thrust plate between driven timing gear and camshaft #1 journal front face.

Brg	Inside dia	Length	Proj Area Q
#1	2.1557-2.1567	1.12	2.415 sq. in.
#2	2.0932-2.0942	.94	1.968 sq. in.
#3	2.0307-2.0319	.94	1.909 sq. in.
#4	1.9682-1.9692	.94	1.846 sq. in.

Q - Based on overall length shown above.

## PISTON-PIN-RINGS

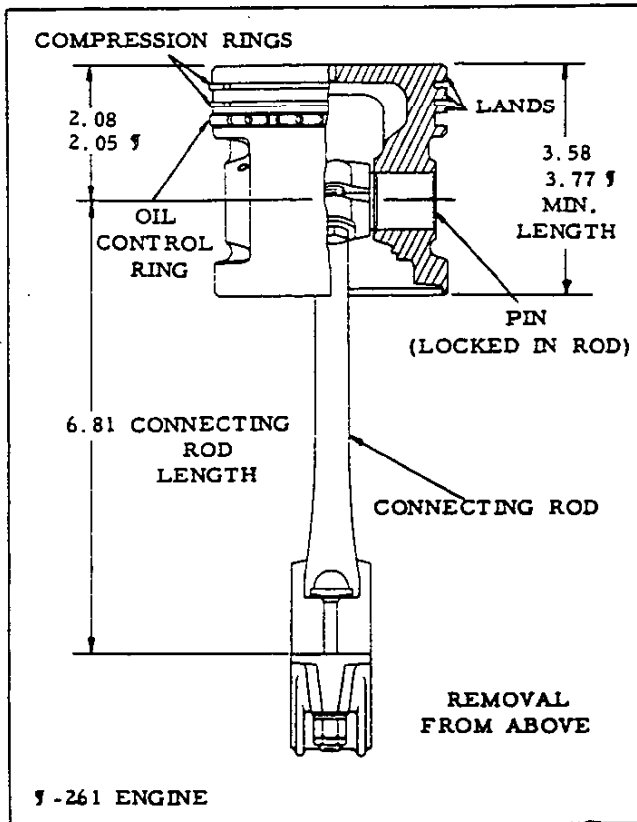

7 - 261 ENGINE	PISTON
Make-----	Own
Material-----	Cast alloy aluminum with steel struts
Features-----	Flat head, tin plated, oval with controlled thermo expansion
Skirt clearance in cylinder bore-----	.0005-.0011*
235.5 Engine:	
Land clearance in cylinder bore-----	.0115-.0155*
Compression ring groove depth-----	.184-.192
Oil ring groove:	
Depth-----	.179-.187
Holes, number and size-----	8, 5/32 drill
Head thickness at center-----	.235-.245
Piston pin bushings-----	None
Weight of piston-----	1.18 lb
Weight of piston, rings, pin and connecting rod upper end x 6 (units/engine)-----	12.50
261 Engine:	
Compression ring groove depth-----	.193-.201

Type-----	Rod clamps piston pin
Material-----	Drop-forged steel
Rod width at piston pin-----	1.126-1.129
Rod width at crankpin-----	1.2415-1.2435
Crankpin bearings:	
Type-----	Precision interchangeable insert
Material-----	Steel backed, thin wall babbitt
Diameter-----	2.3127-2.3138
Effective length (overall length less chamfers)-----	1.008
Clearance on diameter-----	.0007-.0028
Projected area per rod (based on effective length)-----	2.332 sq. in.
* Land clearance = cylinder bore dia minus land dia + 2	
* Skirt clearance = cylinder bore dia minus piston dia	

10-29-54  
CHEVROLET 1955 SPECIFICATIONS—TRUCK

Oil groove:	
Depth-----	.184-.192
Holes, number and size-----	8, 5/32 drill
Head thickness at center-----	.255-.265
Weight of piston-----	1.36 lb
Weight of piston, rings, pin and connecting rod upper end x 6 (units/engine)-----	14.51 lb

PISTON PIN	
Material-----	Chromium steel (file-hard case)
Diameter: 235.5-----	.8660-.8665
261-----	.9270-.9275
Length: 235.5-----	3.168-3.198
261-----	3.385-3.415
Taper limit in full length-----	.0002
Weight: 235.5-----	.320
261-----	.375
Clearance in piston-----	.00015-.00025

COMPRESSION RINGS	
Number per piston-----	2
Type:	
Upper-----	Thick wall, inside bevel
Lower:	
235.5 Loadmaster-----	Thick wall, inside bevel
261 Jobmaster-----	Thick wall, taper faced, scraper
Material-----	Cast iron (235.5 Loadmaster and 261 Jobmaster upper ring only)----- Chrome plated
Width: Upper-----	.0930-.0935
Lower: 235.5-----	.0925-.0930
261-----	.0930-.0935
Gap Clearance:	
235.5-----	.007-.017
261-----	.010-.020
Ring Clearance in groove-----	.0015-.0030

OIL RINGS	
Material-----	Cast iron
Type-----	Wide slot with expander
Width-----	.1860-.1865
Wall thickness:	
235.5 Thriftmaster-----	.134-.141
235.5 Loadmaster and 261 Jobmaster-----	.115-.125
Gap clearance:	
235.5 Thriftmaster-----	.005-.015
235.5 Loadmaster and Jobmaster-----	.010-.018
Ring clearance in groove-----	.0015-.0030
Expander type:	
235.5 Thriftmaster-----	Eight crimp flat spring steel
235.5 Loadmaster and 261 Jobmaster-----	Coiled spring

CONNECTING RODS	
Assembly weight: 235.5-----	1.99 lb
261-----	2.10 lb
Upper end weight: 235.5-----	.454 lb
261-----	.544 lb
Lower end weight: 235.5-----	1.53 lb
261-----	1.55 lb
Total rotating weight of connecting rods (Weight of lower end x 6): 235.5-----	9.19 lb
261-----	9.31 lb
End play-----	.005-.010
Recommended nut torque, with oiled threads-----	35 to 45 ft lb





### ENGINE COOLING SYSTEM

Method of cooling cylinder walls --- Full stroke length water jacket with water around each cylinder.

ITEM		3100	3700, 3900	3600	3800	4000	5000	6000	RPO 5000, 6000
Capacity (quarts)	Regular	16			17		18		
	RPO 256			17	18				
Radiator	Make, type & matl	Harrison, cellular, copper							
	Size	Regular			.20 x .560 x 2		.20 x .560 x 2.5		.20 x .560 x 3.0
	RPO 256			.20 x .560 x 2.5	.20 x .560 x 3.0				
Frontal area (sq. in.)	Reg & RPO 256	407							
Pressure, cooling system		Radiator cap pressure valve opens 3-1/2 to 4-1/2 lb							
Radiator hose	Type	Fabric reinforced rubber hoses, with special curved design							
	Location and size	Inlet	Elbow type, cylinder head to radiator, 1-1/4 ID						1-1/2 ID
Thermostat	Outlet	Compound curved, coil spring reinforced, rad to water pump, 1-1/2 ID							1-3/4 ID
	Make and type	Harrison, bellows operated poppet valve							
	Location	In cylinder head water outlet							
Engine fan	Valve action	At 29" Hg Bar. press. starts to open at 148-156°F, fully open at 176°F							
	Make	Chevrolet							
	Type and size	4 staggered blades, 18 diameter							
Fan belt	Pulley size	36°V x 4-3/16 pulley dia			28°V x 4-21/64 pulley dia				
	Ratio to engine	1.405:1				1.393:1			
	Material	One-piece reinforced rubber							
	Size	3/8 x 42-1/2 approx pitch length				11/16 x 42-7/8 approx pitch length			
Water pump	Shroud				With RPO 256 rad equip			Regular	
	Type and drive	Centrifugal, by fan belt							
	Location	On front of cylinder and case							
	Capacity (GPM @ Engine RPM)	47 @ 4000							54 @ 4000
Bearing	Anti-friction bearings, see page 172								
Seal	Molded rubber, spring loaded								

### FUEL SYSTEM

#### FUEL TANK

ITEM		3100 3600	3800	4100, 4400 6100, 6400	5000	3700 3900	45, 67 6800	
Location	Chassis and single unit bodies	Inside of frame on right side	Outside of frame on RH side	Outside of frame on RH side				
	Models with cab	Behind seat in cab, equipped with fuel line shutoff and drain cock						
Type of construction		Two stamped pans, seam welded together				3 pc. seam weld		
Capacity	Cabs	17-1/2						
	Others	16	18			16	30	
Filler location		On right side of vehicle						
Gauge (tank)	Make	AC						
	Type	Electric						

\*-BB1-871-5B 37-3900; BB2-20755, 5000

#### CARBURETOR

ITEM		31, 36-3800 4000, 6000	RPO 6000	37-3900, 5000 Reg & RPO
Make		Rochester		Carter
Model		7004468	7005140	*
Type		Single adjustment, balanced		
		Down draft		Up draft
Idle adj (number of turns open)		1 to 2-1/2		1/2 to 1-1/2
Size (main venturi throat ID)		1-11/32	1-15/32	1-3/16
SAE flange size		1-1/2		
Float level when closed		Bottom of float is 1-5/16 below finished surface of cover		Top of float 0 to 1/32 below top of float chamber
Choke		Manual (no automatic choke)		
Manifold Cover	Heat control	Automatic (thermostatic)		
		None		

### AIR CLEANER

ITEM		3100, 3600, 3800, 4000	3700, 3900	5000	6000
Make		AC			
Silencer & flame arrester type; oil-wetted		Regular equipment			
Heavy duty	1 pint oil capacity	RPO 216		Regular	
Oil bath type	2 pint oil capacity	RPO 216		Regular	

Continued

### FUEL SYSTEM—Continued

#### OCTANE SELECTOR

Type ----- On distributor assy, manual, 20° range

Pressure at carburetor ----- 3-1/2 to 4-1/2 PSI

#### FUEL PUMP

Make and model ----- AC, model AF  
 Type ----- Mechanical (diaphragm) "high reserve"  
 Drive ----- From camshaft  
 Arm movement ----- 1/4 at camshaft  
 Air dome ----- Yes (inlet and outlet)  
 Filter ----- 120-mesh screen in dome

#### FUEL AND VACUUM PUMP-RPO 340

Make and model ----- AC, model DB  
 Pressure at carburetor ----- 3-1/2 to 4-1/2 PSI  
 Other fuel pump specifications -----  
 ----- See regular fuel pump  
 Vacuum pump type ----- Mechanical (diaphragm)  
 Operation ----- Operative when manifold vacuum is insufficient for windshield wiper action.

### EXHAUST SYSTEM

#### Muffler:

Make and type ----- Various makes; diffusion and resonance type with straight through flow

Muffler mounting ----- Single-point

Exhaust pipe outside diameter ----- 2

Tail pipe inside diameter ----- 1-13/16

### ENGINE LUBRICATING SYSTEM

#### METHOD OF LUBRICATION

Type ----- Full pressure (direct and metered pressure)  
 Main bearings ----- Direct pressure through drilled passages in cylinder case  
 Camshaft bearings ----- Direct pressure through passages from main bearings  
 Timing gears ----- Sprayed by nozzle which is fed oil from the camshaft front bearing  
 Connecting rod bearings ----- Direct pressure from main bearings through drilled passages in crankshaft  
 Cylinder bores and piston pins ----- Sprayed from metering hole in each connecting rod bearing  
 Valve mechanism ----- Oil flows from rear camshaft bearing through drilled passage to push rod chamber through metering hole in pipe fitting, then is piped to rocker shaft and arms. Valve stems, springs, and push rods are gravity-fed from rocker arms.

Width of gears ----- 1 inch

Cleaner type ----- 20 mesh, .015 non-corrosive steel wire screen, with by-pass

#### MISCELLANEOUS

Oil level gauge ----- Rod type

Oil Filter (RPO 237)		
Make and Model	Capacity (dry)	Replaceable element Model No.
AC S-6	1 qt	P-115
AC S-2	2 qt	P-117

#### OIL PAN

Capacity (quarts) ----- Dry, 5-1/2; refill, 5

Drail plug location ----- At rear of oil pan

Torque, corner bolts ----- 12-1/2 to 15 ft lb

Torque, flange screws ----- 6 to 7-1/2 ft lb

#### OIL PUMP

Type ----- Spur gear  
 Drive ----- From camshaft by worm gear  
 Capacity (gallons per minute, hot oil) -----  
 ----- 4.30 at 1170-1200 engine RPM  
 Normal oil pressure (hot) -----  
 ----- 45 PSI at 1170-1200 engine RPM

#### LUBRICANT RECOMMENDED

Temperature, ambient ----- Grade

Not lower than 32°F ----- SAE 20W or SAE 20

As low as 10°F ----- SAE 20W

As low as minus 10°F ----- SAE 10W

Below minus 10°F ----- SAE 5W

Above 90 F ----- SAE 30

### CRANKCASE VENTILATION AND OIL FILLER

Crankcase ventilation: ----- Forward control and 261 engine models ----- Vacuum operated.  
 Closed outlet tube from ventilator body to inlet manifold provides suction when engine is running  
 All others ----- Open outlet tube, extending from ventilator body into air stream beneath

engine, provides suction when vehicle is moving.

Air Inlet (261 Engine) -----

Through air cleaner to rocker cover. All others, Inlet louvers in rocker cover.

Oil filler location (Series 5000) In ventilator body;

All others, on valve rocker cover at front.

## ENGINE ELECTRICAL SYSTEM

### GENERATOR

Series usage		3000	4-5-6000
Make		Delco-Remy	
Model number		1100028	1102793
Rated voltage		6 to 8	
Ventilation		By fan in generator pulley	
Driven by		Fan belt	
Pulley size	V angle	36°	28°
	Pitch dia	2.875	3.434
Speed ratio (generator to engine)		2.05:1	1.83:1
Max. output speeds (hot)	Gen. RPM	3000 and up	2550 and up
	Eng. RPM	1462 and up	1393 and up
Bearings:			
		Commutator end	Drive end
Number-----		812823	
Type-----		Bronze bushing	Anti-friction bearing
ID-----		.562-.563	See pages
OD-----		.778-.780	171, 172
Length-----		.792-.807	
Brush spring tension-----		24 to 32 oz	
Rotation (drive end)-----		Clockwise	

### VOLTAGE AND CURRENT REGULATOR

Series usage		3000	4-5-6000
Make		Delco-Remy	
Model		1118843	1118827
Type		Vibrator	
Location		In engine compartment on LH side of dash	
Voltage regulator	Volts	7.4	
	Temp	Operating	
	Average air gap	.075	
Current regulator	Amp	40	45
	Temp	Operating	
	Average air gap	.075	
Cut-out relay	Point opening (amp)	0-4	
	Point closing (volts)	6.4	
Generator armature speed (RPM)		1050	1160
Average air and point gap		.020	

### RPO 326 HEAVY DUTY GENERATOR EQUIPMENT

Make	40 amp	45 amp	50 amp	55 amp
Delco-Remy	3-4000, 5-6000	3000	All	All except 37-39-5000
Gen No.	1105009	1102793	1105008	1106757 or 1106976
Reg. No.	1118831	1118827	1118835	1118833 or 1118842

### STARTING

Starting device----- Mechanical over-running clutch actuated by push button and solenoid for Series 3700, 3900 and automatic transmission. All others by foot pedal.

Starting operation----- With ignition switch ON, depress push button on Series 3700, 3900, and automatic transmission; depress starter for all others.

Pinion meshes----- From front of flywheel

Pinion teeth----- 9

Flywheel teeth----- 139, 1/2 wide, 13.9 PD

Flywheel bolt torque----- 50-65 ft lb

Gear ratio (starter to flywheel)----- 15.44:1

Normal engine cranking RPM (60°F air)----- 125

### STARTING MOTOR

Make----- Delco-Remy

Model: Series 3700, 3900----- 1107109

Automatic transmission----- 1107135

All others----- 1107108

Number of field coils----- 2

Direction of rotation (front view)--- Counter-clockwise

Bushings	Commutator end	Drive end
Type	Oilless, rolled bronze, with graphite-filled indentations on inside surface.	
ID	.5625-.5635	.499-.501
OD	.6245-.6255	.5615-.5625
Length	.812	.781

Test data:

Amperage----- 550----- 80

Volts----- 3.25----- 5.60

Torque----- 11 ft lb-----

RPM----- 5500-----

Brush spring tension----- 24 to 28 oz

### BATTERY

ITEM	4500, 6700 6800	3700 3900	ALL OTHERS
Make and model	Delco, 19Q6W	Delco, 15AA6-W	
SAE No.	2M	1M	
Length, at top	10-5/16	9-1/32	
Width, at top	7		
Height (overall)	8-11/16		
Voltage	6		
Capacity	125 amp hrs	100 amp hrs	
	at 20-hour rate		
Bench normal charging rate	9 amp	7 amp	
Cells	3, side-to-side arrangement		
Plates per cell	19	15	
Ground	Negative terminal		
Location	At right side of engine, on frame	In cab, below floor, at right of driver	

### IGNITION SYSTEM

Type----- Separate units, high tension distributor with centrifugal and vacuum spark advance, high intensity spark and water-proof ignition coil.

Ignition cable: Make----- Packard Electric

Ignition lock: Make----- Delco-Remy

Type----- Two-position on and off, key is removed in off position only.

### COIL

Make, model (5000 only)----- Delco-Remy 1115388

All others----- Delco-Remy 1115380

Location----- Engine right side

Amperes drawn----- 4.5 engine stopped; 2.5 idling

### SPARK PLUGS

Make and model:

Thriftmaster----- AC, 44-5 Com.

Loadmaster & Jobmaster----- AC, 43-5 Com.

Thread size----- 14 mm

Recommended gap----- .035

Recommended torque----- 15-25 ft lb

Continued

## ENGINE ELECTRICAL SYSTEM—Continued

### DISTRIBUTOR

Distributor (Delco-Remy)	1112396	1112592
Engine cu in. displacement	235.5	261
Breaker contact lever opening	.016-.021	
Nominal cam angle	38°-45°	
Breaker arm tension	19-23 oz	
Vacuum control part no.	1116043	
Condenser Part number	1869704	
Capacity	.2 mf	

### VALVE TIMING (theoretical) 235.5 ENGINES

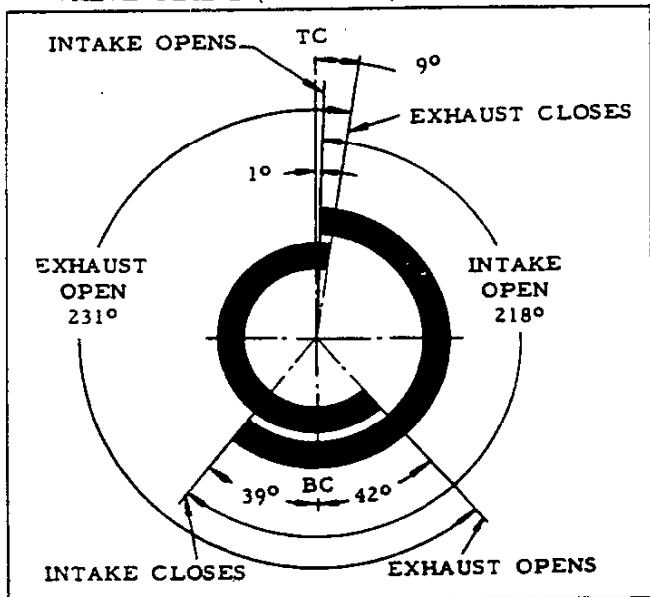

### VALVE TIMING (theoretical) 261 ENGINE

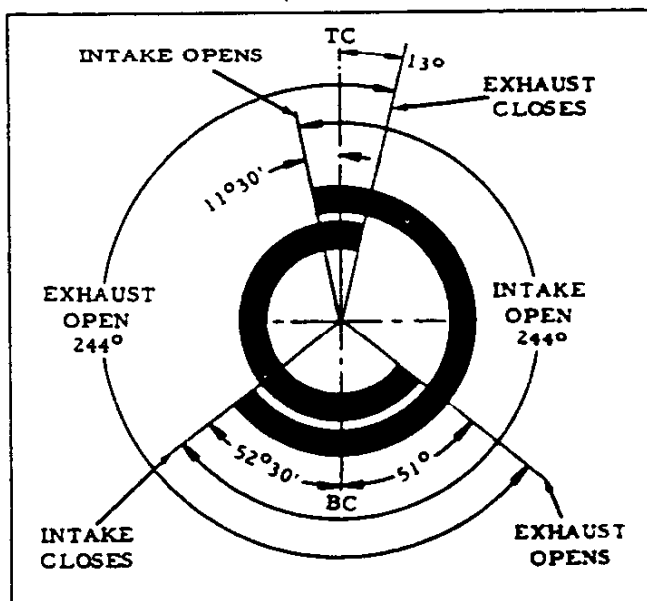

### ENGINE TIMING-IGNITION

(Ignition data given in crankshaft degrees)

Timing spark advance (initial setting):

235.5 Engine ..... 2° after TC  
 261 Engine ..... 5° before TC  
 Timing mark, location ..... Steel ball in flywheel  
 Firing order ..... 1-5-3-6-2-4  
 10-29-54.

**160—ENGINE**

### THRIFTMASTER & LOADMASTER 235.5 CU IN. ENGINES

Automatic Spark advance	Advance begins	Full advance
Vacuum Control	7" to 8.5" Hg	18° to 22° at 16.5" to 18.5" Hg
Centrifugal	450 to 750 RPM	24° to 28° at 3500 RPM and up

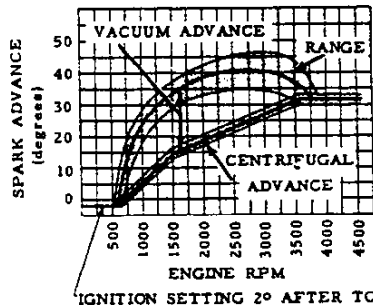

### JOBMASTER 261 CU IN. ENGINE

Automatic Spark advance	Advance begins	Full advance
Vacuum Control	7" to 8.5" Hg	18° to 22° at 16.5" to 18.5" Hg
Centrifugal	500 to 600 RPM	32° to 36° at 3600 RPM and up

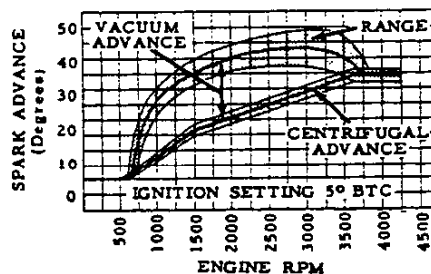

### ALL TRUCKS

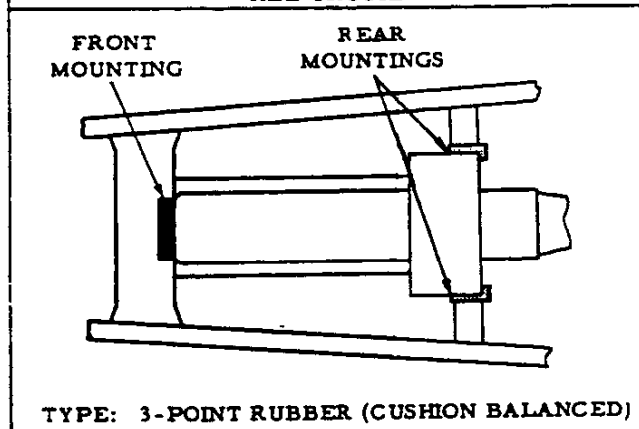

**CHEVROLET 1955 SPECIFICATIONS—TRUCK**

## CLUTCH

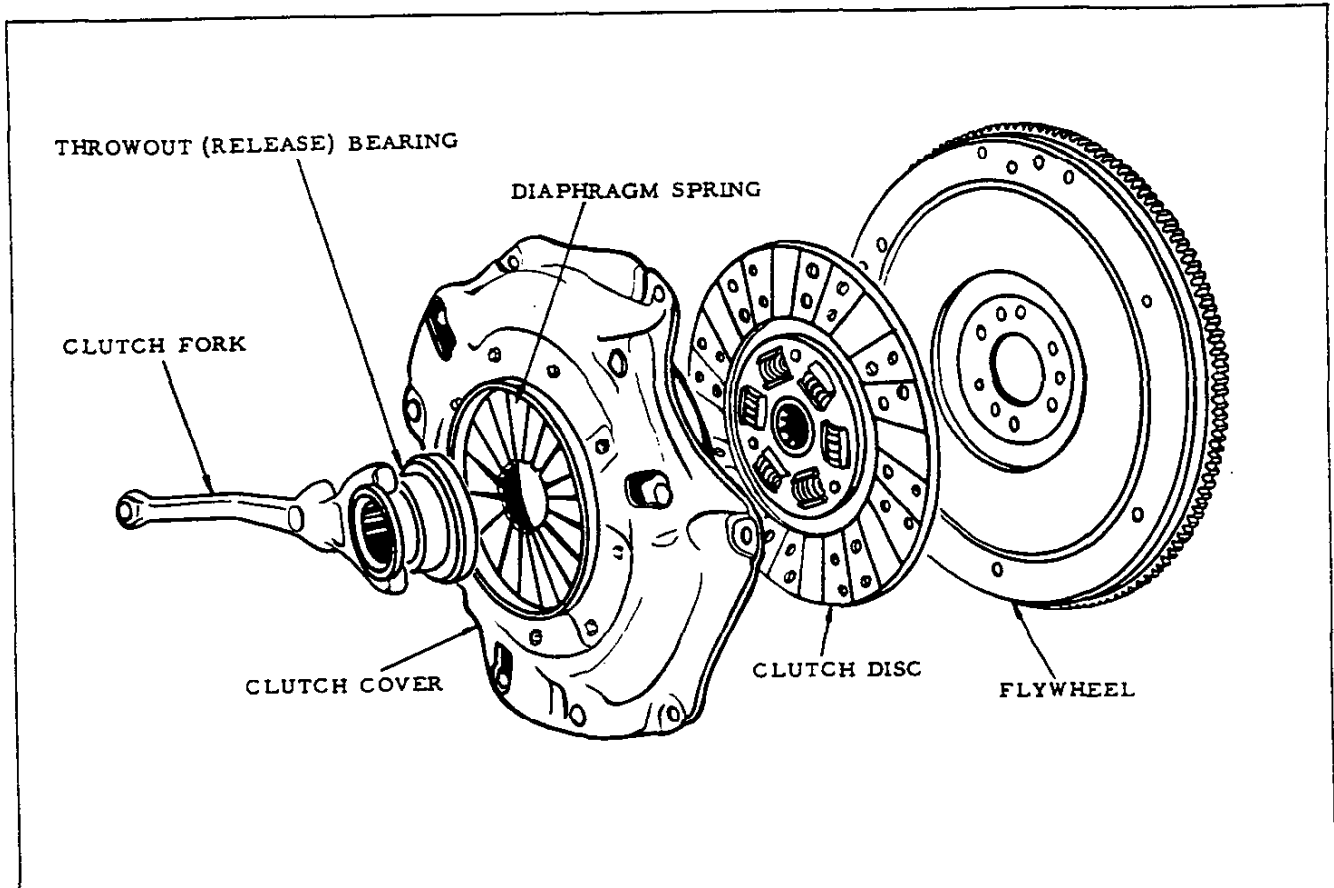

ITEM		3100-3600-3800		All others	
		Regular clutch	RPO 227	Regular clutch	
Type		Single dry plate			
Rated torque capacity		238 ft lb	282 ft lb		
Drive		Direct to flywheel			
Ventilation		Vaness cast in pressure plate			
Diaphragm spring	Pressure in flat position	1325 to 1450 pounds	1450 to 1550 pounds		
	Material	Spring steel, heat treated			
	Pressure levers	18, integral with spring			
Driving members		Two (flywheel and pressure plate)			
Driven disc	Type	One, spring cushioned plate with two molded facings			
	Vibration insulation at hub	6 cushion springs			
	Facing (2)	Material	Woven or molded asbestos composition		
		Outside diameter	10	11	
		Inside diameter	6	6-1/2	
		Area (both facings)	100.53 sq. in.	123.70 sq. in.	
Thickness		.132-.138	.130-.136		
Bearings	Throwout (release)	Type, make, number	Anti-friction bearings, see pages 171, 172		
		Lubrication	Packed for life		
	Pilot	Make and number	Chevrolet 412562		
		Type	Sintered graphite-bronze bushing, Oil-impregnated		
		Inside diameter	.5905-.5920		
		Outside diameter	1.0935-1.0945		
		Width	.740-.760		
		Lubrication	Self		
Controls	Clutch fork type	Drop-forged (pivot mounted on ball)			
	Pedal mounting location	On shaft, bracketed to side rail (to sub frame in 5000)			
Flywheel	Material	Cast alloy iron			
	Weight (with ring gear)	30 pounds			
	Ring gear type	Steel, shrunk on			
	Ring gear teeth	139, 1/2 wide, 13.9 P. D. (9 teeth on starter pinion)			
Clutch attachment to flywheel		6 Bolts			

## TRANSMISSION

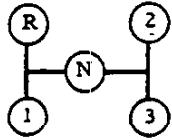

3 SPEED  
SHIFTING PATTERN

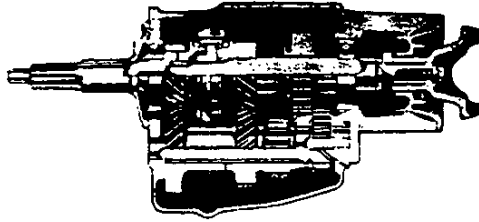

3-SPEED TRANSMISSION  
(HEAVY DUTY)

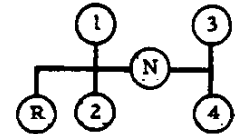

4 SPEED  
SHIFTING PATTERN

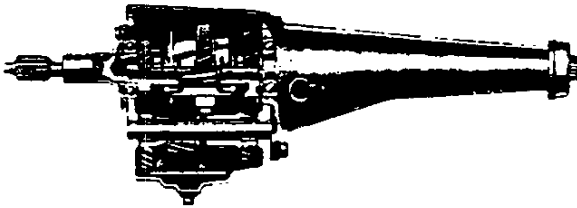

3-SPEED TRANSMISSION  
(CONVENTIONAL)

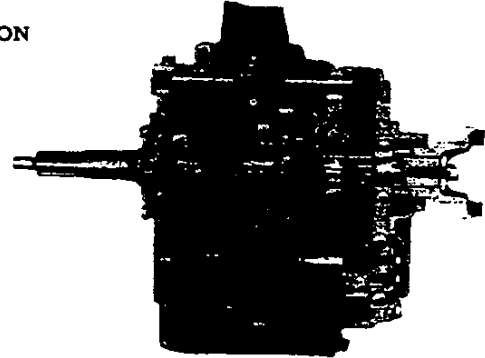

4-SPEED TRANSMISSION

ITEM		3100, 3600, 3700	3100, 3600, 3700 3800, 3900, RPO	3800, 3900, 4000 5000, 6000 Reg 3100, 3600, 3700 RPO
Make and type		Own, 3-speed Synchro-mesh	Borg-Warner, 3-speed Synchro-mesh, heavy duty	Own, 4-speed Synchro-mesh
Gear shift control	Type	Manual, remote		
	Location	Mounted on steering column		
Input torque capacity		220 foot pounds	230 foot pounds	220 foot pounds
Gears	Type	All helical	Helical, except 1st and reverse	
	Material	Forged steel, hardened		
Synchronized speeds		2nd and 3rd		2nd, 3rd, and 4th
Constant mesh speeds		2nd		2nd and 3rd
Sliding gears		1st and reverse		
Ratios	Forward	1st	2.94:1	3.17:1
		2nd	1.68:1	1.75:1
		3rd	Direct	Direct
		4th		
	Reverse	2.94:1	3.76:1	6.78:1
Bushings	Reverse idler material		Bronze, ball indented	
	Size	I D	.7515-.7525	.875
		Length	3/4	1.062
	Transmission rear bearing support material		Bronze, ball indented	
Size	I D	1.504-1.506		
	Length	1.00		
2nd gear bearing	Material		Bronze, ball indented	Bronze, ball indented
	Size	I D	1.3775-1.378	1.8152-1.8162
		Length	1-13/16	1.889-1.899
3rd gear bearing	Material		Nickel phosphor bronze	
	Size	I D		1.6248-1.6255
		Length		
Lubricant capacity		1-1/2 pints	2-3/4 pints	6 pints
Power take-off provision	Type of opening			6 bolt SAE
	Location			Left side of transmission
	Drive gear	Type		Helical
		No. of teeth		33 teeth
	Speed			425 RPM at 1000 eng RPM
Anti-friction bearings		See pages 171, 172		

10-29-54 \* - Gear I. D. Anti-friction coated  
162 - TRANSMISSION

CHEVROLET 1955 SPECIFICATIONS—TRUCK





## STEERING GEAR

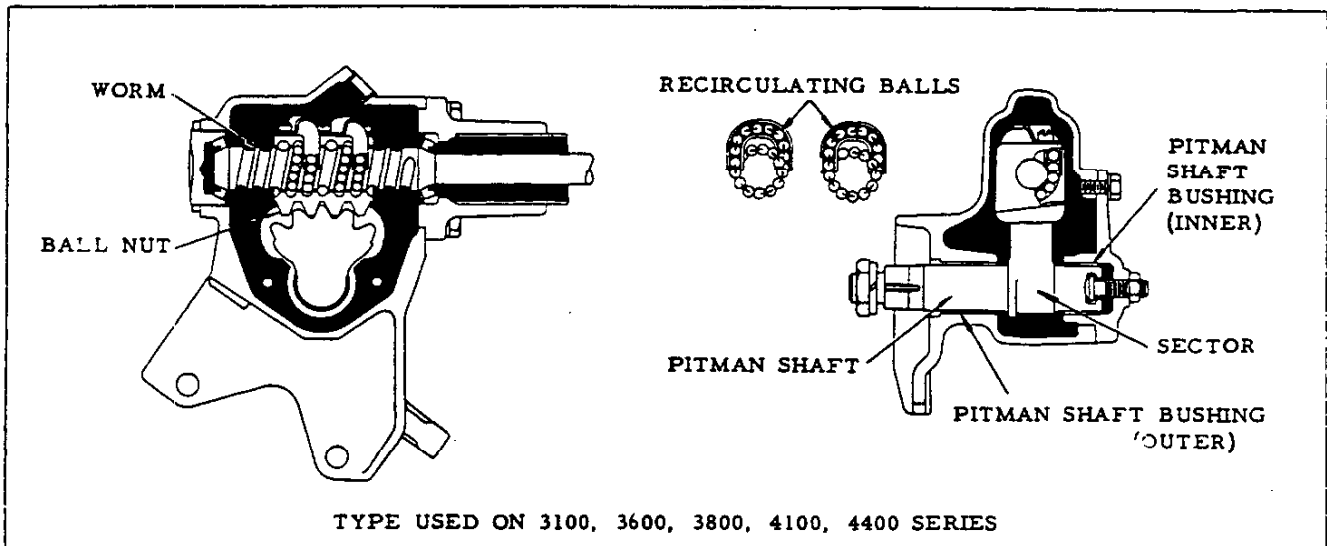

ITEM		3100, 3600, 3800, 4100, 4400	3700 3900	4500, 5000, 6000
Type		Semi-reversible		
Ratio		26.24:1	19.8:1	27.76:1
Mounting		On frame side member		
Pitman shaft bushings	Material		Cast bronze	
	Outer	Inside dia	1-1/8	1-1/4
		Length	1-3/8	1
	Inner	Inside dia	1-1/8	
Length		27/32		
Pitman shaft	Diameter	Outer end	1-1/8	1-1/4
		Inner end	1-1/8	
	Location	Below worm		
Pitman arm type		One-piece, drop forged steel		
Main shaft diameter		3/4		13/16
Column outside diameter		1-3/4		
Horn cable and contact		The cable lead is attached to a contact ring imbedded in rubber, inside upper end of steering column		
Steering wheel	Type		3-Spoke	
	Material		Hard rubber vulcanized to steel insert	
	Diameter		18	
Anti-friction bearings		See pages 171, 172		

### TURNING DIAMETERS

Series	Wheelbase	A (feet)		B (feet)	
		MAX	MIN	MAX	MIN
3100	116	41	39-1/4	43-1/2	41-3/4
3600	125-1/4	50	47-1/2	52-1/2	50
3700		43-1/4	41-1/2	46-3/4	45
3800	137	54	51-1/4	56-1/2	53-3/4
3900		46-1/2	44-1/2	49	47
4100	161	49-3/4	47-1/2	52-1/4	50
4400		57-1/4	54-1/2	60-3/4	58
4500	110	57-1/4	54-1/2	60-3/4	58
5100		41-3/4	40	45-1/4	43-1/2
5400	134	49	47	52-1/2	50-1/2
5700	158	56-1/2	53-3/4	60	57-1/4
6100	137	49-3/4	47-1/2	53-1/4	51
6400	161	57-1/4	54-1/2	60-3/4	58
6500	179	62-1/2	59-3/4	66	63-1/4
6700	199	68-3/4	65-1/2	72-1/4	69
6800	212	72-3/4	69-1/4	76-1/4	72-3/4

**TIRES—TUBES—WHEELS**

Tire Size and Ply Rating	Base or RPO *	Models	Number of Tires	Tire and Rim Association Standards						Wheels							
				Loaded		Maximum Recommended		Tube Section	Valve	Flap	Rim Size	Off-set	Attach-ment				
				Radius Rolled	Rev Per Mile	Capa-city	Press PSI										
6.00-16-6Ø	Base	3100	Five b	13.7	735	1065	36	6.00	15	None used	16 x 4-1/2 K	9/16	Six 7/16-20 bolts, 5-1/2 circle				
6.50-16-6Ø	282			13.9	728	1215	36	6.50			16 x 5 K	7/16					
15-6	273			14.1	715	1500	40	7.00	150 SB90°	15L	15x 5.50F	0					
15-8	280	3600 3700	Four	1670	48	7.00	16L	16x 5.50F		4-9/16	Eight 1/2-20 bolts, 6-1/2 circle						
6.50-16-6 Ø	282	3600	Six dual	13.9	728	1215	36	6.50	76 SB	17M		17x 5.0	7/16				
7.00-17-6	277	3600 3700	Four	15.4	655	1575	45	7.00W									
7.00-17-8	278			1775	55	7.50W											
7.50-17-8	272	3800 Y 3900	Four	15.4	655	1575	45	7.00W									
7.00-17-6	278			1775	55	7.50W											
7.00-17-8	272			637	2100	60	7.50W										
7.50-17-8	272			640	2395	75	7.50W										
7.50-17-10	329	3802	Six dual	16.0	630	1850	55	7.00W						76-90° E-12	20K	17x 5.0	4-9/16
7.00-18-8	295	3802-03-08 09-12, 3900		16.5	608	1700	50	6.50W									
6.50-20-6	Base	4000		Six dual	17.1	590	2000	55			7.00W						
7.00-20-8	300						2250	70	7.50W								
7.00-20-10	296				5000 (s) 6100, 6400	17.7	571	2375	60	177 SB90°	20M	20x 6.0 Ø	5-3/8				
7.50-20-8	304							2700	75								
7.50-20-10	305							2375	60								
7.50-20-10	Base							2700	75								
7.50-20-8	305				6500 (s)	18.4	551	2900	65	77-90° C-20	20N	20 x 6.5 H	5-5/8				
8.25-20-10	343				6700, 6800			3150	75								
8.25-20-12	344		5000 (s) 61-64-6500 (s)		19.3	526	3450	65	9.00W	175 90° C-20	20N	20 x 6.5 H	5-5/8				
9.00-20-10	312		6500 (s)														

\*-Base equipment includes tires of the same size and ply rating on front and rear wheels. Except for 9.00-20-10 pr tires, which are available for rear only, all tires shown for each series are available in any front and rear combination provided tires of a larger size or ply rating are not used on the front, and provided front, rear and spare wheels remain interchangeable.

b-Including spare tire. Ø-Passenger car type tires. All other tires shown are truck type.

ç-All models have a spare wheel as standard equipment except 3700, 3900.

⊕-Used with 7.00-20 tires on front wheels when 7.50-20-8 or 10 ply tires are specified for rear wheels.

Y-Base tires for 3800 are 7.00-17-6pr front and 7.00-17-8pr rear.

H-20 x 6.5 rims are available as RPO 291, mandatory with 9.00-20 tires, optional with 8.25-20 tires.

**WHEEL AND HUB CAP APPEARANCE**

STRIPING COLOR  
3 STRIPES  
DELUXE WHEEL ONLY

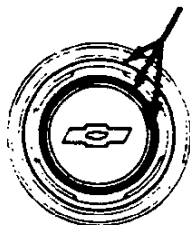

6.00-16 REG  
3100

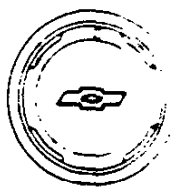

15 INCH  
3600, 3700 REG  
3100 RPO



6.50-16  
3600 RPO DUAL

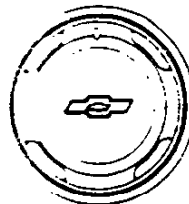

17 INCH  
3800, 3900 REG  
3600, 3700 RPO

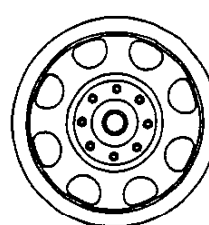

18 INCH  
3800, 3900  
RPO DUAL

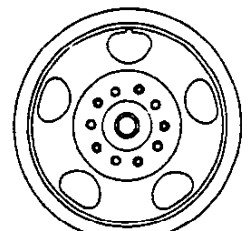

20 INCH REG  
4000, 5000, 6000  
Single or dual

10-29-54

### LOAD CAPACITY CHART

GROSS VEHICLE WEIGHT FOR 1955 CHEVROLET TRUCKS AND SCHOOL BUSES

TYPE	MODEL			NOMINAL RATING	GROSS VEHICLE WEIGHT	MINIMUM TIRES AND EQUIPMENT		EQUIPMENT
	SERIES	WHEEL BASE	TIRE SIZE AND PLY RATING			FRONT	REAR	
SEDAN DELIVERY	1508	D55	115		\$4000	6.70-15-4	6.70-15-4	
					4100	6.70-15-6	6.70-15-6	
LIGHT DUTY	3100	H55	116	1/2 Ton	\$4200	6.00-16-6	6.00-16-6	
					*4800	6.00-16-6	6.50-16-6	10-leaf rear spring
MEDIUM DUTY	3600	J55	125-1/4	3/4 Ton	\$5400	15-6	15-6	
					5800	15-6	15-8	
						7.00-17-6	7.00-17-8	
					*6900	6.50-16-6	6.50-16-6 Dual	2-stage, 8-leaf rear spring
						7.00-17-6	7.50-17-8	
					\$6200	15-6	15-6	
	3742	K55	125-1/4	3/4 Ton	6600	7.00-17-6	7.00-17-6	
						15-6	15-8	
					*7000	7.00-17-6	7.00-17-8	
	3800	L55	137	1 Ton	\$6200	7.00-17-6	7.00-17-8	
					7000	7.00-17-6	7.50-17-8	
					*8800	7.00-18-8	7.00-18-8 Dual	2-stage, 8-leaf rear spring and auxiliary
3942	M55	137	1 Ton	\$6700	7.00-17-6	7.00-17-6		
				7100	7.00-17-6	7.00-17-8	Double acting rear shock absorbers	
				7500	7.00-17-6	7.50-17-8	Above plus stabilizer	
				*10000	7.00-18-8	7.00-18-8 Dual	Above plus 2-stage, 8-leaf rear spring and auxiliary	
HEAVY DUTY	4100	N55	137	1-1/2 Ton	\$10000	6.50-20-6	6.50-20-6 Dual	
					11000	6.50-20-6	7.00-20-8 Dual	
	4400	P55	161		12500	6.50-20-6	7.00-20-10 Dual	11-leaf rear spring & aux.; hydrovac; and on 4100, heavy duty frame
					*14000	7.00-20-8	7.50-20-8 Dual	Above plus 8-leaf front spring
	5100S	SS55	110	1-1/2 Ton Special	\$14000	7.50-20-8	7.50-20-8 Dual	
	5400S	ST55	134		14000	7.50-20-8	7.50-20-10 Dual	
	5700S	SU55	158					
	6100S	SV55	137	2 Ton	*15000	7.50-20-8	8.25-20-10 Dual	
	6400S	SW55	161					
	6500S	SX55	179					
	5100	S55	110		\$14000	7.50-20-8	7.50-20-8 Dual	
	5400	T55	134		14000	7.50-20-8	7.50-20-10 Dual	
	5700	U55	158					
	6100	V55	137		*16000	7.50-20-8	8.25-20-10 Dual	
6400	W55	161						
6500	X55	179						
SCHOOL BUS CHASSIS	3802 Plus RPO 329	L55	137	16 Pupils	*\$7600	7.50-17-8	7.50-17-10	9-leaf rear spring
				30 Pupils	\$10500	6.50-20-6	6.50-20-6 Dual	
	4502	R55	161	36 Pupils	*12000	6.50-20-6	7.00-20-8 Dual	
				42 Pupils	\$13500	7.50-20-8	7.50-20-8 Dual	
	6702	Y55	199	48 Pupils	*16000	7.50-20-8	8.25-20-10 Dual	
				48 Pupils	\$13500	7.50-20-8	7.50-20-8 Dual	
6802	Z55	212	54 Pupils	*16500	7.50-20-8	8.25-20-10 Dual		

\*-A plate is supplied with each vehicle showing chassis number and maximum Gross Vehicle Weight (GVW). The maximum GVW rating includes the truck chassis with lubricants, water and full tank or tanks of fuel, plus the weight of the cab or driver's compartment, body and special chassis and body equipment, and payload. These GVW ratings are reduced per above table when tires and/or equipment of lesser capacity are used. Series D-55 plate shows no GVW. †-Base GVW, tires shown included in base price. Extra ply rating and/or oversize tires and equipment are available with no increase in gross vehicle weight rating.

State of Michigan  
County of Oakland

On this 17th day of September, 1954, personally appeared before me, R. S. Flexico, known to me as such who makes oath that the data on this sheet are true as represented.

*Ed Woodward*  
My commission expires July 28, 1957  
Acting in Wayne County Michigan

September 17, 1954  
The data on this sheet are true as represented.  
CHEVROLET - CENTRAL OFFICE  
ENGINEERING DEPARTMENT  
DIVISION OF GENERAL MOTORS CORPORATION

*R. S. Flexico*  
R. S. Flexico  
Asst. Chief Engineer  
Truck Chassis

## BUMPERS

CURVED TYPE			CHANNEL TYPE		
			CHANNEL TYPE		CURVED TYPE
ITEM	3100, 3600	3105-06-07-16	3800	3805-3807	4000, 5000, 6000 Reg 3700, 3900 RPO
Location	Front	Rear	Front	Rear	Front
Type					Channel
Overall width					75-1/16
Overall height					6-3/4
Gauge	.133-.147			.231-.245	.217-.245
Material	Spring steel				HR Steel
Finish	Painted				

## LIGHTS AND HORN

(Units listed below are shipped loose on Series 3700 and 3900)

### HEADLIGHTS

Make and type ----- Guide, Sealed Beam  
 Location ----- In front fender faces  
 Sealed Beam unit: Diameter ----- 7  
 Lens diameter ----- 6-11/16  
 Dimmed by ----- Foot switch (depresses beam)  
 Beam indicator location ----- In speedometer face

### LIGHTING SWITCHES

Make ----- Delco-Remy  
 Main Switch ----- Two-position, mounted on instrument panel. Incorporates a rheostat, operated by rotating the switch knob, which controls the brightness of the instrument panel lights.  
 Stop light switch ----- Mechanical, on toe board  
 Dome light switch ----- At light

### PARKING LIGHTS

Location ----- Between center and lower grill bars at outer corners of radiator grille

### TAIL AND STOP LIGHTS

Make and type ----- Guide, combination  
 Number and location:  
 Two-unit bodies ----- One, attached to rear end of frame left side member. Canopy Express and Suburban Carryall with tail gate -- One, centered on tail gate (linkage automatically adjusts light for tail gate position). Panels and Suburban Carryall with Panel type rear doors. Panels ----- One, on left rear door RPO 249:  
 Panel, Canopy Express, and Suburban Carryall ----- Two extra combination tail and stop lights, one at rear of each body side panel.  
 Rear license plate ----- Illuminated through window in combination tail and stop light.  
 Dome light ----- In all except cowl models

### PROTECTIVE DEVICES

Circuit breaker: ----- Type Bi-metal thermal element in main lighting switch  
 Operation ----- Closed 30 amps; open 42 amps  
 Fuses (in series with circuit breaker, in tail and stop light circuits); Number and type -- 2 and 1 spare; 20 amp, AGC glass cartridge  
 Location ----- In fuse box on left front of dash

### HORN

Make and type ----- Delco-Remy;  
 ----- vibrator, low-note  
 Location ----- Bolted to radiator support  
 Current drain ----- 19-21 amperes

### BULBS

USED IN	QUANTITY	TRADE NO.	POWER		USED IN	QUANTITY	TRADE NO.	POWER
Parking lights	2	63	3cp	Tail and stop lights	3107, 3116 Tail	1	63	3cp
Instrument cluster	4	55	2cp		and 3807 Stop	1	1129	21cp
Beam indicator	1	51	1cp		All Tail	1	1154*	3cp
Ignition lock	1	51	1cp		others Stop			21cp
Dome light	1	87	15cp		RPO Tail			3cp
Head lights	2	193195¢	45W		RPO 249 Stop	2	21cp	
Upper beam lights			35W		*-Single bulb, double filament			
Lower beam lights								

¢-GM part number

10-29-54

### INSTRUMENTS

Make ----- AC Oil gauge ----- Pressure  
 Type: Fuel gauge ----- Electric Cooling system heat indicator ----- Pressure  
 Ammeter ----- Electric Speedometer -----  
 -----Dial, driven by flexible shaft from transmission

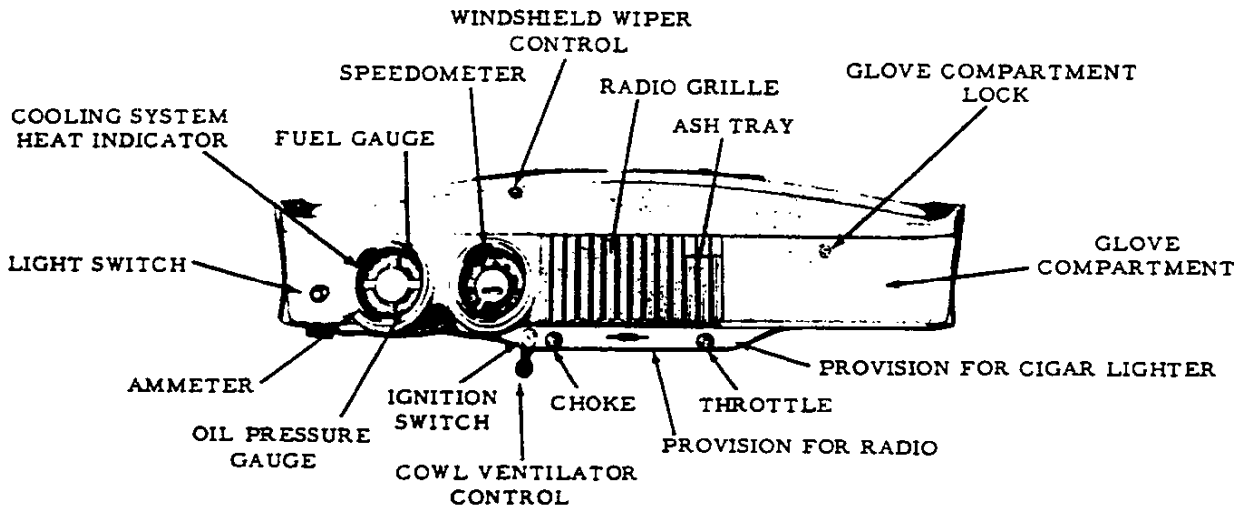

### SPEEDOMETER GEARS \*

ITEM	3100		3600			3700			3800, 3900			4000		5000, 6000	
3-speed trans	Regular		Reg		Reg	Reg									
3-speed H. D.	RPO 316		RPO 316			RPO 316				RPO 316					
4-speed trans	RPO 318		RPO 318			RPO 318			Regular						
4-speed Auto. trans		RPO 314		RPO 314			RPO 314				RPO 314				
Rear axle	Regular		Regular	RPO 208			Regular			Regular			RPO 204	Reg	RPO 201-202
Teeth	Drive	7	8	6	4	5	6	4	5	4	6	5	4		
	Driven	20	23	19	13	15	16	19	15	18	13	19	17	13	15
Pitch	Drive	30	33	30	22	26	30	22	26	22	30	26	22		
	Driven				22.4			22.4	26	22.4		26	22.4	22.4	

\*-For base tire equipment only

†-Speedometer adapter mounted at back of speedometer and controlled by two-speed axle shift lever has ratios of 1:1 and 1:750. used in combination with regular speedometer gears.

‡-Speedometer adapter 1580273 used in combination with regular speedometer gears, when RPO 208 is specified.

### SPEEDOMETER GEAR ADAPTERS

The following speedometer gear adapters are available through the Service Department for correction of speedometer and odometer errors that sometimes occur when combinations of tires, transmission, and rear axle, other than standard, are specified.

Service Package Number	1565812	1565814	1580273
Gear ratio	17:16	16:17	15:17

### TOOLS

ITEM	3100	3600, 3700	3800, 3900	4000, 5000, 6000
Jack	Capacity (pounds)	2500	3000	8250
	Raised height	15-1/8	16	18-1/8
	Lowered height	6-1/2	7-1/4	9
Jack handle				Use tire changing iron
Tire changing iron	With RPO 273			All
Wrench				

10-29-54.

## ACCESSORIES

Definition: Items made available at extra Cost through the Parts and Accessories Department and installed by the customer or his dealer.

ITEM	DESCRIPTION	MODELS
Antenna	Radio, rod type (cowl mounting)	All
Arm rest	Brown, for RH or LH door	All cabs or single unit bodies except 3106-16
Cap	Gas tank filler, locking	All
Caps	Hub, stainless steel, 16-inch	3100 only
Clock	Handwind -- with instrument panel housing	All except flat face cowl chassis models
Condenser	Radiator overflow	3100, 3600, 3800, 4000, 6000
Cover seat	Saran plastic, multi-color plaid Woven paper matting, vertical stripes	All cab models except 5000
Deflectors	Rain (Ventshades)	All
Filter	Gasoline	3100, 3600, 3800, 4000, 6000
Filter	Water	All except 5000
Flaps	Mud	All platforms & stakes
Frame	License plate	All
Guard	Bumper for curved type face bar - (painted or plated)	3100, 3600
	Bumper for channel type face bar - (painted)	4000, 5000, 6000
	Grille, brush type - Painted	
Heater	With defroster	All
	Outside air Recirculating type	
Horn	High note (to make dual horns)	All
Injector	Static eliminator, tire Powder for	
Lamp	Fog (dual), Guide sealed beam	All with cigarette lighter
	Spot Unity, with bracket mount	
	Portable	
	Glove compartment	All
	Tail and stop, universal, RH	All except 3700, 3900
	Underhood	All except 3700, 3900, 5000
Lighter	Direction signal: Rear LH and RH, single lens Front LH and RH, single lens	All
	Cigarette	
Mat	Floor, Rectangular; Choice of five colors	All
Mirror	Rear view, outside, short arm, door mounted	
	Rear view, outside, 5' round, extendible arm	
	Rear view, outside, 5-1/2 x 7-1/2, extendible arm	
	Rear view, outside, non-glare, with bracket mount	
Ornament	Hood	All except 5000
Radio	Delco receiving set plus antenna	All except flat face cowl chassis models
Reflector	Reflex (4-inch) red	All
Shaver	Electric, AC-DC	All with cigarette lighter
Step Unit	Rear	All platform & stake models
Sunshade	Right hand	All (regular equipment on 3106-16)
Tool Kit	Bag and tools	All
Visor	Sun, outside mounted	All cabs
Washer	Windshield, foot-operated	All except 3700 & 3900

## REGULAR PRODUCTION OPTIONS

RPO	ITEM		MODELS
200	Shock absorbers	Direct double-acting	Front Series 4000, 5000, 6000
		Cam & lever dbl-acting	Rear Series 3800, 4100, 5000, 6700, 6800
			Rear Series 3900
201	Two speed rear axle (8.86-6.70 ratio)	Series 5000, 6000	
202	Two speed rear axle (8.10-6.13 ratio)		
203	Heavy duty front axle	Series 4100, 4400	
204	Rear axle, 5.43 to 1 ratio	Series 4000	
207	Long running boards and rear fenders	Models 3602-03-12; 3802-03-12	
208	Rear axle, 5.14 to 1 ratio	Series 3600	
210	Rear view mirror	Short, LH (bracket only)	All Cab Chassis, except model 3103
		Short, RH (mirror and bracket)	All Cab Chassis, Pickups, and Single Unitbody models
		Long, LH (bracket only)	Models 3103-3104; 3604, 3804
		Long, RH (mirror and bracket)	All cab models
211	Rear shock absorber shields	Series 3000, except 3900	
212	Brake Booster	Series 4000	

Continued

10-29-54.

**REGULAR PRODUCTION OPTIONS —Continued**

RPO	ITEM	MODELS
214	Prop shaft brake	Series 3802-12; 3900
216	Oil bath air cleaner	1 pint capacity
		2 pint capacity
		Series 3000, 4100, 4400
		Series 3100, 3600, 3800, 4000
217	Engine positive ventilation	All except 3700, 3900
218	Rear bumper	Models 3102-03-04-12; 3602-03-04-12; 3804
225	Heavy-duty engine	Series 4000, 5000, 6000
227	Heavy-duty clutch	Series 3100, 3600, 3800
230	Platform body	Model 3608
233	Heavy-duty frame	Series 4100
234	Solid color combinations (11)	All except Series 3700, 3900, (See page 134)
237	Oil filter	All except Series 3700, 3900
241	Engine governor	Series 31-36-3800; 41-4400; 5000; 61-64-6500
243	Two-speed rear axle 8.10-6.13 ratio	Series 4000
249	Dual tail and stop lights	All single unit body models
253	Heavy-duty front springs	Series 4100, 4400
254	Heavy duty rear spring equipment	Series 3100
255	Front springs (double wrap eye)	Models 4502, 6702, 6802
256	Heavy-duty radiator	Series 3600, 3800, 4000
263	Auxiliary seat	All Panels and Canopy Express Models
264	Unison seat	All models with Cab
267	Auxiliary rear springs	Series 3800, 3900, 4100, 4400
268	Two stage rear springs	Series 4100-4400; 5000; 61-64-6500
281	Vacuum reserve tank	Series 4000, 5000, 6000
291	20 x 6.5 wheels	Series 5000, 6000
306	Speedometer fittings	Series 3600, 3700, 3800, 3900; 4-5-6000
307	Speedometer fittings	Series 3000
314	Automatic transmission	Series 3000
316	Heavy-duty three-speed transmission	Series 3000
318	Four-speed transmission	Series 3100, 3600, 3700
320	Electric windshield wipers	All Cab Chassis, Pickups and Single Unit Body Models
326	Heavy-duty generator	Rating 40 amp
		Rating 45 amp
		Rating 50 amp
		Rating 55 amp normal & low cut-in
		All models
		Series 3000
		All Models
		All except 3700, 3900, 5000
327	Solenoid starter	Models 3802, 4102
329	School bus chassis (Junior)	Model 3802
340	Fuel and vacuum pump booster	All models
341	Side mounted wheel carrier	Model 3104
342	Side mounted wheel carrier	Models 3604 & 3804
367	Front bumper	Series 3700, 3900
384	Spare wheel carrier	Series 3700, 3900
387	Rear corner windows	All Cab models
390	Deluxe equipment	Series 4000, 5000, 6000 Cab Models & 3106-16 Carryall
393	Chrome equipment	Series 3100, 3600, 3800
395	Door lock (LH door)	
		All cab and single unit body models
399	Tinted body glass	
		All platform models
401	Stake racks	
		All platform models
402	Identification plate ("S" Series)	Series 5000, 6100, 6400, 6500
430	Deluxe equipment	Models 3103-04-05; 3603-04-08; 3805
431	Deluxe equipment	Models 3803-04-08
438	Two-tone color combinations	Models 3103-04; 3603-04-08; 3803-04-08
439	Two-tone color combinations	Models 3105, 3805
272	Tires 7.50-17-8pr	Series 3600, 3700, 3800, 3900, except 3608
273	Tires, 15-6pr	Series 3100 (3600, 3700 spare)
277	Tires, 7.00-17-6pr	Series 3600, 3700 (3900 spare)
278	Tires, 7.00-17-8pr	Series 3600, 3700, 3800, 3900
279	Tires, 7.50-17-10pr	Model 3802, spare
260	Tires, 15-8 pr	Model 3600, 3700
282	Tires, 6.50-16-6pr	Series 3100, 3600 except model 3604
295	Tires, 7.00-18-8pr	Series 3800, 3900 except models 3804-05-07
296	Tires, 7.00-20-10pr	Series 4000
300	Tires, 7.00-20-8pr	Series 4000
304	Tires, 7.50-20-8pr	Series 4000 (5000, 6000, spare)
305	Tires 7.50-20-10pr	Series 4000, 5000, 6000
312	Tires, 9.00-20-10pr	Series 5000, 6100, 6400, 6500 except 5408, 6108, 6408
343	Tires, 8.25-20-10pr	Series 5000, 6000
344	Tires, 8.25-20-12pr	Series 5000, 6000

### ANTI-FRICTION BEARINGS

BEARING FUNCTION		GM PART NUMBER	TYPE †	1500	3100	3600	3700	3800	3900	4100	4500	5100	54-5700	6500
				2100 2400						4400			61-6400	6700 6800
Front Wheel	Inner	909040	Cup-Cone	2										
		909052	Cup-Cone		2									
		909046	Cup-Cone			2	2	2	2	2				
		7450335	Taper R								2	2	2	2
	Outer	909041	Cup-Cone	2										
		909001	Cup-Cone		2									
		909045	Cup-Cone			2	2	2	2	2				
		7450336	Taper R							2	2	2	2	
King Pin Thrust		373476	SR Ball		2									
Rear axle	Pinion front	7450373	DR Ball	1	1									
		442093	Taper R			1	1	1	1					
		954237	DR Ball							1	1	1	1	1
		455270	Taper R										*-One, RPO	
	Pinion rear	7450371	Roller	1	1									
		189436	Roller			1	1	1	1					
		144553	Roller							1	1	1	1	1
		454021	Taper R										*-One, RPO	
	Differential	187434	Barrel R	2	2									
		188930	Barrel R			2	2	2	2					
		148399	Barrel R							2	2			
		7450326	Barrel R									2	2	2
		443893	Taper R										*-Two, RPO	
	Double reduction pinion shaft	Left	443922	Taper R									*-One, RPO	
Right		443917	Taper R									*-One, RPO		
Rear wheel	Inner	188930	Barrel R			2	2	2	2					
		144527	Barrel R							2	2			
		7450320	Barrel R									2	2	2
	Outer	954861	SR Ball	2										
		111121	Roller		2									
		188932	Barrel R			2	2	2	2					
		144525	Barrel R							2	2			
		7450323	Barrel R								2	2	2	
U-Joint trunnion		3707062	Needle	8	8									
		3708036	Needle			8	8	12	12	12	12	8	12	16
Prop shaft support		954257	SR Ball					1	1	1	1		1	2
Water pump		38361316	DR Ball	1										
		37041627	DR Ball	1										
		954252	DR Ball		1	1	1	1	1	1	1	1	1	1
Generator, front		954378	SR Ball	1	1	1	1	1	1	1	1	1	1	1
Clutch release		909422	Special permanently lubricated and sealed single row ball bearing											
Transmission	Clutch gear	954388	SR Ball	1	1	1	1							
		954358	SR Ball		9	9	9	1	1	1	1	1	1	1
	Main shaft	Fr	435844	Needle	1	1	1	1						
		Rr	7450247	Needle	1	1	1	1						
	pilot	7450010	Needle		9	9	9	1	1	1	1	1	1	1
		954886	SR Ball	1	1	1	1							
	Mainshaft, rear	954869	SR Ball		9	9	9	1	1	1	1	1	1	1
	Countershaft, front	435847	Needle	1	1	1	1							
		142260	Roller		9	9	9	1	1	1	1	1	1	1
	Countershaft, rear	435847	Needle	1	1	1	1							
954164		SR Ball		9	9	9	1	1	1	1	1	1	1	
Automatic transmission RPO 313	Mainshaft	954862	SR Ball	1										
	Planet Pinions	3689731	Needle	6										
Hydra-matic transmission RPO 314	Output shaft	903006	SR Ball		1	1	1	1	1					
	Planet pinions	440483	Needle		9	9	9	9	9					
	Rear band lever	440483	Needle		1	1	1	1	1					

Continued



**ANTI-FRICTION BEARINGS—Continued**

BEARING FUNCTION		GM PART NUMBER	TYPE †	1500	2100	3100	3600	3700	3800	3900	4100	4500	5100	54-5700	6500
				2400						4400				61-6400	6700
3-Speed Heavy duty transmission RPO 316 or 330	Clutch gear	954127	SR Ball			1	1	1	1	1					
	Mainshaft pilot	7450010	Needle			1	1	1	1	1					
	Mainshaft rear	954390	SR Ball			1	1	1	1	1					
		954829	SR Ball	1											
III	Countershaft front & rear	3709328	Needle			4	4	4	4	4					
Steering gear	Worm thrust	5666693	Cup-Cone	2											
		179291	Barrel R			2	2	2	2	2	2				
		270266	Barrel R									2	2	2	2
	Sector roller	266800	Recirculating Ball	54	60	60	60	60	60	60	60	100	100	100	100
	Steering column upper	5667239	\$	1											
270255		\$			1	1	1	1	1	1	1	1	1	1	
Total per base vehicle				31	33	33	33	33	37	37	37	37	32	37	42

\* - 2-Speed axle

† - One used, RPO 4-speed transmission

III - 3-Speed heavy duty transmission RPO 316

† - Quantity shown for needle type is number of sets of needles

\$ - Special insulated SR

¢ - With 6 cylinder engine

% - With 8 cylinder engine

INDEX

	PASSENGER	TRUCK	PASSENGER	TRUCK
Accessories	53	169	47	161
Air cleaner	35, 44	157	24	135
Alignment, wheel	25	136	24-25	137
Anti-friction bearings	171-172	171-172	35, 44	158
Automatic transmission	50	163	35, 44	158
Axle, front		136	35, 44	157-158
Axle, rear	27	138-139		167
Axle rear, two-speed		142		
Battery	36, 45	159	27	138-139
Bearings, anti-friction	171-172	171-172	27	138-139
Bearings, crankshaft & camshaft	32, 41	154	48-50	162
Belt, engine fan	36, 45	157	48	162
Body dimensions	12-17	64-130	36, 45	159
Body glass		23		23
Booster, brake		146		147
Brakes	27-28	146		134
Breaker points	37, 46	160		166
Bulbs, light	52	167		143
Bumpers		167		34, 43
Cab dimensions		133		156
Camber, wheel	25	136		
Camshaft	32, 41	154		
Carburetor	35, 44	157		
Caster, wheel	25	136		
Chassis dimensions		64-130		
Circuit breaker	52	167		
Clutch	47	161		
Coil, ignition	37, 46	159		
Colors, exterior	20-21	134		
Colors, interior	20-21			
Condenser, distributor		160		
Connecting rods	33, 42	155		
Controls (hydraulic)				
automatic transmission	50			
Converter, torque	50			
Cooling system, engine	36, 45	157		
Corvette specifications	56-58			
Cowl dimensions		133		
Crankshaft	32, 41	154		
Cut-out relay	36, 45	159		
Current regulator	36, 45	159		
Cylinder case and head	32, 41	154		
Differential	27	138-139		
Dimmer switch	52	167		
Direction signal	52			
Distributor	37, 46	160		
Dome light	52	167		
Driver compartment dimensions		133		
Drive system	28	143-145		
Electrical system, engine	36-37, 45-46	159-160		
Engine	29-37, 38-46	149-153		
Engine basic design data	29, 38	147-148		
Engine, power plant mounting	29, 38	160		
Engine performance		149-153		
Exhaust system	35, 44	158		
Exterior dimensions	11	64-133		
Fan, engine	36, 45	157		
Filler, crankcase oil	35, 44	158		
Filter, oil	35, 44	158		
Finishers, exterior		134		
Firing order	37, 46	160		
10-29-54				
Flywheel		47		161
Frame, chassis		24		135
Front suspension		24-25		137
Fuel pump		35, 44		158
Fuel and vacuum pump		35, 44		158
Fuel system		35, 44		157-158
Fuses, lighting				167
Gear reduction, rear axle		27		138-139
Gear reduction, total		27		138-139
Gear reduction, transmission		48-50		162
Gearshift		48		162
Generator		36, 45		159
Glass, body		23		
Governor, engine				147
Grille, radiator				134
Gross vehicle weight				166
Guards, propeller shafts				143
Guides, valve stem		34, 43		156
Harmonic balancer		32, 41		154
Headlights		52		167
Height, vehicle overall		11		64-130
Hood				134
Horns		52		167
Horsepower		29-31, 38-41		147-153
Hoses, radiator		36, 45		157
I-beam, front axle				136
Identification, model		8		62
Ignition system		37, 46		159
Instrument panel and instruments		54-55		168
Interior dimensions		12-77		64-133
Interior upholstery		22-23		
King pin				130
Length, vehicle overall		11		64-130
License lights		52		167
Lifters, valve, hydraulic		34, 43		
Lights		52		167
Load capacity chart				160
Lock ignition		37, 46		159
Lubricant, engine		35, 44		158
Lubricant, rear axle		27		138-139
Lubricant, steering gear		51		
Lubricant, transmission		48-50		162
Lubrication system, engine		35, 44		158
Luggage compartment capacity		12-17		
Main cylinder, brake		28		146
Model identification		8		62
Mounting, Power plant engine		29, 38		160
Muffler		35, 44		158
Octane selector		35		158
Oil pump		35, 44		158
Options, regular production		54		65-131
				169-170
Pan, oil		35, 44		158
Parking brake		28		146
Parking lights		52		167
Performance, car		29, 38		
Performance, curves		30-31, 39-40		149-153
Performance, engine		30-31, 39-40		149-153

INDEX

	PASSENGER	TRUCK		PASSENGER	TRUCK
Pipe, tail and exhaust	35, 44	158	Suspension, front	24-25	137
Pistons, pins, and rings	33, 42	155	Suspension, rear	26	140-141
Piston travel	29, 38	147-148	Switches, lighting	52	167
Planetary gear unit		50			
Power take-off		162	Tail lights	52	167
Propeller shaft	28	143	Tank, fuel	35, 44	157
Propeller shaft brake		146	Tank, vacuum power reserve		146
Pump, fuel	35, 44	158	Tappets	34, 43	156
Pump, fuel and vacuum	35, 44	158	Thermostat, coolant	36, 45	157
Pump, oil	35, 44	158	Thermostat, manifold		
Pump, water	36, 45	158	heat control	35, 44	157
			Timing engine	37, 46	160
Radiator core	36, 45	157	Timing gears	32, 41	154
Radiator grille		134	Tires	49	165
Ratios, rear axle	27	138-139	Toe-in, wheel	25	136
Rear axle and drive	27	138-139	Toe-out, on turns	25	136
Rear axle, two-speed		142	Tools	52	167
Rear suspension	26	140-141	Torque, axle shaft	27	138-139
Regular equipment	54-55		Torque converter	50	
Regular production options	54	65-131	Torque, engine	29-31, 38-40	149-153
		169-170	Transmission, automatic	50	163
Regulator, voltage and current	36, 45	159	Transmission, conventional	48	162
Ride stabilizer		137, 140	Transmission, overdrive	49	
Rings, piston	33, 42	155	Treads, chassis	11	132
Rocker arms, valve	34, 43	156	Trim, interior	18-23	
			Tubes, tire		165
Seat dimensions	12-17	133	Turning diameters	51	164
Seats, valve	34, 43	156	Two-speed rear axle		142
Serial numbers	9	63			
Shackles, front spring		137	Universal joints	28	143
Shackles, rear spring	26	140-141	Upholstery	22-23	
Shock absorbers, front	24	137			
Shock absorbers, rear	26	140-141	Valve lifters, hydraulic	34, 43	
Spare wheel mounting	12-17	65-131	Valve train	34, 43	156
Spark advance, automatic	37, 46	160	Ventilation, crankcase	35, 44	158
Spark plugs	37, 46	159	Vibration damper	32, 41	154
Speedometer gears	48-49	168	Voltage & current regulator	36, 45	159
Splines, drive system	28	144-145			
Springs, front	24	137	Water pump	36, 45	157
Springs, rear	26	140-141	Weights, gross vehicle		166
Springs, valve	34, 43	156	Weights, performance	10	
Stabilizer, ride		137, 140	Weights, power plant	29, 38	147
Standard equipment		65-131	Weights, shipping and curb	10	
Starting motor	36, 45	159	Wheels	49	165
Steering gear	51	164	Wheel alignment	25	136
Steering knuckles	25	136	Wheelbase	11	64-131
Steering linkage	51		Wheel travel	24	
Steering wheel	51	164	Width, vehicle overall	11	64-132
Stop lights	52	167	Windshield	23	133
Support bearing, prop shaft		143	Windows	11, 23	133